



Quality of Light

Cameras Lenses

Camera and Lens Catalog



With over 75 years of expertise in optical technology, we deliver cutting-edge total vision systems, featuring high-performance lenses designed with our proprietary innovations. By meeting our customers' diverse needs for enhanced product quality, we drive efficiency and convenience across industries such as factory automation, logistics, and retail. Our end-to-end solutions help optimize performance and create lasting value for our customers.



Kowa's Key Markets

FACTORY AUTOMATION

With a comprehensive lineup of high-precision lenses and ruggedized, environment-resistant cameras, we enhance the efficiency and reliability of production facilities and logistics warehouses across a wide range of industries, including semiconductors, automotive, metal processing, food, medical, plastics, ceramics, and film manufacturing.



INSPECTION

By integrating lenses, cameras, and lighting with our proprietary software, we reveal workpiece conditions that are invisible in raw images. This ensures precise and effective inspection in any environment.



ROBOT VISION

Integrating vision technology with robotics minimizes labor requirements while enhancing operational efficiency. A high-performance system utilizing 2D/3D cameras and AI-driven image processing significantly improves precision and reliability in automated tasks.



HARSH ENVIRONMENTS

Guided by our concept of "Clear View, Anytime, Anywhere," we provide ruggedized vision units engineered for harsh environments. Designed to withstand vibration, shock, impact, dust, water, and oil, these durable systems deliver reliable performance in any setting. With flexible configurations tailored to your specific needs, we ensure the optimal solution for your application.



Contents

5	Cameras	31	HC Lens Series	67	Varifocal Lens Series
7	Ruggedized GigE Vision Series	33	JC10M Lens Series	68	NF Lens Series
9	Ruggedized CoaXPress Series	35	JC5M2 Lens Series	69	VM Lens Series
11	Ruggedized Harsh Environment Resistant GigE Vision Series	37	JC5MC Lens Series	71	LF Lens Series
14	3D Cameras	39	NC1M Lens Series	72	CLS Lens Series
15	Harsh Environment Resistant Series	40	JC1M Lens	73	S-Mount Lens Series
16	Rotary Wiper Vision Unit	41	JC1MS Lens Series	75	Built To Order Products
17	Ruggedized Harsh Environment Resistant IP Cameras with Network Video Recorders (Factory Automation Monitoring)	43	JC Lens Series	76	Lens Accessories
19	Accessories for the Harsh Environment Resistant GigE Vision Series	45	NCL Lens Series	78	Field of View
22	4ch CXP to GigE Multiplexer	47	Radiation Resistant Lens Series	86	Diagram of M.O.D. / Magnification Using a Close Up Ring
23	Camera Accessories	49	HC-V Lens Series	87	Field of View for Rotary Wiper Vision Unit
25	Lenses	51	JC5MC-WP Lens Series	88	Custom Design
27	XC Lens Series	53	JCM-V Lens Series	89	Comparison Table for Cameras and Lenses
29	FC24M Lens Series	55	NCM-WP/ JCM-WP Lens Series	91	Fundamentals of Cameras and Lenses
		57	EC-IR Lens Series		
		59	HC-VIS-SW Lens Series		
		61	HC-SW Lens Series		
		63	JC5M-IR Lens Series		
		65	TC Lens Series		



Camera Lineup Chart

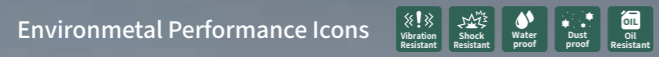
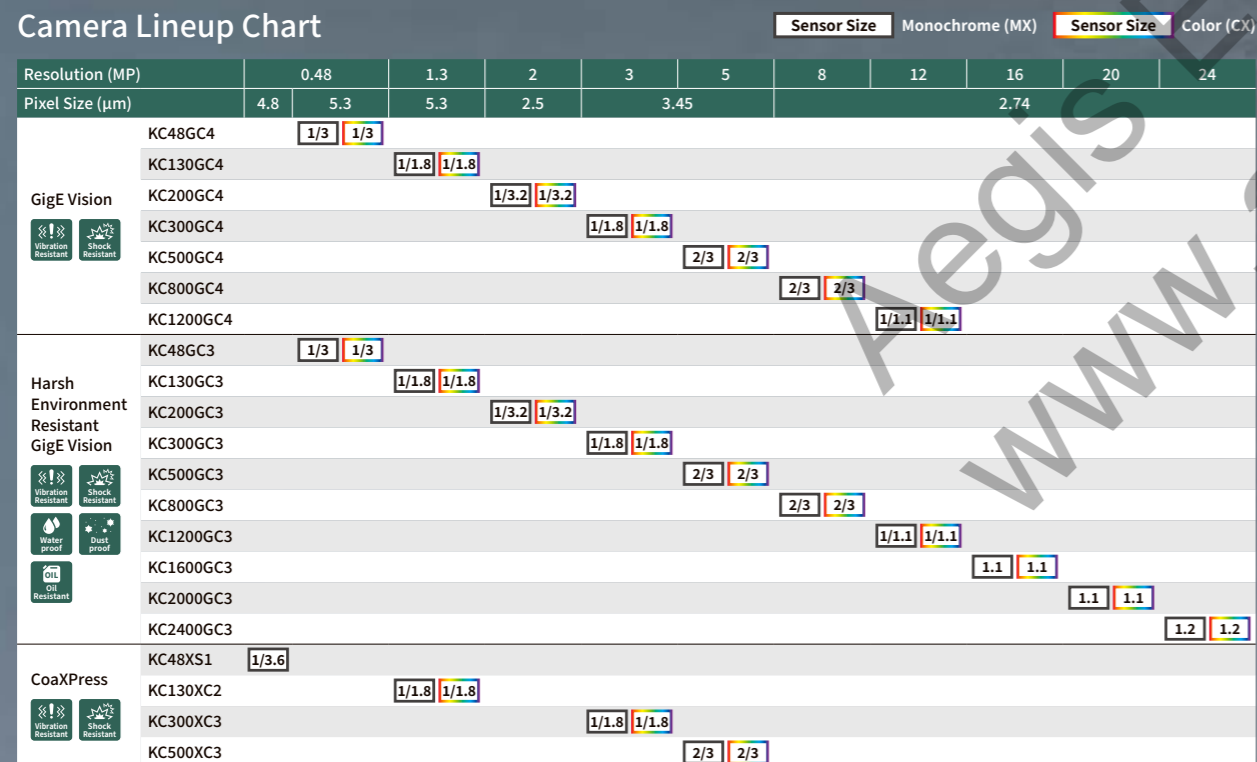

Lens Lineup Chart

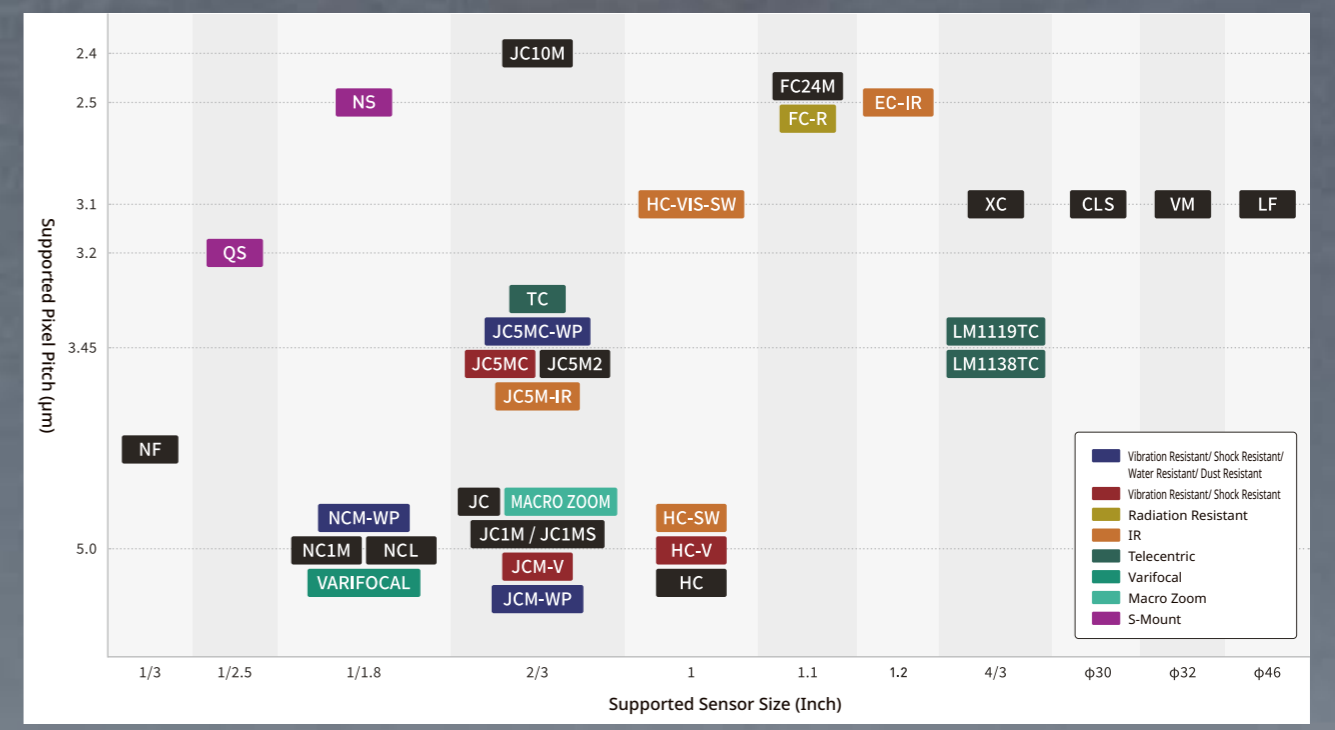



Cameras

Our camera lineup supports GigE and CoaXPress interfaces, featuring a ruggedized design for seamless performance in harsh environments. Built to withstand extreme conditions, these durable cameras ensure reliable operation in the most demanding industrial applications.

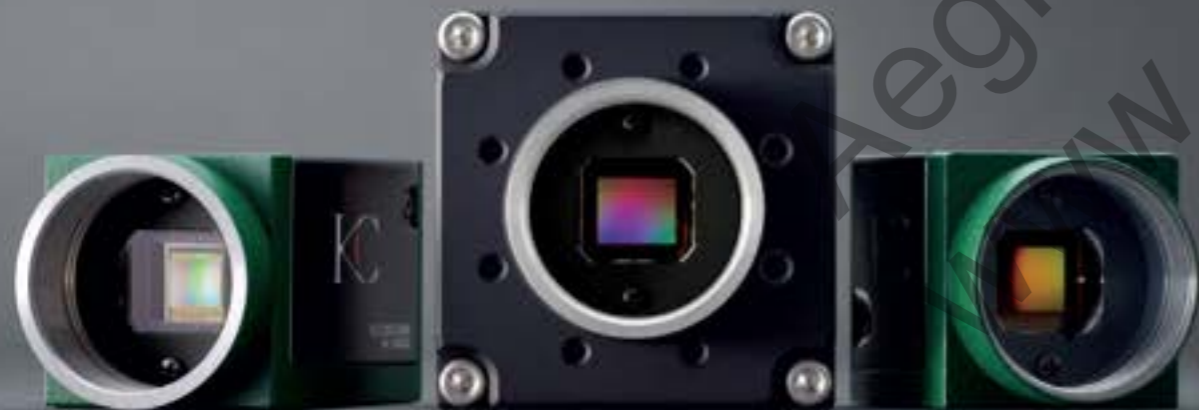

Ruggedized GigE Vision Series

- Product lineup ranging from 0.48MP to 12MP.
- Robust design with vibration and shock resistance for all models.
- Available as a complete unit with a bundled warranty, complemented by a selection of high-quality lenses.
- Comprehensive development, manufacturing, sales, and technical support by Kowa.



3MP Camera



5MP Camera



Model	GigE Vision 3MP Camera		GigE Vision 5MP Camera	
	KC300GC4MX	KC300GC4CX	KC500GC4MX	KC500GC4CX
Monochrome/Color	Monochrome	Color	Monochrome	Color
Interface	GigE Vision (RJ45)		GigE Vision (RJ45)	
Sensor	SONY IMX265		SONY IMX264	
Sensor Format	1/1.8"		2/3"	
Resolution	3MP 2064 (H) × 1544 (V)		5MP 2448 (H) × 2048 (V)	
Pixel Size	3.45μm (H) × 3.45μm (V)		3.45μm (H) × 3.45μm (V)	
Shutter	Global Shutter		Global Shutter	
Frame Rate	36fps		23fps	
Power Supply	PoE or DC24V		PoE or DC24V	
Power Requirements	4.5W or Less		4.5W or Less	
Housing Size	29 (W) × 29 (H) × 42.9 (D) mm (Excluding Projections)		29 (W) × 29 (H) × 42.9 (D) mm (Excluding Projections)	
Weight	Approx. 70g		Approx. 70g	
Lens Mount	C-mount		C-mount	
Operating Temperature/Humidity	0°C~+45°C ¹ /20%~80%RH (No Condensation)		0°C~+45°C ¹ /20%~80%RH (No Condensation)	
Storage Temperature/Humidity	-30°C~+60°C/20%~90%RH (No Condensation)		-30°C~+60°C/20%~90%RH (No Condensation)	
IP Rating	-		-	
Vibration Resistance ²	10G		10G	
Shock Resistance ³	75G		75G	
Recommended Lens Series	JC5M2 / JC1MS / JCM-WP / JCM-V / JC1M / NC1M / JC5MC / JC5MC-WP		JC5MC / JC5MC-WP / JC5M2	

0.48MP Camera



1.3MP Camera



2MP Camera



8MP Camera



12MP Camera



Model	GigE Vision 0.48MP Camera		GigE Vision 1.3MP Camera		GigE Vision 2MP Camera	
	KC48GC4MX	KC48GC4CX	KC130GC4MX	KC130GC4CX	KC200GC4MX	KC200GC4CX
Monochrome/Color	Monochrome	Color	Monochrome	Color	Monochrome	Color
Interface	GigE Vision (RJ45)		GigE Vision (RJ45)		GigE Vision (RJ45)	
Sensor	-		e2v EV76C560		Teledyne e2v Topaz 2M	
Sensor Format	1/3"		1/1.8"		1/3.2"	
Resolution	0.48MP 800 (H) × 600 (V)		1.3MP 1280 (H) × 1024 (V)		2MP 1920 (H) × 1080 (V)	
Pixel Size	5.3μm (H) × 5.3μm (V)		5.3μm (H) × 5.3μm (V)		2.5μm (H) × 2.5μm (V)	
Shutter	Global Shutter		Global Shutter		Global Shutter	
Frame Rate	101fps		60fps		56fps	
Power Supply	PoE or DC24V		PoE or DC24V		PoE or DC24V	
Power Requirements	4.5W or Less		4.5W or Less		4.5W or Less	
Housing Size	29 (W) × 29 (H) × 42.9 (D) mm (Excluding Projections)		29 (W) × 29 (H) × 42.9 (D) mm (Excluding Projections)		29 (W) × 29 (H) × 42.9 (D) mm (Excluding Projections)	
Weight	Approx. 70g		Approx. 70g		Approx. 70g	
Lens Mount	C-mount		C-mount		C-mount	
Operating Temperature/Humidity	0°C~+45°C ¹ /20%~80%RH (No Condensation)		0°C~+45°C ¹ /20%~80%RH (No Condensation)		0°C~+45°C ¹ /20%~80%RH (No Condensation)	
Storage Temperature/Humidity	-30°C~+60°C/20%~90%RH (No Condensation)		-30°C~+60°C/20%~90%RH (No Condensation)		-30°C~+60°C/20%~90%RH (No Condensation)	
IP Rating	-		-		-	
Vibration Resistance ²	10G		10G		10G	
Shock Resistance ³	75G		75G		75G	
Recommended Lens Series	JC1MS / JCM-WP / JCM-V / JC1M		JC1MS / JCM-WP / JCM-V / JC1M / NC1M		JC1MS / JCM-WP / JCM-V / NC1M	

Model	GigE Vision 8MP Camera		GigE Vision 12MP Camera	
	KC800GC4MX	KC800GC4CX	KC1200GC4MX	KC1200GC4CX
Monochrome/Color	Monochrome	Color	Monochrome	Color
Interface	GigE Vision (RJ45)		GigE Vision (RJ45)	
Sensor	SONY IMX546		SONY IMX545	
Sensor Format	2/3"		1/1.1"	
Resolution	8MP 2856 (H) × 2848 (V)		12MP 4080 (H) × 3008 (V)	
Pixel Size	2.74μm (H) × 2.74μm (V)		2.74μm (H) × 2.74μm (V)	
Shutter	Global Shutter		Global Shutter	
Frame Rate	13fps		8fps	
Power Supply	PoE or DC24V		PoE or DC24V	
Power Requirements	6W or Less		6W or Less	
Housing Size	29 (W) × 29 (H) × 42.9 (D) mm (Excluding Projections)		29 (W) × 29 (H) × 42.9 (D) mm (Excluding Projections)	
Weight	Approx. 70g		Approx. 70g	
Lens Mount	C-mount		C-mount	
Operating Temperature/Humidity	0°C~+45°C ¹ /20%~80%RH (No Condensation)		0°C~+45°C ¹ /20%~80%RH (No Condensation)	
Storage Temperature/Humidity	-30°C~+60°C/20%~90%RH (No Condensation)		-30°C~+60°C/20%~90%RH (No Condensation)	
IP Rating	-		-	
Vibration Resistance ²	10G		10G	
Shock Resistance ³	75G		75G	
Recommended Lens Series	JC10M		FC24M / EC-IR / XC	

* The combination with the lens is just an example. Please inquire about the lens specifications or check the lens page separately for details.

1. Appropriate heat dissipation is required. Please contact us for more details. 2. Complies with IEC 60068-2-6 (JIS C 60068-2-6). 3. Complies with MIL-STD-883C.

Ruggedized CoaXPress Series

- Product lineup ranging from 0.48MP to 5MP.
- Robust design with vibration and shock resistance for all models.
- Ultra compact and lightweight design.
- High speed data transfer via a single coaxial cable.
- Available as a complete unit with a bundled warranty, complemented by a selection of high-quality lenses.
- Comprehensive development, manufacturing, sales, and technical support by Kowa.



0.48MP Camera



CoaXPress 0.48MP Camera	
Model	KC48XS1MX
Monochrome/Color	Monochrome
Interface	CXP-2 (Micro BNC)
Sensor	onsemi PYTHON480
Sensor Format	1/3.6"
Resolution	0.48MP 800 (H) × 600 (V)
Pixel Size	4.8µm (H) × 4.8µm (V)
Shutter	Global Shutter
Frame Rate	100fps
Power Supply	PoCXP
Power Requirements	2W or Less
Housing Size	29 (W) × 19 (H) × 33 (D) mm (Excluding Projections)
Weight	Approx. 30g
Lens Mount	S-mount
Operating Temperature/Humidity	0°C~+45°C ¹⁾ /20%~80%RH (No Condensation)
Storage Temperature/Humidity	-30°C~+60°C/20%~90%RH (No Condensation)
IP Rating	-
Vibration Resistance ³⁾	10G
Shock Resistance ⁴⁾	75G
Recommended Lens Series	QS / NS

1.3MP Camera



CoaXPress 1.3MP Camera		
Model	KC130XC2MX	KC130XC2CX
Monochrome/Color	Monochrome	Color
Interface	CXP-2 (BNC)	
Sensor	e2v EV76C560	
Sensor Format	1/1.8"	
Resolution	1.3MP 1280 (H) × 1024 (V)	
Pixel Size	5.3µm (H) × 5.3µm (V)	
Shutter	Global Shutter	
Frame Rate	60fps	
Power Supply	PoCXP	
Power Requirements	1.5W or Less	
Housing Size	29 (W) × 29 (H) × 37 (D) mm (Excluding Projections)	
Weight	Approx. 50g	
Lens Mount	C-mount	
Operating Temperature/Humidity	0°C~+45°C ¹⁾ /20%~80%RH (No Condensation)	
Storage Temperature/Humidity	-30°C~+60°C/20%~90%RH (No Condensation)	
IP Rating	-	
Vibration Resistance ³⁾	10G	
Shock Resistance ⁴⁾	75G	
Recommended Lens Series	JC1MS / JCM-WP / JCM-V / JC1M / NC1M	

3MP Camera



CoaXPress 3MP Camera		
Model	KC300XC3MX	KC300XC3CX
Monochrome/Color	Monochrome	Color
Interface	CXP-6 (BNC)	
Sensor	SONY IMX252	
Sensor Format	1/1.8"	
Resolution	3MP 2064 (H) × 1544 (V)	
Pixel Size	3.45µm (H) × 3.45µm (V)	
Shutter	Global Shutter	
Frame Rate	149fps	
Power Supply	PoCXP	
Power Requirements	3.6W or Less	
Housing Size	29 (W) × 29 (H) × 37 (D) mm (Excluding Projections)	
Weight	Approx. 50g	
Lens Mount	C-mount	
Operating Temperature/Humidity	0°C~+35°C ²⁾ /20%~80%RH (No Condensation)	
Storage Temperature/Humidity	-30°C~+60°C/20%~90%RH (No Condensation)	
IP Rating	-	
Vibration Resistance ³⁾	10G	
Shock Resistance ⁴⁾	75G	
Recommended Lens Series	JC5M2 / JC1MS / JCM-WP / JCM-V / JC1M / NC1M / JC5MC / JC5MC-WP	

5MP Camera



CoaXPress 5MP Camera		
Model	KC500XC3MX	KC500XC3CX
Monochrome/Color	Monochrome	Color
Interface	CXP-6 (BNC)	
Sensor	SONY IMX250	
Sensor Format	2/3"	
Resolution	5MP 2464 (H) × 2056 (V)	
Pixel Size	3.45µm (H) × 3.45µm (V)	
Shutter	Global Shutter	
Frame Rate	95fps	
Power Supply	PoCXP	
Power Requirements	3.6W or Less	
Housing Size	29 (W) × 29 (H) × 37 (D) mm (Excluding Projections)	
Weight	Approx. 50g	
Lens Mount	C-mount	
Operating Temperature/Humidity	0°C~+35°C ²⁾ /20%~80%RH (No Condensation)	
Storage Temperature/Humidity	-30°C~+60°C/20%~90%RH (No Condensation)	
IP Rating	-	
Vibration Resistance ³⁾	10G	
Shock Resistance ⁴⁾	75G	
Recommended Lens Series	JC5MC / JC5MC-WP / JC5M2	

*The combination with the lens is just an example. Please inquire about the lens specifications or check the lens page separately for details.
 1: Appropriate heat dissipation is required. Please contact us for more details. 2: Please use in an environment where the rooming surface temperature is 55°C or less. 3: Complies with IEC 60068-2-6 / JIS C 60068-2-6. 4: Complies with MIL-STD-810H.

Ruggedized Harsh Environment Resistant GigE Vision Series

- Product lineup ranging from 0.48MP to 24MP.
- Ruggedized design featuring vibration and impact resistance, along with dustproof, waterproof, and oil resistance protection.
- Available as a complete unit with a bundled warranty, complemented by a selection of high-quality lenses.
- Comprehensive development, manufacturing, sales, and technical support by Kowa.



0.48MP Camera

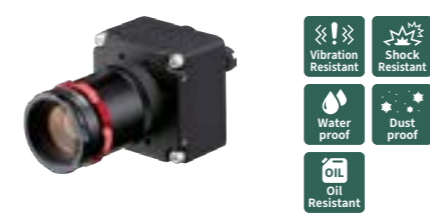

1.3MP Camera

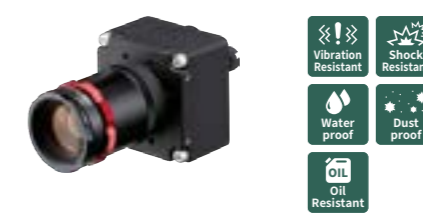

2MP Camera



	Harsh Environment Resistant GigE Vision 0.48MP Camera		Harsh Environment Resistant GigE Vision 1.3MP Camera		Harsh Environment Resistant GigE Vision 2MP Camera	
Model	KC48GC3MX	KC48GC3CX	KC130GC3MX	KC130GC3CX	KC200GC3MX	KC200GC3CX
Monochrome/Color	Monochrome	Color	Monochrome	Color	Monochrome	Color
Interface	GigE Vision (M12 X-code)		GigE Vision (M12 X-code)		GigE Vision (M12 X-code)	
Sensor			e2v EV76C560		Teledyne e2v Topaz 2M	
Sensor Format	1/3"		1/1.8"		1/3.2"	
Resolution	0.48MP 800 (H) × 600 (V)		1.3MP 1280 (H) × 1024 (V)		2MP 1920 (H) × 1080 (V)	
Pixel Size	5.3µm (H) × 5.3µm (V)		5.3µm (H) × 5.3µm (V)		2.5µm (H) × 2.5µm (V)	
Shutter	Global Shutter		Global Shutter		Global Shutter	
Frame Rate	101fps		60fps		56fps	
Power Supply	PoE or DC24V		PoE or DC24V		PoE or DC24V	
Power Requirements	4.5W or Less		4.5W or Less		4.5W or Less	
Housing Size	45 (W) × 45 (H) × 30 (D) mm (Excluding Projections)		45 (W) × 45 (H) × 30 (D) mm (Excluding Projections)		45 (W) × 45 (H) × 30 (D) mm (Excluding Projections)	
Weight	Approx. 120g		Approx. 120g		Approx. 120g	
Lens Mount	C-mount		C-mount		C-mount	
Operating Temperature/Humidity	0°C~+45°C ¹ /20%~80%RH (No Condensation)		0°C~+45°C ¹ /20%~80%RH (No Condensation)		0°C~+45°C ¹ /20%~80%RH (No Condensation)	
Storage Temperature/Humidity	-30°C~+60°C/20%~90%RH (No Condensation)		-30°C~+60°C/20%~90%RH (No Condensation)		-30°C~+60°C/20%~90%RH (No Condensation)	
IP Rating	IP67 Rated (IP69K combined with KC-TC1 or KC-TC2)		IP67 Rated (IP69K combined with KC-TC1 or KC-TC2)		IP67 Rated (IP69K combined with KC-TC1 or KC-TC2)	
Vibration Resistance ²	10G		10G		10G	
Shock Resistance ³	75G		75G		75G	
Oil Resistance ⁴	○		○		○	
Recommended Lens Series	JC1MS / JCM-WP / JCM-V / JC1M		JC1MS / JCM-WP / JCM-V / JC1M / NC1M		JC1MS / JCM-WP / JCM-V / NC1M	

3MP Camera



5MP Camera



8MP Camera



	Harsh Environment Resistant GigE Vision 3MP Camera		Harsh Environment Resistant GigE Vision 5MP Camera		Harsh Environment Resistant GigE Vision 8MP Camera	
Model	KC300GC3MX	KC300GC3CX	KC500GC3MX	KC500GC3CX	KC800GC3MX	KC800GC3CX
Monochrome/Color	Monochrome	Color	Monochrome	Color	Monochrome	Color
Interface	GigE Vision (M12 X-code)		GigE Vision (M12 X-code)		GigE Vision (M12 X-code)	
Sensor	SONY IMX265		SONY IMX264		SONY IMX546	
Sensor Format	1/1.8"		2/3"		2/3"	
Resolution	3MP 2064 (H) × 1544 (V)		5MP 2448 (H) × 2048 (V)		8MP 2856 (H) × 2848 (V)	
Pixel Size	3.45µm (H) × 3.45µm (V)		3.45µm (H) × 3.45µm (V)		2.74µm (H) × 2.74µm (V)	
Shutter	Global Shutter		Global Shutter		Global Shutter	
Frame Rate	36fps		23fps		13fps	
Power Supply	PoE or DC24V		PoE or DC24V		PoE or DC24V	
Power Requirements	4.5W or Less		4.5W or Less		6W or Less	
Housing Size	45 (W) × 45 (H) × 30 (D) mm (Excluding Projections)		45 (W) × 45 (H) × 30 (D) mm (Excluding Projections)		45 (W) × 45 (H) × 38 (D) mm (Excluding Projections)	
Weight	Approx. 120g		Approx. 120g		Approx. 140g	
Lens Mount	C-mount		C-mount		C-mount	
Operating Temperature/Humidity	0°C~+45°C ¹ /20%~80%RH (No Condensation)		0°C~+45°C ¹ /20%~80%RH (No Condensation)		0°C~+45°C ¹ /20%~80%RH (No Condensation)	
Storage Temperature/Humidity	-30°C~+60°C/20%~90%RH (No Condensation)		-30°C~+60°C/20%~90%RH (No Condensation)		-30°C~+60°C/20%~90%RH (No Condensation)	
IP Rating	IP67 Rated (IP69K combined with KC-TC1 or KC-TC2)		IP67 Rated (IP69K combined with KC-TC1 or KC-TC2)		IP67 Rated (IP69K combined with KC-TC1 or KC-TC2)	
Vibration Resistance ²	10G		10G		10G	
Shock Resistance ³	75G		75G		75G	
Oil Resistance ⁴	○		○		○	
Recommended Lens Series	JC5M2 / JC1MS / JCM-WP / JCM-V / JC1M / NC1M / JC5M / JC5MC-WP		JC5MC / JC5MC-WP / JC5M2		JC10M	



Vibration & Shock Resistant

Optimized for high-performance operation in environments subject to vibration and impact, such as manufacturing facilities and robot-assisted distribution warehouses.



Dustproof

Suitable for outdoor applications, drone operations, construction-related environments, and more.



Waterproof

Can be used in a wide range of situations, including food processing plants, clothing factories, and other moisture-prone settings.



Oil Resistant

Designed for manufacturing environments where exposure to oil mist and cutting oil is prevalent.

* The combination with the lens is just an example. Please inquire about the lens specifications or check the lens page separately for details.
 The product specifications and external appearance may be changed for improvement without prior notice. *1: Appropriate heat dissipation is required. Please contact us for more details. *2: Complies with IEC 60068-2-60/IEC 60068-2-61. *3: Complies with MIL-STD-883C. *4: Complies to our company standards.

12MP Camera



16MP Camera



	Harsh Environment Resistant GigE Vision 12MP Camera		Harsh Environment Resistant GigE Vision 16MP Camera	
Model	KC1200GC3MX	KC1200GC3CX	KC1600GC3MX	KC1600GC3CX
Monochrome/Color	Monochrome	Color	Monochrome	Color
Interface	GigE Vision (M12 X-code)		GigE Vision (M12 X-code)	
Sensor	SONY IMX545		SONY IMX542	
Sensor Format	1/1.1"		1.1"	
Resolution	12MP 4128 (H) × 3008 (V)		16MP 5328 (H) × 3040 (V)	
Pixel Size	2.74μm (H) × 2.74μm (V)		2.74μm (H) × 2.74μm (V)	
Shutter	Global Shutter		Global Shutter	
Frame Rate	8fps		6fps	
Power Supply	PoE or DC24V		PoE or DC24V	
Power Requirements	6W or Less		6W or Less	
Housing Size	45 (W) × 45 (H) × 38 (D) mm (Excluding Projections)		45 (W) × 45 (H) × 38 (D) mm (Excluding Projections)	
Weight	Approx. 140g		Approx. 140g	
Lens Mount	C-mount		C-mount	
Operating Temperature/Humidity	0°C~+45°C ¹ /20%~80%RH (No Condensation)		0°C~+45°C ¹ /20%~80%RH (No Condensation)	
Storage Temperature/Humidity	-30°C~+60°C/20%~90%RH (No Condensation)		-30°C~+60°C/20%~90%RH (No Condensation)	
IP Rating	IP67 Rated (IP69K combined with KC-TC1 or KC-TC2)		IP67 Rated (IP69K combined with KC-TC1 or KC-TC2)	
Vibration Resistance ²	10G		10G	
Shock Resistance ³	75G		75G	
Oil Resistance ⁴	○		○	
Recommended Lens Series	FC24M / EC-IR / XC		FC24M / EC-IR / XC	

20MP Camera



24MP Camera



	Harsh Environment Resistant GigE Vision 20MP Camera		Harsh Environment Resistant GigE Vision 24MP Camera	
Model	KC2000GC3MX	KC2000GC3CX	KC2400GC3MX	KC2400GC3CX
Monochrome/Color	Monochrome	Color	Monochrome	Color
Interface	GigE Vision (M12 X-code)		GigE Vision (M12 X-code)	
Sensor	SONY IMX541		SONY IMX540	
Sensor Format	1.1"		1.2"	
Resolution	20MP 4512 (H) × 4512 (V)		24MP 5328 (H) × 4608 (V)	
Pixel Size	2.74μm (H) × 2.74μm (V)		2.74μm (H) × 2.74μm (V)	
Shutter	Global Shutter		Global Shutter	
Frame Rate	5fps		4fps	
Power Supply	PoE or DC24V		PoE or DC24V	
Power Requirements	6W or Less		6W or Less	
Housing Size	45 (W) × 45 (H) × 38 (D) mm (Excluding Projections)		45 (W) × 45 (H) × 38 (D) mm (Excluding Projections)	
Weight	Approx. 140g		Approx. 140g	
Lens Mount	C-mount		C-mount	
Operating Temperature/Humidity	0°C~+45°C ¹ /20%~80%RH (No Condensation)		0°C~+45°C ¹ /20%~80%RH (No Condensation)	
Storage Temperature/Humidity	-30°C~+60°C/20%~90%RH (No Condensation)		-30°C~+60°C/20%~90%RH (No Condensation)	
IP Rating	IP67 Rated (IP69K combined with KC-TC1 or KC-TC2)		IP67 Rated (IP69K combined with KC-TC1 or KC-TC2)	
Vibration Resistance ²	10G		10G	
Shock Resistance ³	75G		75G	
Oil Resistance ⁴	○		○	
Recommended Lens Series	FC24M / EC-IR / XC		FC24M / EC-IR / XC	

3D Cameras



- Global shutter compatible with high-speed transport.
- 3D camera featuring vibration and shock resistance, dustproof and waterproof capabilities.
- Lineup capable of handling inspection and measurement across various distances close, medium, and long range.
- Achieves reduced staffing and automation when combined with robots.



Type	Short Distance Type	Middle Distance Type	Long Distance Type	Long Distance and Wide Angle Type
Model	KC130GP103	KC130GP109	KC130GP125	KC130GP120
Monochrome/Color	Monochrome			
Interface	GigE Vision			
Output Image Size	1248×933 pixel			
Depth Range	300 mm / 400 mm	600 mm / 1500 mm	2000 mm / 3500 mm	1500 mm / 3500 mm
Field of View Size *1 (Horizontal x Vertical)	101×112 mm / 154×154 mm	222×240 mm / 702×624 mm	970×837 mm / 1771×1477 mm	1202×960 mm / 2961×2279 mm
Measurement time	50 ms or Less			
Power Supply	PoE			
Power Requirements	12.95 W			
Housing Size	142 (W) × 62.5 (H) × 121 (D) mm (Excluding Projections)			
Weight	Approx. 1.2kg			
Operating Temperature/Humidity	0°C ~ +45°C / 20% ~ 80%RH (No condensation)			
Storage Temperature/Humidity	-30°C ~ +60°C / 20% ~ 90%RH (No condensation)			
IP Rating	IP67 Equivalent			
Vibration Resistance*2	10 G			
Shock Resistance*3	75 G			

Imaging Range

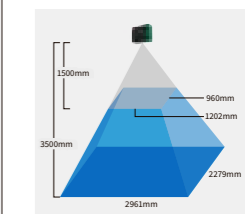
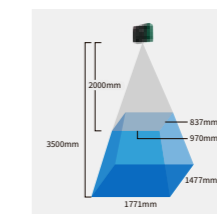
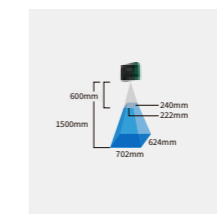
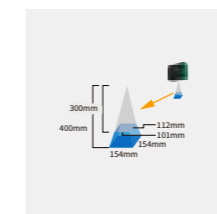

* The combination with the lens is just an example. Please inquire about the lens specifications or check the lens page separately for details.

* The product specifications and external appearance may be changed for improvement without prior notice. *2: Appropriate heat dissipation is required. Please contact us for more details. *3: Complies with IEC 60068-2-6 (MIL-STD-883C). *4: Complies with MIL-STD-883C.

* The product specifications and external appearance may be changed for improvement without prior notice. *1: Theoretical value. *2: Complies with IEC 60068-2-6 (MIL-STD-883C). *3: Complies with MIL-STD-883C.

Harsh Environment Resistant Series



Harsh Environment Resistant vision unit lineup



Rotary Wiper Vision Unit



Model	KC-RW1S
Size	50mm x 50mm x 31mm (excluding protrusions such as nozzles and one-touch joints)
Power	Compressed air (φ6 urethane hose joint)
Set pressure	0.05~0.1MPa
Air consumption	15~20ℓ/min
Supply air purity class	ISO8573-1:2010 [2:3:2]
IP Class ^{*1}	IPX7 (air supply, when rotating the swivel unit)
Operating temperature	+10°C~+45°C
Storage temperature	-20°C~+60°C
Camera resolution ^{*2}	0.48MP, 1.3MP, 2MP, 3MP (P.12), Full HD IP Camera (P.18)
Lens focal length ^{*3}	f=2.7mm, 8mm, 12mm, 16mm, 25mm

*1: Not dustproof. *2: Please refer to the camera page for details on camera specifications. *3: Some lenses may not be compatible with certain cameras. Please refer to the field of view table at the end of the catalog for more information.

Achieves clear visibility even in harsh environments where water and oil are present. Suitable for applications such as monitoring machine processes inside industrial machinery where there are numerous blind spots. When used in combination with Kowa vision processors, it enables AI-driven analysis of cutting chip accumulation and can send alert notifications in case of machining defects.

Maintains a "clear view" even within machining equipment.

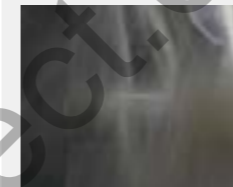

Without rotation mechanism.

With rotation mechanism.

Effectively captures the interior of machining equipment, such as lathes, milling machines, and grinding machines, without attracting coolant or cutting chips.



Water and Oil-Repellent Coatings



Constructed with scratch-resistant sapphire glass featuring durable water and oil-repellent coatings for enhanced protection and clarity.

Air Supply



The front glass rotates at high speed, driven by high-pressure air supply, effectively preventing liquids from penetrating the interior.

High Speed Rotation



High-speed rotation effectively removes water and oil deposits, ensuring a clear and unobstructed view.



Focal length options include 2.7mm, 8mm, 12mm, 16mm, and 25mm to suit various applications.



Resolution options for GigE cameras include 0.48MP, 1.3MP, 2MP, and 3MP. For Kowa's IP cameras, 2MP resolution is available.

Angle of View Table		LM3NF f=2.7mm	LM8RW f=8mm	LM12RW f=12mm	LM16RW f=16mm	LM25RW f=25mm
Harsh Environment Resistant GigE Vision Camera	0.48MP GigE camera •KC48GC3MX •KC48GC3CX	89°×66°	29°×22°	20°×15°	15°×11°	9°×7°
	1.3MP GigE camera •KC130GC3MX •KC130GC3CX	—	45°×37°	31°×25°	23°×19°	15°×12°
	2MP GigE camera •KC200GC3MX •KC200GC3CX	100°×56°	33°×19°	22°×12°	17°×9°	10°×6°
	3MP GigE camera •KC300GC3MX •KC300GC3CX	—	47°×36°	33°×25°	25°×18°	16°×12°
Harsh Environment Resistant IP Camera	2MP IP Camera •KC200NB1CX	116°×65°	38°×22°	26°×14°	19°×11°	12°×7°

Field of view table P.87

Ruggedized Harsh Environment Resistant IP Cameras with Network Video Recorders (Factory Automation Monitoring)



Ruggedized Harsh Environment Resistant IP Camera



- Vibration Resistant
- Shock Resistant
- Waterproof
- Dustproof
- Oil Resistant

2MP Harsh Environment Resistant IP Camera	
Model	KC200NB1CX
Video Compression Method	H.264/H.264+/MJPEG
Sensor	1/2.8" SONY IMX307
Resolution	2MP 1920 (H) x 1080 (V)
Pixel Size	2.9µm
Shutter	Rolling Shutter
Power Supply	PoE or DC24V
Lens Mount	C-Mount (Can be converted to a CS-Mount by removing the mount adapter.)
Housing Size	45 (W) × 45 (H) × 38 (D) mm (Excluding projections)
Weight	Approx. 145g
Operating Temperature/Humidity	0°C ~ +50°C / 20% ~ 80%RH (No condensation)
Storage Temperature/Humidity	-30°C ~ +60°C / 20% ~ 90%RH (No condensation)
IP Rating	IP67 Rated (IP69K combined with KC-TC1 or KC-TC2)
Vibration Resistance ¹	10G
Shock Resistance ²	75G
Recommended Lens Series	JC1MS/JCM-WP/JCM-V/JC1M/NC1M

Network Video Recorder



Network Video Recorder for KC200NB1CX	
Model	KC-VR1N
Recording Capacity	1TB (Built-in SSD)
Video Output	HDMI Output
Video Compression Method	MJPEG, H264, H264+
Backup	USB Memory
USB Port	USB2.0*2 port
Recording Method	Continuous recording, alarm recording, event recording, and motion recording.
Camera power supply	PoE compatible (IEEE802.3af)
Alarm Input	IO Input / Output Possible [Lighting Control, DI (Trigger)]
Power Supply	DC + 48 ~ 56V (AC Adapter 100V) *Sold Separately
Housing Size	57 (W) × 195 (H) × 125 (D) mm (Excluding projections)
Weight	Approx. 1.1kg
Operating Temperature/Humidity	0°C ~ +45°C / 20% ~ 80%RH (No condensation)
Storage Temperature/Humidity	-30°C ~ +60°C / 20% ~ 90%RH (No condensation)

*This NVR does not possess environmental resistance. Please be mindful of the usage environment.

From comprehensive monitoring to detailed operation monitoring within the equipment, we have achieved "Operational Status Visualization and Improved Efficiency."

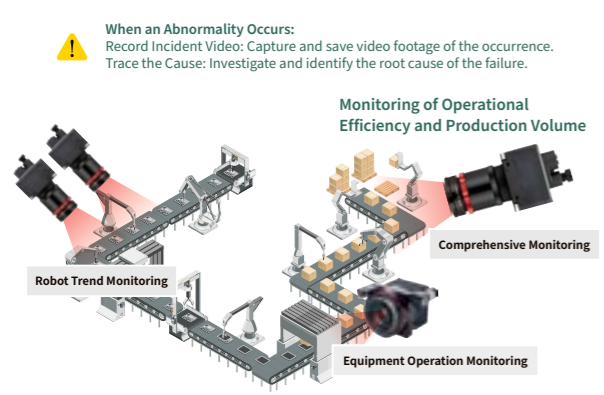

Production Line Monitoring
When combined with an NVR, up to four devices can be connected simultaneously, enabling 1TB of recording capacity. It also supports recording both before and after abnormalities occur, ensuring comprehensive event capture.

Monitoring Inside Machining Equipment
Combining Kowa's ruggedized harsh environment resistant IP camera with an NVR enables remote monitoring, continuous recording, and recording when an abnormality occurs.



When combined with a Rotary Wiper Vision Unit (KC-RW1S) and a lens tube, it is suitable for use in environments with airborne water droplets or dust.

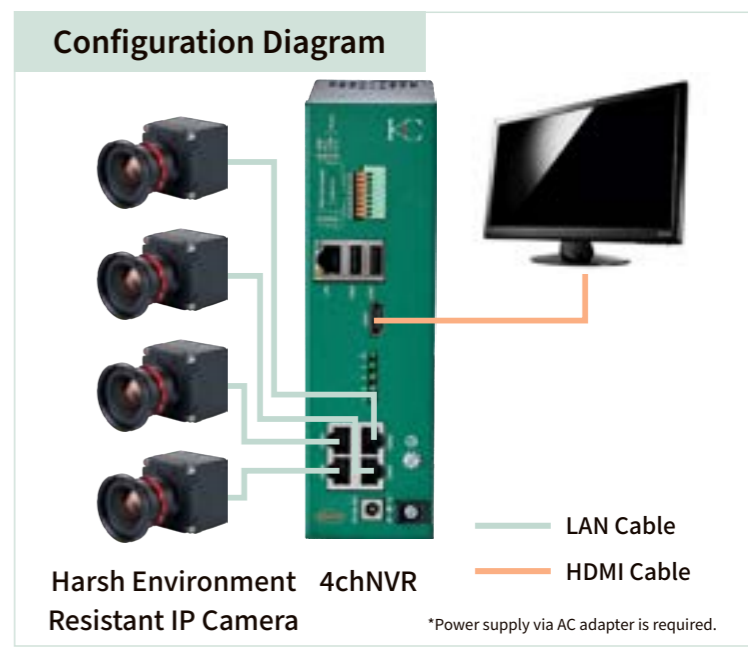

Dustproof, Waterproof, Oil-Resistant Lens Tube / Air Curtain

Two specialized covers are available to enhance the durability and functionality of Kowa lenses. When attached to non-water-resistant lenses, these covers elevate the assembly's protection to an IP69K waterproof rating. Beyond water resistance, these covers also bolster oil resistance. Additionally, they accommodate the installation of optical filters within the cover, allowing for further customization and protection.



An air curtain that can be additionally installed on the TC1 and TC2 series. Continuous air supply allows for the removal of water droplets and powder from the glass on the front of the lens cover.



TC1 Series



Categories	Model	Product Name	Size	Compatible Lens Series
Glass Parts	KC-TC1L1	Waterproof Glass Part	Φ45	
	KC-TC1L2	Waterproof and Oil-Resistant Glass Part	Φ45	
	KC-TC1L3	Waterproof Acrylic Part	Φ45	
Cover Parts	KC-TC1A	Cover Part	Φ45×40mm	JC5MC, JC5MC-WP Series (8mm to 25mm)*1
	KC-TC1B	Cover Part	Φ45×56.5mm	JC1MS Series*2 / JCM-V, JCM-WP Series (8mm to 25mm) / JC5MC Series (35mm to 50mm)
	KC-TC1C	Cover Part	Φ45×70mm	JC1MS Series*2 (35mm, 75mm) / JCM-V, JCM-WP Series (35mm) / JC10M Series*2 (12mm to 25mm)
	KC-TC1D	Cover Part	Φ45×85.5mm	JC1MS Series*2 (50mm) / JCM-V, JCM-WP Series (50mm)
Camera Part	KC-TC1M	Camera Mounting Part	Φ45	
O-ring	KC-TC1P1	Waterproof O-ring	Φ45	
	KC-TC1P2	Waterproof and Oil-Resistant O-ring	Φ45	

KC-TC1N1



Model	KC-TC1N1
Product Name	Air Curtain
Weight	Approx.90g
Operating Temperature / Humidity *1	0°C~+45°C / 20%~80%RH (No condensation)
Storage Temperature / Humidity	-20°C~+60°C / 20%~90%RH (No condensation)
Available Lens Tubes	TC1 Series

TC2 Series



Categories	Model	Product Name	Size	Compatible Lens Series
Glass Parts	KC-TC2L1	Waterproof Glass Part	Φ79	
	KC-TC2L2	Waterproof and Oil-Resistant Glass Part	Φ79	
	KC-TC2L3	Waterproof Acrylic Part	Φ79	
Cover Parts	KC-TC2A	Cover Part	Φ79×51mm	LM3NCM-WP, LM5JCM-WP
	KC-TC2B	Cover Part	Φ79×66mm	JC1MS Series (8mm to 35mm) / JC10M Series (12mm to 16mm)
	KC-TC2C	Cover Part	Φ79×72mm	JC10M Series (5mm to 8mm)
	KC-TC2D	Cover Part	Φ79×87mm	JC1MS Series (50mm, 75mm) / JC10M Series (35mm) / XC Series (35mm) / FC24M Series (8mm to 75mm)
	KC-TC2E	Cover Part	Φ79×97mm	JC1MS Series (100mm) / JC10M Series (50mm) / XC Series (12mm, 16mm, 50mm)
	KC-TC2F	Cover Part	Φ79×101mm	XC Series (25mm) / FC24M Series (100mm)
Camera Part	KC-TC2M	Camera mounting part	Φ79	
O-ring	KC-TC2P1	Waterproof O-ring	Φ79	
	KC-TC2P2	Waterproof and Oil-Resistant O-ring	Φ79	

KC-TC2N1



Model	KC-TC2N1
Product Name	Air Curtain
Weight	Approx.95g
Operating Temperature / Humidity *1	0°C~+45°C / 20%~80%RH (No condensation)
Storage Temperature / Humidity	-20°C~+60°C / 20%~90%RH (No condensation)
Available Lens Tubes	TC2 Series

* The product specifications and external appearance may be changed for improvement without prior notice. *1: When using the LM25JC5MC-WP, please apply the spacer KC-TC1S3/S4 with the KC-TC1A. For further details, please contact our support team. *2: The thumb screws attached to the lens should be replaced with set screws for proper installation. * Choose the appropriate cover part length based on the lens to be attached. * Glass and acrylic parts are available in three specifications: waterproof, waterproof & oil-resistant, and waterproof acrylic. * O-rings and packing options include waterproof and waterproof & oil-resistant specifications.

Waterproof Ring-shaped Lighting

This ruggedized harsh environment resistant lighting is built to withstand even the most demanding conditions, offering exceptional vibration and impact resistance along with reliable dustproof and waterproof performance.

Specifically engineered to support seamless integration of the ruggedized harsh environment resistant GigE Vision series and lighting into a unified configuration.

Power can be supplied directly from the camera to the lighting.

Lighting functions, including constant illumination, strobe, brightness adjustment, and flash interval, can be controlled directly from the camera.

The compact 70mm diameter design allows for use even in tight or confined spaces.

In addition to its IP67 rated waterproof and dustproof performance, the durable housing is engineered to withstand vibration and shock from industrial robots, ensuring reliable operation in demanding environments.

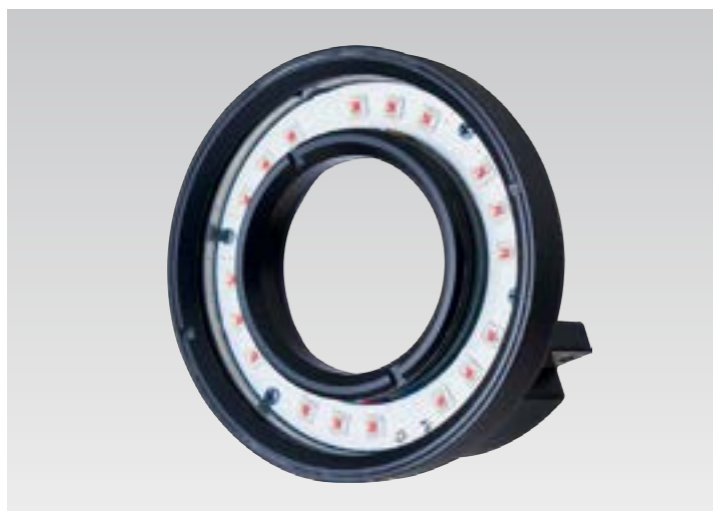

Model	KC-RL1W	KC-RL1R
Product Name	Waterproof Ring-shaped Lighting (White)	Waterproof Ring-shaped Lighting (Red)
Input Voltage	24V	
Maximum Power Consumption	7W	
Control Method	PWM Control	
Interface	M8 8pin A-code	
Operating Temperature/Humidity	0°C ~ +45°C ¹ / 35% ~ 85%RH (No condensation)	
Storage Temperature/Humidity	-20°C ~ +65°C / 20% ~ 85%RH (No condensation)	
Housing Size	Outer diameter 70mm x Depth 32mm (Excluding the cable)	
Weight	Approx. 100g	
Vibration Resistance	10G	
Shock Resistance	75G	
Dustproof and Waterproof	IP67	
Supported Camera Series	Harsh Environment Resistant GigE Vision	
Recommended Lens Series	JC5MC-WP Series JC5MC Series (8 mm, 12 mm, 16 mm, 25 mm) JCM-V, JCM-WP Series (8 mm, 12 mm, 16 mm)	

*1: Ensure proper heat dissipation from the housing. For more details, please contact Kowa. Additionally, ensure the FPGA temperature of adjacent cameras remains below 90°C.

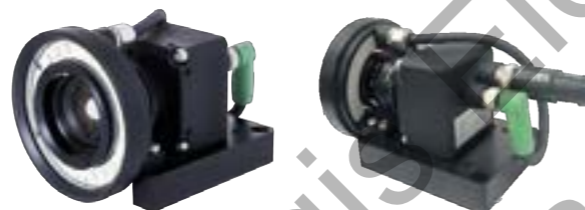

Camera Back



I/F: GigE Vision Connector: M12 (8 pins), also known as X-code, featuring waterproof and oil-resistant properties.

M8 Connector: Provides power supply from the camera, enabling power supply and control for the lighting unit.

4ch CXP to GigE Multiplexer

When KC48XS1MX CXP cameras (See page 9) are connected, their signals are converted to the GigE interface, and a maximum of four camera images can be output at once. (4 inputs/1 output)



Connection Diagram

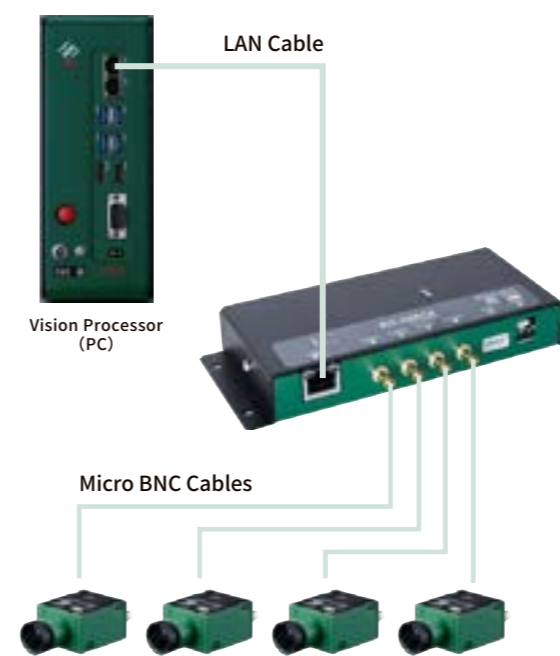

Model	KC-GM1X
Power Supply	DC24V
Input Interface	CXP (MicroBNC) × 4 supporting PoCXP
Output Interface	GigE Vision (RJ45 Connector)
Image Output Signal	1Gbps GigE Vision V2.0 Protocol (Depending on the settings, simultaneous imaging with up to four cameras is possible. In the case of simultaneous imaging with multiple cameras, the output is a single horizontal image arranged from the left in ascending order of camera channels.)
Power Requirements	58W or less (when connecting four camera units and four lighting units)
Operating Temperature/Humidity	0°C ~ +45°C / 20% ~ 80%RH (No condensation)
Storage Temperature/Humidity	-30°C ~ +60°C / 20% ~ 90%RH (No condensation)
Housing Size	161 (W) × 22.7 (H) × 64.5 (D) mm (Excluding projections)
Weight	Approx. 170g
Vibration Resistance*1	10G
Shock Resistance*2	75G
Supported Cameras	KC48XS1MX
Supported Lenses	S-Mount Series

Camera Tripod Adaptor

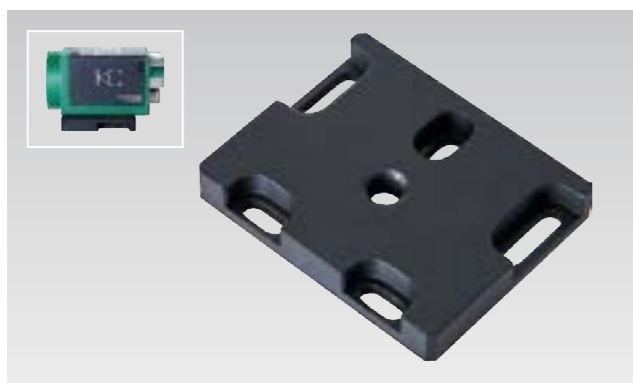

This adaptor is designed to mount a Kowa camera to a 1/4-20 UNC screw, commonly used on tripods and other mounting equipment.

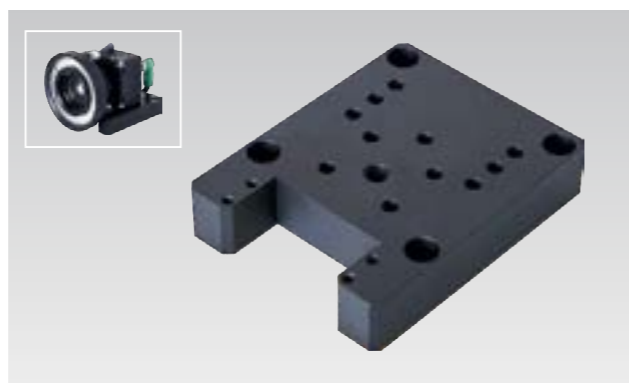

This adaptor enables seamless integration of Kowa's waterproof LED lighting with the ruggedized harsh environment resistant GigE Vision series, providing a comprehensive, unified solution. It also includes compatibility with a 1/4-20 UNC screw, allowing easy attachment to tripods or similar equipment for convenient testing and evaluation.

Model	KC-TA1	KC-TA2
Product Name	Camera Tripod Adaptor	
Size	40mm × 50mm × 6mm	76.5mm × 60mm × 15mm
Screw Dimensions	1/4-20UNC	
Supported Camera Series	GigE Vision / Harsh Environment Resistant GigE Vision / CoaXPress / Harsh Environment Resistant IP Camera	Harsh Environment Resistant GigE Vision (0.48MP, 1.3MP, 5MP, 8MP) / Harsh Environment Resistant IP Camera

PoE Injector



Model	KP-TL-POE150S
Product Name	PoE Injector
Interface	GigE Vision (RJ45)
Housing Size	81mm × 52mm × 24mm
Weight	230g
Supported Camera Series	GigE Vision / Harsh Environment Resistant GigE Vision / Harsh Environment Resistant IP Camera

Various Cables

Interface: GigE Vision

Category	Product Name	
GigE Vision Cables	RJ45-RJ45 Cable 5m	
	RJ45-RJ45 Cable 10m	
	RJ45-RJ45 Cable 20m	
	RJ45-RJ45 Cable 30m	
	RJ45-RJ45 Cable 40m	
	RJ45 to RJ45 Cable 1m with Single-end Locking Screws	
	RJ45 to RJ45 Cable 3m with Single-end Locking Screws	
	RJ45 to RJ45 Cable 5m with Single-end Locking Screws	
	RJ45 to RJ45 Cable 10m with Single-end Locking Screws	
	RJ45 to RJ45 Cable 20m with Single-end Locking Screws	
RJ45 to RJ45 Cable 30m with Single-end Locking Screws		
RJ45 to RJ45 Cable 40m with Single-end Locking Screws		

Category	Product Name	
GigE Vision Cables	RJ45 to RJ45 L-type Cable 1m with Single-end Locking Screws	
	RJ45 to RJ45 L-type Cable 3m with Single-end Locking Screws	
	RJ45 to RJ45 L-type Cable 5m with Single-end Locking Screws	
	RJ45 to RJ45 L-type Cable 10m with Single-end Locking Screws	
	RJ45 to RJ45 L-type Cable 20m with Single-end Locking Screws	
	RJ45 to RJ45 L-type Cable 30m with Single-end Locking Screws	
Harsh Environment Resistant GigE Vision Cables	M12-RJ45 Cable 1m	
	M12-RJ45 Cable 2m	
	M12-RJ45 Cable 5m	
	M12-RJ45 Cable 10m	
	M12-RJ45 Cable 15m	
	M12-RJ45 Cable 20m	
	M8-No-connector Cable 5m	
	M8-No-connector Cable 10m	

Interface: CoaXPress

Category	Product Name	
CoaXPress Cables	Micro BNC to Micro BNC Cable 1m	
	Micro BNC to Micro BNC Cable 3m	
	Micro BNC to Micro BNC Cable 4m	
	Micro BNC to Micro BNC Cable 5m	
	Micro BNC to Micro BNC Cable 5m	
	Micro BNC to Micro BNC Cable 10m	

Category	Product Name	
CoaXPress Cables	BNC-MicroBNC Cable 1m	
	BNC-MicroBNC Cable 3m	
	BNC-MicroBNC Cable 5m	
	BNC-MicroBNC Cable 10m	
	BNC-BNC Cable 1m	
	BNC-BNC Cable 2m	
	BNC-BNC Cable 3m	
	BNC-BNC Cable 5m	
	BNC-BNC Cable 10m	



Lenses

A comprehensive product lineup built on decades of proven optical expertise, offering solutions from standard lenses to specialized options designed for a wide range of applications, including ultra-wide angle, super compact, and harsh environment resistant models.



Icons

- | | | | |
|--------------------------------------|--|---------------------------------|--------------------------------|
| WBMC Wide-Band Multi-Coatings | EX-WBMC EX Wide-Band Multi-Coatings | SWIR SWIR Coatings | I R Near Infrared (NIR) |
| LO-DIS Low Distortion | FLOAT Floating Mechanism Design | X D Extra Low Dispersion | |
| RUGGED Ruggedized Lens | WATER Water Resistant | DUST Dust Resistant | |

For More Information Please Call Aegis Electronic Group, Inc. *CA- (760) 729-2026 AZ- (480) 635-8400 * aegis-g2@aegiselect.com * <http://www.aegis-elec.com>

XC Lens Series

4/3" | 20 MEGAPIXEL+ 3.1 μm

Model	Format Size (Inch)								
	4/3	1.2	1.1	1	1/1.2	2/3	1/1.8	1/2	1/3
LM8XC	●	●	●	●	●	●	●	●	●
LM12XC	●	●	●	●	●	●	●	●	●
LM16XC	●	●	●	●	●	●	●	●	●
LM25XC	●	●	●	●	●	●	●	●	●
LM35XC	●	●	●	●	●	●	●	●	●
LM50XC	●	●	●	●	●	●	●	●	●

● Compatible ◇ Suitable * Incompatible

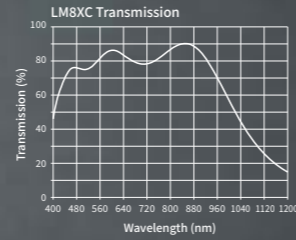

- 4/3" format size (φ23mm) and 20MP resolution.
- High-precision aspherical lenses achieve both low distortion and high-resolution, delivering exceptional optical performance.
- The wide-band multi-coatings are engineered to maximize transmission in the near-infrared range.
- An 8.5mm focal length model with a horizontal angle of 93.5° has been added to this series lineup.
- Kowa's Floating Mechanism design is incorporated into all XC series models to effectively minimize aberrations from close object distances to infinity.



LM8XC

WBMC LO-DIS FLOAT XD

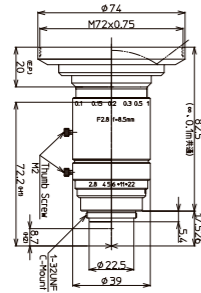

Model	LM8XC
Focal Length (mm)	8.5
Image Size (mm)	18.4×13.8 (Φ23)
Iris Range (F-Stop)	F2.8~F22
Focusing Range (m)	0.1~∞
Control	Iris: Manual Focus: Manual
Shooting Range at M.O.D. (mm)	238.4 (H) × 179.1 (V)
Angle of View (Degrees)	4/3" 93.5×77.1 1.1" 78.2×62.7 1" 72.9×57.9 2/3" 53.8×41.6
Resolution (Center, Corner)	160lp/mm, 63lp/mm
TV Distortion (%)	0.12
Back Focus in Air (mm)	12.9
Mount	C-mount
Filter Thread (mm)	M72×P0.75
Size (mm)	φ74×82.5
Weight (g)	245
Temperature Range	-10°C~+50°C

LM12XC

WBMC LO-DIS FLOAT XD

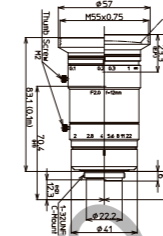

LM16XC

WBMC LO-DIS FLOAT XD

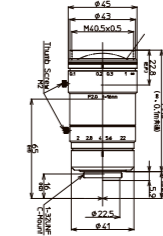

LM25XC

WBMC LO-DIS FLOAT XD

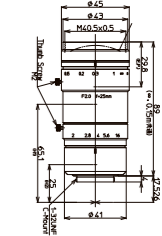

Model	LM12XC	LM16XC	LM25XC
Focal Length (mm)	12	16	25
Image Size (mm)	18.4×13.8 (Φ23)	18.4×13.8 (Φ23)	18.4×13.8 (Φ23)
Iris Range (F-Stop)	F2.0~F22	F2.0~F22	F2.0~F16
Focusing Range (m)	0.1~∞	0.1~∞	0.15~∞
Control	Iris: Manual Focus: Manual	Iris: Manual Focus: Manual	Iris: Manual Focus: Manual
Shooting Range at M.O.D. (mm)	181.5 (H) × 135.5 (V)	134.6 (H) × 100.8 (V)	124.8 (H) × 93.0 (V)
Angle of View (Degrees)	4/3" 74.9×59.6 1.1" 60.6×47.1 1" 55.9×43.1 2/3" 39.8×30.2	60.6×47.2 48.0×36.8 44.0×33.6 30.9×23.3	40.9×31.1 31.8×24.0 28.9×21.8 20.1×15.2
Resolution (Center, Corner)	160lp/mm, 80lp/mm	160lp/mm, 80lp/mm	160lp/mm, 80lp/mm
TV Distortion (%)	0.59	0.02	-0.57
Back Focus in Air (mm)	13.0	13.0	24.3
Mount	C-mount	C-mount	C-mount
Filter Thread (mm)	M55×P0.75	M40.5×P0.5	M40.5×P0.5
Size (mm)	φ57×85	φ45×79.5	φ45×89
Weight (g)	270	250	255
Temperature Range	-10°C~+50°C	-10°C~+50°C	-10°C~+50°C

LM35XC

WBMC LO-DIS FLOAT

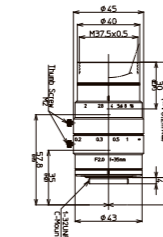

LM50XC

WBMC LO-DIS FLOAT

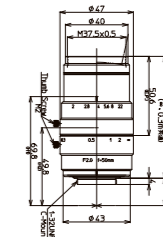

Model	LM35XC	LM50XC
Focal Length (mm)	35	50
Image Size (mm)	18.4×13.8 (Φ23)	18.4×13.8 (Φ23)
Iris Range (F-Stop)	F2.0~F16	F2.0~F22
Focusing Range (m)	0.2~∞	0.3~∞
Control	Iris: Manual Focus: Manual	Iris: Manual Focus: Manual
Shooting Range at M.O.D. (mm)	100.3 (H) × 75.3 (V)	100.2 (H) × 75.5 (V)
Angle of View (Degrees)	4/3" 29.6×22.4 1.1" 22.8×17.2 1" 20.8×15.6 2/3" 14.3×10.8	20.6×15.7 16.0×12.0 14.6×11.0 10.1×7.6
Resolution (Center, Corner)	160lp/mm, 80lp/mm	160lp/mm, 80lp/mm
TV Distortion (%)	-0.17	0.8
Back Focus in Air (mm)	15.2	21.6
Mount	C-mount	C-mount
Filter Thread (mm)	M37.5×P0.5	M37.5×P0.5
Size (mm)	φ45×74	φ47×78
Weight (g)	210	235
Temperature Range	-10°C~+50°C	-10°C~+50°C

Supported Camera Series KC1200GC4 P.8 KC1200GC3 / KC1600GC3 / KC2000GC3 / KC2400GC3 P.13

FC24M Lens Series

1.1" | 24 MEGAPIXEL 2.5 μm

Model	Format Size (Inch)								
	4/3	1.2	1.1	1	1/1.2	2/3	1/1.8	1/2	1/3
LM6FC24M	-	-	●	●	●	●	●	●	●
LM8FC24M	-	-	●	●	●	●	●	●	●
LM12FC24M	-	◇	●	●	●	●	●	●	●
LM16FC24M	-	◇	●	●	●	●	●	●	●
LM25FC24M	-	◇	●	●	●	●	●	●	●
LM35FC24M	-	◇	●	●	●	●	●	●	●
LM50FC24M	-	◇	●	●	●	●	●	●	●
LM75FC24M	-	◇	●	●	●	●	●	●	●
LM100FC24M	-	◇	●	●	●	●	●	●	●

● Compatible ◇ Suitable * Incompatible

The 75mm and 100mm models support macro shooting at magnifications of up to 0.75x. When paired with a close-up ring, they deliver high-resolution imaging at 1x.

- 2.5μm lenses offering high detail and high-resolution performance.
- The wide-band multi-coatings are specifically engineered to minimize ghosting and flaring while optimizing transmission in the near-infrared range.
- Kowa's Floating Mechanism design is incorporated into all FC24M series models to effectively minimize aberrations from close object distances to infinity.
- 1.1" format and 24MP resolution.

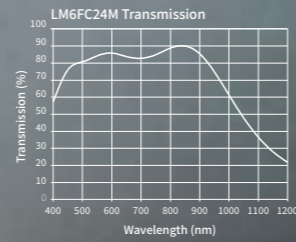

LM16FC24M

WBMC LO-DIS FLOAT XD



LM25FC24M

WBMC LO-DIS FLOAT XD



LM35FC24M

WBMC LO-DIS FLOAT

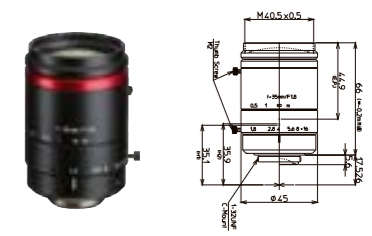

Model	LM16FC24M	LM25FC24M	LM35FC24M
Focal Length (mm)	16	25	35
Image Size (mm)	14.1×10.6 (Φ17.6)	14.1×10.6 (Φ17.6)	14.1×10.6 (Φ17.6)
Iris Range (F-Stop)	F1.8~F16	F1.8~F16	F1.8~F16
Focusing Range (m)	0.1~∞	0.1~∞	0.2~∞
Control	Iris Focus	Manual Manual	Manual Manual
Shooting Range at M.O.D. (mm)	102 (H) × 77 (V)	64 (H) × 48 (V)	84 (H) × 63 (V)
Angle of View (Degrees)	1.1" 48.0×36.7 1" 43.6×33.4 2/3" 30.8×23.3	31.5×23.9 28.7×21.7 20.0×15.0	22.1×16.7 20.2×15.2 14.0×10.5
Resolution (Center, Corner)	200lp/mm, 100lp/mm	200lp/mm, 100lp/mm	200lp/mm, 100lp/mm
TV Distortion (%)	-0.4	-0.3	0.01
Back Focus in Air (mm)	11.9	13.3	15.5
Mount	C-mount	C-mount	C-mount
Filter Thread (mm)	M35.5×P0.5	M35.5×P0.5	M40.5×P0.5
Size (mm)	φ43×65.5 (Min.) / φ43×65.7 (Max.)	φ45×67.9 (Min.) / φ45×69.4 (Max.)	φ45×66
Weight (g)	200	220	205
Temperature Range	-10°C~+50°C	-10°C~+50°C	-10°C~+50°C

LM6FC24M

WBMC LO-DIS FLOAT XD



LM8FC24M

WBMC LO-DIS FLOAT XD



LM12FC24M

WBMC LO-DIS FLOAT XD



Model	LM6FC24M	LM8FC24M	LM12FC24M
Focal Length (mm)	6.5	8.5	12
Image Size (mm)	14.1×10.6 (Φ17.6)	14.1×10.6 (Φ17.6)	14.1×10.6 (Φ17.6)
Iris Range (F-Stop)	F2.5~F16	F2.5~F16	F1.8~F16
Focusing Range (m)	0.1~∞	0.1~∞	0.1~∞
Control	Iris Focus	Manual Manual	Manual Manual
Shooting Range at M.O.D. (mm)	256 (H) × 190 (V)	184 (H) × 138 (V)	135 (H) × 101 (V)
Angle of View (Degrees)	1.1" 95.7×78.7 1" 89.9×73.0 2/3" 68.1×53.5	79.2×63.8 73.9×58.8 54.5×42.1	60.0×46.9 55.3×42.9 39.6×30.1
Resolution (Center, Corner)	200lp/mm, 100lp/mm	200lp/mm, 100lp/mm	200lp/mm, 100lp/mm
TV Distortion (%)	-1.51	0.55	0.26
Back Focus in Air (mm)	10.9	12.9	14.5
Mount	C-mount	C-mount	C-mount
Filter Thread (mm)	M82×P0.75	M62×P0.75	M49×P0.75
Size (mm)	φ84×79.1	φ64×73.3	φ51×71.7 (Min.) / φ51×73.8 (Max.)
Weight (g)	300	230	260
Temperature Range	-10°C~+50°C	-10°C~+50°C	-10°C~+50°C

LM50FC24M

WBMC LO-DIS FLOAT XD



LM75FC24M

WBMC LO-DIS FLOAT XD

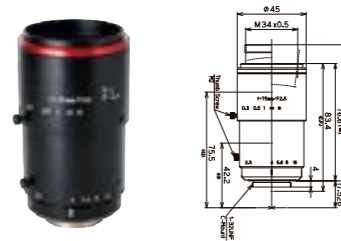

LM100FC24M

WBMC LO-DIS FLOAT XD

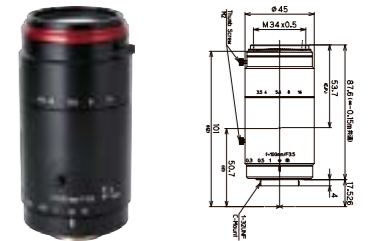

Model	LM50FC24M	LM75FC24M	LM100FC24M
Focal Length (mm)	50	75	100
Image Size (mm)	14.1×10.6 (Φ17.6)	14.1×10.6 (Φ17.6)	14.1×10.6 (Φ17.6)
Iris Range (F-Stop)	F1.8~F16	F2.5~F16	F3.5~F16
Focusing Range (m)	0.2~∞	0.15~∞	0.15~∞
Control	Iris Focus	Manual Manual	Manual Manual
Shooting Range at M.O.D. (mm)	59 (H) × 44 (V)	21 (H) × 16 (V)	19 (H) × 14 (V)
Angle of View (Degrees)	1.1" 16.1×12.1 1" 14.6×11.0 2/3" 10.1×7.6	10.7×8.0 9.7×7.3 6.7×5.0	7.9×6.0 7.2×5.4 5.0×3.7
Resolution (Center, Corner)	200lp/mm, 100lp/mm	200lp/mm, 100lp/mm	200lp/mm, 100lp/mm
TV Distortion (%)	-0.03	0.16	0.26
Back Focus in Air (mm)	14.8	20.8	21.1
Mount	C-mount	C-mount	C-mount
Filter Thread (mm)	M40.5×P0.5	M34.0×P0.5	M34.0×P0.5
Size (mm)	φ45×74.5	φ45×76.6 (Min.) / φ45×88.9 (Max.)	φ45×87.6
Weight (g)	205	225	260
Temperature Range	-10°C~+50°C	-10°C~+50°C	-10°C~+50°C

Supported Camera Series KC1200GC4 P.8 KC1200GC3 / KC1600GC3 / KC2000GC3 / KC2400GC3 P.13

HC Lens Series

1" | 1 MEGAPIXEL+

Model	Format Size (Inch)						
	4/3	1.2	1.1	1	1/1.2	2/3	1/1.8
LM4HC	-	-	-	●	●	●	●
LM6HC	-	-	-	●	●	●	●
LM8HC	-	-	-	●	●	●	●
LM12HC	-	-	◇	●	●	●	●
LM16HC	-	-	◇	●	●	●	●
LM25HC	-	◇	◇	●	●	●	●
LM35HC	-	◇	◇	●	●	●	●
LM50HC	-	-	◇	●	●	●	●
LM75HC	-	-	◇	●	●	●	●

● Compatible ◇ Suitable * Incompatible

- An advanced optical design is utilized to deliver exceptional brightness and high performance.
- Corner light intensity has been significantly enhanced compared to lenses in the JC Series and similar models.
- A comprehensive range of focal lengths is offered to support the shift toward high-resolution imaging in machine vision applications.
- Supports image processing system optimization.
- Equipped with standard thumbscrews as the locking mechanism and precise numbered scales for improved focus and iris control.



LM12HC

LO-DIS

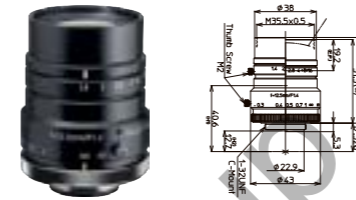

LM16HC

LO-DIS

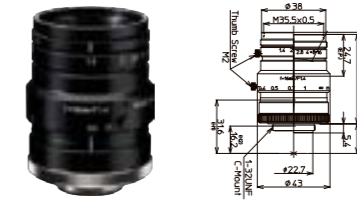

LM25HC

LO-DIS

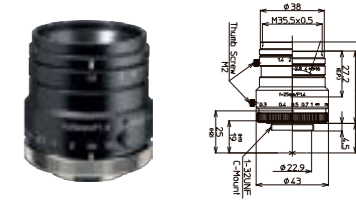

Model	LM12HC	LM16HC	LM25HC
Focal Length (mm)	12.5	16	25
Image Size (mm)	12.8×9.6 (Φ16)	12.8×9.6 (Φ16)	12.8×9.6 (Φ16)
Iris Range (F-Stop)	F1.4~F16	F1.4~F16	F1.4~F16
Focusing Range (m)	0.3~∞	0.3~∞	0.3~∞
Control	Iris Focus	Manual Manual	Manual Manual
Shooting Range at M.O.D. (mm)	330.6 (H) × 243.5 (V)	251.5 (H) × 186.2 (V)	160.7 (H) × 119.2 (V)
Angle of View (Degrees)	1" 55.6×42.5 2/3" 39.1×29.5 1/1.8" 32.1×24.2	44.3×33.6 30.8×23.2 25.3×19.0	29.3×22.0 20.2×15.1 16.5×12.4
Resolution (Center, Corner)	100lp/mm, 80lp/mm	100lp/mm, 80lp/mm	100lp/mm, 80lp/mm
TV Distortion (%)	-1.58	-1.0	-1.0
Back Focus in Air (mm)	12.6	12.6	16.5
Mount	C-mount	C-mount	C-mount
Filter Thread (mm)	M35.5×P0.5	M35.5×P0.5	M35.5×P0.5
Size (mm)	φ43×51.5 (Min.) / φ43×52.75 (Max.)	φ43×52.9 (Min.) / φ43×54.15 (Max.)	φ43×43 (Min.) / φ43×48.42 (Max.)
Weight (g)	160	150	135
Temperature Range	-10°C~+50°C	-10°C~+50°C	-10°C~+50°C

LM4HC

LO-DIS FLOAT XD

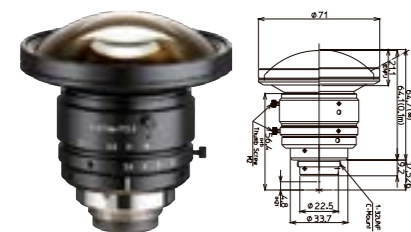

LM6HC

LO-DIS

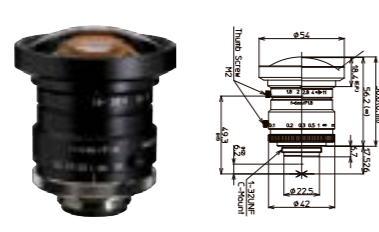

LM8HC

LO-DIS

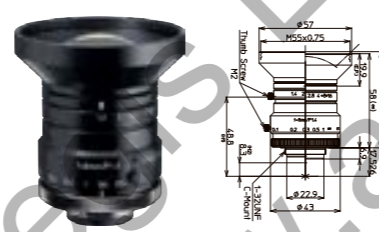

Model	LM4HC	LM6HC	LM8HC
Focal Length (mm)	4.7	6	8
Image Size (mm)	12.8×9.6 (Φ16)	12.8×9.6 (Φ16)	12.8×9.6 (Φ16)
Iris Range (F-Stop)	F2.4~F11	F1.4~F11	F1.4~F16
Focusing Range (m)	0.1~∞	0.1~∞	0.1~∞
Control	Iris Focus	Manual Manual	Manual Manual
Shooting Range at M.O.D. (mm)	375.6 (H) × 272.1 (V)	267.4 (H) × 196.3 (V)	196.0 (H) × 143.2 (V)
Angle of View (Degrees)	1" 112.2×95.4 2/3" 90.0×72.2 1/1.8" 77.4×60.8	96.8×79.4 74.1×58.0 62.6×48.2	79.4×63.0 58.3×44.7 48.5×36.9
Resolution (Center, Corner)	100lp/mm, 50lp/mm	100lp/mm, 80lp/mm	100lp/mm, 80lp/mm
TV Distortion (%)	-0.58	-0.2	-1.2
Back Focus in Air (mm)	9.0	11.1	11.2
Mount	C-mount	C-mount	C-mount
Filter Thread (mm)	-	-	M55×P0.75
Size (mm)	φ71×64.1 (Min.) / φ71×64.7 (Max.)	φ54×56.2 (Min.) / φ54×56.6 (Max.)	φ57×58 (Min.) / φ57×59.25 (Max.)
Weight (g)	360	215	205
Temperature Range	-10°C~+50°C	-10°C~+50°C	-10°C~+50°C

LM35HC

LO-DIS

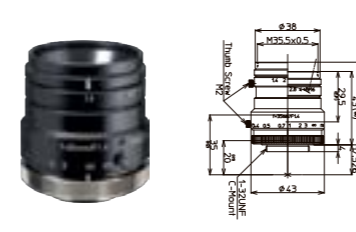

LM50HC

LO-DIS

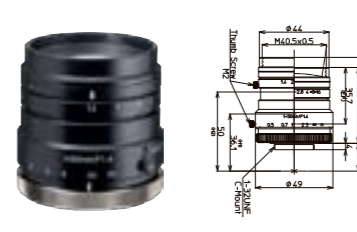

LM75HC

LO-DIS

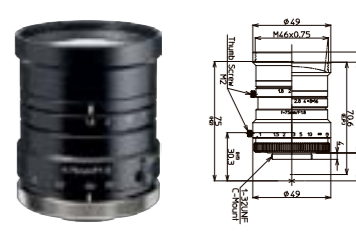

Model	LM35HC	LM50HC	LM75HC
Focal Length (mm)	35	50	75
Image Size (mm)	12.8×9.6 (Φ16)	12.8×9.6 (Φ16)	12.8×9.6 (Φ16)
Iris Range (F-Stop)	F1.4~F16	F1.4~F16	F1.8~F16
Focusing Range (m)	0.3~∞	0.5~∞	1.0~∞
Control	Iris Focus	Manual Manual	Manual Manual
Shooting Range at M.O.D. (mm)	110.1 (H) × 82.0 (V)	121.8 (H) × 91.3 (V)	165.5 (H) × 123.9 (V)
Angle of View (Degrees)	1" 20.9×15.8 2/3" 14.4×10.8 1/1.8" 11.8×8.8	14.5×10.8 10.0×7.5 8.2×6.2	9.7×7.3 6.7×5.0 5.5×4.1
Resolution (Center, Corner)	100lp/mm, 80lp/mm	100lp/mm, 80lp/mm	100lp/mm, 80lp/mm
TV Distortion (%)	-0.5	0.05	-0.2
Back Focus in Air (mm)	16.8	14.8	14.5
Mount	C-mount	C-mount	C-mount
Filter Thread (mm)	M35.5×P0.5	M40.5×P0.5	M46×P0.75
Size (mm)	φ43×43 (Min.) / φ43×48.42 (Max.)	φ49×48 (Min.) / φ49×54.4 (Max.)	φ49×57 (Min.) / φ49×63.4 (Max.)
Weight (g)	135	210	195
Temperature Range	-10°C~+50°C	-10°C~+50°C	-10°C~+50°C

JC10M Lens Series

2/3" | 10 MEGAPIXEL 2.4 μm

Model	Format Size (Inch)								
	4/3	1.2	1.1	1	1/1.2	2/3	1/1.8	1/2	1/3
LM3JC10M	-	-	-	◊	●	●	●	●	●
LM5JC10M	-	-	-	◊	●	●	●	●	●
LM8JC10M	-	-	-	◊	●	●	●	●	●
LM12JC10M	-	-	-	◊	●	●	●	●	●
LM16JC10M	-	-	-	◊	●	●	●	●	●
LM25JC10M	-	-	-	◊	●	●	●	●	●
LM35JC10M	-	-	-	◊	●	●	●	●	●
LM50JC10M	-	-	-	◊	●	●	●	●	●

● Compatible ◊ Suitable * Incompatible

- To achieve high contrast and ultra-high resolution at 2.4μm, multiple specialized optical lens elements are employed to ensure exceptional image quality.
- Kowa's Floating Mechanism design is incorporated into all JC10M series models to effectively minimize aberrations from close object distances to infinity.
- High precision aspherical lenses provide both low distortion and superior resolution.
- The wide-band multi-coatings are specifically engineered to minimize ghosting and flaring while optimizing transmission in the near-infrared range.

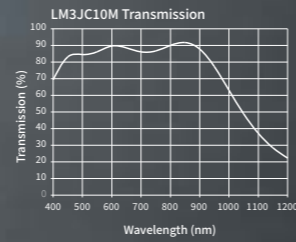

LM8JC10M

WBMC LO-DIS FLOAT XD



LM12JC10M

WBMC LO-DIS FLOAT XD

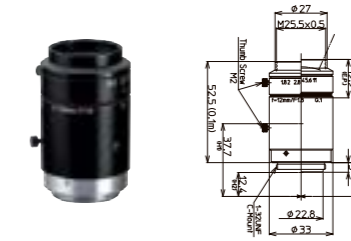

LM16JC10M

WBMC LO-DIS FLOAT

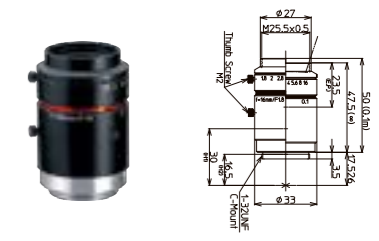

Model	LM8JC10M	LM12JC10M	LM16JC10M
Focal Length (mm)	8.5	12	16
Image Size (mm)	8.8×6.6 (Φ11)	8.8×6.6 (Φ11)	8.8×6.6 (Φ11)
Iris Range (F-Stop)	F1.8~F22	F1.8~F11	F1.8~F16
Focusing Range (m)	0.1~∞	0.1~∞	0.1~∞
Control	Iris Focus	Manual Manual	Manual Manual
Shooting Range at M.O.D. (mm)	133.2 (H) × 99.6 (V)	80.7 (H) × 60.2 (V)	61.1 (H) × 45.7 (V)
Angle of View (Degrees)	2/3" 54.0×41.9 1/1.8" 45.3×34.8 1/2" 40.8×31.2	39.1×29.8 32.4×24.6 28.9×21.9	30.0×22.7 24.7×18.6 22.0×16.6
Resolution (Center, Corner)	200lp/mm, 140lp/mm	200lp/mm, 140lp/mm	200lp/mm, 140lp/mm
TV Distortion (%)	0.31	-0.12	-0.2
Back Focus in Air (mm)	12.1	13.9	14.6
Mount	C-mount	C-mount	C-mount
Filter Thread (mm)	M34×P0.5	M25.5×P0.5	M25.5×P0.5
Size (mm)	Φ36×56	Φ33×52.5 (Min.) / Φ33×53.5 (Max.)	Φ33×47.5 (Min.) / Φ33×50 (Max.)
Weight (g)	115	105	90
Temperature Range	-10°C~+50°C	-10°C~+50°C	-10°C~+50°C

LM3JC10M

WBMC LO-DIS FLOAT XD

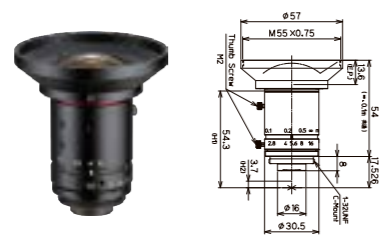

LM5JC10M

WBMC LO-DIS FLOAT XD

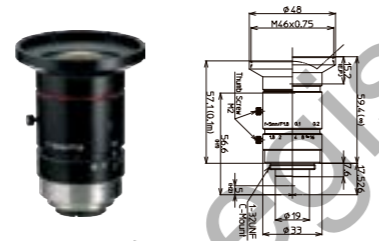

Model	LM3JC10M	LM5JC10M
Focal Length (mm)	3.7	5
Image Size (mm)	8.8×6.6 (Φ11)	8.8×6.6 (Φ11)
Iris Range (F-Stop)	F2.8~F16	F1.8~F16
Focusing Range (m)	0.1~∞	0.1~∞
Control	Iris Focus	Manual Manual
Shooting Range at M.O.D. (mm)	278.7 (H) × 207.3 (V)	197.0 (H) × 147.0 (V)
Angle of View (Degrees)	2/3" 100.2×83.7 1/1.8" 88.7×72.4 1/2" 82.0×66.1	82.2×66.5 71.1×56.5 64.9×51.1
Resolution (Center, Corner)	200lp/mm, 125lp/mm	200lp/mm, 140lp/mm
TV Distortion (%)	-0.09	-0.33
Back Focus in Air (mm)	9.9	10.3
Mount	C-mount	C-mount
Filter Thread (mm)	M55×P0.75	M46×P0.75
Size (mm)	Φ57×54	Φ48×57.01 (Min.) / Φ48×59.4 (Max.)
Weight (g)	120	120
Temperature Range	-10°C~+50°C	-10°C~+50°C

LM25JC10M

WBMC LO-DIS FLOAT

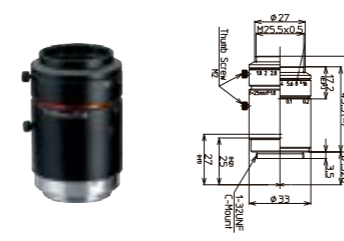

LM35JC10M

WBMC LO-DIS FLOAT

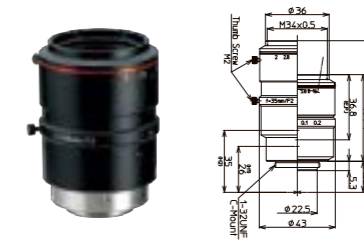

LM50JC10M

WBMC LO-DIS FLOAT XD

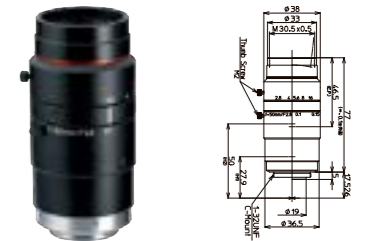

Model	LM25JC10M	LM35JC10M	LM50JC10M
Focal Length (mm)	25	35	50
Image Size (mm)	8.8×6.6 (Φ11)	8.8×6.6 (Φ11)	8.8×6.6 (Φ11)
Iris Range (F-Stop)	F1.8~F16	F2.0~F16	F2.8~F16
Focusing Range (m)	0.1~∞	0.1~∞	0.1~∞
Control	Iris Focus	Manual Manual	Manual Manual
Shooting Range at M.O.D. (mm)	36.7 (H) × 27.5 (V)	23.4 (H) × 17.6 (V)	19.1 (H) × 14.3 (V)
Angle of View (Degrees)	2/3" 20.0×15.1 1/1.8" 16.4×12.3 1/2" 14.6×11.0	14.3×10.8 11.7×8.8 10.4×7.8	10.1×7.6 8.2×6.1 7.3×5.5
Resolution (Center, Corner)	200lp/mm, 140lp/mm	200lp/mm, 140lp/mm	200lp/mm, 140lp/mm
TV Distortion (%)	-0.09	0.05	-0.02
Back Focus in Air (mm)	17.9	14.2	12.8
Mount	C-mount	C-mount	C-mount
Filter Thread (mm)	M25.5×P0.5	M34×P0.5	M30.5×P0.5
Size (mm)	Φ33×45.5 (Min.) / Φ33×51.2 (Max.)	Φ43×49 (Min.) / Φ43×68.2 (Max.)	Φ38×77
Weight (g)	95	160	170
Temperature Range	-10°C~+50°C	-10°C~+50°C	-10°C~+50°C

Supported Camera Series KC800GC4 P.8 KC800GC3 P.12

JC5M2 Lens Series

2/3" | 5 MEGAPIXEL 3.45 μm

Model	Format Size (Inch)								
	4/3	1.2	1.1	1	1/1.2	2/3	1/1.8	1/2	1/3
LM12JC5M2	-	-	-	-	-	●	●	●	●
LM16JC5M2	-	-	-	-	-	●	●	●	●
LM25JC5M2	-	-	-	-	◇	●	●	●	●
LM35JC5M2	-	-	-	-	◇	●	●	●	●

● Compatible ◇ Suitable * Incompatible

- Compared to our previous models, these lenses feature a more compact, lightweight design, enabling up to 60% greater light intake at a fully open aperture (F-Stop of 1.4)*.
- Kowa's Floating Mechanism design is incorporated into all JC5M2 series models to effectively minimize aberrations from close object distances to infinity.

* In the case of the LM12JC5M2 and LM16JC5M2 models.



LM16JC5M2

LO-DIS FLOAT



Model	LM16JC5M2
Focal Length (mm)	16
Image Size (mm)	8.8×6.6 (Φ11)
Iris Range (F-Stop)	F1.4~F16
Focusing Range (m)	0.1~∞
Control	Iris Focus
	Manual Manual
Shooting Range at M.O.D. (mm)	64.6 (H) × 48.4 (V)
Angle of View (Degrees)	2/3" 29.9×22.7 1/1.8" 24.7×18.6 1/2" 22.0×16.6
Resolution (Center, Corner)	160lp/mm, 100lp/mm
TV Distortion (%)	0.03
Back Focus in Air (mm)	11.6
Mount	C-mount
Filter Thread (mm)	M30.5×P0.5
Size (mm)	φ38.5×52 (Min.) / φ38.5×57.3 (Max.)
Weight (g)	125
Temperature Range	-10°C~+50°C

LM25JC5M2

LO-DIS FLOAT



Model	LM25JC5M2
Focal Length (mm)	25
Image Size (mm)	8.8×6.6 (Φ11)
Iris Range (F-Stop)	F1.6~F16
Focusing Range (m)	0.1~∞
Control	Iris Focus
	Manual Manual
Shooting Range at M.O.D. (mm)	35.1 (H) × 26.3 (V)
Angle of View (Degrees)	2/3" 19.9×15.0 1/1.8" 16.4×12.3 1/2" 14.6×10.9
Resolution (Center, Corner)	160lp/mm, 100lp/mm
TV Distortion (%)	-0.01
Back Focus in Air (mm)	11.2
Mount	C-mount
Filter Thread (mm)	M30.5×P0.5
Size (mm)	φ38.5×45.5 (Min.) / φ38.5×54.4 (Max.)
Weight (g)	115
Temperature Range	-10°C~+50°C

LM12JC5M2

LO-DIS FLOAT

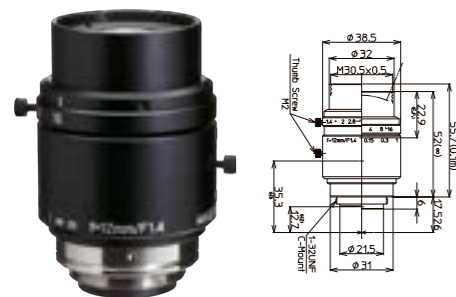

Model	LM12JC5M2
Focal Length (mm)	12.5
Image Size (mm)	8.8×6.6 (Φ11)
Iris Range (F-Stop)	F1.4~F16
Focusing Range (m)	0.1~∞
Control	Iris Focus
	Manual Manual
Shooting Range at M.O.D. (mm)	81.4 (H) × 60.9 (V)
Angle of View (Degrees)	2/3" 38.4×29.2 1/1.8" 31.7×24.0 1/2" 28.4×21.4
Resolution (Center, Corner)	160lp/mm, 100lp/mm
TV Distortion (%)	-0.06
Back Focus in Air (mm)	11.5
Mount	C-mount
Filter Thread (mm)	M30.5×P0.5
Size (mm)	φ38.5×52 (Min.) / φ38.5×55.7 (Max.)
Weight (g)	130
Temperature Range	-10°C~+50°C

LM35JC5M2

LO-DIS FLOAT



Model	LM35JC5M2
Focal Length (mm)	35
Image Size (mm)	8.8×6.6 (Φ11)
Iris Range (F-Stop)	F1.6~F16
Focusing Range (m)	0.18~∞
Control	Iris Focus
	Manual Manual
Shooting Range at M.O.D. (mm)	42.1 (H) × 31.6 (V)
Angle of View (Degrees)	2/3" 14.3×10.8 1/1.8" 11.7×8.8 1/2" 10.4×7.8
Resolution (Center, Corner)	160lp/mm, 125lp/mm
TV Distortion (%)	-0.03
Back Focus in Air (mm)	12.2
Mount	C-mount
Filter Thread (mm)	M30.5×P0.5
Size (mm)	φ38.5×48 (Min.) / φ38.5×58.6 (Max.)
Weight (g)	120
Temperature Range	-10°C~+50°C

Supported Camera Series KC300GC4 / KC500GC4 P.8 KC300XC3 / KC500XC3 P.10 KC300GC3 / KC500GC3 P.12

JC5MC Lens Series

2/3" | ULTRA COMPACT 5 MEGAPIXEL 3.45 μm

Model	Format Size (Inch)								
	4/3	1.2	1.1	1	1/1.2	2/3	1/1.8	1/2	1/3
LM8JC5MC	-	-	-	-	-	●	●	●	●
LM12JC5MC	-	-	-	-	-	●	●	●	●
LM16JC5MC	-	-	-	-	-	●	●	●	●
LM25JC5MC	-	-	-	-	-	●	●	●	●
LM35JC5MC	-	-	-	◇	◇	●	●	●	●
LM50JC5MC	-	-	-	-	-	●	●	●	●

● Compatible ◇ Suitable * Incompatible

- Including the wide-angle 8mm LM8JC5MC model with an ultra-compact total length of just 27.5mm.
- The physical size of these lenses has been reduced by approximately 50% compared to previous models in the JC5MC series.
- 2/3" format size with 5MP resolution.
- Featuring a highly compact form factor and lightweight design.
- A click-stop iris adjustment mechanism is implemented.
- Shock and vibration resistant design.



LM8JC5MC

LO-DIS RUGGED

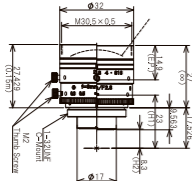

Model		LM8JC5MC
Focal Length (mm)		8
Image Size (mm)		8.8×6.6 (Φ11)
Iris Range (F-Stop)		F2.8~F16
Focusing Range (m)		0.15~∞
Control	Iris	Manual
	Focus	Manual
Shooting Range at M.O.D. (mm)		178.0 (H) × 132.0 (V)
Angle of View (Degrees)	2/3"	57.6 × 44.4
	1/1.8"	48.1 × 36.7
	1/2"	43.1 × 32.8
Resolution (Center, Corner)		160lp/mm, 100lp/mm
TV Distortion (%)		-0.85
Back Focus in Air (mm)		10.8
Mount		C-mount
Filter Thread (mm)		M30.5xP0.5
Size (mm)		φ32×27 (Min.) / φ32×27.429 (Max.)
Weight (g)		55
Temperature Range		-10°C~+50°C

LM12JC5MC

LO-DIS RUGGED

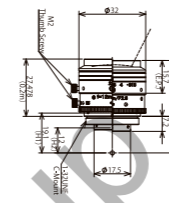

LM16JC5MC

LO-DIS RUGGED

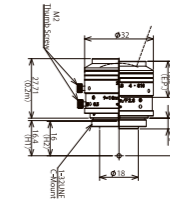

LM25JC5MC

LO-DIS RUGGED

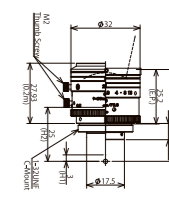

Model	LM12JC5MC	LM16JC5MC	LM25JC5MC	
Focal Length (mm)	12	16	25	
Image Size (mm)	8.8×6.6 (Φ11)	8.8×6.6 (Φ11)	8.8×6.6 (Φ11)	
Iris Range (F-Stop)	F2.8~F16	F2.8~F16	F2.8~F16	
Focusing Range (m)	0.2~∞	0.2~∞	0.2~∞	
Control	Iris	Manual	Manual	
	Focus	Manual	Manual	
Shooting Range at M.O.D. (mm)		159.0 (H) × 118.0 (V)	117.0 (H) × 88.0 (V)	75.0 (H) × 56.0 (V)
Angle of View (Degrees)	2/3"	41.0 × 31.2	30.9 × 23.4	20.0 × 15.0
	1/1.8"	33.9 × 25.6	25.5 × 19.2	16.4 × 12.4
	1/2"	30.3 × 22.8	22.7 × 17.2	14.6 × 11.0
Resolution (Center, Corner)		160lp/mm, 100lp/mm	160lp/mm, 100lp/mm	160lp/mm, 100lp/mm
TV Distortion (%)		-0.43	-0.09	0.06
Back Focus in Air (mm)		12.6	14.7	11.7
Mount		C-mount	C-mount	C-mount
Filter Thread (mm)		*1	*1	*1
Size (mm)		φ32×26.9 (Min.) / φ32×27.478 (Max.)	φ32×26.5 (Min.) / φ32×27.71 (Max.)	φ32×25 (Min.) / φ32×27.93 (Max.)
Weight (g)		55	55	55
Temperature Range		-10°C~+50°C	-10°C~+50°C	-10°C~+50°C

LM35JC5MC

LO-DIS RUGGED

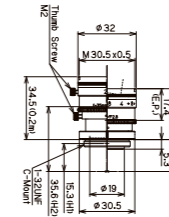

LM50JC5MC

LO-DIS XD RUGGED

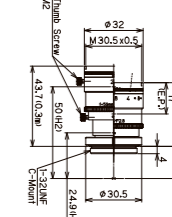

Model	LM35JC5MC	LM50JC5MC	
Focal Length (mm)	35	50	
Image Size (mm)	8.8×6.6 (Φ11)	8.8×6.6 (Φ11)	
Iris Range (F-Stop)	F2.8~F16	F2.8~F16	
Focusing Range (m)	0.2~∞	0.3~∞	
Control	Iris	Manual	
	Focus	Manual	
Shooting Range at M.O.D. (mm)		48.0 (H) × 36.0 (V)	49.0 (H) × 37.0 (V)
Angle of View (Degrees)	2/3"	14.0 × 10.6	10.0 × 7.5
	1/1.8"	11.5 × 8.7	8.2 × 6.2
	1/2"	10.3 × 7.7	7.3 × 5.5
Resolution (Center, Corner)		160lp/mm, 125lp/mm	160lp/mm, 125lp/mm
TV Distortion (%)		-0.02	-0.01
Back Focus in Air (mm)		13.3	14.9
Mount		C-mount	C-mount
Filter Thread (mm)		M30.5×P0.5	M30.5×P0.5
Size (mm)		φ32×27.9 (Min.) / φ32×34.5 (Max.)	φ32×34.7 (Min.) / φ32×43.7 (Max.)
Weight (g)		50	60
Temperature Range		-10°C~+50°C	-10°C~+50°C

Supported Camera Series KC300GC4 / KC500GC4 P.8 KC300XC3 / KC500XC3 P.10 KC300GC3 / KC500GC3 P.12

NC1M Lens Series

1/1.8" | 2 MEGAPIXEL 1/2" | 2 MEGAPIXEL

Model	Format Size (Inch)						
	4/3	1.2	1.1	1	1/1.2	2/3	1/1.8
LM3NC1M	-	-	-	-	-	●	●
LM6NC1M	-	-	-	-	-	◇	●

● Compatible ◇ Suitable * Incompatible

- Featuring ultra-wide angles of view at small focal lengths with minimal distortion.
- Engineered to achieve 2MP resolution.
- A 3.5mm focal length model with an 89.0° horizontal angle of view has been added to the lineup.
- High precision aspherical lenses provide both low distortion and high resolution. (LM3NC1M)
- A compact optical design is employed to maintain high performance and exceptional quality.
- An addition of the corner light amount is realized. (Compared with JC Series)



JC1M Lens

2/3" | 2 MEGAPIXEL

Model	Format Size (Inch)						
	4/3	1.2	1.1	1	1/1.2	2/3	1/1.8
LM5JC1M	-	-	-	-	-	●	●

● Compatible ◇ Suitable * Incompatible

- Delivers an ultra-wide angle and small focal length with minimal distortion, making it ideal for precise data capture in image processing applications.
- Capable of achieving 2MP resolution.
- Meticulously crafted aspheric lenses are engineered to provide both low distortion and high resolution.
- A compact optical design is adopted to ensure superior performance and exceptional quality.



LM3NC1M

LO-DIS

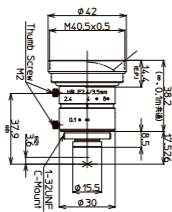

LM6NC1M

LO-DIS

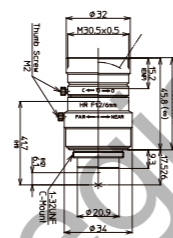

LM5JC1M

LO-DIS XD

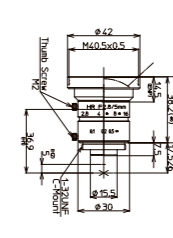

Model	LM3NC1M	LM6NC1M
Focal Length (mm)	3.5	6
Image Size (mm)	7.2×5.4 (Φ9)	6.4×4.8 (Φ8)
Iris Range (F-Stop)	F2.4~F14	F1.2~Close
Focusing Range (m)	0.1~∞	0.1~∞
Control	Iris: Manual Focus: Manual	Iris: Manual Focus: Manual
Shooting Range at M.O.D. (mm)	226.3 (H) × 171.4 (V)	122.2 (H) × 91.0 (V)
Angle of View (Degrees)	1/1.8" : 89.0×73.8 1/2" : 82.4×66.9 1/3" : 66.9×52.7	- 56.2×43.5 43.5×33.2
Resolution (Center, Corner)	100lp/mm, 80lp/mm	100lp/mm, 80lp/mm
TV Distortion (%)	0.4	-0.2
Back Focus in Air (mm)	9.7	8.2
Mount	C-mount	C-mount
Filter Thread (mm)	M40.5×P0.5	M30.5×P0.5
Size (mm)	Φ42×38.2	Φ34×45.8 (Min.) / Φ34×46.1 (Max.)
Weight (g)	85	100
Temperature Range	-10°C~+50°C	-10°C~+50°C

Model	LM5JC1M
Focal Length (mm)	5
Image Size (mm)	8.8×6.6 (Φ11)
Iris Range (F-Stop)	F2.8~F16
Focusing Range (m)	0.1~∞
Control	Iris: Manual Focus: Manual
Shooting Range at M.O.D. (mm)	200.8 (H) × 150.8 (V)
Angle of View (Degrees)	2/3" : 82.4×66.9 1/1.8" : 71.7×57.1 1/2" : 65.2×51.3
Resolution (Center, Corner)	100lp/mm, 80lp/mm
TV Distortion (%)	0.5
Back Focus in Air (mm)	10.0
Mount	C-mount
Filter Thread (mm)	M40.5×P0.5
Size (mm)	Φ42×38.2 (Min.) / Φ42×38.4 (Max.)
Weight (g)	84
Temperature Range	-10°C~+50°C

Supported Camera Series KC48GC4 / KC130GC4 / KC200GC4 / KC300GC4 P.7-8 KC130XC2 / KC300XC3 P.10 KC48GC3 / KC130GC3 / KC200GC3 / KC300GC3 P.12

Supported Camera Series KC48GC4 / KC130GC4 / KC300GC4 P.7-8 KC130XC2 / KC300XC3 P.10 KC48GC3 / KC130GC3 / KC300GC3 P.12

JC1MS Lens Series

2/3" | 2 MEGAPIXEL

Model	Format Size (Inch)								
	4/3	1.2	1.1	1	1/1.2	2/3	1/1.8	1/2	1/3
LM8JC1MS	-	-	-	-	-	●	●	●	●
LM12JC1MS	-	-	-	-	-	●	●	●	●
LM16JC1MS	-	-	-	-	-	●	●	●	●
LM25JC1MS	-	-	-	-	-	●	●	●	●
LM35JC1MS	-	-	-	-	-	●	●	●	●
LM50JC1MS	-	-	-	-	-	●	●	●	●
LM75JC1MS	-	-	-	-	-	●	●	●	●
LM100JC1MS	-	-	-	-	-	●	●	●	●

● Compatible ◇ Suitable * Incompatible

- 2/3" format size (φ11mm) with 2MP resolution.
- Engineered for low distortion, making it ideal for accurate data capture in image processing.
- Incorporates an optical design optimized for exceptional brightness and high performance.
- Kowa's Floating Mechanism system is partially integrated into the optical design to support a broad range of applications.



LM16JC1MS

LO-DIS FLOAT



LM25JC1MS

LO-DIS FLOAT

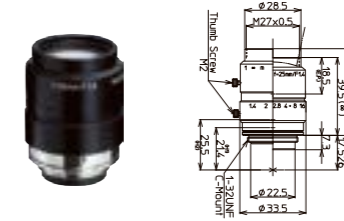

LM35JC1MS

LO-DIS FLOAT

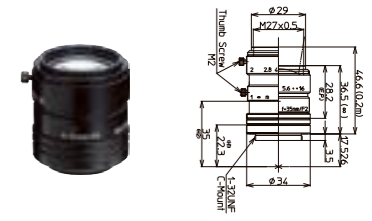

Model	LM16JC1MS	LM25JC1MS	LM35JC1MS
Focal Length (mm)	16	25	35
Image Size (mm)	8.8×6.6 (Φ11)	8.8×6.6 (Φ11)	8.8×6.6 (Φ11)
Iris Range (F-Stop)	F1.4~F16	F1.4~F16	F2.0~F16
Focusing Range (m)	0.2~∞	0.2~∞	0.2~∞
Control	Iris Focus	Manual Manual	Manual Manual
Shooting Range at M.O.D. (mm)	112.8 (H) × 84.4 (V)	71.1 (H) × 53.3 (V)	47.9 (H) × 35.8 (V)
Angle of View (Degrees)	2/3" 30.0 × 22.7 1/1.8" 24.7 × 18.6 1/2" 21.8 × 16.4	19.6 × 14.8 16.1 × 12.1 14.0 × 10.5	14.4 × 10.8 11.8 × 8.8 10.5 × 7.9
Resolution (Center, Corner)	100lp/mm, 80lp/mm	100lp/mm, 80lp/mm	100lp/mm, 80lp/mm
TV Distortion (%)	-0.05	-0.04	-0.2
Back Focus in Air (mm)	13.1	11.7	20.1
Mount	C-mount	C-mount	C-mount
Filter Thread (mm)	M27×P0.5	M27×P0.5	M27×P0.5
Size (mm)	Φ33.5×36.5 (Min.) / Φ33.5×38.6 (Max.)	Φ33.5×39.5 (Min.) / Φ33.5×44 (Max.)	Φ34×36.5 (Min.) / Φ34×46.6 (Max.)
Weight (g)	85	90	70
Temperature Range	-10°C~+50°C	-10°C~+50°C	-10°C~+50°C

LM8JC1MS

LO-DIS XD

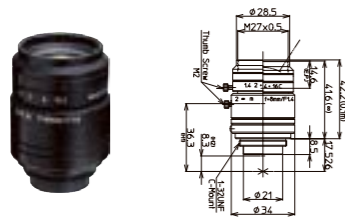

LM12JC1MS

LO-DIS XD

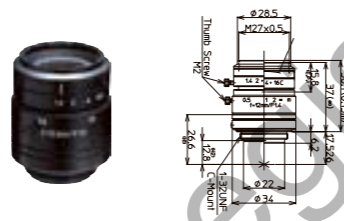

Model	LM8JC1MS	LM12JC1MS
Focal Length (mm)	8	12
Image Size (mm)	8.8×6.6 (Φ11)	8.8×6.6 (Φ11)
Iris Range (F-Stop)	F1.4~Close	F1.4~Close
Focusing Range (m)	0.1~∞	0.15~∞
Control	Iris Focus	Manual Manual
Shooting Range at M.O.D. (mm)	120.3 (H) × 90.0 (V)	110.0 (H) × 82.5 (V)
Angle of View (Degrees)	2/3" 56.5 × 43.9 1/1.8" 47.4 × 36.3 1/2" 42.6 × 32.5	38.3 × 29.1 31.7 × 24.0 28.3 × 21.4
Resolution (Center, Corner)	100lp/mm, 80lp/mm	100lp/mm, 80lp/mm
TV Distortion (%)	-0.6	-0.07
Back Focus in Air (mm)	9.74	11.7
Mount	C-mount	C-mount
Filter Thread (mm)	M27×P0.5	M27×P0.5
Size (mm)	Φ34 × 41.6 (Min.) / Φ34 × 42.2 (Max.)	Φ34 × 37 (Min.) / Φ34 × 38.1 (Max.)
Weight (g)	90	85
Temperature Range	-10°C~+50°C	-10°C~+50°C

LM50JC1MS

LO-DIS FLOAT

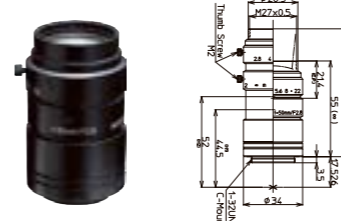

LM75JC1MS

LO-DIS

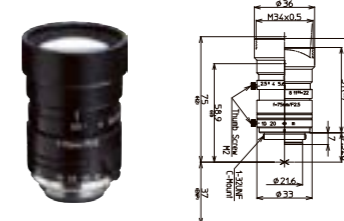

LM100JC1MS

LO-DIS

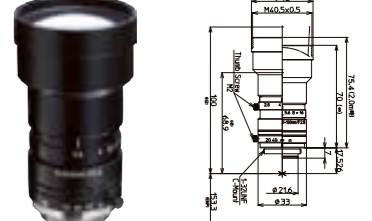

Model	LM50JC1MS	LM75JC1MS	LM100JC1MS
Focal Length (mm)	50	75	100
Image Size (mm)	8.8×6.6 (Φ11)	8.8×6.6 (Φ11)	8.8×6.6 (Φ11)
Iris Range (F-Stop)	F2.8~F22	F2.5~F22	F2.8~F32
Focusing Range (m)	0.2~∞	1.2~∞	2.0~∞
Control	Iris Focus	Manual Manual	Manual Manual
Shooting Range at M.O.D. (mm)	29.3 (H) × 21.9 (V)	132.6 (H) × 99.6 (V)	168.8 (H) × 126.6 (V)
Angle of View (Degrees)	2/3" 9.6 × 7.2 1/1.8" 7.9 × 5.9 1/2" 7.0 × 5.2	6.7 × 5.0 5.5 × 4.1 4.9 × 3.7	5.0 × 3.8 4.1 × 3.1 3.7 × 2.8
Resolution (Center, Corner)	100lp/mm, 80lp/mm	100lp/mm, 80lp/mm	100lp/mm, 80lp/mm
TV Distortion (%)	-0.03	-0.1	-0.05
Back Focus in Air (mm)	35.5	18.0	19.0
Mount	C-mount	C-mount	C-mount
Filter Thread (mm)	M27×P0.5	M34×P0.5	M40.5×P0.5
Size (mm)	Φ34 × 55 (Min.) / Φ34 × 73.5 (Max.)	Φ36 × 51 (Min.) / Φ36 × 56.42 (Max.)	Φ42 × 70 (Min.) / Φ42 × 75.4 (Max.)
Weight (g)	95	105	145
Temperature Range	-10°C~+50°C	-10°C~+50°C	-10°C~+50°C

Supported Camera Series KC48GC4 / KC130GC4 / KC200GC4 / KC300GC4 P.7-8 KC130XC2 / KC300XC3 P.10 KC48GC3 / KC130GC3 / KC200GC3 / KC300GC3 P.12

JC Lens Series

2/3" | VGA+

Model	Format Size (Inch)								
	4/3	1.2	1.1	1	1/1.2	2/3	1/1.8	1/2	1/3
LM6JC	-	-	-	-	-	●	●	●	●
LM8JC	-	-	-	-	-	●	●	●	●
LM12JC	-	-	-	-	-	●	●	●	●
LM16JC	-	-	-	-	-	●	●	●	●
LM25JC	-	-	-	-	-	●	●	●	●
LM35JC	-	-	-	-	-	●	●	●	●
LM50JC	-	-	◇	◇	◇	●	●	●	●

● Compatible ◇ Suitable * Incompatible

- Provides excellent cost-performance value.
- Compatible with format sizes up to 2/3".
- Delivers bright images with a low F-Stop for enhanced clarity.



LM6JC

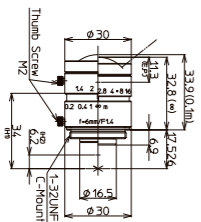

Model		LM6JC
Focal Length (mm)		6
Image Size (mm)		8.8×6.6 (Φ11)
Iris Range (F-Stop)		F1.4~F16
Focusing Range (m)		0.1~∞
Control	Iris	Manual
	Focus	Manual
Shooting Range at M.O.D. (mm)		190.6 (H) × 130.3 (V)
Angle of View (Degrees)	2/3"	81.9 × 61.2
	1/1.8"	66.9 × 50.1
	1/2"	59.4 × 44.5
Resolution (Center, Corner)		100lp/mm, 40lp/mm
TV Distortion (%)		-10.7
Back Focus in Air (mm)		11.3
Mount		C-mount
Filter Thread (mm)		-
Size (mm)		φ30 × 32.8 (Min.) / φ30 × 33.9 (Max.)
Weight (g)		65
Temperature Range		-10°C~+50°C

LM8JC

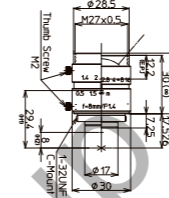

LM12JC

LO-DIS

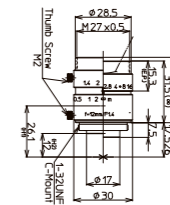

LM16JC

LO-DIS

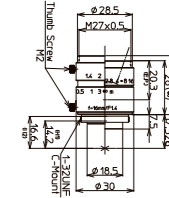

Model		LM8JC	LM12JC	LM16JC
Focal Length (mm)		8	12	16
Image Size (mm)		8.8×6.6 (Φ11)	8.8×6.6 (Φ11)	8.8×6.6 (Φ11)
Iris Range (F-Stop)		F1.4~F16	F1.4~F16	F1.4~F16
Focusing Range (m)		0.1~∞	0.1~∞	0.2~∞
Control	Iris	Manual	Manual	Manual
	Focus	Manual	Manual	Manual
Shooting Range at M.O.D. (mm)		136.0 (H) × 96.1 (V)	81.1 (H) × 59.4 (V)	111.8 (H) × 82.6 (V)
Angle of View (Degrees)	2/3"	64.2 × 47.7	42.5 × 31.7	30.5 × 22.8
	1/1.8"	52.4 × 39.1	34.6 × 25.9	23.8 × 18.7
	1/2"	46.2 × 34.6	30.7 × 23.0	22.2 × 16.6
Resolution (Center, Corner)		100lp/mm, 40lp/mm	100lp/mm, 40lp/mm	100lp/mm, 40lp/mm
TV Distortion (%)		-6.2	-2.5	-1.5
Back Focus in Air (mm)		11.3	11.1	12.1
Mount		C-mount	C-mount	C-mount
Filter Thread (mm)		M27 × P0.5	M27 × P0.5	M27 × P0.5
Size (mm)		φ30 × 30 (Min.) / φ30 × 31.13 (Max.)	φ30 × 31.5 (Min.) / φ30 × 33.38 (Max.)	φ30 × 28 (Min.) / φ30 × 30.6 (Max.)
Weight (g)		60	60	55
Temperature Range		-10°C~+50°C	-10°C~+50°C	-10°C~+50°C

LM25JC

LO-DIS

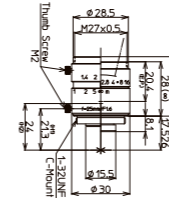

LM35JC

LO-DIS

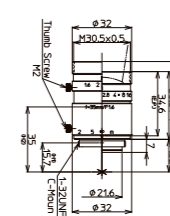

LM50JC

LO-DIS

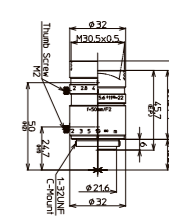

Model		LM25JC	LM35JC	LM50JC
Focal Length (mm)		25	35	50
Image Size (mm)		8.8×6.6 (Φ11)	8.8×6.6 (Φ11)	8.8×6.6 (Φ11)
Iris Range (F-Stop)		F1.6~F16	F1.6~F16	F2.0~F22
Focusing Range (m)		0.2~∞	0.3~∞	0.5~∞
Control	Iris	Manual	Manual	Manual
	Focus	Manual	Manual	Manual
Shooting Range at M.O.D. (mm)		72.1 (H) × 53.7 (V)	76.0 (H) × 56.9 (V)	85.0 (H) × 63.6 (V)
Angle of View (Degrees)	2/3"	21.0 × 15.7	14.4 × 10.8	10.1 × 7.6
	1/1.8"	17.2 × 12.9	11.8 × 8.8	8.2 × 6.2
	1/2"	15.3 × 11.4	10.5 × 7.9	7.3 × 5.5
Resolution (Center, Corner)		100lp/mm, 40lp/mm	100lp/mm, 40lp/mm	100lp/mm, 40lp/mm
TV Distortion (%)		-0.6	-0.2	-0.1
Back Focus in Air (mm)		10.3	14.9	17.2
Mount		C-mount	C-mount	C-mount
Filter Thread (mm)		M27 × P0.5	M30.5 × P0.5	M30.5 × P0.5
Size (mm)		φ30 × 28 (Min.) / φ30 × 30.63 (Max.)	φ32 × 36.5 (Min.) / φ32 × 41.9 (Max.)	φ32 × 39.5 (Min.) / φ32 × 44.92 (Max.)
Weight (g)		55	85	90
Temperature Range		-10°C~+50°C	-10°C~+50°C	-10°C~+50°C

Radiation Resistant Lens Series

1.1" | WATER AND DUST RADIATION RESISTANCE 24 MEGAPIXEL 2.5 μm
 2/3" | RADIATION RESISTANCE ZOOM LENS

Model	Format Size (Inch)					
	4/3	1.2	1.1	1	1/1.2	1/2
LM15FC-R	○	○	●	●	●	●
LMZ1166M3-R	-	-	-	-	●	●

● Compatible ○ Suitable * Incompatible



- Fixed focal length lens.
- Radiation resistant glass is utilized to prevent colorization (anti-browning) in radiation prone environments.
- Ideal for long-term use in radiation related facilities and/or in outer space.
- Mechanical design engineered for superior water resistant and dust resistant protection.
- A two-way reversible nut is employed for precise focus adjustment.

- Zoom lens.
- Radiation resistant glass is utilized to prevent colorization (anti-browning) in radiation prone environments.
- Ideal for long-term use in radiation related facilities and/or in outer space.



Standard lens showing browning after being subjected to gamma rays.

As shown in the figure on the left, lenses irradiated by radiation experience significant colorization, blocking nearly all visible-range light. The LM15FC-R, utilizing radiation resistant glass, minimizes this colorization, enabling long-term use in radiation exposed environments.

LM15FC-R

LO-DIS WATER DUST

Build to order products

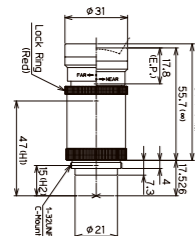

Model	LM15FC-R	
Focal Length (mm)	15	
Image Size (mm)	14.1 × 10.6 (Φ17.6)	
Iris Range (F-Stop)	F2.8/F4/F6/F10	
Focusing Range (m)	0.1~∞	
Control	Iris Focus	
	Manual	
Shooting Range at M.O.D. (mm)	108 (H) × 80 (V)	
Angle of View (Degrees)	1.1"	52.3 × 39.8
	1"	47.7 × 36.1
	2/3"	33.1 × 25.0
Resolution (Center, Corner)	200lp/mm, 125lp/mm	
TV Distortion (%)	-2.12	
Back Focus in Air (mm)	16.3	
Mount	C-mount	
Size (mm)	Φ31 × 55.7 (Min.) / Φ31 × 57.7 (Max.)	
Weight (g)	70	
Temperature Range	-10°C ~ +50°C	

LMZ1166M3-R

Build to order products

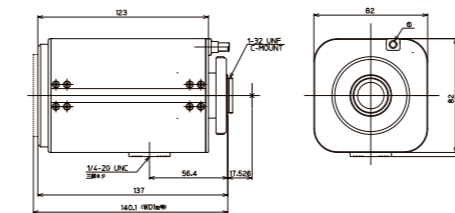

Model	LMZ1166M3-R	
Focal Length (mm)	11 - 66	
Image Size (mm)	Φ12.2	
Iris Range (F-Stop)	F2.8~F16	
Focusing Range (m)	1.0~∞	
Control	Iris Focus Zoom	
	Motorized Motorized Motorized	
Angle of View (Degrees)	2/3"	WIDE 45.9 × 34.8 / TELE 7.7 × 5.8
	1/2"	WIDE 33.8 × 25.5 / TELE 5.7 × 4.3
TV Distortion (%)	-	
Back Focus in Air (mm)	15.5	
Mount	C-mount	
Size (mm)	82 × 85 × 137	
Weight (g)	1,150	
Temperature Range	-10°C ~ +50°C	

HC-V Lens Series

1" | RUGGEDIZED 1 MEGAPIXEL+

Model	Format Size (Inch)						
	4/3	1.2	1.1	1	1/1.2	2/3	1/1.8
LM6HC-V	-	-	-	●	●	●	●
LM8HC-V	-	-	-	●	●	●	●
LM12HC-V	-	-	◇	●	●	●	●
LM16HC-V	-	-	◇	●	●	●	●
LM25HC-V	-	◇	◇	●	●	●	●
LM35HC-V	-	◇	◇	●	●	●	●
LM50HC-V	-	◇	◇	●	●	●	●

● Compatible ◇ Suitable * Incompatible

Based on the HC series optical design, these high-resolution lenses are perfect for large formats and deliver superior vibration and shock resistance.

- 1" format size (φ16mm) with 4MP resolution.
- Patented mechanical design, engineered for superior vibration and impact resistance.
- Fixed, interchangeable iris plates are adopted for added flexibility.
- A two-way reversible nut is used for precise focus adjustment.
- Applying adhesive to the lens barrel and elements significantly enhances vibration and shock resistance.



1. Fixed Iris Design with Interchangeable Aperture Plates

Instead of standard iris blades, interchangeable aperture plates are used to set the F-Stop. With F1.4 preinstalled in the lens, the F-Stop can be changed to F2.8, F4, or F8 using three additional aperture plates included.

* LM6HC-V has an F1.8 aperture



2. Focus Adjustment

A two-way reversible nut is used for focus adjustment. The nut on the mount side of the barrel is loosened to adjust the focus, and the focus is secured by tightening the red nut.



3. Adhesive-mounted Glass

Glass elements are securely bonded to the lens barrel with adhesive, enhancing reliability, stability, and shock and vibration resistance.

LM6HC-V

LO-DIS RUGGED



Model	LM6HC-V
Focal Length (mm)	6
Image Size (mm)	12.8×9.6 (Φ16)
Iris Range (F-Stop)	F1.8 / F2.8 / F4 / F8
Focusing Range (m)	0.1~∞
Control	Iris: - Focus: Manual
Shooting Range at M.O.D. (mm)	267.4 (H) × 196.3 (V)
Angle of View (Degrees)	1" 96.8 × 79.4 2/3" 74.1 × 58.0 1/1.8" 62.6 × 48.2
Resolution (Center, Corner)	100lp/mm, 80lp/mm
TV Distortion (%)	-0.2
Back Focus in Air (mm)	11.1
Mount	C-mount
Filter Thread (mm)	-
Size (mm)	Φ54×56.2 (Min.) / Φ54×56.5 (Max.)
Weight (g)	180
Temperature Range	-10°C~+50°C

LM8HC-V

LO-DIS RUGGED



LM12HC-V

LO-DIS RUGGED



LM16HC-V

LO-DIS RUGGED

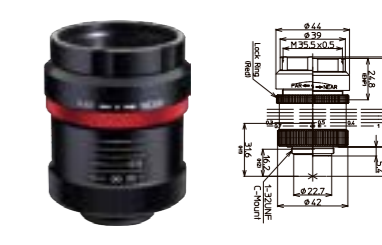

Model	LM8HC-V	LM12HC-V	LM16HC-V
Focal Length (mm)	8	12.5	16
Image Size (mm)	12.8×9.6 (Φ16)	12.8×9.6 (Φ16)	12.8×9.6 (Φ16)
Iris Range (F-Stop)	F1.4 / F2.8 / F4 / F8	F1.4 / F2.8 / F4 / F8	F1.4 / F2.8 / F4 / F8
Focusing Range (m)	0.1~∞	0.3~∞	0.3~∞
Control	Iris: - Focus: Manual	Iris: - Focus: Manual	Iris: - Focus: Manual
Shooting Range at M.O.D. (mm)	196.0 (H) × 143.0 (V)	330.6 (H) × 243.5 (V)	251.5 (H) × 186.2 (V)
Angle of View (Degrees)	1" 79.7 × 63.0 2/3" 58.3 × 44.7 1/1.8" 48.5 × 36.9	1" 55.6 × 42.5 2/3" 39.1 × 29.5 1/1.8" 32.1 × 24.2	1" 44.3 × 33.6 2/3" 30.8 × 23.2 1/1.8" 25.3 × 19.0
Resolution (Center, Corner)	100lp/mm, 80lp/mm	100lp/mm, 80lp/mm	100lp/mm, 80lp/mm
TV Distortion (%)	-1.2	-1.58	-1.0
Back Focus in Air (mm)	11.2	12.6	12.6
Mount	C-mount	C-mount	C-mount
Filter Thread (mm)	M55×P0.75	M35.5×P0.5	M35.5×P0.5
Size (mm)	φ58×58 (Min.) / φ58×58.6 (Max.)	φ44×51.5 (Min.) / φ44×52 (Max.)	φ44×53 (Min.) / φ44×53.85 (Max.)
Weight (g)	183	130	120
Temperature Range	-10°C~+50°C	-10°C~+50°C	-10°C~+50°C

LM25HC-V

LO-DIS RUGGED



LM35HC-V

LO-DIS RUGGED



LM50HC-V

LO-DIS RUGGED

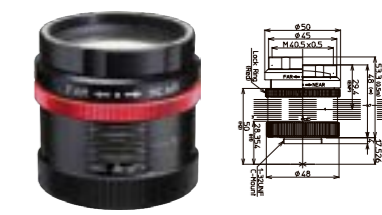

Model	LM25HC-V	LM35HC-V	LM50HC-V
Focal Length (mm)	25	35	50
Image Size (mm)	12.8×9.6 (Φ16)	12.8×9.6 (Φ16)	12.8×9.6 (Φ16)
Iris Range (F-Stop)	F1.4 / F2.8 / F4 / F8	F1.4 / F2.8 / F4 / F8	F1.4 / F2.8 / F4 / F8
Focusing Range (m)	0.3~∞	0.3~∞	0.5~∞
Control	Iris: - Focus: Manual	Iris: - Focus: Manual	Iris: - Focus: Manual
Shooting Range at M.O.D. (mm)	160.7 (H) × 119.2 (V)	110.1 (H) × 82.0 (V)	121.8 (H) × 91.3 (V)
Angle of View (Degrees)	1" 29.3 × 22.0 2/3" 20.2 × 15.1 1/1.8" 16.5 × 12.4	1" 20.9 × 15.8 2/3" 14.4 × 10.8 1/1.8" 11.8 × 8.8	1" 14.5 × 10.8 2/3" 10.0 × 7.5 1/1.8" 8.2 × 6.2
Resolution (Center, Corner)	100lp/mm, 80lp/mm	100lp/mm, 80lp/mm	100lp/mm, 80lp/mm
TV Distortion (%)	-1.0	-0.5	0.05
Back Focus in Air (mm)	16.5	16.8	14.8
Mount	C-mount	C-mount	C-mount
Filter Thread (mm)	M35.5×P0.5	M35.5×P0.5	M40.5×P0.5
Size (mm)	φ44×43 (Min.) / φ44×45.04 (Max.)	φ46×44.1 (Min.) / φ46×48.2 (Max.)	φ50×48 (Min.) / φ50×53.3 (Max.)
Weight (g)	104	133	170
Temperature Range	-10°C~+50°C	-10°C~+50°C	-10°C~+50°C

JCM-V Lens Series

2/3" | RUGGEDIZED 2 MEGAPIXEL

Model	Format Size (Inch)								
	4/3	1.2	1.1	1	1/1.2	2/3	1/1.8	1/2	1/3
LM5JCM-V	●	●	●	●	●	●	●	●	●
LM8JCM-V	●	●	●	●	●	●	●	●	●
LM12JCM-V	●	●	●	●	●	●	●	●	●
LM16JCM-V	●	●	●	●	●	●	●	●	●
LM25JCM-V	●	●	●	●	●	●	●	●	●
LM35JCM-V	●	●	●	●	●	●	●	●	●
LM50JCM-V	●	●	●	●	●	●	●	●	●

● Compatible ◇ Suitable * Incompatible

- 2/3" format size (φ11mm) with 2MP resolution.
- Patented mechanical design, engineered for superior vibration and impact resistance.
- Fixed, interchangeable aperture plates are adopted for added flexibility.
- A two-way reversible nut is used for precise focus adjustment.
- Applying adhesive to the lens barrel and elements significantly enhances vibration and shock resistance.



LM5JCM-V

LO-DIS XD RUGGED

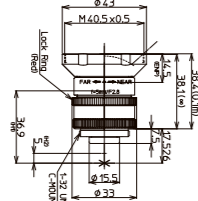

Model		LM5JCM-V
Focal Length (mm)		5
Image Size (mm)		8.8×6.6 (φ11)
Iris Range (F-Stop)		F2.8 / F4 / F5.6 / F8
Focusing Range (m)		0.1~∞
Control		Iris Focus
Shooting Range at M.O.D. (mm)		200.8 (H) × 150.8 (V)
Angle of View (Degrees)		2/3" 82.4 × 66.9 1/1.8" 71.7 × 57.1 1/2" 65.2 × 51.3
Resolution (Center, Corner)		100lp/mm, 80lp/mm
TV Distortion (%)		0.5
Back Focus in Air (mm)		10.0
Mount		C-mount
Filter Thread (mm)		M40.5×P0.5
Size (mm)		φ43×38.1 (Min.) / φ43×38.1 (Max.)
Weight (g)		73
Temperature Range		-10°C~+50°C

LM8JCM-V

LO-DIS XD RUGGED

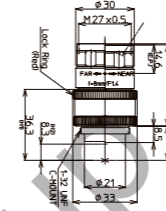

LM12JCM-V

LO-DIS XD RUGGED

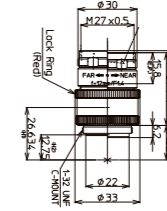

LM16JCM-V

LO-DIS RUGGED

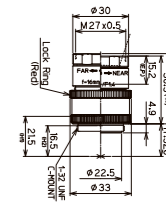

Model		LM8JCM-V	LM12JCM-V	LM16JCM-V
Focal Length (mm)		8	12	16
Image Size (mm)		8.8×6.6 (φ11)	8.8×6.6 (φ11)	8.8×6.6 (φ11)
Iris Range (F-Stop)		F1.4 / F4 / F8 / F16	F1.4 / F4 / F8 / F16	F1.4 / F4 / F8 / F16
Focusing Range (m)		0.1~∞	0.15~∞	0.2~∞
Control		Iris Focus	Iris Focus	Iris Focus
Shooting Range at M.O.D. (mm)		120.3 (H) × 90.0 (V)	110.0 (H) × 82.5 (V)	112.8 (H) × 84.4 (V)
Angle of View (Degrees)		2/3" 56.5 × 43.9 1/1.8" 47.4 × 36.3 1/2" 42.6 × 32.5	38.3 × 29.1 31.7 × 24.0 28.3 × 21.4	30.0 × 22.7 24.7 × 18.6 21.8 × 16.4
Resolution (Center, Corner)		100lp/mm, 80lp/mm	100lp/mm, 80lp/mm	100lp/mm, 80lp/mm
TV Distortion (%)		-0.6	-0.07	-0.05
Back Focus in Air (mm)		9.74	11.7	13.1
Mount		C-mount	C-mount	C-mount
Filter Thread (mm)		M27×P0.5	M27×P0.5	M27×P0.5
Size (mm)		φ33×41.6 (Min.) / φ33×42.2 (Max.)	φ33×37 (Min.) / φ33×38.1 (Max.)	φ33×36.5 (Min.) / φ33×37.8 (Max.)
Weight (g)		88	75	76.5
Temperature Range		-10°C~+50°C	-10°C~+50°C	-10°C~+50°C

LM25JCM-V

LO-DIS RUGGED

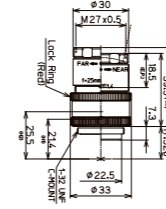

LM35JCM-V

LO-DIS RUGGED

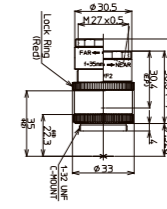

LM50JCM-V

LO-DIS RUGGED

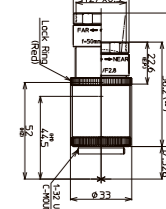

Model		LM25JCM-V	LM35JCM-V	LM50JCM-V
Focal Length (mm)		25	35	50
Image Size (mm)		8.8×6.6 (φ11)	8.8×6.6 (φ11)	8.8×6.6 (φ11)
Iris Range (F-Stop)		F1.4 / F4 / F8 / F16	F2 / F4 / F8 / F16	F2.8 / F4 / F8 / F16
Focusing Range (m)		0.2~∞	0.2~∞	0.2~∞
Control		Iris Focus	Iris Focus	Iris Focus
Shooting Range at M.O.D. (mm)		71.1 (H) × 53.3 (V)	47.9 (H) × 35.8 (V)	29.3 (H) × 21.9 (V)
Angle of View (Degrees)		2/3" 19.6 × 14.8 1/1.8" 16.1 × 12.1 1/2" 14.0 × 10.5	14.4 × 10.8 11.8 × 8.8 10.5 × 7.9	9.6 × 7.2 7.9 × 5.9 7.0 × 5.2
Resolution (Center, Corner)		100lp/mm, 80lp/mm	100lp/mm, 80lp/mm	100lp/mm, 80lp/mm
TV Distortion (%)		-0.04	-0.2	-0.03
Back Focus in Air (mm)		11.7	20.1	35.5
Mount		C-mount	C-mount	C-mount
Filter Thread (mm)		M27×P0.5	M27×P0.5	M27×P0.5
Size (mm)		φ33×39.5 (Min.) / φ33×42.6 (Max.)	φ33×38.8 (Min.) / φ33×45.3 (Max.)	φ33×56.2 (Min.) / φ33×71.8 (Max.)
Weight (g)		83	72.5	85
Temperature Range		-10°C~+50°C	-10°C~+50°C	-10°C~+50°C

Supported Camera Series KC48GC4 / KC130GC4 / KC200GC4 / KC300GC4 P.7-8 KC130XC2 / KC300XC3 P.10 KC48GC3 / KC130GC3 / KC200GC3 / KC300GC3 P.12

NCM-WP/JCM-WP Lens Series

1/1.8" | RUGGEDIZED WATER AND DUST RESISTANCE 2 MEGAPIXEL

2/3" | RUGGEDIZED WATER AND DUST RESISTANCE 2 MEGAPIXEL

Model	Format Size (Inch)								
	4/3	1.2	1.1	1	1/1.2	2/3	1/1.8	1/2	1/3
LM3NCM-WP	-	-	-	-	-	●	●	●	●
LM5JCM-WP	-	-	-	-	-	●	●	●	●
LM8JCM-WP	-	-	-	-	-	●	●	●	●
LM12JCM-WP	-	-	-	-	-	●	●	●	●
LM16JCM-WP	-	-	-	-	-	●	●	●	●
LM25JCM-WP	-	-	-	-	-	●	●	●	●
LM35JCM-WP	-	-	-	-	-	●	●	●	●
LM50JCM-WP	-	-	-	-	-	●	●	●	●

● Compatible ◇ Suitable * Incompatible

- Patented mechanical design, engineered for superior vibration and impact resistance.
- Offers exceptional water resistant and dust resistant protection.
- Special coatings enhance water repellency and cleaning efficiency of the front lens surface.
- Fixed, interchangeable aperture plates are adopted for added flexibility.
- A two-way reversible nut is used for precise focus adjustment.
- Applying adhesive to the lens barrel and elements significantly enhances vibration and shock resistance.



LM8JCM-WP

LO-DIS XD RUGGED WATER DUST



LM12JCM-WP

LO-DIS XD RUGGED WATER DUST

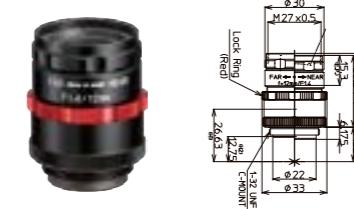

LM16JCM-WP

LO-DIS RUGGED WATER DUST

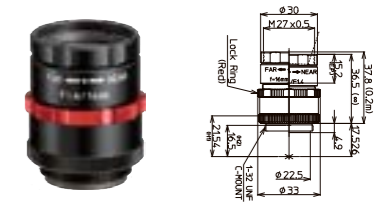

Model	LM8JCM-WP	LM12JCM-WP	LM16JCM-WP
Focal Length (mm)	8	12	16
Image Size (mm)	8.8×6.6 (Φ11)	8.8×6.6 (Φ11)	8.8×6.6 (Φ11)
Iris Range (F-Stop)	F1.4 / F4 / F8 / F16	F1.4 / F4 / F8 / F16	F1.4 / F4 / F8 / F16
Focusing Range (m)	0.1~∞	0.15~∞	0.2~∞
Control	Iris	-	-
Focus	Manual	Manual	Manual
Shooting Range at M.O.D. (mm)	120.3 (H) × 90.0 (V)	110.0 (H) × 82.5 (V)	112.8 (H) × 84.4 (V)
Angle of View (Degrees)	2/3" 56.5×43.9 1/1.8" 47.4×36.3 1/2" 42.6×32.5	38.3×29.1 31.7×24.0 28.3×21.4	30.0×22.7 24.7×18.6 21.8×16.4
Resolution (Center, Corner)	100lp/mm, 80lp/mm	100lp/mm, 80lp/mm	100lp/mm, 80lp/mm
TV Distortion (%)	-0.6	-0.07	-0.05
Back Focus in Air (mm)	9.74	11.7	13.1
Mount	C-mount	C-mount	C-mount
Filter Thread (mm)	M27×P0.5	M27×P0.5	M27×P0.5
Size (mm)	φ33×41.6 (Min.) / φ33×42.2 (Max.)	φ33×36.5 (Min.) / φ33×37.5 (Max.)	φ33×36.5 (Min.) / φ33×37.8 (Max.)
Weight (g)	85	75	75
Temperature Range	-10°C~+50°C	-10°C~+50°C	-10°C~+50°C

LM3NCM-WP

LO-DIS RUGGED WATER DUST

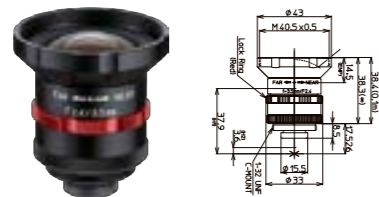

LM5JCM-WP

LO-DIS XD RUGGED WATER DUST

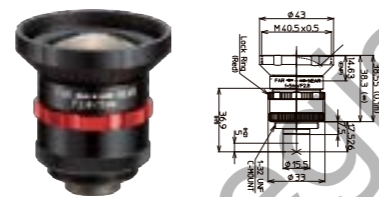

Model	LM3NCM-WP	LM5JCM-WP
Focal Length (mm)	3.5	5
Image Size (mm)	7.2×5.4 (Φ9)	8.8×6.6 (Φ11)
Iris Range (F-Stop)	F2.4 / F4 / F5.6 / F8	F2.8 / F4 / F5.6 / F8
Focusing Range (m)	0.1~∞	0.1~∞
Control	Iris	-
Focus	Manual	Manual
Shooting Range at M.O.D. (mm)	226.3 (H) × 171.4 (V)	200.8 (H) × 150.8 (V)
Angle of View (Degrees)	2/3" - 1/1.8" 89.0×73.8 1/2" 82.4×66.9	82.4×66.9 71.7×57.1 65.2×51.3
Resolution (Center, Corner)	100lp/mm, 80lp/mm	100lp/mm, 80lp/mm
TV Distortion (%)	0.4	0.5
Back Focus in Air (mm)	10.0	10.2
Mount	C-mount	C-mount
Filter Thread (mm)	M40.5×P0.5	M40.5×P0.5
Size (mm)	φ43×38.3 (Min.) / φ43×38.4 (Max.)	φ43×38.3 (Min.) / φ43×38.55 (Max.)
Weight (g)	80	75
Temperature Range	-10°C~+50°C	-10°C~+50°C

LM25JCM-WP

LO-DIS RUGGED WATER DUST



LM35JCM-WP

LO-DIS RUGGED WATER DUST

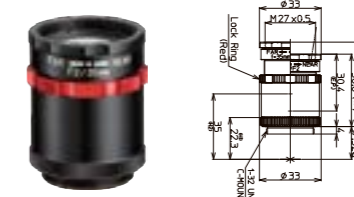

LM50JCM-WP

LO-DIS RUGGED WATER DUST

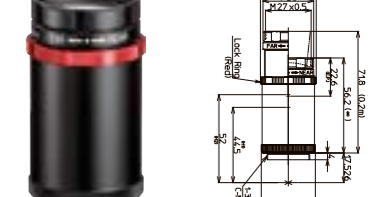

Model	LM25JCM-WP	LM35JCM-WP	LM50JCM-WP
Focal Length (mm)	25	35	50
Image Size (mm)	8.8×6.6 (Φ11)	8.8×6.6 (Φ11)	8.8×6.6 (Φ11)
Iris Range (F-Stop)	F1.4 / F4 / F8 / F16	F2 / F4 / F8 / F16	F2.8 / F4 / F8 / F16
Focusing Range (m)	0.2~∞	0.2~∞	0.2~∞
Control	Iris	-	-
Focus	Manual	Manual	Manual
Shooting Range at M.O.D. (mm)	71.1 (H) × 53.3 (V)	47.9 (H) × 35.8 (V)	29.3 (H) × 21.9 (V)
Angle of View (Degrees)	2/3" 19.6×14.8 1/1.8" 16.1×12.1 1/2" 14.0×10.5	14.4×10.8 11.8×8.8 10.5×7.9	9.6×7.2 7.9×5.9 7.0×5.2
Resolution (Center, Corner)	100lp/mm, 80lp/mm	100lp/mm, 80lp/mm	100lp/mm, 80lp/mm
TV Distortion (%)	-0.04	-0.2	-0.03
Back Focus in Air (mm)	11.7	19.9	35.4
Mount	C-mount	C-mount	C-mount
Filter Thread (mm)	M27×P0.5	M27×P0.5	M27×P0.5
Size (mm)	φ33×39.7 (Min.) / φ33×42.8 (Max.)	φ33×38.8 (Min.) / φ33×45.3 (Max.)	φ33×56.2 (Min.) / φ33×71.8 (Max.)
Weight (g)	83	65	85
Temperature Range	-10°C~+50°C	-10°C~+50°C	-10°C~+50°C

Supported Camera Series KC48GC4 / KC130GC4 / KC200GC4 / KC300GC4 P.7-8 KC130XC2 / KC300XC3 P.10 KC48GC3 / KC130GC3 / KC200GC3 / KC300GC3 P.12

EC-IR Lens Series

1.2" | IR-CORRECTED (VIS-NIR) 28 MEGAPIXEL 2.5 μm

Model	Format Size (Inch)								
	4/3	1.2	1.1	1	1/1.2	2/3	1/1.8	1/2	1/3
LM16EC-IR	●	●	●	●	●	●	●	●	●
LM25EC-IR	●	●	●	●	●	●	●	●	●
LM35EC-IR	●	●	●	●	●	●	●	●	●
LM50EC-IR	●	●	●	●	●	●	●	●	●

● Compatible ◊ Suitable * Incompatible

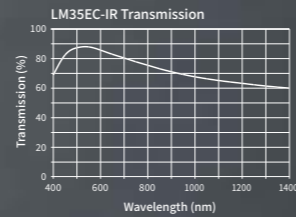

*In the case of LM35EC-IR

- Compatible with format sizes up to 1.2".
- Capable of resolving pixel sizes as small as 2.5μm.
- Supports a wide range of high-resolution sensors, including the IMX530 / IMX540 (1.2" 24MP) and IMX183 (1" 20MP).
- IR-corrected design eliminates focus shift when transitioning between visible and near-infrared (NIR) wavelengths.
- Features fixed, interchangeable aperture plates.
- A two-way reversible nut is used for precise focus adjustment.
- The series includes four models with focal lengths of 16mm, 25mm, 35mm, and 50mm.



Fixed Iris

Instead of standard iris blades, interchangeable aperture plates are used to set the F-Stop. With F2.4 preinstalled in the lens, the F-Stop can be adjusted to F2.8, F4, F5.6, or F8 using four additional aperture plates included.



* When using the LM16EC-IR with a working distance of 0.5m to 1m, remove the "Far" specific spacer and use it as the "Near" type.

IR-Corrected Design Eliminates Focus Shift

Standard Lens Designed for Visible Light



Visible Light

Near Infrared Light (NIR)

IR-Corrected Lens



Visible Light

Near Infrared Light (NIR)

LM16EC-IR

IR XD LO-DIS



LM25EC-IR

IR XD LO-DIS



Model	LM16EC-IR	LM25EC-IR
Focal Length (mm)	16	25
Image Size (mm)	15.4mm×11.5mm (φ19.2)	15.4mm×11.5mm (φ19.2)
Iris Range (F-Stop)	F2.4 / F2.8 / F4 / F5.6 / F8	F2.4 / F2.8 / F4 / F5.6 / F8
Focusing Range (m)	0.5~∞	0.5~∞
Control	Iris	-
Focus	Manual	Manual
Shooting Range at M.O.D. (mm)	501 (H) × 371 (V)	315 (H) × 233 (V)
Angle of View (Degrees)	1.2" : 52.4×40.0 1.1" : 48.4×37.0 1" : 44.3×33.7	34.9×26.1 32.0×24.1 29.1×21.9
Resolution (Center, Corner)	200lp/mm, 100lp/mm	200lp/mm, 100lp/mm
TV Distortion (%)	-0.6	-1.00
Back Focus in Air (mm)	19.57	15.6
Mount	C-mount	C-mount
Filter Thread (mm)	M34×0.5	M34×0.5
Size (mm)	Φ36.0×64.3 (Min.) / Φ36.0×64.8 (Max.)	Φ36.0×67.2 (Min.) / Φ36.0×68.4 (Max.)
Weight (g)	95	90
Temperature Range	-10°C~+50°C	-10°C~+50°C

LM35EC-IR

IR XD LO-DIS



LM50EC-IR

IR XD LO-DIS

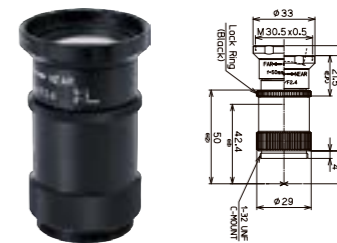

Model	LM35EC-IR	LM50EC-IR
Focal Length (mm)	35	50
Image Size (mm)	15.4mm×11.5mm (φ19.2)	15.4mm×11.5mm (φ19.2)
Iris Range (F-Stop)	F2.4 / F2.8 / F4 / F5.6 / F8	F2.4 / F2.8 / F4 / F5.6 / F8
Focusing Range (m)	0.5~∞	0.5~∞
Control	Iris	-
Focus	Manual	Manual
Shooting Range at M.O.D. (mm)	222 (H) × 165 (V)	147 (H) × 109 (V)
Angle of View (Degrees)	1.2" : 25.0×18.7 1.1" : 22.9×17.3 1" : 20.8×15.7	17.5×13.1 16.1×12.1 14.6×11.0
Resolution (Center, Corner)	200lp/mm, 100lp/mm	200lp/mm, 100lp/mm
TV Distortion (%)	-0.3	0.02
Back Focus in Air (mm)	14.72	17.94
Mount	C-mount	C-mount
Filter Thread (mm)	M30.5×0.5	M30.5×0.5
Size (mm)	Φ33.0×50.4 (Min.) / Φ33.0×52.9 (Max.)	Φ33.0×50.8 (Min.) / Φ33.0×56.1 (Max.)
Weight (g)	80	70
Temperature Range	-10°C~+50°C	-10°C~+50°C

Supported Camera Series KC1200GC4 P.8 KC1200GC3 / KC1600GC3 / KC2000GC3 / KC2400GC3 P.13

HC-VIS-SW Lens Series

1" | IR-CORRECTED (VIS-SW) 12 MEGAPIXEL 3.1 μm

Model	Format Size (Inch)								
	4/3	1.2	1.1	1	1/1.2	2/3	1/1.8	1/2	1/3
LM8HC-VIS-SW	●	●	●	●	●	●	●	●	●
LM12HC-VIS-SW	●	●	●	●	●	●	●	●	●
LM16HC-VIS-SW	●	●	●	●	●	●	●	●	●
LM25HC-VIS-SW	◇	◇	◇	◇	◇	◇	◇	◇	◇
LM35HC-VIS-SW	◇	◇	◇	◇	◇	◇	◇	◇	◇
LM50HC-VIS-SW	◇	◇	◇	◇	◇	◇	◇	◇	◇

● Compatible ◇ Suitable * Incompatible

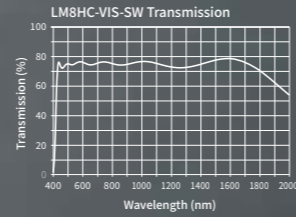

- 1" format size with 12MP resolution (3.1μm).
- IR-corrected design eliminates focus shift across 450nm to 2,000nm wavelength range.
- Special extra-low dispersion (XD) glass is utilized to dramatically reduce chromatic aberration, delivering exceptional image clarity and color accuracy.
- Kowa's Floating Mechanism design is incorporated into all HC-VIS-SW series models to effectively minimize aberrations from close object distances to infinity.
- Low distortion ensures precise identification of materials or defects.
- Features Kowa's EX Wide-Band Multi-Coatings, which enhance lens performance across a broad spectrum of wavelengths.



LM8HC-VIS-SW

EX-WBMC LO-DIS FLOAT XD

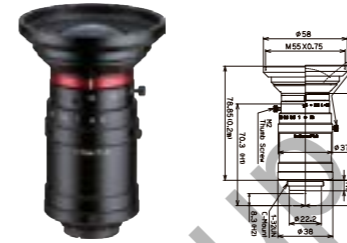

LM12HC-VIS-SW

EX-WBMC LO-DIS FLOAT XD



LM16HC-VIS-SW

EX-WBMC LO-DIS FLOAT XD

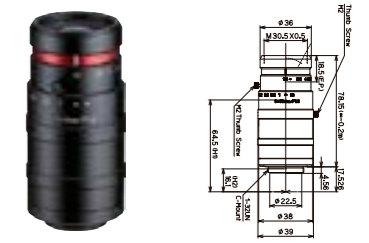

Model	LM8HC-VIS-SW	LM12HC-VIS-SW	LM16HC-VIS-SW
Focal Length (mm)	8	12	16
Image Size (mm)	12.8×9.6 (Φ16)	12.8×9.6 (Φ16)	12.8×9.6 (Φ16)
Iris Range (F-Stop)	F1.8~F16	F1.8~F16	F1.8~F16
Focusing Range (m)	0.2~∞	0.2~∞	0.2~∞
Control	Iris Focus	Manual Manual	Manual Manual
Shooting Range at M.O.D. (mm)	387.0 (H) × 272.0 (V)	237.0 (H) × 175.0 (V)	174.0 (H) × 129.0 (V)
Angle of View (Degrees)	1" 81.3×63.5 2/3" 58.7×44.8 1/1.8" 48.6×36.9	58.0×44.5 41.0×31.1 33.8×25.5	44.2×33.6 31.0×23.3 25.4×19.1
Resolution (Center, Corner)	160lp/mm, 80lp/mm	160lp/mm, 100lp/mm	160lp/mm, 100lp/mm
TV Distortion (%)	-3.1	-1.6	-0.81
Back Focus in Air (mm)	11.1	11.1	15.0
Mount	C-mount	C-mount	C-mount
Filter Thread (mm)	M55×P0.75	M34×P0.5	M30.5×P0.5
Size (mm)	φ58×78.85 (Min.) / φ58×79.5 (Max.)	φ38.5×73.5	φ39×78.15
Weight (g)	210	175	190
Temperature Range	-10°C~+50°C	-10°C~+50°C	-10°C~+50°C

LM25HC-VIS-SW

EX-WBMC LO-DIS FLOAT XD



LM35HC-VIS-SW

EX-WBMC LO-DIS FLOAT XD

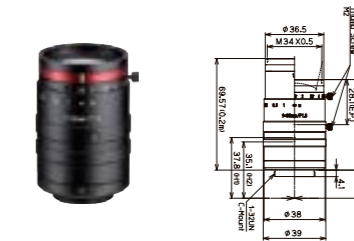

LM50HC-VIS-SW

EX-WBMC LO-DIS FLOAT XD



Model	LM25HC-VIS-SW	LM35HC-VIS-SW	LM50HC-VIS-SW
Focal Length (mm)	25	35	50
Image Size (mm)	12.8×9.6 (Φ16)	12.8×9.6 (Φ16)	12.8×9.6 (Φ16)
Iris Range (F-Stop)	F1.8~F16	F1.8~F16	F2.5~F16
Focusing Range (m)	0.2~∞	0.2~∞	0.5~∞
Control	Iris Focus	Manual Manual	Manual Manual
Shooting Range at M.O.D. (mm)	109.0 (H) × 81.0 (V)	68.0 (H) × 51.0 (V)	127.0 (H) × 95.0 (V)
Angle of View (Degrees)	1" 29.2×22.0 2/3" 20.2×15.0 1/1.8" 16.5×12.3	20.4×15.4 14.0×10.6 11.5×8.6	14.6×11.0 10.0×7.6 8.2×6.2
Resolution (Center, Corner)	160lp/mm, 100lp/mm	160lp/mm, 100lp/mm	160lp/mm, 100lp/mm
TV Distortion (%)	-0.97	-0.37	-0.11
Back Focus in Air (mm)	24.5	16.4	34.9
Mount	C-mount	C-mount	C-mount
Filter Thread (mm)	M27×P0.5	M34×P0.5	M30.5×P0.5
Size (mm)	φ39×65.5 (Min.) / φ39×69.7 (Max.)	φ39×56.42 (Min.) / φ39×69.57 (Max.)	φ39.5×71 (Min.) / φ39.5×76.6 (Max.)
Weight (g)	160	150	155
Temperature Range	-10°C~+50°C	-10°C~+50°C	-10°C~+50°C

Near Infrared (NIR) Corrected Lens

A key characteristic of near infrared (NIR) corrected lenses is their ability to capture clear images while maintaining sharp focus, even when wavelengths transition between visible light and NIR light. Unlike standard lenses that experience focus shift due to refractive index variations caused by wavelength changes, Kowa's NIR corrected lenses are engineered with specially manufactured extra low dispersion (XD) glass. This optical technology ensures exceptional image quality and precise focus across a broad wavelength range, providing reliable performance for high-precision imaging applications.

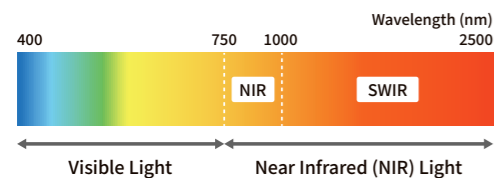

Example of Focus Shift

* Focuses at 1,650nm

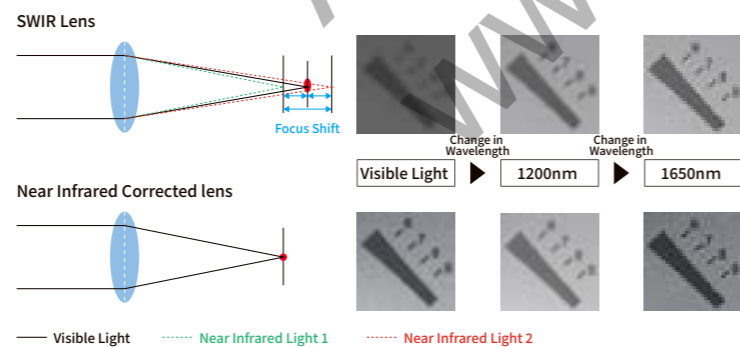

HC-SW Lens Series

1" | SWIR 1MEGAPIXEL+

Model	Format Size (Inch)								
	4/3	1.2	1.1	1	1/1.2	2/3	1/1.8	1/2	1/3
LM6HC-SW	-	-	-	●	●	●	●	●	●
LM8HC-SW	-	-	-	●	●	●	●	●	●
LM12HC-SW	-	-	◇	●	●	●	●	●	●
LM16HC-SW	-	-	◇	●	●	●	●	●	●
LM25HC-SW	-	-	◇	●	●	●	●	●	●
LM35HC-SW	-	-	◇	●	●	●	●	●	●
LM50HC-SW	-	-	◇	●	●	●	●	●	●

● Compatible ◇ Suitable * Incompatible

- The HC-SW lens series, built with a 1" format size, are optimized with specialized SWIR coatings that delivers outstanding transmission across the short-wavelength infrared (SWIR) range. Kowa's advanced coating technology ensures superior image clarity, precision, and reliability, making these lenses the perfect choice for high-accuracy imaging applications where performance in the SWIR spectrum is essential.

- The recent addition of a wide-angle 6mm model expands the lineup, offering greater versatility to address a broad range of imaging applications.

- A well-rounded lineup of 7 models with focal lengths ranging from 6mm to 50mm.

- Offering exceptional value, this cost-effective lens series is designed to produce consistent and accurate results in a variety of applications.

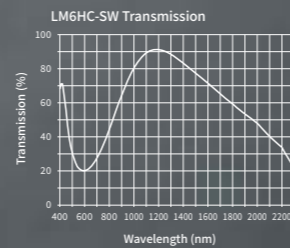

LM6HC-SW

SWIR LO-DIS

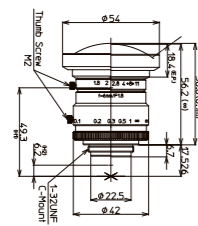

Model		LM6HC-SW
Focal Length (mm)		6
Image Size (mm)		12.8×9.6 (Φ16)
Iris Range (F-Stop)		F1.8~F11
Focusing Range (m)		0.1~∞
Control		Iris: Manual Focus: Manual
Shooting Range at M.O.D. (mm)		267.4 (H) × 196.3 (V)
Angle of View (Degrees)		1" : 96.8 × 79.4 2/3" : 74.1 × 58.0 1/1.8" : 62.6 × 48.2
Resolution (Center, Corner)		100lp/mm, 80lp/mm
TV Distortion (%)		-0.2
Back Focus in Air (mm)		11.1
Mount		C-mount
Filter Thread (mm)		-
Size (mm)		φ54×56.2 (Min.) / φ54×56.6 (Max.)
Weight (g)		215
Temperature Range		-10°C~+50°C

LM8HC-SW

SWIR LO-DIS

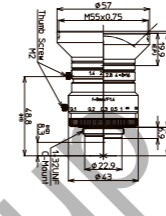

LM12HC-SW

SWIR LO-DIS

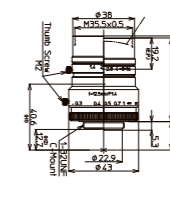

LM16HC-SW

SWIR LO-DIS

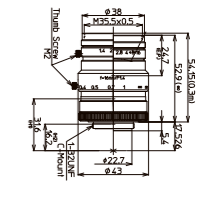

Model	LM8HC-SW	LM12HC-SW	LM16HC-SW	
Focal Length (mm)	8	12.5	16	
Image Size (mm)	12.8×9.6 (Φ16)	12.8×9.6 (Φ16)	12.8×9.6 (Φ16)	
Iris Range (F-Stop)	F1.4~F16	F1.4~F16	F1.4~F16	
Focusing Range (m)	0.1~∞	0.3~∞	0.3~∞	
Control		Manual		
Focus		Manual		
Shooting Range at M.O.D. (mm)		196.0 (H) × 143.2 (V)	330.6 (H) × 243.5 (V)	251.5 (H) × 186.2 (V)
Angle of View (Degrees)		1" : 79.4 × 63.0 2/3" : 58.3 × 44.7 1/1.8" : 48.5 × 36.9	1" : 55.6 × 42.5 2/3" : 39.1 × 29.5 1/1.8" : 32.1 × 24.2	1" : 44.3 × 33.6 2/3" : 30.8 × 23.2 1/1.8" : 25.3 × 19.0
Resolution (Center, Corner)		100lp/mm, 80lp/mm	100lp/mm, 80lp/mm	100lp/mm, 80lp/mm
TV Distortion (%)		-1.2	-1.58	-1.0
Back Focus in Air (mm)		11.2	12.6	12.6
Mount		C-mount		
Filter Thread (mm)		M55×P0.75	M35.5×P0.5	M35.5×P0.5
Size (mm)		φ57×58 (Min.) / φ57×59.25 (Max.)	φ43×51.5 (Min.) / φ43×52.75 (Max.)	φ43×52.9 (Min.) / φ43×54.15 (Max.)
Weight (g)		205	160	150
Temperature Range		-10°C~+50°C	-10°C~+50°C	-10°C~+50°C

LM25HC-SW

SWIR LO-DIS

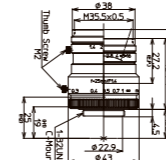

LM35HC-SW

SWIR LO-DIS

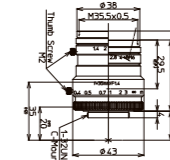

LM50HC-SW

SWIR LO-DIS

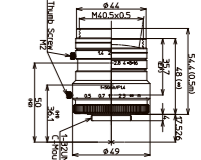

Model	LM25HC-SW	LM35HC-SW	LM50HC-SW	
Focal Length (mm)	25	35	50	
Image Size (mm)	12.8×9.6 (Φ16)	12.8×9.6 (Φ16)	12.8×9.6 (Φ16)	
Iris Range (F-Stop)	F1.4~F16	F1.4~F16	F1.4~F16	
Focusing Range (m)	0.3~∞	0.3~∞	0.5~∞	
Control		Manual		
Focus		Manual		
Shooting Range at M.O.D. (mm)		160.7 (H) × 119.2 (V)	110.1 (H) × 82.0 (V)	121.8 (H) × 91.3 (V)
Angle of View (Degrees)		1" : 29.3 × 22.0 2/3" : 20.2 × 15.1 1/1.8" : 16.5 × 12.4	1" : 20.9 × 15.8 2/3" : 14.4 × 10.8 1/1.8" : 11.8 × 8.8	1" : 14.5 × 10.8 2/3" : 10.0 × 7.5 1/1.8" : 8.2 × 6.2
Resolution (Center, Corner)		100lp/mm, 80lp/mm	100lp/mm, 80lp/mm	100lp/mm, 80lp/mm
TV Distortion (%)		-1.0	-0.5	0.05
Back Focus in Air (mm)		16.5	16.8	14.8
Mount		C-mount		
Filter Thread (mm)		M35.5×P0.5	M35.5×P0.5	M40.5×P0.5
Size (mm)		φ43×43 (Min.) / φ43×48.4 (Max.)	φ43×43 (Min.) / φ43×48.4 (Max.)	φ49×48 (Min.) / φ49×54.4 (Max.)
Weight (g)		135	135	210
Temperature Range		-10°C~+50°C	-10°C~+50°C	-10°C~+50°C

JC5M-IR Lens Series

2/3" | IR-CORRECTED (VIS-NIR) 5 MEGAPIXEL 3.45 μm

Model	Format Size (Inch)								
	4/3	1.2	1.1	1	1/1.2	2/3	1/1.8	1/2	1/3
LM16JC5M-IR	-	-	-	-	-	●	●	●	●
LM25JC5M-IR	-	-	-	-	◇	●	●	●	●
LM35JC5M-IR	-	-	-	-	◇	●	●	●	●

● Compatible ◇ Suitable * Incompatible

- 2/3" format size and 5MP resolution.
 - IR-Corrected design eliminates focus shift when transitioning between visible and near-infrared (NIR) wavelengths.
 - Suitable for a wide range of applications, from factory automation to intelligent traffic solutions (ITS).
 - Bright optical design with an F-Stop of F1.4 at maximum aperture.
- * The maximum aperture F-Stop for the LM35JC5M-IR model is F2.0.

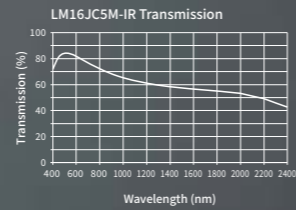

LM16JC5M-IR

IR LO-DIS XD



Model	LM16JC5M-IR
Focal Length (mm)	16
Image Size (mm)	8.8×6.6 (Φ11)
Iris Range (F-Stop)	F1.4~F16
Focusing Range (m)	0.3~∞
Control	Iris: Manual Focus: Manual
Shooting Range at M.O.D. (mm)	171.4 (H) × 127.4 (V)
Angle of View (Degrees)	2/3" : 30.9×23.2 1/1.8" : 25.4×19.0 1/2" : 22.6×16.9
Resolution (Center, Corner)	120lp/mm, 80lp/mm
TV Distortion (%)	-0.8
Back Focus in Air (mm)	14.7
Mount	C-mount
Filter Thread (mm)	M27×P0.5
Size (mm)	φ34×44.5 (Min.) / φ34×45.5 (Max.)
Weight (g)	100
Temperature Range	-10°C~+50°C

LM25JC5M-IR

IR LO-DIS XD



Model	LM25JC5M-IR
Focal Length (mm)	25
Image Size (mm)	8.8×6.6 (Φ11)
Iris Range (F-Stop)	F1.4~F16
Focusing Range (m)	0.3~∞
Control	Iris: Manual Focus: Manual
Shooting Range at M.O.D. (mm)	113.3 (H) × 84.5 (V)
Angle of View (Degrees)	2/3" : 20.1×15.1 1/1.8" : 16.5×12.4 1/2" : 14.6×11.0
Resolution (Center, Corner)	120lp/mm, 80lp/mm
TV Distortion (%)	-0.3
Back Focus in Air (mm)	12.0
Mount	C-mount
Filter Thread (mm)	M30.5×P0.5
Size (mm)	φ34×47 (Min.) / φ34×49.1 (Max.)
Weight (g)	110
Temperature Range	-10°C~+50°C

LM35JC5M-IR

IR LO-DIS XD



Model	LM35JC5M-IR
Focal Length (mm)	35
Image Size (mm)	8.8×6.6 (Φ11)
Iris Range (F-Stop)	F2.0~F22
Focusing Range (m)	0.3~∞
Control	Iris: Manual Focus: Manual
Shooting Range at M.O.D. (mm)	75.8 (H) × 56.6 (V)
Angle of View (Degrees)	2/3" : 13.9×10.5 1/1.8" : 11.4×8.3 1/2" : 10.2×7.6
Resolution (Center, Corner)	120lp/mm, 80lp/mm
TV Distortion (%)	-0.3
Back Focus in Air (mm)	19.2
Mount	C-mount
Filter Thread (mm)	M30.5×P0.5
Size (mm)	φ34×43 (Min.) / φ34×47.3 (Max.)
Weight (g)	100
Temperature Range	-10°C~+50°C

IR-Corrected Design Eliminates Focus Shift

Normal Lens for Use in Visible Light



Wavelength Change



Blurring Caused by Focus Shift

IR-Corrected Lens with No Focus Shift



Wavelength Change



Application Example



Wavelength Change



Wavelength Change



TC Lens Series

4/3" | TELECENTRIC 21 MEGAPIXEL 3.45 μm

Model	Format Size (Inch)								
	4/3	1.2	1.1	1	1/1.2	2/3	1/1.8	1/2	1/3
LM1119TC	●	●	●	●	●	●	●	●	●
LM1138TC	-	-	-	-	-	-	-	-	-
LM1120TC	-	-	-	-	-	-	-	-	-
LM1121TC	-	-	-	-	-	-	-	-	-
LM1122TC	-	-	-	-	-	-	-	-	-
LM1123TC	-	-	-	-	-	-	-	-	-
LM1125TC	-	-	-	-	-	-	-	-	-

● Compatible ◇ Suitable * Incompatible

4/3" 21MP Macro Zoom Telecentric Lens Series

- Telecentric lens with variable magnification.
- 21MP resolution.
- Can be used as a macro lens with a variable magnification between 0.5x and 1.0x.

4/3" 21MP Macro Telecentric Lens Series

- Telecentric lens with a fixed magnification.
- 21MP resolution.
- Can be used as a macro lens with a magnification of 2.0x (fixed).

2/3" 5MP+ Telecentric Lens Series

- Intuitive lens selection based on pixel size.
- Optical magnification range is fully adjustable.
- Optimized optical magnification for 5MP sensor resolution.
- Low distortion design of 0.02% or less.
- Ensures consistent high contrast from center to edge for optimal image clarity.



2/3" telecentric 5MP plus

LM1120TC

LO-DIS XD

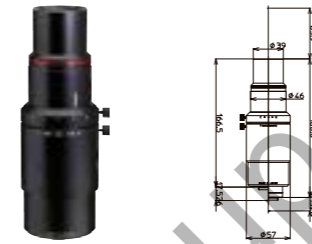

LM1121TC

LO-DIS XD



LM1122TC

LO-DIS XD

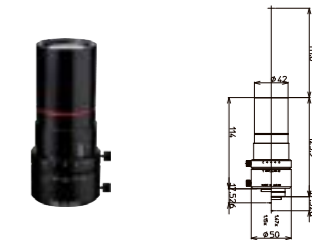

Model	LM1120TC			LM1121TC			LM1122TC		
	Magnification Range	3.45~4.4X			1.725~2.2X			1.15~1.47X	
Image Size (mm)	8.8×6.6 (Φ11)			8.8×6.6 (Φ11)			8.8×6.6 (Φ11)		
Shooting Magnification	3.45X	4.0X	4.4X	1.725X	2.0X	2.2X	1.15X	1.3X	1.47X
Objective N.A.	0.2	0.2	0.2	0.131	0.131	0.131	0.101	0.101	0.101
W.D.(mm)	65.9	65.9	65.9	114.8	111.4	109.4	111.6	111.6	111.6
Shooting Range (mm)	2/3"	2.6×1.9	2.2×1.7	2.0×1.5	5.1×3.8	4.4×3.3	4.0×3.0	7.6×5.7	6.6×5.0
	1/1.8"	2.1×1.6	1.8×1.4	1.6×1.2	4.2×3.1	3.6×2.7	3.3×2.4	6.3×4.7	5.5×4.1
	1/2"	1.9×1.4	1.6×1.2	1.5×1.1	3.7×2.8	3.2×2.4	2.9×2.2	5.6×4.2	4.9×3.7
TV Distortion (%)	0.015	0.003	-0.002	0.011	0.004	0.001	-0.015	-0.001	0.011
Back Focus in Air (mm)	17.1	24.5	30	55.8	67.7	76.3	18.7	23.6	29.8
Mount	C-mount			C-mount			C-mount		
Resolution	120lp/mm			120lp/mm			120lp/mm		
Size (mm)	Φ57×180.0			Φ48×147.5			Φ50×123.9		
Weight (g)	645			420			330		
Temperature Range	-10°C~+50°C			-10°C~+50°C			-10°C~+50°C		

Telecentric Optical Systems: Precision Imaging for Accurate Measurements

Telecentric optical systems are distinguished by their ability to maintain consistent magnification during focus adjustments, enabling direct imaging of objects from the front (see Fig. 1). This characteristic makes them particularly suitable for high-precision dimensional measurements, especially when exact positioning is required. In these systems, the chief ray, which is the central light ray from a point on the object entering the lens, runs parallel to the optical axis. By setting the aperture at the image-side focal point, the chief ray on the object side becomes parallel to the optical axis. Consequently, when the object's position shifts along the optical axis, the image may blur, but the magnification remains unchanged.

Fig. 1

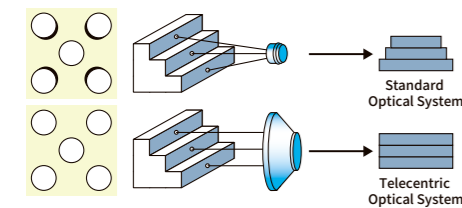
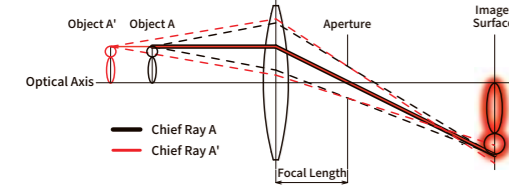

Fig. 2



Application Examples

- Surface inspection of silicon wafers.
- Reading in 2D codes.
- Inspection of dirt on prisms and glass circuit boards.
- Inspection of FPD image defects.
- Hole pitch measurement.

4/3" macro zoom 21MP

LM1119TC

LO-DIS XD

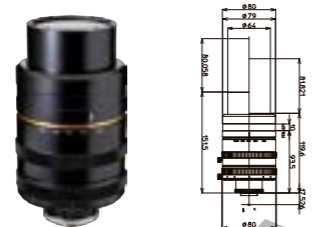

4/3" macro 21MP

LM1138TC

LO-DIS XD



Model	LM1119TC		LM1138TC
	Magnification Range	0.5~1.0X	
Image Size (mm)	18.4×13.8 (Φ23)		18.4×13.8 (Φ23)
Shooting Magnification	0.5X	1.0X	2.0X
Objective N.A.	0.05	0.1	0.2
W.D.(mm)	80	81.8	80.6
Shooting Range (mm)	4/3"	36.8×27.6	18.4×13.8
	1"	25.6×19.2	12.8×9.6
	2/3"	17.6×13.2	8.8×6.6
TV Distortion (%)	0.1	0.1	0.1
Back Focus in Air (mm)	14.7		15.0
Mount	C-mount		C-mount
Resolution	120lp/mm		120lp/mm
Size (mm)	Φ82×151.5		Φ64×151.0
Weight (g)	1000		830
Temperature Range	-10°C~+50°C		-10°C~+50°C

2/3" telecentric 5MP plus

LM1123TC

LO-DIS XD



LM1125TC

LO-DIS XD

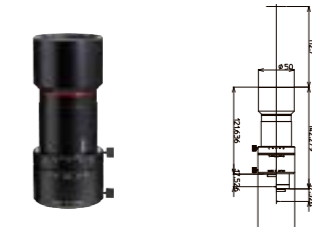

Model	LM1123TC			LM1125TC		
	Magnification Range	0.69~0.88X			0.346~0.44X	
Image Size (mm)	8.8×6.6 (Φ11)			8.8×6.6 (Φ11)		
Shooting Magnification	0.69X	0.8X	0.88X	0.346X	0.4X	0.44X
Objective N.A.	0.07	0.07	0.07	0.04	0.04	0.04
W.D.(mm)	111.0	111.0	111.0	112.7	112.7	112.7
Shooting Range (mm)	2/3"	12.7×9.6	11.0×8.2	10.0×7.5	25.4×19.1	22.0×16.5
	1/1.8"	10.4×7.8	9.0×6.7	8.2×6.1	20.9×15.7	18.1×13.6
	1/2"	9.3×7.0	8.0×6.0	7.3×5.5	18.6×13.9	16.1×12.1
TV Distortion (%)	-0.001	-0.009	0.005	0.02	-0.009	0.01
Back Focus in Air (mm)	34	28.8	25.3	17.6	17	16.5
Mount	C-mount			C-mount		
Resolution	120lp/mm			120lp/mm		
Size (mm)	Φ50×121.5			Φ51.5×142.3		
Weight (g)	290			420		
Temperature Range	-10°C~+50°C			-10°C~+50°C		

Varifocal Lens Series

1/1.8" | VARIFOCAL 1 MEGAPIXEL

1/2" | VARIFOCAL 1 MEGAPIXEL

Model	Format Size (Inch)								
	4/3	1.2	1.1	1	1/1.2	2/3	1/1.8	1/2	1/3
LMVZ4411	-	-	-	-	-	-	●	●	●
LMVZ990-IR	-	-	-	-	-	-	-	●	●

● Compatible ◇ Suitable * Incompatible

- Supports 1/1.8" and 1/2" format sizes.
- Adjustable angle of view to match application needs.
- Engineered for versatility and ideal for both security and factory automation (FA) applications.



NF Lens Series

1/3" | NF-MOUNT LENS 1 MEGAPIXEL+

Model	Format Size (Inch)								
	4/3	1.2	1.1	1	1/1.2	2/3	1/1.8	1/2	1/3
LM3NF	-	-	-	-	-	-	-	-	●
LM5NF	-	-	-	-	-	-	-	-	●
LM9NF	-	-	-	-	-	-	-	◇	●

● Compatible ◇ Suitable * Incompatible

- Developed as a high-performance optical solution for 1/3" megapixel NF-Mount cameras, these lenses deliver excellent image quality in a lightweight and compact form.
- Produces uniform brightness and resolution from the image center to the corners.
- Offers a significantly lighter design (30g) and a more compact form factor (φ21mm outer diameter)* compared to conventional C-Mount lenses.**

*LM3NF **LM3NF, LM5NF



LMVZ4411

LO-DIS

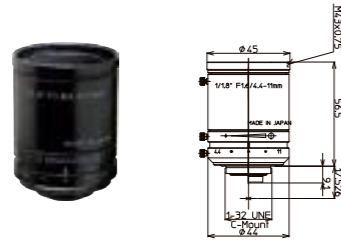

LMVZ990-IR

LO-DIS XD IR

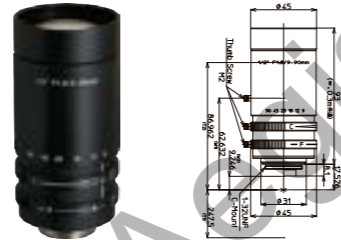

Model	LMVZ4411	LMVZ990-IR
Focal Length (mm)	4.4~11 (2.5×)	9~90 (10×)
Image Size (mm)	7.2×5.4 (Φ9)	6.4×4.8 (Φ8)
Iris Range (F-Stop)	F1.6~F16	F1.8~F16
Focusing Range (m)	0.3~∞	0.3~∞
Control	Iris: Manual Focus: Manual	Manual
Shooting Range at M.O.D. (mm)	W507.5×379.0 / T211.4×159.0	W252.7×182.5 / T94.4×70.8
Angle of View (Degrees)	1/1.8" W76.6×61.2 / T36.7×28.0 1/2" W70.1×55.5 / T32.9×25.0 1/3" W55.5×43.0 / T25.0×18.9	W41.1×30.3 / T4.2×3.1 W30.3×22.6 / T3.1×2.4
TV Distortion (%)	W-0.2 / T0.4	W-4.3 / T0.3
Back Focus in Air (mm)	W8.8 / T14.5	W15.4 / T11.7
Mount	C-mount	C-mount
Filter Thread (mm)	M43×P0.75	M43×P0.75
Size (mm)	Φ45×56.5	Φ45×93
Weight (g)	125	194
Temperature Range	-10°C~+50°C	-10°C~+50°C

LM3NF

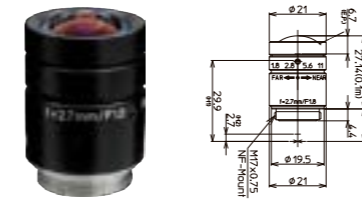

LM5NF

LO-DIS



LM9NF

LO-DIS



Model	LM3NF	LM5NF	LM9NF
Focal Length (mm)	2.7	4.5	9
Image Size (mm)	4.8×3.6 (Φ6)	4.8×3.6 (Φ6)	4.8×3.6 (Φ6)
Iris Range (F-Stop)	F1.8~F11	F1.8~F11	F1.8~F11
Focusing Range (m)	0.1~∞	0.1~∞	0.1~∞
Control	Iris: Manual Focus: Manual	Manual	Manual
Shooting Range at M.O.D. (mm)	262.7 (H) × 167.8 (V)	122.9 (H) × 89.9 (V)	58.1 (H) × 43.3 (V)
Angle of View (Degrees)	1/3" 102.3×76.7	59.2×45.0	30.2×22.8
Resolution (Center, Corner)	100lp/mm, 60lp/mm	100lp/mm, 60lp/mm	100lp/mm, 60lp/mm
TV Distortion (%)	-7.3	-2.8	-0.6
Back Focus in Air (mm)	7.8	8.1	8.6
Mount	NF-mount	NF-mount	NF-mount
Size (mm)	Φ21×27 (Min.) / Φ21×27.14 (Max.)	Φ21×31 (Min.) / Φ21×31.19 (Max.)	Φ22×34 (Min.) / Φ22×34.84 (Max.)
Weight (g)	30	35	40
Temperature Range	-10°C~+50°C	-10°C~+50°C	-10°C~+50°C

LF Lens Series

Φ46 | LINE SCAN 4K

Model	Format Size (Inch)							
	57.0	51.0	46.0	38.0	35.0	30.0	23.0	18.0
LM28LF	-	-	●	●	●	●	●	●
LM35LF	-	◇	●	●	●	●	●	●
LM50LF	-	-	◇	●	●	●	●	●

● Compatible ◇ Suitable * Incompatible

- Large image size of Φ46mm.
- Low distortion
- Close-range imaging is possible at working distances as short as 0.26 m, measured from the front lens tip to the object surface. Applicable only for the LM35LF and LM50LF models.
- Available in two mount types: Nikon F-Mount and TFL II-Mount



CLS Lens Series

Φ30 | LINE SCAN (3CMOS)

Model	Format Size (Inch)							
	57.0	51.0	46.0	38.0	35.0	30.0	23.0	18.0
LM28CLS	-	-	-	-	-	●	●	●
LM35CLS	-	-	-	-	-	◇	●	●
LM50CLS	-	-	-	-	-	-	◇	●

● Compatible ◇ Suitable * Incompatible

- Lenses designed for use with industrial line scan cameras featuring a three-sensor, three-dichroic prism configuration.
- Supports line sensor lengths up to 30mm.
- Engineered to take full advantage of the imaging precision of three-sensor, three-dichroic prism line scan systems.
- Compatible with Nikon F-Mount for direct use with existing systems.



LM28LF

LO-DIS XD



LM35LF

LO-DIS XD

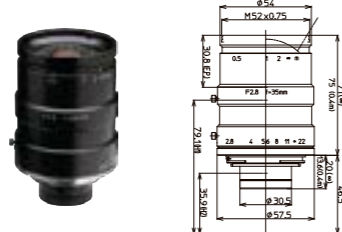

LM50LF

LO-DIS XD



LM28CLS

LO-DIS XD



LM35CLS

LO-DIS XD

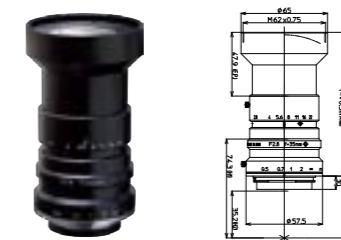

LM50CLS

LO-DIS XD



Model	LM28LF	LM28LF-48	LM35LF	LM35LF-48	LM50LF	LM50LF-48
Focal Length (mm)	28		35		50	
Image Size (mm)	36×24 (Φ46)		36×24 (Φ46)		36×24 (Φ46)	
Iris Range (F-Stop)	F2.8~F22		F2.8~F22		F2.8~F22	
Focusing Range (m)	0.5~∞		0.4~∞		0.4~∞	
Control	Iris Focus		Manual Manual		Manual Manual	
Shooting Range at M.O.D. (mm)	424.3×281.1		239.9×160.3		162.9×108.9	
Angle of View (Degrees)	Full size 4/3" 1"		64.6×45.8 35.8×27.2 25.3×19.1		53.7×37.2 28.9×21.8 20.3×15.3	
Resolution (Center, Corner)	160lp/mm, 63lp/mm		160lp/mm, 63lp/mm		160lp/mm, 63lp/mm	
TV Distortion (%)	-0.17		-0.15		-0.04	
Back Focus in Air (mm)	38.5	38.5	34.6	34.6	37.7	37.7
Flange Back in air (mm)	46.5	17.5	46.5	17.5	46.5	17.5
Mount	Nikon F-mount TFL-II mount		Nikon F-mount TFL-II mount		Nikon F-mount TFL-II mount	
Filter Thread (mm)	M72×P0.75		M52×P0.75		M52×P0.75	
Size (mm)	Φ75×98	Φ75×127	Φ57.5×71 (Min.) / Φ57.5×75 (Max.)	Φ55×100 (Min.) / Φ55×104 (Max.)	Φ57.5×77 (Min.) / Φ57.5×86.1 (Max.)	Φ57.5×106
Weight (g)	500		430		470	
Temperature Range	-10°C~+50°C		-10°C~+50°C		-10°C~+50°C	

Model	LM28CLS	LM35CLS	LM50CLS
Focal Length (mm)	28	35	50
Image Size (mm)	Φ30	Φ30	Φ30
Iris Range (F-Stop)	F2.8~F22	F2.8~F22	F2.8~F22
Focusing Range (m)	0.5~∞	0.5~∞	0.5~∞
Control	Iris Focus		
Shooting Range at M.O.D. (mm)	317.9 (V)	259.1 (V)	157.7 (V)
Angle of View (Degrees)	55.2 (V)	46.1 (V)	32.3 (V)
Resolution (Center, Corner)	160lp/mm, 63lp/mm	160lp/mm, 63lp/mm	160lp/mm, 63lp/mm
TV Distortion (%)	-0.1	0.06	-0.1
Back Focus in Air (mm)	37.2	36.9	35.6
Flange Back in air (mm)	46.5	46.5	46.5
Mount	Nikon F-mount	Nikon F-mount	Nikon F-mount
Filter Thread (mm)	M72×P0.75	M62×P0.75	M52×P0.75
Size (mm)	Φ75×108	Φ65×108	Φ58×63.5 (Min.) / Φ58×71.4 (Max.)
Weight (g)	482	480	358
Temperature Range	-10°C~+50°C	-10°C~+50°C	-10°C~+50°C

S-Mount Lens Series

1/1.8" S-MOUNT LENS 5MEGAPIXEL+ 2.5μm

1/2.5" S-MOUNT LENS 2MEGAPIXEL+ 3.1μm

Model	Format Size (Inch)							
	1	1/1.2	2/3	1/1.8	1/2	1/2.5	1/2.8	1/3
LM1.7QS25 / LM1.7QS25-IR65	-	-	-	-	●	●	●	●
LM1.7QS40 / LM1.7QS40-IR65	-	-	-	-	●	●	●	●
LM1.7QS56 / LM1.7QS56-IR65	-	-	-	-	●	●	●	●
LM3QS28 / LM3QS28-IR65	-	-	-	-	●	●	●	●
LM3QS40 / LM3QS40-IR65	-	-	-	-	●	●	●	●
LM3QS56 / LM3QS56-IR65	-	-	-	-	●	●	●	●
LM5NS21 / LM5NS21-IR65	-	-	-	-	●	●	●	●
LM5NS28 / LM5NS28-IR65	-	-	-	-	●	●	●	●
LM5NS40 / LM5NS40-IR65	-	-	-	-	●	●	●	●
LM5NS56 / LM5NS56-IR65	-	-	-	-	●	●	●	●

● Compatible ◊ Suitable * Incompatible

- Super-wide-angle lenses.
- Low distortion
- An optional IR-cut filter or lock ring can be attached.



LM1.7QS

LO-DIS XD



Model	Standard With IR-Cut Filter ¹⁾	LM1.7QS25 LM1.7QS25-IR65	LM1.7QS40 LM1.7QS40-IR65	LM1.7QS56 LM1.7QS56-IR65
Focal Length (mm)			1.7	
Image Size (mm)			5.70×4.28 (Φ7)	
Iris Range (F-Stop)		F2.5	F4	F5.6
Focusing Range (m)			0.1~∞	
Angle of View (Degrees)	1/2.5"		118.1 (H) × 102.8 (V)	
	1/2.8"		115.1 (H) × 89.1 (V)	
	1/3"		109.1 (H) × 93.0 (V)	
Resolution (Center, Corner)			160lp/mm, 100lp/mm	
TV Distortion (%)			-0.32	
Back Focus in Air (mm)			4.0	
Mount			S-mount (M12×P0.5)	
Size (mm)			Φ26.5×32.83	
Weight (g)			18	
Temperature Range			-10°C~+50°C	

LM3QS

LO-DIS XD

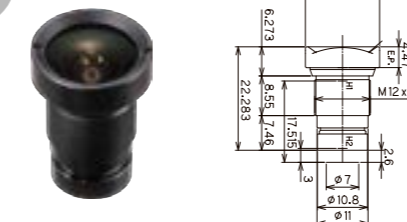

Model	Standard With IR-Cut Filter ¹⁾	LM3QS28 LM3QS28-IR65	LM3QS40 LM3QS40-IR65	LM3QS56 LM3QS56-IR65
Focal Length (mm)			3	
Image Size (mm)			5.70×4.28 (Φ7)	
Iris Range (F-Stop)		F2.8	F4	F5.6
Focusing Range (m)			0.1~∞	
Angle of View (Degrees)	1/2.5"		86.7 (H) × 70.6 (V)	
	1/2.8"		83.3 (H) × 58.2 (V)	
	1/3"		76.9 (H) × 61.6 (V)	
Resolution (Center, Corner)			160lp/mm, 125lp/mm	
TV Distortion (%)			0.02	
Back Focus in Air (mm)			3.9	
Mount			S-mount (M12×P0.5)	
Size (mm)			Φ16×22.3	
Weight (g)			6	
Temperature Range			-10°C~+50°C	

LM5NS

LO-DIS

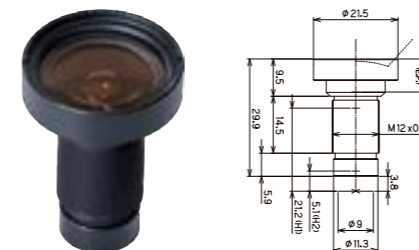

Model	Standard With IR-Cut Filter ¹⁾	LM5NS21 LM5NS21-IR65	LM5NS28 LM5NS28-IR65	LM5NS40 LM5NS40-IR65	LM5NS56 LM5NS56-IR65
Focal Length (mm)			5		
Image Size (mm)			7.2×5.4 (Φ9)		
Iris Range (F-Stop)		F2.1	F2.8	F4	F5.6
Focusing Range (m)			0.1~∞		
Angle of View (Degrees)	1/1.8"		72.4×57.0		
	1/2"		65.9×51.3		
	1/2.5"		59.8×46.2		
Resolution (Center, Corner)			200lp/mm, 100lp/mm		
TV Distortion (%)			-0.51		
Back Focus in Air (mm)			5.8		
Mount			S-mount (M12×P0.5)		
Size (mm)			Φ21.5×29.9		
Weight (g)			12		
Temperature Range			-10°C~+50°C		

Achieve Optimized Color Reproduction with an Optional IR-Cut Filter

Image sensors are sensitive to near-infrared (NIR) light, which is invisible to the human eye, and may capture unnatural reddish images depending on the illumination. Attaching an IR-cut filter effectively blocks unwanted NIR, allowing natural color reproduction close to what the human eye sees. Suitable for applications requiring accurate color reproduction, such as inspection, surveillance, and image analysis.



Transmission with IR-Cut Filter Attached

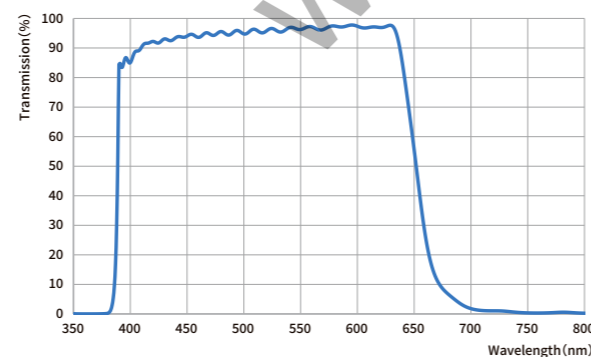



SC Lens Series

Model	LM12SC	LM16SC	LM25SC	LM35SC	LM50SC
Focal Length (mm)	12	16	25	35	50
Image Size (mm)	12.8×9.6 (Φ16)	12.8×9.6 (Φ16)	12.8×9.6 (Φ16)	12.8×9.6 (Φ16)	12.8×9.6 (Φ16)
Iris Range (F-Stop)	F1.8~F16	F1.8~F16	F1.8~F16	F2.0~F16	F2.0~F16
Focusing Range (m)	0.1~∞	0.1~∞	0.15~∞	0.2~∞	0.3~∞
Control	Iris: Manual Focus: Manual	Iris: Manual Focus: Manual	Iris: Manual Focus: Manual	Iris: Manual Focus: Manual	Iris: Manual Focus: Manual
Shooting Range at M.O.D. (mm)	125.5 (H) × 93.5 (V)	93.5 (H) × 69.9 (V)	86.1 (H) × 64.4 (V)	69.9 (H) × 52.4 (V)	70.1 (H) × 52.7 (V)
Angle of View (Degrees)	1" 55.9×43.1 2/3" 39.8×30.2 1/1.8" 32.9×24.9	44.0×33.6 30.9×23.3 25.5×19.2	28.9×21.8 20.1×15.2 16.5×12.4	20.8×15.6 14.3×10.8 11.7×8.8	14.6×11.0 10.1×7.6 8.3×6.2
Resolution (Center, Corner)	160lp/mm, 120lp/mm	160lp/mm, 120lp/mm	160lp/mm, 120lp/mm	160lp/mm, 120lp/mm	160lp/mm, 120lp/mm
TV Distortion (%)	-0.55	0.02	-0.34	0.02	0.30
Back Focus in Air (mm)	13.0	13.0	24.3	15.2	21.6
Mount	C-mount	C-mount	C-mount	C-mount	C-mount
Filter Thread (mm)	M40.5×P0.5	M34×P0.5	M34×P0.5	M34×P0.5	M34×P0.5
Size (mm)	φ48×82 (Min.) / φ43×84 (Max.)	φ43×80.0	φ43×89.0	φ43×74.0	φ43×78.5
Weight (g)	255	240	245	200	210
Temperature Range	-10°C~+50°C	-10°C~+50°C	-10°C~+50°C	-10°C~+50°C	-10°C~+50°C

JC3M2 Lens Series

Model	LM8JC3M2	LM12JC3M2	LM16JC3M2	LM25JC3M2	LM35JC3M2	LM50JC3M2
Focal Length (mm)	8	12	16	25	35	50
Image Size (mm)	8.8×6.6 (Φ11)	8.8×6.6 (Φ11)	8.8×6.6 (Φ11)	8.8×6.6 (Φ11)	8.8×6.6 (Φ11)	8.8×6.6 (Φ11)
Iris Range (F-Stop)	F1.4~Close	F1.4~Close	F1.4~F16	F1.4~F16	F2.0~F16	F2.8~F22
Focusing Range (m)	0.1~∞	0.15~∞	0.2~∞	0.2~∞	0.2~∞	0.2~∞
Control	Iris: Manual Focus: Manual	Iris: Manual Focus: Manual	Iris: Manual Focus: Manual	Iris: Manual Focus: Manual	Iris: Manual Focus: Manual	Iris: Manual Focus: Manual
Shooting Range at M.O.D. (mm)	120.3 (H) × 90.0 (V)	110.0 (H) × 82.5 (V)	112.8 (H) × 84.4 (V)	71.1 (H) × 53.3 (V)	47.9 (H) × 35.8 (V)	29.3 (H) × 21.9 (V)
Angle of View (Degrees)	2/3" 56.5×43.9 1/1.8" 47.4×36.3 1/2" 42.6×32.5	38.3×29.1 31.7×24.0 28.3×21.4	30.0×22.7 24.7×18.6 21.8×16.4	19.6×14.8 16.1×12.1 14.0×10.5	14.4×10.8 11.8×8.8 10.5×7.9	9.6×7.2 7.9×5.9 7.0×5.2
Resolution (Center, Corner)	120lp/mm, 100lp/mm	120lp/mm, 100lp/mm	120lp/mm, 100lp/mm	120lp/mm, 100lp/mm	120lp/mm, 100lp/mm	120lp/mm, 100lp/mm
TV Distortion (%)	-0.6	-0.07	-0.05	-0.04	-0.2	-0.03
Back Focus in Air (mm)	9.74	11.7	13.1	11.7	20.1	35.5
Mount	C-mount	C-mount	C-mount	C-mount	C-mount	C-mount
Filter Thread (mm)	M27×P0.5	M27×P0.5	M27×P0.5	M27×P0.5	M27×P0.5	M27×P0.5
Size (mm)	φ34×41.6 (Min.) / φ34×42.2 (Max.)	φ34×37 (Min.) / φ34×38.1 (Max.)	φ33.5×36.5 (Min.) / φ33.5×38.6 (Max.)	φ33.5×39.5 (Min.) / φ33.5×44 (Max.)	φ34×36.5 (Min.) / φ34×46.6 (Max.)	φ34×55 (Min.) / φ34×73.5 (Max.)
Weight (g)	90	85	85	90	70	95
Temperature Range	-10°C~+50°C	-10°C~+50°C	-10°C~+50°C	-10°C~+50°C	-10°C~+50°C	-10°C~+50°C

HC-IR Lens Series

Model	LM50HC-IR	LM60HC-IR
Focal Length (mm)	50	60
Image Size (mm)	12.8×9.6 (Φ16)	12.8×9.6 (Φ16)
Iris Range (F-Stop)	F1.8~F16	F2.0~F16
Focusing Range (m)	1.0~∞	1.0~∞
Control	Iris: Manual Focus: Manual	Iris: Manual Focus: Manual
Shooting Range at M.O.D. (mm)	246.0 (H) × 184.0 (V)	216.9 (H) × 162.1 (V)
Angle of View (Degrees)	1" 14.4×10.8 2/3" 9.9×7.5 1/1.8" 8.2×6.2	12.2×9.2 8.4×6.3 6.9×5.2
Resolution (Center, Corner)	160lp/mm, 125lp/mm	160lp/mm, 125lp/mm
TV Distortion (%)	-0.09	-0.06
Back Focus in Air (mm)	20.4	15.7
Mount	C-mount	C-mount
Filter Thread (mm)	M37.5×P0.5	M37.5×P0.5
Size (mm)	φ50×48.9 (Min.) / φ50×51.46 (Max.)	φ49.2×54.6
Weight (g)	180	200
Temperature Range	-10°C~+50°C	-10°C~+50°C

LM50-IR

Model	LM50-IR
Focal Length (mm)	50
Image Size (mm)	36×24 (Φ43.3)
Iris Range (F-Stop)	F1.9~F16
Focusing Range (m)	0.5~∞
Control	Iris: Manual Focus: Manual
Shooting Range at M.O.D. (mm)	366.9 (H) × 242.9 (V)
Angle of View (Degrees)	Full size 40.2×27.2 4/3" 21.0×15.8 1" 14.6×11.0
Resolution (Center, Corner)	100lp/mm, 50lp/mm
TV Distortion (%)	-0.5
Back Focus in Air (mm)	34.6
Mount	Nikon F-mount
Filter Thread (mm)	M52×P0.75
Size (mm)	φ58.5×105.2
Weight (g)	605
Temperature Range	-10°C~+50°C

LMZ45T3

* Please contact regional sales office to order.

Model	LMZ45T3
Magnification	inf~1.1×
Zoom magnification	6×
Image Size (mm)	8.8×6.6 (Φ11)
Close up lens	3Dpt.un-installed 3Dpt.installed
Shooting Magnification	Inf~0.72× 0.053~1.1×
W.D (mm)	Inf~M.O.D=185 WD=330~115
Iris Range (F-Stop)	F2.5~Close
TV Distortion (%)	-0.3 -0.1
Control	Iris: Manual Focus: Manual Zoom: Manual
Shooting Range (mm)	2/3" inf wide 27.3×20.5° WD=310 wide 165.4×123.8 inf tele 4.7×3.5° WD=310 tele 28.3×21.3 WD=310 wide 67.0×50.1 WD=150 wide 43.8×32.8 WD=310 tele 11.7×9.0 WD=150 tele 7.6×5.9 1/2" inf wide 19.9×14.9° WD=310 wide 120.0×89.8 inf tele 3.4×2.6° WD=310 tele 20.7×15.6 WD=310 wide 48.6×36.5 WD=150 wide 31.8×23.8 WD=310 tele 8.7×6.6 WD=150 tele 5.7×4.3 1/3" inf wide 14.9×11.2° WD=310 wide 89.8×67.4 inf tele 2.6×2.0° WD=310 tele 15.6×11.7 WD=310 wide 36.5×27.3 WD=150 wide 23.8×17.9 WD=310 tele 6.6×5.0 WD=150 tele 4.3×3.3
Mount	C-mount
Filter Thread (mm)	M52×P0.75
Size (mm)	φ62×171.7
Weight (g)	595
Temperature Range	-10°C~+50°C

Close Up Rings

Model	Specification
KW-EXT1	1mm
KW-EXT5	5mm
KW-EXT10	10mm
KW-EXT20	20mm
LMZ4S (Set of 4 Close Up Rings)	1mm, 5mm, 10mm, 20mm



Filter Holders

Attaching a filter holder enables the use of M30.5 x P0.5 filters with JC5MC Series lenses in 12mm, 16mm, and 25mm focal lengths.



Model	Specification
FL-12JC5MC	Φ32
FL-16JC5MC	
FL-25JC5MC	

Mount Adaptors

Mount adaptors allow flange back adjustment for VM42 Series lenses with 18mm, 25mm, and 35mm focal lengths.



Model	Flange Back (mm)	Mount Adaptors
FB-1600VM	16	M42-mount
FB-1148VM	11.48	M42-mount
FB-1000VM	10	M42-mount
FB-1200VM	12	M42-mount
FB-0656VM	6.56	M42-mount
FB-1750VM	17.5	TFL-II-mount



NF-C Conversion Adapter

This is a conversion adapter for attaching an NF-mount lens to a C-mount camera.

Model	Mount
KW-NFC	C-mount

*Not compatible with LM9NF lenses.



KW-NFC

S-C Conversion Adapters

This is a conversion adapter for attaching an S-mount lens to a C-mount camera.

Model	Mount
KW-SC1	C-mount
KW-SC3	

* When attaching to the camera, the dustproof glass must be removed.



KW-SC1



KW-SC3

S-mount Lock Rings

This is a lock ring for fixing the focus of an S-mount lens.

Model	Compatible Lenses
KW-LR1	S-mount Lens
KW-LR3	



KW-LR1



KW-LR3

Correspondence Table

Lenses	Conversion Adapters	Lock Rings
S-mount Series	LM5NS	KW-SC1
	LM3QS	KW-SC1
	LM1.7QS	KW-SC3
NF-mount Series	LM3NF	KW-NFC
	LM5NF	KW-NFC



XC Lens Series

LM8XC

WD (mm)	Magnification	Field of View (mm)									
		4/3"		1"		2/3"					
		H	V	H	V	H	V	H	V		
1000	0.008	2153.1	1614.2	1497.5	1121.8	1027.0	770.7				
950	0.009	2047.0	1534.6	1423.8	1066.6	976.4	732.7				
900	0.009	1940.6	1454.9	1349.8	1011.2	925.6	694.6				
850	0.010	1834.3	1375.2	1275.8	955.8	874.9	656.6				
800	0.011	1727.9	1295.4	1201.8	900.4	824.2	618.5				
750	0.011	1621.5	1215.7	1127.9	845.0	773.5	580.5				
700	0.012	1515.1	1136.0	1053.9	789.6	722.8	542.5				
650	0.013	1408.7	1056.2	979.9	734.2	672.1	504.4				
600	0.014	1302.3	976.5	906.0	678.8	621.4	466.4				
550	0.015	1195.9	896.7	832.0	623.4	570.7	428.3				
500	0.017	1089.3	816.8	757.9	567.9	519.9	390.2				
450	0.019	983.2	737.3	684.1	512.6	469.3	352.2				
400	0.021	876.8	657.5	610.1	457.2	418.6	314.2				
350	0.024	770.7	578.0	536.3	401.9	367.9	276.2				
300	0.028	663.8	497.9	462.0	346.3	317.1	238.0				
250	0.033	557.7	418.4	388.2	291.0	266.5	200.1				
200	0.041	451.2	338.5	314.1	235.6	215.7	162.0				
150	0.053	344.9	258.8	240.2	180.2	165.0	123.9				
100	0.077	238.4	179.1	166.4	124.9	114.5	85.9				

LM12XC

WD (mm)	Magnification	Field of View (mm)									
		4/3"		1"		2/3"					
		H	V	H	V	H	V	H	V		
1000	0.012	1562.6	1168.7	1082.6	806.5	737.2	551.2				
950	0.013	1485.8	1111.3	1029.5	766.9	701.0	524.2				
900	0.013	1409.1	1053.9	976.3	727.3	664.8	497.1				
850	0.014	1332.4	996.5	923.1	687.7	628.6	470.0				
800	0.015	1255.7	939.1	870.0	648.1	592.4	443.0				
750	0.016	1179.0	881.7	816.8	608.5	556.2	415.9				
700	0.017	1102.2	824.3	763.6	568.9	520.0	388.8				
650	0.018	1025.5	766.9	710.4	529.2	483.8	361.8				
600	0.020	948.8	709.5	657.3	489.6	447.6	334.7				
550	0.022	872.1	652.1	604.1	450.0	411.4	307.6				
500	0.024	795.3	594.7	550.9	410.4	375.2	280.6				
450	0.026	718.6	537.3	497.8	370.8	339.0	253.5				
400	0.029	641.9	479.9	444.6	331.2	302.8	226.4				
350	0.033	565.1	422.5	391.4	291.6	266.5	199.3				
300	0.039	488.4	365.1	338.2	252.0	230.3	172.2				
250	0.046	411.7	307.7	285.1	212.4	194.1	145.2				
200	0.056	334.6	250.0	231.6	172.6	157.8	118.0				
150	0.073	258.0	192.8	178.6	133.1	121.6	91.0				
100	0.104	181.5	135.5	125.5	93.5	85.6	63.9				

LM16XC

WD (mm)	Magnification	Field of View (mm)									
		4/3"		1"		2/3"					
		H	V	H	V	H	V	H	V		
1000	0.016	1187.5	887.7	822.8	614.7	562.3	421.4				
950	0.017	1129.0	844.0	782.3	584.4	534.7	400.6				
900	0.017	1070.5	800.3	741.8	554.2	507.0	379.9				
850	0.018	1012.1	756.6	701.3	523.9	479.3	359.2				
800	0.020	953.5	712.8	660.7	493.6	451.6	338.4				
750	0.021	895.2	669.2	620.3	463.4	424.0	317.7				
700	0.022	836.7	625.5	579.8	433.2	396.3	296.9				
650	0.024	778.2	581.8	539.3	402.9	368.6	276.2				
600	0.026	719.8	538.1	498.8	372.7	341.0	255.5				
550	0.028	661.3	494.4	458.3	342.4	313.3	234.8				
500	0.031	602.8	450.7	417.8	312.2	285.6	214.0				
450	0.034	544.3	407.0	377.3	281.9	257.9	193.3				
400	0.038	485.9	363.3	336.8	251.7	230.3	172.6				
350	0.044	427.4	319.6	296.3	221.4	202.6	151.8				
300	0.051	368.9	275.9	255.8	191.1	174.9	131.1				
250	0.060	310.5	232.3	215.3	160.9	147.2	110.4				
200	0.074	252.0	188.5	174.8	130.6	119.5	89.6				
150	0.096	193.4	144.7	134.2	100.3	91.8	68.8				
100	0.138	134.6	100.8	93.5	69.9	64.0	48.0				

FC24M Lens Series

LM6FC24M

WD (mm)	Magnification	Field of View (mm)									
		1.1"		1"		2/3"					
		H	V	H	V	H	V	H	V		
1000	0.007	2252.1	1669.3	2033.1	1506.4	1377.1	1026.1				
950	0.007	2141.3	1587.1	1933.1	1432.3	1309.4	975.6				
900	0.007	2030.4	1505.0	1833.0	1358.1	1241.6	925.1				
850	0.008	1919.6	1422.9	1732.9	1284.0	1173.8	874.6				
800	0.008	1808.7	1340.7	1632.9	1209.9	1106.1	824.1				
750	0.009	1697.9	1258.6	1532.8	1135.8	1038.3	773.6				
700	0.009	1587.0	1176.4	1432.8	1061.6	970.5	723.1				
650	0.010	1476.2	1094.3	1332.7	987.5	902.8	672.6				
600	0.011	1365.3	1012.1	1232.6	913.4	835.0	622.1				
550	0.012	1254.5	930.0	1132.6	839.2	767.2	571.6				
500	0.013	1143.6	847.8	1032.5	765.1	699.4	521.1				
450	0.014	1032.7	765.6	932.4	691.0	631.7	470.6				
400	0.016	921.9	683.5	832.3	616.8	563.9	420.1				
350	0.018	811.0	601.3	732.3	542.7	496.1	369.6				
300	0.021	700.1	519.2	632.2	468.5	428.3	319.1				
250	0.025	589.2	437.0	532.1	394.4	360.5	268.6				
200	0.031	478.2	354.8	431.9	320.2	292.7	218.1				
150	0.040	367.2	272.6	331.8	246.0	224.9	167.6				
100	0.057	255.8	190.1	231.2	171.6	156.9	117.0				

LM25XC

WD (mm)	Magnification	Field of View (mm)									
		4/3"		1"		2/3"					
		H	V	H	V	H	V	H	V		
1000	0.025	759.0	566.0	524.7	392.4	359.2	269.4				
950	0.026	721.7	538.2	498.9	373.1	341.5	256.1				
900	0.027	684.4	510.4	473.1	353.9	323.8	242.9				
850	0.029	647.1	482.5	447.3	334.6	306.2	229.7				
800	0.031	609.8	454.7	421.5	315.3	288.5	216.4				
750	0.033	572.5	426.9	395.8	296.0	270.9	203.2				
700	0.035	535.2	399.1	370.0	276.7	253.2	189.9				
650	0.037	497.9	371.3	344.2	257.4	235.6	176.7				
600	0.041	460.6	343.4	318.4	238.1	217.9	163.4				
550	0.044	423.3	315.6	292.6	218.8	200.2	150.2				
500	0.048	386.0	287.8	266.8	199.5	182.6	136.9				
450	0.054	348.7	259.9	241.0	180.2	164.9	123.7				
400	0.060	311.3	232.1	215.2	160.9	147.2	110.4				
350	0.068	274.0	204.3	189.3	141.6	129.6	97.2				
300	0.079	236.7	176.4	163.5	122.3	111.9	83.9				
250	0.094	199.3	148.5	137.7	102.9	94.2	70.7				
200	0.115	161.9	120.6	111.8	83.6	76.5	57.4				
150	0.150	124.8	93.0	86.1	64.4	59.0	44.2				

LM35XC

WD (mm)	Magnification	Field of View (mm)							
		4/3"		1"		2/3"			
		H	V	H	V				



LM12FC24M

Table with columns: WD (mm), Magnification, Field of View (mm) for 1.1", 1", and 2/3" magnifications.

LM50FC24M

Table with columns: WD (mm), Magnification, Field of View (mm) for 1.1", 1", and 2/3" magnifications.

HC Lens Series

LM4HC

Table with columns: WD (mm), Magnification, Field of View (mm) for 1", 2/3", and 1/1.8" magnifications.

LM16HC

Table with columns: WD (mm), Magnification, Field of View (mm) for 1", 2/3", and 1/1.8" magnifications.

LM16FC24M

Table with columns: WD (mm), Magnification, Field of View (mm) for 1.1", 1", and 2/3" magnifications.

LM75FC24M

Table with columns: WD (mm), Magnification, Field of View (mm) for 1.1", 1", and 2/3" magnifications.

LM6HC

Table with columns: WD (mm), Magnification, Field of View (mm) for 1", 2/3", and 1/1.8" magnifications.

LM25HC

Table with columns: WD (mm), Magnification, Field of View (mm) for 1", 2/3", and 1/1.8" magnifications.

LM25FC24M

Table with columns: WD (mm), Magnification, Field of View (mm) for 1.1", 1", and 2/3" magnifications.

LM100FC24M

Table with columns: WD (mm), Magnification, Field of View (mm) for 1.1", 1", and 2/3" magnifications.

LM8HC

Table with columns: WD (mm), Magnification, Field of View (mm) for 1", 2/3", and 1/1.8" magnifications.

LM35HC

Table with columns: WD (mm), Magnification, Field of View (mm) for 1", 2/3", and 1/1.8" magnifications.

LM35FC24M

Table with columns: WD (mm), Magnification, Field of View (mm) for 1.1", 1", and 2/3" magnifications.

LM12HC

Table with columns: WD (mm), Magnification, Field of View (mm) for 1", 2/3", and 1/1.8" magnifications.

LM50HC

Table with columns: WD (mm), Magnification, Field of View (mm) for 1", 2/3", and 1/1.8" magnifications.

LM75HC

Table with columns: WD (mm), Magnification, Field of View (mm) for 1", 2/3", and 1/1.8" magnifications.



JC5MC/JC5MC-WP Lens Series

LM8JC5MC/LM8JCM-WP

Table with columns: WD (mm), Magnification, Field of View (mm) for 2/3", 1/1.8", and 1/2" (H and V).

LM25JC5MC/LM25JCM-WP

Table with columns: WD (mm), Magnification, Field of View (mm) for 2/3", 1/1.8", and 1/2" (H and V).

LM12JC1MS/LM12JCM-V/LM12JCM-WP

Table with columns: WD (mm), Magnification, Field of View (mm) for 2/3", 1/1.8", and 1/2" (H and V).

LM35JC1MS/LM35JCM-V/LM35JCM-WP

Table with columns: WD (mm), Magnification, Field of View (mm) for 2/3", 1/1.8", and 1/2" (H and V).

LM12JC5MC/LM12JCM-WP

Table with columns: WD (mm), Magnification, Field of View (mm) for 2/3", 1/1.8", and 1/2" (H and V).

LM35JC5MC

Table with columns: WD (mm), Magnification, Field of View (mm) for 2/3", 1/1.8", and 1/2" (H and V).

LM16JC1MS/LM16JCM-V/LM16JCM-WP

Table with columns: WD (mm), Magnification, Field of View (mm) for 2/3", 1/1.8", and 1/2" (H and V).

LM50JC1MS/LM50JCM-V/LM50JCM-WP

Table with columns: WD (mm), Magnification, Field of View (mm) for 2/3", 1/1.8", and 1/2" (H and V).

LM16JC5MC/LM16JCM-WP

Table with columns: WD (mm), Magnification, Field of View (mm) for 2/3", 1/1.8", and 1/2" (H and V).

LM50JC5MC

Table with columns: WD (mm), Magnification, Field of View (mm) for 2/3", 1/1.8", and 1/2" (H and V).

LM25JC1MS/LM25JCM-V/LM25JCM-WP

Table with columns: WD (mm), Magnification, Field of View (mm) for 2/3", 1/1.8", and 1/2" (H and V).

LM75JC1MS

Table with columns: WD (mm), Magnification, Field of View (mm) for 2/3", 1/1.8", and 1/2" (H and V).

NC1M/NCM-WP/JC1M/JC1MS/JCM-V/JCM-WP Lens series

LM3NC1M/LM3NCM-WP

Table with columns: WD (mm), Magnification, Field of View (mm) for 1/1.8", 1/2", and 1/3" (H and V).

LM5JC1M/LM5JCM-V/LM5JCM-WP

Table with columns: WD (mm), Magnification, Field of View (mm) for 2/3", 1/1.8", and 1/2" (H and V).

LM6NC1M

Table with columns: WD (mm), Magnification, Field of View (mm) for 1/1.8", 1/2", and 1/3" (H and V).

LM8JC1MS/LM8JCM-V/LM8JCM-WP

Table with columns: WD (mm), Magnification, Field of View (mm) for 2/3", 1/1.8", and 1/2" (H and V).



JC10M Lens Series

LM3JC10M

Table with columns: WD (mm), Magnification, Field of View (mm) for 2/3", 1/1.8", and 1/2" lenses. Rows include magnification values from 0.004 to 0.032.

LM5JC10M

Table with columns: WD (mm), Magnification, Field of View (mm) for 2/3", 1/1.8", and 1/2" lenses. Rows include magnification values from 0.005 to 0.044.

LM8JC10M

Table with columns: WD (mm), Magnification, Field of View (mm) for 2/3", 1/1.8", and 1/2" lenses. Rows include magnification values from 0.008 to 0.066.

LM12JC10M

Table with columns: WD (mm), Magnification, Field of View (mm) for 2/3", 1/1.8", and 1/2" lenses. Rows include magnification values from 0.016 to 0.107.

LM16JC10M

Table with columns: WD (mm), Magnification, Field of View (mm) for 2/3", 1/1.8", and 1/2" lenses. Rows include magnification values from 0.016 to 0.139.

LM25JC10M

Table with columns: WD (mm), Magnification, Field of View (mm) for 2/3", 1/1.8", and 1/2" lenses. Rows include magnification values from 0.025 to 0.226.

LM35JC10M

Table with columns: WD (mm), Magnification, Field of View (mm) for 2/3", 1/1.8", and 1/2" lenses. Rows include magnification values from 0.035 to 0.349.

LM50JC10M

Table with columns: WD (mm), Magnification, Field of View (mm) for 2/3", 1/1.8", and 1/2" lenses. Rows include magnification values from 0.048 to 0.459.

EC-IR Lens Series

LM16EC-IR

Table with columns: WD (mm), Magnification, Field of View (mm) for 1.2", 1.1", and 1" lenses. Rows include magnification values from 0.001 to 0.032.

LM25EC-IR

Table with columns: WD (mm), Magnification, Field of View (mm) for 1.2", 1.1", and 1" lenses. Rows include magnification values from 0.0013 to 0.05.

LM35EC-IR

Table with columns: WD (mm), Magnification, Field of View (mm) for 1.2", 1.1", and 1" lenses. Rows include magnification values from 0.0018 to 0.070.

LM50EC-IR

Table with columns: WD (mm), Magnification, Field of View (mm) for 1.2", 1.1", and 1" lenses. Rows include magnification values from 0.003 to 0.106.



S-Mount Lens Series

LM1.7QS

Table with columns: WD (mm), Magnification, Field of View (mm) for 1/2.5", 1/2.8", 1/3.6" (H, V).

LM5NS

Table with columns: WD (mm), Magnification, Field of View (mm) for 1/2.5", 1/2.8", 1/3.6" (H, V).

LM3QS

Table with columns: WD (mm), Magnification, Field of View (mm) for 1/2.5", 1/2.8", 1/3.6" (H, V).

XC Series table with columns: Model, LM8XC, LM12XC, LM16XC, LM25XC, LM35XC, LM50XC.

FC24M Series table with columns: Model, LM6FC24M, LM8FC24M, LM12FC24M, LM16FC24M, LM25FC24M, LM35FC24M, LM50FC24M, LM75FC24M, LM100FC24M.

HC Series table with columns: Model, LM4HC, LM6HC, LM8HC, LM12HC, LM16HC, LM25HC, LM35HC, LM50HC, LM75HC.

JC10M Series table with columns: Model, LM3JC10M, LM5JC10M, LM8JC10M, LM12JC10M, LM16JC10M, LM25JC10M, LM35JC10M, LM50JC10M.

JC5M2 Series table with columns: Model, LM12JC5M2, LM16JC5M2, LM25JC5M2, LM35JC5M2.

JC5MC Series table with columns: Model, LM8JC5MC, LM12JC5MC, LM16JC5MC, LM25JC5MC, LM35JC5MC, LM50JC5MC.

JC5MC-WP Series table with columns: Model, LM8JC5MC-WP, LM12JC5MC-WP, LM16JC5MC-WP, LM25JC5MC-WP.

JC1MS Series table with columns: Model, LM8JC1MS, LM12JC1MS, LM16JC1MS, LM25JC1MS, LM35JC1MS, LM50JC1MS, LM75JC1MS, LM100JC1MS.

JC Series table with columns: Model, LM6JC, LM8JC, LM12JC, LM16JC, LM25JC, LM35JC, LM50JC.

NCL Series table with columns: Model, LM4NCL, LM5NCL, LM6NCL, LM12NCL.

EC-IR Series table with columns: Model, LM16EC-IR*, LM25EC-IR, LM35EC-IR, LM50EC-IR.

*1: When the Far Spacer is removed



Harsh Environment Resistant GigE Vision 0.48MP Camera

KC48GC3MX / KC48GC3CX

Table with columns: Distance to subject (mm) *1, LM3NF f=2.7mm (H, V), LM8RW f=8mm (H, V), LM12RW f=12mm (H, V), LM16RW f=16mm (H, V), LM25RW f=25mm (H, V). Rows show FOV data for distances from 3500mm to 200mm.

*1: Distance from the glass surface of the KC-RW1S to the subject

Harsh Environment Resistant GigE Vision 3MP GigE camera

KC300GC3MX / KC300GC3CX

Table with columns: Distance to subject (mm) *1, LM3NF f=2.7mm (H, V), LM8RW f=8mm (H, V), LM12RW f=12mm (H, V), LM16RW f=16mm (H, V), LM25RW f=25mm (H, V). Rows show FOV data for distances from 3500mm to 200mm.

*1: Distance from the glass surface of the KC-RW1S to the subject

Harsh Environment Resistant GigE Vision 1.3MP Camera

KC130GC3MX / KC130GC3CX

Table with columns: Distance to subject (mm) *1, LM3NF f=2.7mm (H, V), LM8RW f=8mm (H, V), LM12RW f=12mm (H, V), LM16RW f=16mm (H, V), LM25RW f=25mm (H, V). Rows show FOV data for distances from 3500mm to 200mm.

*1: Distance from the glass surface of the KC-RW1S to the subject

Harsh Environment Resistant IP Vision 2MP Camera

KC200NB1CX

Table with columns: Distance to subject (mm) *1, LM3NF f=2.7mm (H, V), LM8RW f=8mm (H, V), LM12RW f=12mm (H, V), LM16RW f=16mm (H, V), LM25RW f=25mm (H, V). Rows show FOV data for distances from 3500mm to 200mm.

*1: Distance from the glass surface of the KC-RW1S to the subject

Harsh Environment Resistant GigE Vision 3MP GigE camera

KC200GC3MX / KC200GC3CX

Table with columns: Distance to subject (mm) *1, LM3NF f=2.7mm (H, V), LM8RW f=8mm (H, V), LM12RW f=12mm (H, V), LM16RW f=16mm (H, V), LM25RW f=25mm (H, V). Rows show FOV data for distances from 3500mm to 200mm.

*1: Distance from the glass surface of the KC-RW1S to the subject

Custom Design

Partner with us to create the ideal camera and lens solution.

Kowa Customized Cameras and Lenses

We offer comprehensive services covering everything from design and prototyping to production, performance evaluation, and quality assurance.

We accept orders to design and manufacture a wide range of optical systems tailored to customer needs. Our capabilities extend beyond optics, offering complete system solutions that integrate mechanical, electrical, and software components.

Examples of Technical Development

- Optical systems for image processing
- Optical systems for 3D measurement
- Optical systems with built-in lighting
- Optical systems for surveillance
- Optical systems for robot vision
- Optical systems for laser scanning
- Optical systems for semiconductor manufacturing equipment
- Temperature-resistant and vibration-resistant optical systems
- Ultra-high resolution optical systems

Specializing in Semi-Custom to Fully Customized Solutions

- Reducing system size and achieving a compact form factor through seamless integration of camera and lens.
- Ability to change lens coatings based on performance or environmental demands.
- Support for telecentric lens customization, including magnification, W.D., and mount types.
- Flexible optical design and form factor optimization through cohesive lens-prism integration.
- Custom motorized focus solutions supported.
- Engineering expertise available for integrating systems into protective enclosures.
- Provision of integrated units with built-in lighting and image processing.



Tailored customization proposals available based on customer specifications.

Manufacturing Process Flow Chart

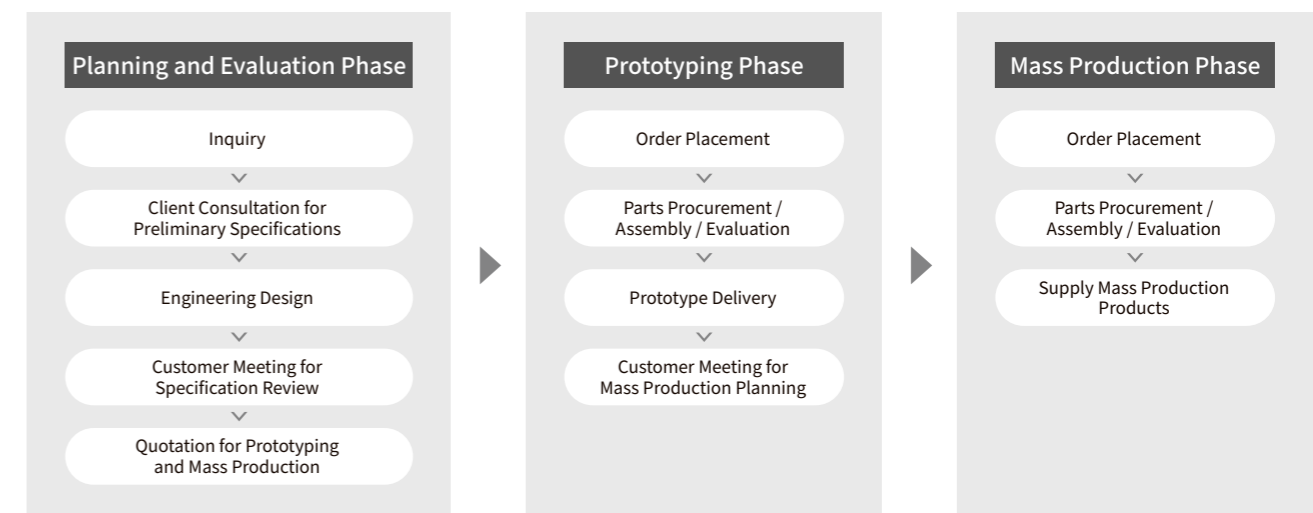

Comparison Table for Cameras and Lenses

Ruggedized GigE Vision Series

Camera Model / Described on Page	Lens Model
0.48MP Camera KC48GC4MX / KC48GC4CX	LM8JC1MS / LM12JC1MS / LM16JC1MS / LM25JC1MS / LM35JC1MS / LM50JC1MS / LM75JC1MS / LM100JC1MS P.41
	LM5JCM-WP / LM8JCM-WP / LM12JCM-WP / LM16JCM-WP / LM25JCM-WP / LM35JCM-WP / LM50JCM-WP P.55
	LM5JCM-V / LM8JCM-V / LM12JCM-V / LM16JCM-V / LM25JCM-V / LM35JCM-V / LM50JCM-V P.53
	LM5JC1M P.40
1.3MP Camera KC130GC4MX / KC130GC4CX	LM8JC1MS / LM12JC1MS / LM16JC1MS / LM25JC1MS / LM35JC1MS / LM50JC1MS / LM75JC1MS / LM100JC1MS P.41
	LM5JCM-WP / LM8JCM-WP / LM12JCM-WP / LM16JCM-WP / LM25JCM-WP / LM35JCM-WP / LM50JCM-WP P.55
	LM5JCM-V / LM8JCM-V / LM12JCM-V / LM16JCM-V / LM25JCM-V / LM35JCM-V / LM50JCM-V P.53
	LM5JC1M P.40
LM3NC1M / LM6NC1M P.39	
2MP Camera KC200GC4MX / KC200GC4CX	LM8JC1MS / LM12JC1MS / LM16JC1MS / LM25JC1MS / LM35JC1MS / LM50JC1MS / LM75JC1MS / LM100JC1MS P.41
	LM5JCM-WP / LM8JCM-WP / LM12JCM-WP / LM16JCM-WP / LM25JCM-WP / LM35JCM-WP / LM50JCM-WP P.55
	LM5JCM-V / LM8JCM-V / LM12JCM-V / LM16JCM-V / LM25JCM-V / LM35JCM-V / LM50JCM-V P.53
	LM3NC1M / LM6NC1M P.39
3MP Camera KC300GC4MX / KC300GC4CX	LM12JC5M2 / LM16JC5M2 / LM25JC5M2 / LM35JC5M2 P.35
	LM8JC1MS / LM12JC1MS / LM16JC1MS / LM25JC1MS / LM35JC1MS / LM50JC1MS / LM75JC1MS / LM100JC1MS P.41
	LM5JCM-WP / LM8JCM-WP / LM12JCM-WP / LM16JCM-WP / LM25JCM-WP / LM35JCM-WP / LM50JCM-WP P.55
	LM5JCM-V / LM8JCM-V / LM12JCM-V / LM16JCM-V / LM25JCM-V / LM35JCM-V / LM50JCM-V P.53
	LM5JC1M P.40
	LM3NC1M / LM6NC1M P.39
	LM8JC5MC / LM12JC5MC / LM16JC5MC / LM25JC5MC / LM35JC5MC / LM50JC5MC P.37
	LM8JC5MC-WP / LM12JC5MC-WP / LM16JC5MC-WP / LM25JC5MC-WP P.51
5MP Camera KC500GC4MX / KC500GC4CX	LM8JC5MC / LM12JC5MC / LM16JC5MC / LM25JC5MC / LM35JC5MC / LM50JC5MC P.37
	LM8JC5MC-WP / LM12JC5MC-WP / LM16JC5MC-WP / LM25JC5MC-WP P.51
	LM12JC5M2 / LM16JC5M2 / LM25JC5M2 / LM35JC5M2 P.35
8MP Camera KC800GC4MX / KC800GC4CX	LM3JC10M / LM5JC10M / LM8JC10M / LM12JC10M / LM16JC10M / LM25JC10M / LM35JC10M / LM50JC10M P.33
	LM6FC24M / LM8FC24M / LM12FC24M / LM16FC24M / LM25FC24M / LM35FC24M / LM50FC24M / LM75FC24M / LM100FC24M P.29
12MP Camera KC1200GC4MX / KC1200GC4CX	LM16EC-IR / LM25EC-IR / LM35EC-IR / LM50EC-IR P.57
	LM8XC / LM12XC / LM16XC / LM25XC / LM35XC / LM50XC P.27

Ruggedized CoaXPress Camera Series

Camera Model / Described on Page	Lens Model
0.48MP Camera KC48XS1MX	LM1.7QS25 / LM1.7QS40 / LM1.7QS56 / LM3QS28 / LM3QS40 / LM3QS56 P.73
	LM5NS21 / LM5NS28 / LM5NS40 / LM5NS56 P.73
1.3MP Camera KC130XC2MX / KC130XC2CX	LM8JC1MS / LM12JC1MS / LM16JC1MS / LM25JC1MS / LM35JC1MS / LM50JC1MS / LM75JC1MS / LM100JC1MS P.41
	LM5JCM-WP / LM8JCM-WP / LM12JCM-WP / LM16JCM-WP / LM25JCM-WP / LM35JCM-WP / LM50JCM-WP P.55
	LM5JCM-V / LM8JCM-V / LM12JCM-V / LM16JCM-V / LM25JCM-V / LM35JCM-V / LM50JCM-V P.53
	LM5JC1M P.40
LM3NC1M / LM6NC1M P.39	
3MP Camera KC300XC3MX / KC300XC3CX	LM12JC5M2 / LM16JC5M2 / LM25JC5M2 / LM35JC5M2 P.35
	LM8JC1MS / LM12JC1MS / LM16JC1MS / LM25JC1MS / LM35JC1MS / LM50JC1MS / LM75JC1MS / LM100JC1MS P.41
	LM5JCM-WP / LM8JCM-WP / LM12JCM-WP / LM16JCM-WP / LM25JCM-WP / LM35JCM-WP / LM50JCM-WP P.55
	LM5JCM-V / LM8JCM-V / LM12JCM-V / LM16JCM-V / LM25JCM-V / LM35JCM-V / LM50JCM-V P.53
	LM5JC1M P.40
	LM3NC1M / LM6NC1M P.39
	LM8JC5MC / LM12JC5MC / LM16JC5MC / LM25JC5MC / LM35JC5MC / LM50JC5MC P.37
	LM8JC5MC-WP / LM12JC5MC-WP / LM16JC5MC-WP / LM25JC5MC-WP P.51
5MP Camera KC500XC3MX / KC500XC3CX	LM8JC5MC / LM12JC5MC / LM16JC5MC / LM25JC5MC / LM35JC5MC / LM50JC5MC P.37
	LM8JC5MC-WP / LM12JC5MC-WP / LM16JC5MC-WP / LM25JC5MC-WP P.51
	LM12JC5M2 / LM16JC5M2 / LM25JC5M2 / LM35JC5M2 P.35

Harsh Environment Resistant GigE Vision Series

Camera Model / Described on Page	Lens Model
0.48MP Camera KC48GC3MX / KC48GC3CX	LM8JC1MS / LM12JC1MS / LM16JC1MS / LM25JC1MS / LM35JC1MS / LM50JC1MS / LM75JC1MS / LM100JC1MS P.41
	LM5JCM-WP / LM8JCM-WP / LM12JCM-WP / LM16JCM-WP / LM25JCM-WP / LM35JCM-WP / LM50JCM-WP P.55
	LM5JCM-V / LM8JCM-V / LM12JCM-V / LM16JCM-V / LM25JCM-V / LM35JCM-V / LM50JCM-V P.53
	LM5JC1M P.40
1.3MP Camera KC130GC3MX / KC130GC3CX	LM8JC1MS / LM12JC1MS / LM16JC1MS / LM25JC1MS / LM35JC1MS / LM50JC1MS / LM75JC1MS / LM100JC1MS P.41
	LM5JCM-WP / LM8JCM-WP / LM12JCM-WP / LM16JCM-WP / LM25JCM-WP / LM35JCM-WP / LM50JCM-WP P.55
	LM5JCM-V / LM8JCM-V / LM12JCM-V / LM16JCM-V / LM25JCM-V / LM35JCM-V / LM50JCM-V P.53
	LM5JC1M P.40
LM3NC1M / LM6NC1M P.39	
2MP Camera KC200GC3MX / KC200GC3CX	LM8JC1MS / LM12JC1MS / LM16JC1MS / LM25JC1MS / LM35JC1MS / LM50JC1MS / LM75JC1MS / LM100JC1MS P.41
	LM5JCM-WP / LM8JCM-WP / LM12JCM-WP / LM16JCM-WP / LM25JCM-WP / LM35JCM-WP / LM50JCM-WP P.55
	LM5JCM-V / LM8JCM-V / LM12JCM-V / LM16JCM-V / LM25JCM-V / LM35JCM-V / LM50JCM-V P.53
	LM3NC1M / LM6NC1M P.39
3MP Camera KC300GC3MX / KC300GC3CX	LM12JC5M2 / LM16JC5M2 / LM25JC5M2 / LM35JC5M2 P.35
	LM8JC1MS / LM12JC1MS / LM16JC1MS / LM25JC1MS / LM35JC1MS / LM50JC1MS / LM75JC1MS / LM100JC1MS P.41
	LM5JCM-WP / LM8JCM-WP / LM12JCM-WP / LM16JCM-WP / LM25JCM-WP / LM35JCM-WP / LM50JCM-WP P.55
	LM5JCM-V / LM8JCM-V / LM12JCM-V / LM16JCM-V / LM25JCM-V / LM35JCM-V / LM50JCM-V P.53
	LM5JC1M P.40
	LM3NC1M / LM6NC1M P.39
	LM8JC5MC / LM12JC5MC / LM16JC5MC / LM25JC5MC / LM35JC5MC / LM50JC5MC P.37
	LM8JC5MC-WP / LM12JC5MC-WP / LM16JC5MC-WP / LM25JC5MC-WP P.51
5MP Camera KC500GC3MX / KC500GC3CX	LM8JC5MC / LM12JC5MC / LM16JC5MC / LM25JC5MC / LM35JC5MC / LM50JC5MC P.37
	LM8JC5MC-WP / LM12JC5MC-WP / LM16JC5MC-WP / LM25JC5MC-WP P.51
	LM12JC5M2 / LM16JC5M2 / LM25JC5M2 / LM35JC5M2 P.35
8MP Camera KC800GC3MX / KC800GC3CX	LM3JC10M / LM5JC10M / LM8JC10M / LM12JC10M / LM16JC10M / LM25JC10M / LM35JC10M / LM50JC10M P.33
	LM6FC24M / LM8FC24M / LM12FC24M / LM16FC24M / LM25FC24M / LM35FC24M / LM50FC24M / LM75FC24M / LM100FC24M P.29
12MP Camera KC1200GC3MX / KC1200GC3CX	LM16EC-IR / LM25EC-IR / LM35EC-IR / LM50EC-IR P.57
	LM8XC / LM12XC / LM16XC / LM25XC / LM35XC / LM50XC P.27
16MP Camera KC1600GC3MX / KC1600GC3CX	LM6FC24M / LM8FC24M / LM12FC24M / LM16FC24M / LM25FC24M / LM35FC24M / LM50FC24M / LM75FC24M / LM100FC24M P.29
	LM16EC-IR / LM25EC-IR / LM35EC-IR / LM50EC-IR P.57
20MP Camera KC2000GC3MX / KC2000GC3CX	LM8XC / LM12XC / LM16XC / LM25XC / LM35XC / LM50XC P.27
	LM6FC24M / LM8FC24M / LM12FC24M / LM16FC24M / LM25FC24M / LM35FC24M / LM50FC24M / LM75FC24M / LM100FC24M P.29
24MP Camera KC2400GC3MX / KC2400GC3CX	LM16EC-IR / LM25EC-IR / LM35EC-IR / LM50EC-IR P.57
	LM8XC / LM12XC / LM16XC / LM25XC / LM35XC / LM50XC P.27

Harsh Environment Resistant IP camera

Camera Model / Described on Page	Lens Model
2MP camera KC200NB1CX	LM8JC1MS / LM12JC1MS / LM16JC1MS / LM25JC1MS / LM35JC1MS / LM50JC1MS / LM75JC1MS / LM100JC1MS P.41
	LM5JCM-WP / LM8JCM-WP / LM12JCM-WP / LM16JCM-WP / LM25JCM-WP / LM35JCM-WP / LM50JCM-WP P.55
	LM5JCM-V / LM8JCM-V / LM12JCM-V / LM16JCM-V / LM25JCM-V / LM35JCM-V / LM50JCM-V P.53
	LM5JC1M P.40
LM3NC1M / LM6NC1M P.39	

Fundamentals of Cameras and Lenses

Cameras and lenses are critical components for image processing inspections.

Image processing typically follows four stages:

① Imaging ② Transfer ③ Processing ④ Output

Cameras and lenses are directly involved in the first step (Imaging).

Although stage ③ (Processing) often receives the most focus, its effectiveness depends on capturing precise and stable images. Selecting the optimal camera and lens for the object and environment is the most effective way to ensure successful inspection results.

① **Imaging** Cameras, Lenses and Lighting

② **Transfer** Cables

③ **Processing** Software

④ **Output** External Devices

Our Cameras

Color and Monochrome

Color cameras are ideal when inspections require judgments based on color information, while monochrome cameras are recommended when color is not a determining factor.

In general, monochrome cameras offer higher sensitivity compared to color cameras. They also provide advantages in terms of faster shutter speeds and greater flexibility in adjusting depth of field.



Color



Monochrome

Frame Rate

The frame rate refers to the number of images a camera can output per unit of time and is typically expressed in frames per second (fps).

A higher fps value means shorter data transmission time and enables the camera to capture more images within a brief period. This is especially beneficial for continuously imaging fast-moving objects.

In addition, faster output times per frame allow image processing to begin sooner, helping to reduce overall cycle time in inspection systems.

fps = frames per second

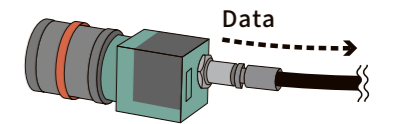

Resolution

Image sensors are built into cameras, and they determine the camera's resolution.

Higher-resolution cameras enable more detailed and precise inspections, making them suitable for applications that require fine image analysis.

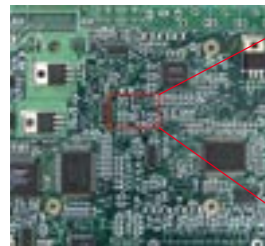

Actual Photograph

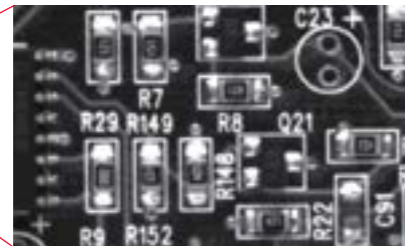

Low Resolution Image

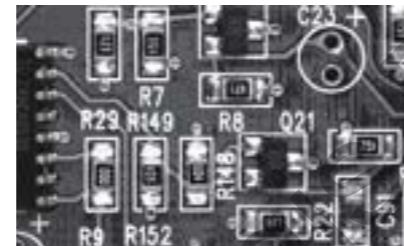

High Resolution Image

Industrial Camera Interfaces

When selecting a camera, the interface is one of the most critical factors to consider. Industrial camera interfaces connect the camera to a computer and transfer captured image data to the image processing system.

Higher-resolution image sensors produce larger data volumes per frame. As a result, cameras with high frame rates require interfaces that offer sufficient bandwidth to handle fast, large-volume data transfers.

Commonly used industrial interfaces include GigE, CoaXPress, USB 3.0, and Camera Link. Each interface varies in terms of data transfer speed, number of connectable cameras, and maximum cable length. In addition to the application's purpose, it is also important to consider the installation environment when selecting the appropriate interface.



Shutter Systems

There are two main types of image sensors: global shutter and rolling shutter.

In a rolling shutter system, the image is captured line by line in sequence, resulting in slight differences in exposure timing across the frame. When imaging moving objects, this can cause distortion, commonly known as the rolling shutter effect.

By contrast, a global shutter system exposes the entire image simultaneously, eliminating this type of distortion. For accurate imaging of moving objects, the use of a global shutter is essential.

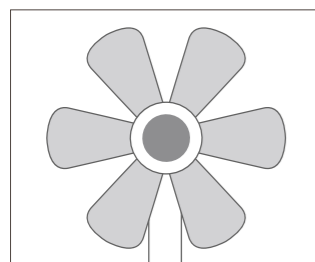

Global Shutter

Makes it possible to capture moving objects as if they are not in motion.

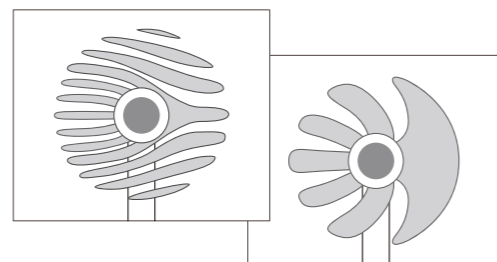

Rolling Shutter

Distortion may occur when imaging moving objects.

Dustproof and Waterproof

Dustproof and waterproof protection is essential in environments where equipment is exposed to water or fine dust, such as particles from paper or fabric.

We have products that are designed based on IP67 and IP69K* standards, ensuring reliable protection against dust and water. Oil-resistant models are also available for use in harsh industrial settings. Some cameras and lenses are built with integrated dustproof and waterproof features, while others achieve environmental protection through the use of dedicated housings, allowing flexibility based on the application.

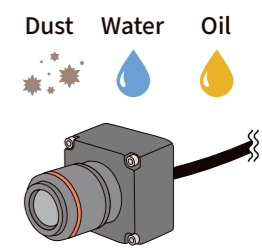

Our Lenses

Image Size

Image size varies across lens series and refers to the area of the image that passes through the lens and can be captured. As long as the lens's image size is equal to or larger than the camera's sensor size (see figure at right), the lens is compatible and can be used effectively.

Image Sensor Size

Camera	Horizontal H (mm)	Vertical V (mm)	Diagonal D (mm)
1/4"	3.6	2.7	4.5
1/3"	4.8	3.6	6
1/2"	6.4	4.8	8
1/1.8"	7.2	5.4	9
2/3"	8.8	6.6	11
1"	12.8	9.6	16
1.1"	14.1	10.6	17.6
1.2"	15.4	11.5	19.2
4/3"	18.4	13.8	23
APS-C	22.3	16.7	27.9
2(Φ32)"	25.6	19.2	32

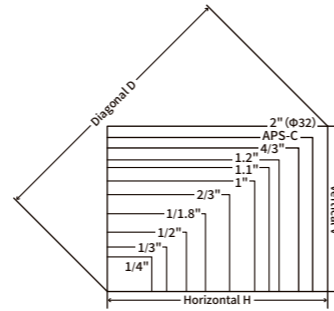

Focal Length

The imaging area is determined by the focal length, the sensor size, and the working distance (W.D.), which is the distance from the front of the lens to the object. As shown in the figure at the right, the focal length is the distance from the lens to the image sensor. A shorter focal length results in a wider field of view, while a longer focal length provides a more magnified view of the object. To achieve optimal imaging results, it is important to select a lens with a focal length that matches both the object size and the required working distance.

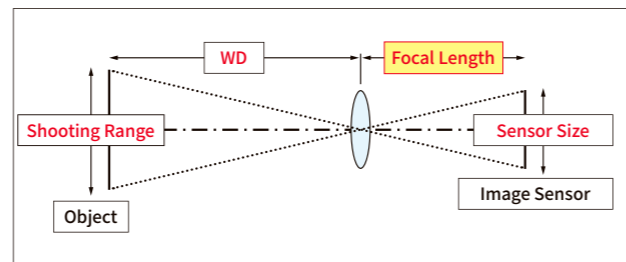

F-Stop (Aperture)

The brightness of a lens is indicated by its F-Stop, calculated by dividing the focal length by the effective diameter of the lens. This value can be adjusted using the aperture. Lenses with smaller F-Stops (brighter lenses) allow more light to pass through, enabling faster shutter speeds. On the other hand, larger F-Stops (darker lenses) increase the depth of field, allowing a wider range of the image to remain in focus.

F-Stop (Aperture Value) = The size of the opening through which light passes through a lens.

A large amount of light enters the lens. Increase the aperture size. → Only a small amount of light enters the lens. Decrease the aperture size.

The F-Stop follows a standard sequence: 1, 1.4, 2, 2.8, 4, 5.6, 8, 11, 16. Each step in this sequence corresponds to halving or doubling the amount of light that reaches the sensor. This is because the F-Stop is based on the aperture diameter, and when the radius of the aperture is reduced by a factor of 1/√2, the area through which light enters becomes half. As a result, the light intensity is also halved.

Two times brighter (1 to 1.4), Two times brighter (1.4 to 2), Half as bright (2 to 2.8), Half as bright (2.8 to 4), Half as bright (4 to 5.6), Half as bright (5.6 to 8), Half as bright (8 to 11), Half as bright (11 to 16).

Depth of Field

Depth of field refers to the range within which the image remains in acceptable focus. It is influenced by three main factors: F-Stop, working distance (W.D.), and focal length. The depth of field increases when the F-Stop is raised, the working distance is extended, or the focal length is shortened. Adjusting these parameters allows for better control over what portions of the image appear sharp.

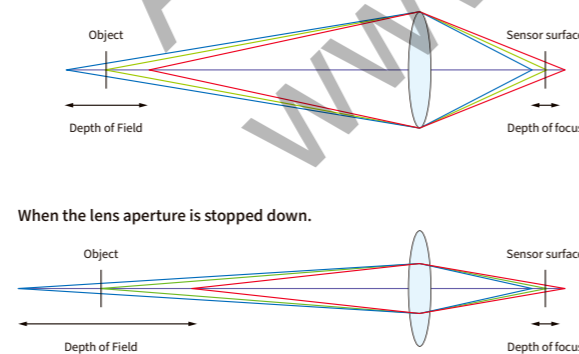

Distortion

Distortion is a phenomenon where the captured image appears warped or deformed. When distortion is present, the shape of the imaged object may differ from its actual shape, leading to inaccuracies in position or dimensional information during inspections or image processing. For this reason, low-distortion lenses are essential in applications that require high precision, as they maintain accurate image geometry and ensure reliable measurement results.

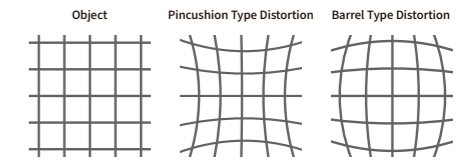

Resolving Power

Resolving power refers to the lens's ability to reproduce the fine details and edges of an object clearly. It is typically measured using black and white striped patterns, and is expressed as the number of line pairs that can be distinguished within a 1 mm width. This value is indicated in lp/mm (line pairs per millimeter), where a higher number represents greater detail resolution.

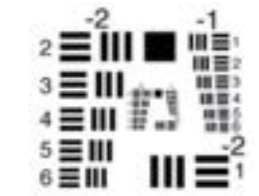

Floating Mechanism Design

Floating mechanisms, also known as close-range aberration compensating mechanisms, are effective in minimizing performance degradation across varying working distances. In conventional lenses, all lens elements move together when adjusting focus. This often results in a decline in optical performance depending on the working distance. In contrast, lenses equipped with floating mechanisms divide internal lens elements into multiple groups. These groups move independently, allowing the lens to maintain optimal performance across a range of working distances. As a result, floating mechanisms enable lenses to deliver consistently high image quality, even during close-range imaging.

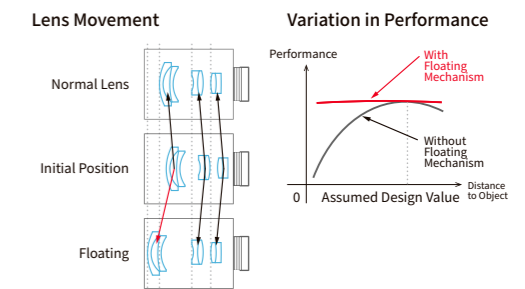

Lens Coatings

-High light transmission from visible to near-infrared (NIR) wavelengths.
-Can be used in a wide range of applications.

Wide-Band Multi-Coating

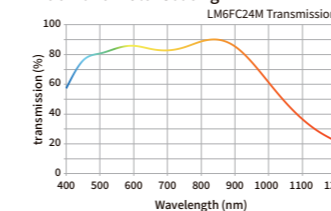

-High transmission from the visible range to short wavelength infrared (SWIR).
-A wide range of wavelength bands.

EX Wide-Band Multi-Coating

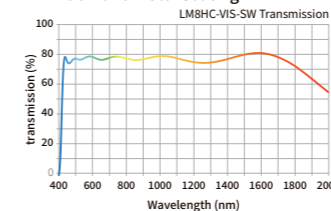

-Coatings optimized for high transmission in the short wavelength infrared (SWIR) range.

SWIR Coating

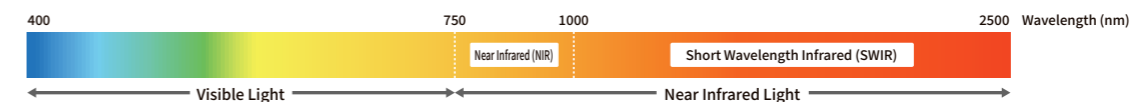
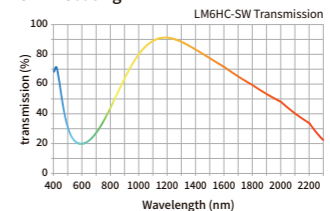

For each lens series, coatings are optimized to suit the specific needs of various wavelength bands, ensuring they are ideally suited for a wide range of applications.



Kowa Optronics Co.,Ltd.

2F Kudan Center Bldg. 4-1-7, Kudan-Kita, Chiyoda-Ku, Tokyo 102-0073, Japan
Phone: +81(3)6272-5967 Facsimile: +81(3)6380-8036
E-mail: opt-cctv@kowa.co.jp

Kowa American Corporation

20001 South Vermont Avenue, Torrance, CA 90502, U.S.A.
Phone: +1(310)327-1913
E-mail: customerservice@kowa.com URL: <http://www.kowa-usa.com>

Kowa Optimed Deutschland GmbH

Fichtenstrasse 123, 40233 Dusseldorf, Germany
Phone: +49 (0)211-542184-00
E-mail: lens@kowaoptimed.com URL: <https://www.kowaoptimed.com>

Kowa Skymech Pte. Ltd.

11B, Tuas Road, Jurong Industrial Estate, Singapore 638508
Phone: +65-6862-6930
E-mail: sales@skymech.com.sg URL: <https://www.kowa-skymech.com>

Kowa (Shanghai) Company. Ltd.

RM 3001, 3007, 3008, RAFFLES CITY SHANGHAI (OFFICE TOWER),
No. 268 MID XI ZANG ROAD, SHANGHAI, 200001, CHINA
TEL: +86 (21)-6340-3802*113
E-mail: infohp@kowashanghai.com URL: <http://www.kowashanghai.com>

Kowa India Pvt. Ltd.

Ahmedabad Branch

Ahmedabad Branch 5th Floor, Aravalli Bldg., Nr. Adani Corporate House,
Shantigram Vaishnodevi Circle, SG Highway, Ahmedabad 382421 Gujarat, India
Phone: +91-79-25554472
hardik@kowaindia.com URL: <https://kowaindia.com>

Kowa-Emori (Thailand) Co.,Ltd.

90/28, 11th Floor, Sathorn Thani Bldg. 1,
North Sathorn Road, Silom, Bangrak, Bangkok 10500 Thailand
Phone: +66-2-238-2606
opt-cctv@kowa.co.jp URL: <https://www.emori.co.jp/en>

<https://www.kowa-opt.co.jp/en/>



2026 Edition
KC/KL-EN_202602_SN-0