

**Europe / Middle East / Africa**

**FUJIFILM Electronic Imaging Europe GmbH**

Fujistraße 1, 47533 Kleve, Germany  
TEL: +49 (0) 2821 7115 400, FAX: +49 (0) 2821 7115 400  
E-mail: cctv\_eu@fujifilm.com

**FUJIFILM España. Fujifilm Europe GmbH. Sucursal en España**

Calle Virgilio 25 A, 1ª planta, Local C  
Edificio Ayessa II - Ciudad de la Imagen  
28223 Pozuelo de Alarcón, Madrid, Spain  
TEL: +34 914 670 479  
E-mail: imaging\_feg-es@fujifilm.com

**FUJIFILM France**

5 avenue des CHAUMES - CS 40760 MONTIGNY  
78066 SAINT QUENTIN EN YVELINES CEDEX - FRANCE  
TEL: +33 (0) 1 30 14 34 5, Fax: +33 (0) 1 34 60 57 45

**FUJIFILM Italia S.p.A.**

S.S.11 Padana Superiore 2/B  
20063 Cernusco Sul Naviglio (MI) ITALY  
TEL: +39 02 929741  
E-mail: optical\_devices\_ffit@fujifilm.com

**FUJIFILM Nordic AB**

Hantverkargatan 25B  
SE-112 21 Stockholm / Sweden  
TEL: +46 (8) 525 23 760  
E-mail: opticaldevices\_nordic.fnr@fujifilm.com

**FUJIFILM RUS LLC**

1st Magistralnyi tupik, 5A Business Centre  
"Magistral Plaza" 4th floor 123290, Moscow, Russia  
TEL: +7 495 797 3512, Fax: +7 495 797 3513  
E-mail: info\_ffru@fujifilm.com

**FUJIFILM Dış Ticaret A.Ş.**

Pürtelaş Hasan Efendi Mah. Medis-i Mebusan Cad. No: 37/A  
Beyoğlu İstanbul, Türkiye  
TEL: +90 212 709 92 42, Fax: +90 212 698 99 70  
Email: fujinon@fujifilm.com.tr

**FUJIFILM UK Ltd.**

88 Bushy Road (c/o Racetech), Raynes Park, Merton,  
London SW20 0JH, UK  
TEL: +44 (0) 208-944-4246  
E-mail: lenses\_uk@fujifilm.com

**FUJIFILM Middle East**

Jafza view 19 building, 23rd floor, Downtown Jebel Ali  
P.O Box: 17212, Dubai, UAE  
TEL: +971-4-887-8722

**China**

**FUJIFILM (China) Investment Co., Ltd.  
Optical Device Business Division**

28F, Shanghai ONELUJIAZUI, No.68 YinCheng Road(M),  
Pudong New Area, Shanghai, P.R.China 200120  
TEL: +86-21-5010-6000 \*384  
FAX: +86-21-5010-6730

**Hong Kong / Taiwan**

**FUJIFILM Hong Kong Limited  
Optical Device Division**

Unit 1001-1007, 10/F., Metroplaza Tower 2,  
223 Hing Fong Road, Kwai Fong, N.T., Hong Kong.  
Tel: (852) 2376-0998 Fax: (852) 2724-1118

**Southeast Asia & West Asia**

**FUJIFILM Asia Pacific Pte Ltd.**

10 New Industrial Road, Fujifilm Building Singapore 536201  
TEL: +65 (0)63839933 FAX: +65 (0)63835666

**Japan / North East Asia**

**FUJIFILM Corporation**

Optical Device & Electronic Imaging Products Div.  
1-324 Uetake, Kita-ku, Saitama City Saitama, 331-9624, Japan  
TEL: +81 (0)48-668-2152 FAX: +81 (0)48-651-8517

**Oceania**

**FUJIFILM Australia Pty Ltd.**

114 Old Pittwater Road, Brookvale, N.S.W. 2100, Australia  
TEL: +61 (0)2-9466-2600 FAX: +61 (0)2-9905-3801

**North & Latin America**

**FUJIFILM North America Corporation  
Optical Devices Division**

10 High Point Drive, Wayne, NJ 07470  
TEL: +1-973-633-5600 FAX: +1-973-633-5216



Authorized Fujifilm Service Agent.

Due to a continuous process of product improvement, design and specifications are subject to change without notice.  
All photos, illustrations, drawings and other images in this brochure are intended for illustrative purpose only.



Be certain to read the instructions for use before using any equipment.

FFBX-2022.09

**FUJINON**  
**Machine Vision Lenses**



## Product Line-up

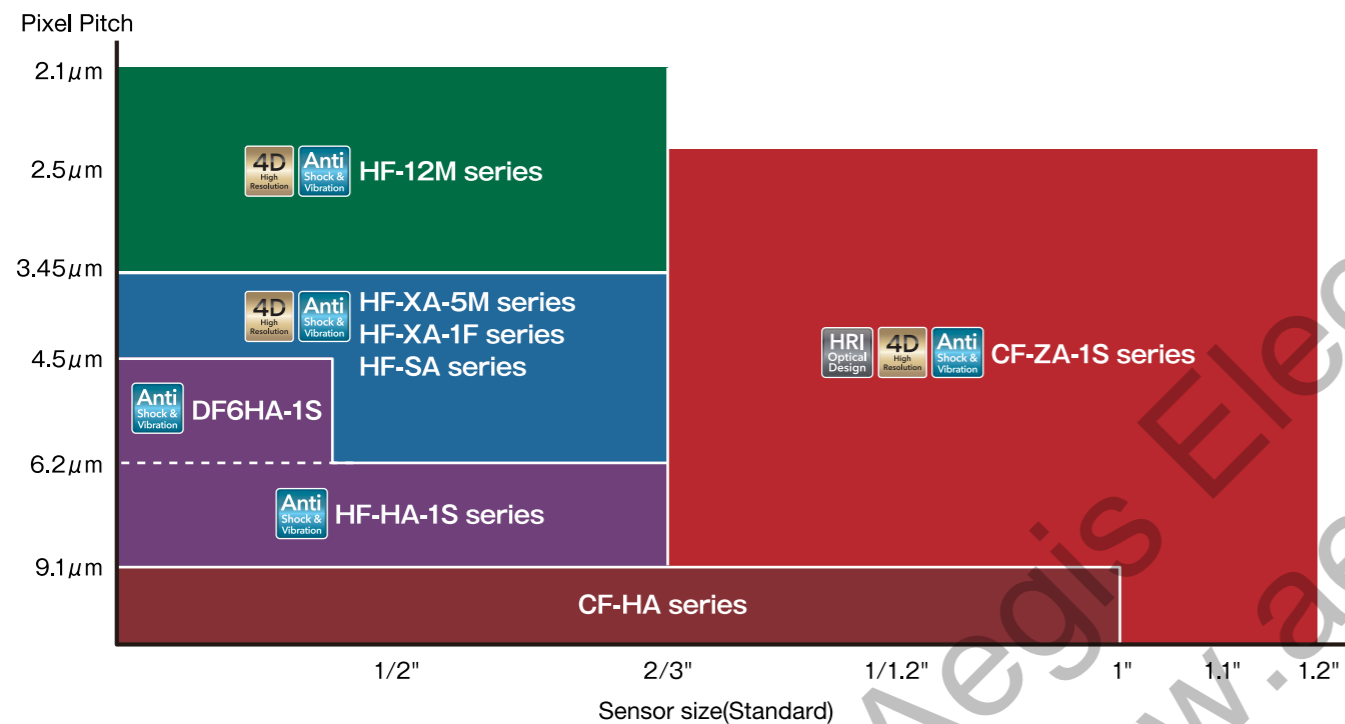

## Contents

	PAGE		PAGE
CF-ZA-1S series 24MP, 1.2"	04	HF-SA series 5MP, 2/3"	11
HF-12M series 12MP, 2/3"	06	CF-HA series 1.5MP, 1"	12
HF-XA-5M series 5MP, 2/3"	07	FE185 series Fisheye lens	13
HF-XA-1F series 5MP, 2/3"	08	Shooting Range Chart	14
HF-HA-1S series 1.5MP, 1/2"-2/3"	10		

Please refer to the details on page 3 and 4.



4D High Resolution(P3)



Anti-Shock and Vibration(P3)



High Relative Illumination(P4)

# Technologies supporting FUJINON lenses



## 4D High Resolution performance

- The "4D High Resolution" is the FUJINON lenses' unique performance. It maintains a high level of consistent image sharpness at the center as well as around the edges while mitigating resolution degradation that typically occurs when changing a working distance or aperture value. This enables the stable delivery of high-resolution images under a wide variety of installation and shooting conditions.

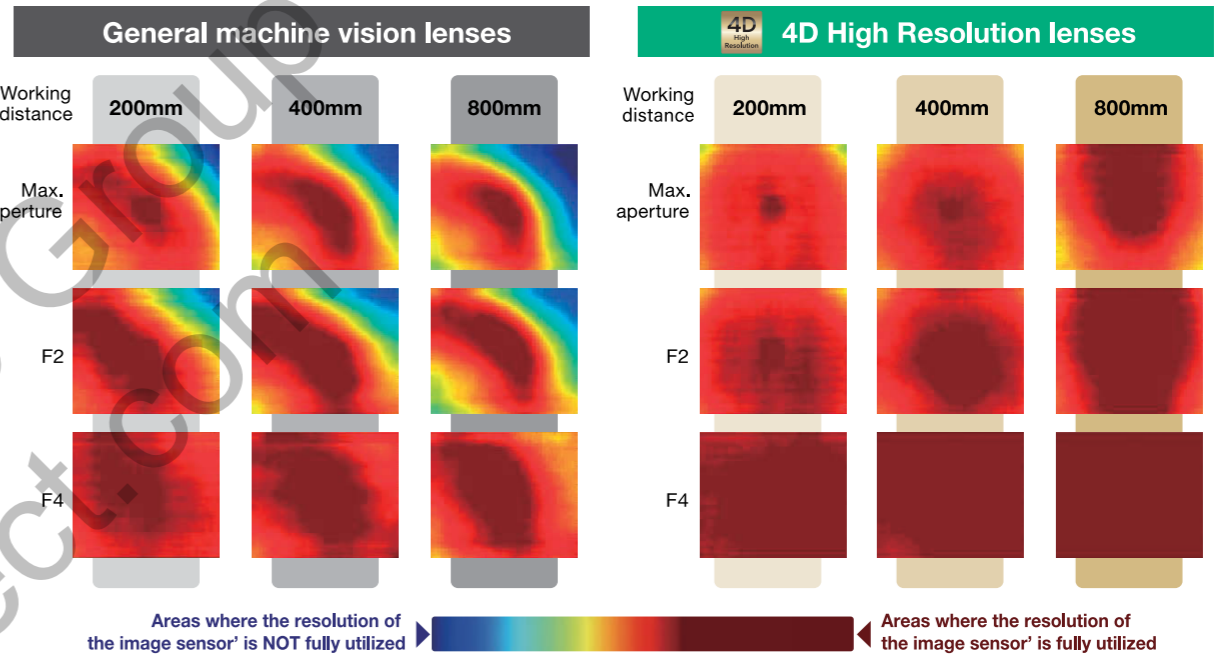

## Anti Shock & Vibration

### Anti-Shock : suppresses the optical axis shifts to less than 10µm.

- In the case of ordinary machine vision lenses, the optical axis shifts occur when the lens elements move from their initial position due to shocks. This affects the precise measurement performance of the lens. FUJINON's original\*1 Anti-Shock design suppresses the optical axis shifts to less than 10µm even when given shocks up to 10G\*2.

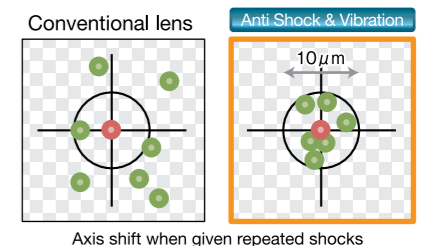

### Anti-Vibration : maintains high resolution

- The ordinary machine vision lenses have problems of toughness under working environments with vibration. FUJINON Anti-Vibration lenses have passed severe vibration tests conforming to IEC60068-2-6 and maintain superb resolution.

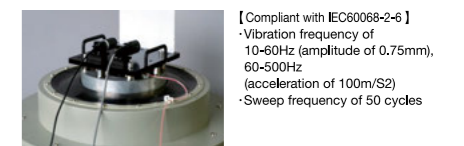

\*1: Patent applied for  
 \*2: Maximum impact tolerance varies by model

### Restrain aged deterioration

- The unique mechanical design minimizes the use of adhesives to withstand aged deterioration caused by humidity and heat.

## Thorough quality control on individual units

- Individual lens units are tested for their optical performance at the factory. Serial No information on the lens is an evidence of the complete quality management. (CF-ZA-1S series, HF-12M series and HF-XA-5M series)



# CF-ZA-1S series, 1.1"-4/3"\*1, 2.74μm, 24MP



## High Relative Illumination

- The advancement of image sensors for Machine Vision tends to larger sensors and smaller pixels. These sensors require a strong light transmission and a small Chief Ray Angle (CRA) so that the sufficient light reaches vertically on the photodiodes of each pixel. CF-ZA-1S series adopts rear lens groups with a large diameter enabled by FUJINON's high-precision assembly technology and achieves a CRA below 5°. This guarantees a high relative illumination across the entire image without vignetting.
- This series eliminates the need for luminance correction with image processing that just amplifies the noise.

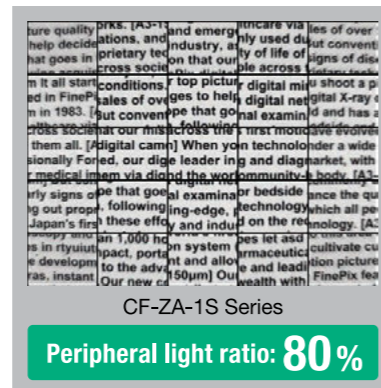
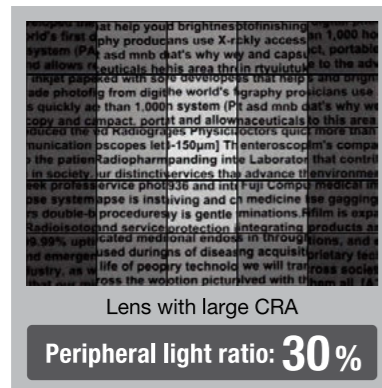

## 4D High Resolution performance

- Thanks to the 4D High Resolution Design, the resolving power remains consistently high from the center of the image to the edges, even at changing working distances or aperture settings.
- The CF-ZA-1S series draws out the full capability of cameras equipped with a 1.1" sensor with 3.45 μm pixel pitch (equivalent to 12 MP) across the entire frame. These lenses are the perfect choice especially for IMX253 (1.1" type sensor) and IMX225 (1" type sensor).
- The series supports next generation sensors with 1.2" optical format and 2.74μm pixel pitch (equivalent to 24 MP).

### "4D High Resolution" lenses

### General machine vision camera

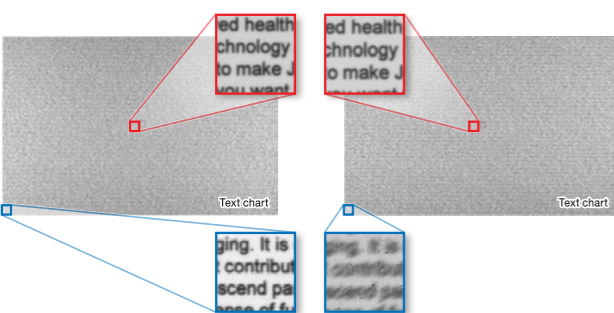

## Anti-Vibration and Shock Design

- This series maintains an advanced level of resolution before and after tough vibration tests, conducted according to JIS C 60068-2-6\*2. Even in applications that involve shocks, such as robot vision and 3D scanners, the optical axis shift remains less than 10μm for shocks of up to 10G\*3.
- The Fujifilm original mechanical design\*4 minimizes the use of adhesive to avoid aged deterioration caused by humidity and heat.

## High usability and reliability

- These lenses come with knurled screws for fixing the iris and focus position. The screws can't fall out accidentally, get lost or damage sensitive manufacturing machines during installation or maintenance.



## Compact size of only 39mm outer diameter

- Despite the support of sensors with large 1.2" format, all models of the CF-ZA-1S series offer a uniform diameter of only 39mm and are therefore no larger than standard machine vision cameras. Only the 8mm focal length CF8ZA-1S is slightly larger with a diameter of 54mm in the front lens.



- Thanks to the 3 holes on the lens barrel for fixing iris and focus positions, the most suitable hole can be selected for each application.
- By adopting an internal mechanical focus, the overall length of lens will not change when focused.
- The introduction of a focusing indicator at the working distance of 50cm enables efficient detection of cameras' flange back deviation.



	CF8ZA-1S	CF12ZA-1S	CF16ZA-1S	CF25ZA-1S	CF35ZA-1S	CF50ZA-1S
Focal length [mm]	8	12	16	25	35	50
Iris range [F. no]	F1.8-F16	F1.8-F16	F1.8-F16	F1.8-F16	F1.8-F16	F2.4-F16
Angle of view	85.7°×67.5°	62.5°×47.8°	47.3°×36.1°	32.9°×24.8°	23.0°×17.3°	16.6°×12.5°
Working Distance*1 [mm]	∞-100	∞-100	∞-100	∞-100	∞-200	∞-200
Operation of focus	Manual	Manual	Manual	Manual	Manual	Manual
Operation of iris	Manual	Manual	Manual	Manual	Manual	Manual
Filter thread [mm]	M52×0.75	M37.5×0.5	M37.5×0.5	M37.5×0.5	M37.5×0.5	M37.5×0.5
Mount	C-mount	C-mount	C-mount	C-mount	C-mount	C-mount
Weight (approx.) [g]	180	180	180	170	165	155
Sensor size (std.)*2	1.1"(2.5μm) 1.2"(2.74μm)	1.1"(2.5μm) 1.2"(2.74μm)	1.1"(2.5μm) 1.2"(2.74μm)	1.1"(2.5μm) 1.2"(2.74μm)	1.1"(2.5μm) 1.2"(2.74μm)	1.1"(2.5μm) 1.2"(2.74μm)
Sensor size (max.)*3	-	-	-	4/3"(3.45μm)	4/3"(3.45μm)	4/3"(3.45μm)
CRA (Chief Ray Angle)	4.5	4.5	4.9	2.7	4.5	4.8
TV distortion [%]	-4.81	-2.82	-0.80	-0.83	-0.32	-0.17
Dimension [mm]	ø54×67	ø39×67.6	ø39×67.6	ø39×67.3	ø39×67.3	ø39×68

### CF8ZA-1S

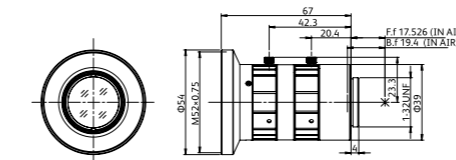

### CF12ZA-1S

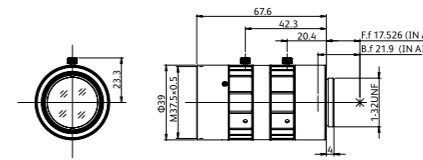

### CF16ZA-1S

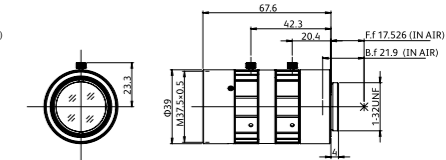

### CF25ZA-1S

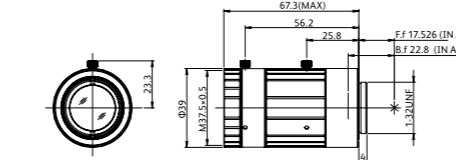

### CF35ZA-1S

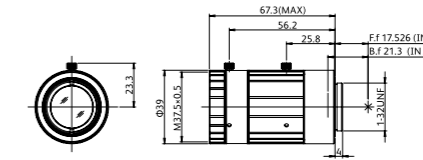

### CF50ZA-1S

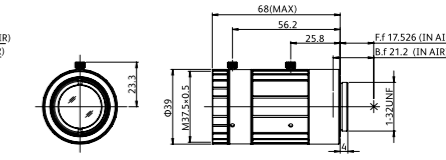

\*1 Sensor size(max.): Adaptable sensor size varies depending on the model. Please check the amount of light and resolution on the edges pertaining to your particular application. \*2 Compliance with JIS C 60068-2-6: Vibration frequency 10-60Hz (amplitude 0.75mm) vibration frequency 60-500Hz (acceleration 100m/S<sup>2</sup>) and 50 sweep cycles. \*3 Supported shock G value varies from model to model. \*4 FUJIFILM's patent-pending proprietary technology.

\*1 From front of lens barrel. \*2 Sensor size(std.): Ideal size to maximize the target resolution. \*3 Sensor size(max.): Adaptable sensor size varies depending on the model. Please check the amount of light and resolution on the edges pertaining to your particular application.

# HF-12M series, 2/3"-1" \*3, 2.1μm, 12MP

Maximum sensor size: 8mm/12mm=2/3", 16mm/25mm=1/1.2", 35mm=1"



- Low distortion
- Compact design



	Anti Shock & Vibration HF818-12M	Anti Shock & Vibration HF1218-12M	Anti Shock & Vibration HF1618-12M	Anti Shock & Vibration HF2518-12M	Anti Shock & Vibration HF3520-12M
Focal length [mm]	8	12	16	25	35
Iris range [F. no]	F1.8-F22	F1.8-F22	F1.8-F22	F1.8-F22	F2.0-F22
Angle of view : 2/3"	56.9°×43.9°	39.3°×30.0°	30.8°×23.3°	20.0°×15.1°	14.7°×11.0°
Working Distance*1 [mm]	∞-100	∞-100	∞-100	∞-100	∞-200
Operation of focus	Manual	Manual	Manual	Manual	Manual
Operation of iris	Manual	Manual	Manual	Manual	Manual
Filter thread [mm]	M30.5×0.5	M30.5×0.5	M30.5×0.5	M30.5×0.5	M30.5×0.5
Mount	C-mount	C-mount	C-mount	C-mount	C-mount
Weight (approx.) [g]	95	85	90	85	85
Sensor size (std.)*2	2/3"(2.1μm)	2/3"(2.1μm)	2/3"(2.1μm)	2/3"(2.1μm)	2/3"(2.1μm)
Sensor size (max.)*3	2/3"(2.1μm)	1/1.2"(4.5μm)	1/1.2"(4.5μm)	1/1.2"(4.5μm)	1"(4.5μm)
TV distortion [%]	-1.03	0.18	-0.03	0.02	0.01
Dimension [mm]	ø33×48.5	ø33×52.5	ø33×52.5	ø33×53.1	ø33×53.1

HF818-12M

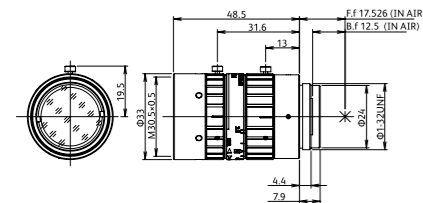

HF1218-12M

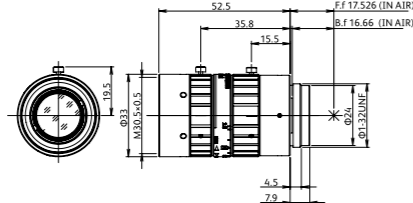

HF1618-12M

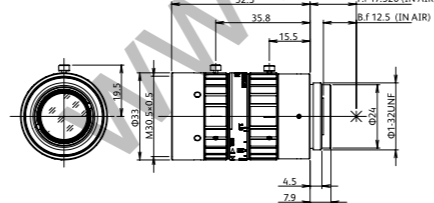

HF2518-12M

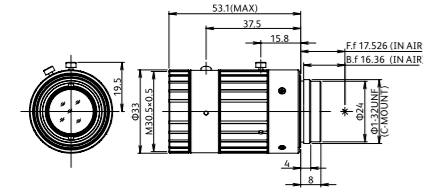

HF3520-12M

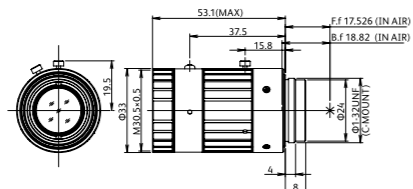

\*1 From front of lens barrel. \*2 Sensor size(std.): Ideal size to maximize the target resolution.  
\*3 Sensor size(max.): Adaptable sensor size varies depending on the model. Please check the amount of light and resolution on the edges pertaining to your particular application.

# HF-XA-5M series, 2/3"-1.1" \*3, 3.45μm, 5MP

Maximum sensor size: 6mm/8mm=2/3", 12mm/16mm/25mm/35mm=1/1.2", 50mm=1.1"



- Compact design



	Anti Shock & Vibration HF6XA-5M	HF8XA-5M	HF12XA-5M	HF16XA-5M	HF25XA-5M	HF35XA-5M	Anti Shock & Vibration HF50XA-5M
Focal length [mm]	6	8	12	16	25	35	50
Iris range [F. no]	F1.9-F16	F1.6-F16	F1.6-F16	F1.6-F16	F1.6-F16	F1.9-F16	F2.4-F16
Angle of view : 2/3"	74.7°×58.1°	58.4°×44.6°	40.1°×30.3°	31.4°×23.7°	20.0°×15.0°	14.2°×10.7°	10.4°×7.8°
Working Distance*1 [mm]	∞-100	∞-100	∞-100	∞-100	∞-100	∞-200	∞-200
Operation of focus	Manual	Manual	Manual	Manual	Manual	Manual	Manual
Operation of iris	Manual	Manual	Manual	Manual	Manual	Manual	Manual
Filter thread [mm]	M37.5×0.5	M25.5×0.5	M25.5×0.5	M25.5×0.5	M25.5×0.5	M25.5×0.5	M30.5×0.5
Mount	C-mount	C-mount	C-mount	C-mount	C-mount	C-mount	C-mount
Weight (approx.) [g]	100	79	79	71	72	60	95
Sensor size (std.)*2	2/3"(3.45μm)	2/3"(3.45μm)	2/3"(3.45μm)	2/3"(3.45μm)	2/3"(3.45μm)	2/3"(3.45μm)	2/3"(3.45μm)
Sensor size (max.)*3	2/3"(3.45μm)	2/3"(3.45μm)	1/1.2"(4.5μm)	1/1.2"(4.5μm)	1/1.2"(4.5μm)	1/1.2"(4.5μm)	1.1"(4.5μm)
TV distortion [%]	-2.88	-1.99	-1.26	-0.60	-0.07	0.10	0.01
Dimension [mm]	ø39×51	ø29.5×51.5	ø29.5×51.5	ø29.5×46	ø29.5×46.5	ø29.5×41.5	ø33×66.5

HF6XA-5M

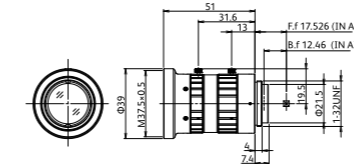

HF8XA-5M

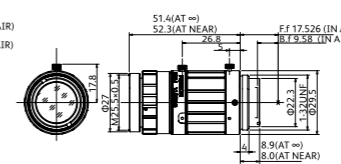

HF12XA-5M

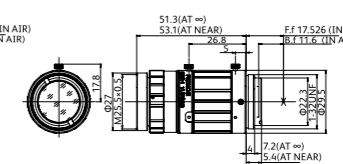

HF16XA-5M

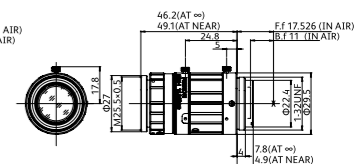

HF25XA-5M

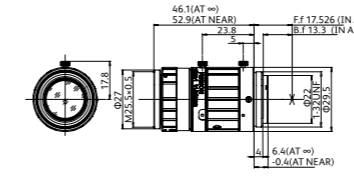

HF35XA-5M

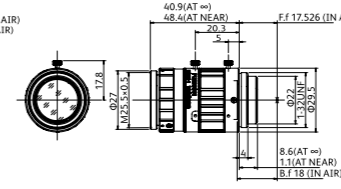

HF50XA-5M

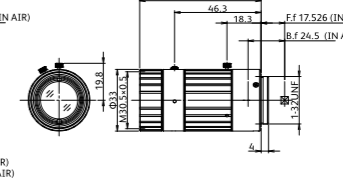

\*1 From front of lens barrel. \*2 Sensor size(std.): Ideal size to maximize the target resolution.  
\*3 Sensor size(max.): Adaptable sensor size varies depending on the model. Please check the amount of light and resolution on the edges pertaining to your particular application.

# HF-XA-1F series, 2/3"-1/1.2", 3.45μm, 5MP



- Compact design



## New anti-shock & vibration design

- Our unique mechanical design cutting the movable points realizes anti-shock & vibration performance.
- Because of no screw to fix the iris and focus position, HF-XA-1F can be used safely without any concerns of screw dropping.



	Anti Shock & Vibration HF8XA-1F	Anti Shock & Vibration HF12XA-1F	Anti Shock & Vibration HF16XA-1F	Anti Shock & Vibration HF25XA-1F	Anti Shock & Vibration HF35XA-1F
Focal length [mm]	8	12	16	25	35
Iris range [F. no]	F1.6, F4, F8 (Selection)	F1.6, F4, F8 (Selection)	F1.6, F4, F8 (Selection)	F1.6, F4.6, F9.2 (Selection)	F1.9, F5.2, F10.4 (Selection)
Angle of view : 2/3"	58.4°×44.6°	40.1°×30.3°	31.4°×23.7°	20.0°×15.0°	14.2°×10.7°
Working Distance*1 [mm]	∞-100	∞-100	∞-100	∞-150	∞-300
Operation of focus	Fixed	Fixed	Fixed	Fixed	Fixed
Operation of iris	Fixed	Fixed	Fixed	Fixed	Fixed
Filter thread [mm]	M25.5 x 0.5	M25.5 x 0.5	M25.5 x 0.5	M25.5 x 0.5	M25.5 x 0.5
Mount	C-mount	C-mount	C-mount	C-mount	C-mount
Weight (approx.) [g]	97	99	94	87	75
Sensor size (std.)*2	2/3"(3.45μm)	2/3"(3.45μm)	2/3"(3.45μm)	2/3"(3.45μm)	2/3"(3.45μm)
Sensor size (max.)*3	2/3"(3.45μm)	1/1.2"(4.5μm)	1/1.2"(4.5μm)	1/1.2"(4.5μm)	1/1.2"(4.5μm)
TV distortion [%]	-1.99	-1.26	-0.60	-0.07	0.10
Dimension [mm]	ø34×60.2	ø34×58.7	ø34×54.0	ø34×55.4	ø34×50.3
Required maximum screw-in length*4 [mm]	8.9	7.8	7.8	9.2	9.2

- Iris plates having different F.no. are included with package. These plates can enable us adjust the F.no. depending on the situation in the installation and the user's application.
- Because iris plates are inserted and fixed by the screw, there will be no change in the F.no. while the system is working under the severe situation.

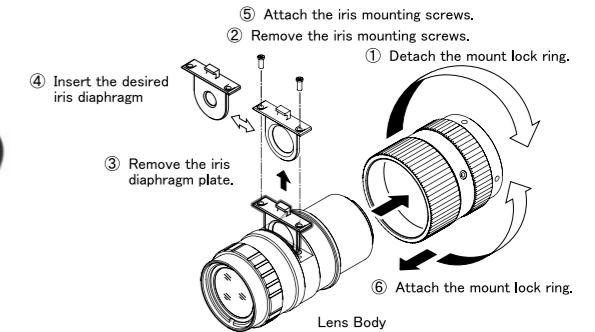

HF8XA-1F

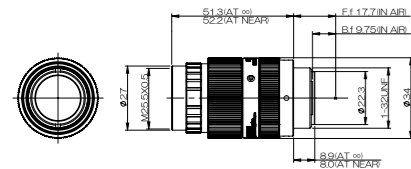

HF12XA-1F

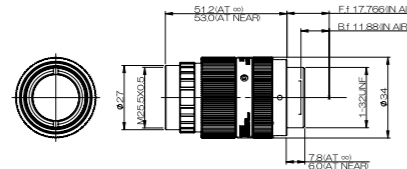

HF16XA-1F

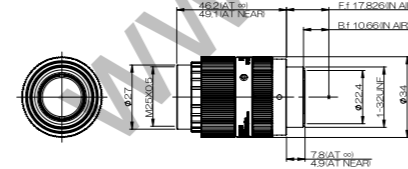

HF25XA-1F

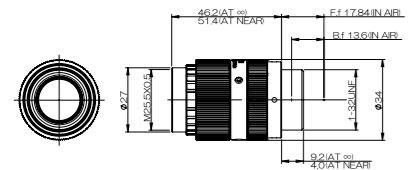

HF35XA-1F

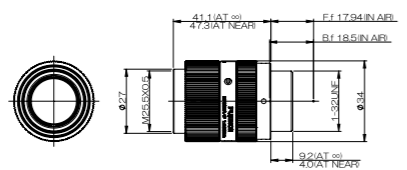

- There are 3 halls of M2.0 screw on the mechanical barrel. Because it can realize the strengthen of fixing, HF-XA-1F can be installed under the severe situation having the shock & vibrations.

\*1 From front of lens barrel. \*2 Sensor size(std.): Ideal size to maximize the target resolution.  
 \*3 Sensor size(max.): Adaptable sensor size varies depending on the model. Please check the amount of light and resolution on the edges pertaining to your particular application.  
 \*4 This is the maximum screw-in length required when the object distance is used with INF. Be sure to check this lens can be attached to your camera before purchase.

# HF-HA-1S series, 1/2"-2/3", 6.2μm, 1.5 MP



- Wide range of focal lengths with 8 models
- Compact design with an external diameter of 29.5mm\*
- Large maximum aperture
- Short Minimum Object Distance

\* HF75HA-1S has a diameter of 31.5mm



	Anti Shock & Vibration DF6HA-1S	Anti Shock & Vibration HF9HA-1S	Anti Shock & Vibration HF12.5HA-1S	Anti Shock & Vibration HF16HA-1S	Anti Shock & Vibration HF25HA-1S	Anti Shock & Vibration HF35HA-1S	Anti Shock & Vibration HF50HA-1S	Anti Shock & Vibration HF75HA-1S
Focal length [mm]	6	9	12.5	16	25	35	50	75
Iris range [F. no]	F1.2-F16	F1.4-F16	F1.4-F16	F1.4-F16	F1.4-F16	F1.6-F22	F2.3-F22	F2.8-F22
Angle of view	57.3°×43.8°(1/2")	53.3°×40.5°(2/3")	39.2°×29.4°(2/3")	30.5°×22.9°(2/3")	19.4°×14.6°(2/3")	14.3°×10.8°(2/3")	10.1°×7.6°(2/3")	6.7°×5.0°(2/3")
Working Distance*1 [mm]	∞-10	∞-40	∞-20	∞-40	∞-120	∞-230	∞-500	∞-1,100
Operation of focus	Manual	Manual	Manual	Manual	Manual	Manual	Manual	Manual
Operation of iris	Manual	Manual	Manual	Manual	Manual	Manual	Manual	Manual
Filter thread [mm]	M27×0.5	M27×0.5	M25.5×0.5	M25.5×0.5	M25.5×0.5	M25.5×0.5	M25.5×0.5	M30.5×0.5
Mount	C-mount	C-mount	C-mount	C-mount	C-mount	C-mount	C-mount	C-mount
Weight (approx.) [g]	50	50	40	40	40	40	40	50
Sensor size (std.)*2	1/2"(4.5μm)	2/3"(6.2μm)	2/3"(6.2μm)	2/3"(6.2μm)	2/3"(6.2μm)	2/3"(6.2μm)	2/3"(6.2μm)	2/3"(6.2μm)
Sensor size (max.)*3	1/2"(4.5μm)	2/3"(6.2μm)	2/3"(6.2μm)	2/3"(6.2μm)	2/3"(6.2μm)	2/3"(6.2μm)	2/3"(6.2μm)	2/3"(6.2μm)
TV distortion [%]	-1.84	-2.00	-1.95	-0.87	-0.19	0.10	0.06	0.36
Dimension [mm]	ø29.5×36.7	ø29.5×35	ø29.5×29.5	ø29.5×29.5	ø29.5×29.5	ø29.5×29.5	ø29.5×29.5	ø31.5×48

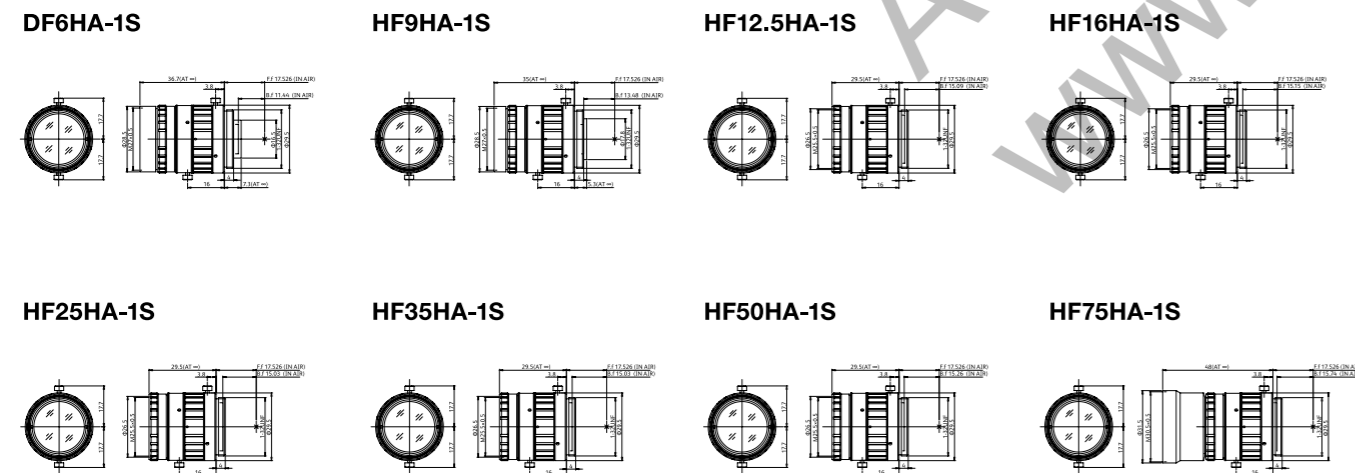

# HF-SA series, 2/3", 3.45μm, 5MP

- Low distortion
- Large maximum aperture



	HF12.5SA-1	HF16SA-1	HF25SA-1	HF35SA-1	HF50SA-1	HF75SA-1
Focal length [mm]	12.5	16	25	35	50	75
Iris range [F. no]	F1.4-F22	F1.4-F22	F1.4-F22	F1.4-F22	F1.8-F22	F1.8-F22
Angle of view : 2/3"	38.0°×29.0°	30.2°×22.9°	20.8°×15.7°	14.0°×10.5°	9.7°×7.3°	6.7°×5.0°
Working Distance*1 [mm]	∞-100	∞-100	∞-100	∞-200	∞-400	∞-900
Operation of focus	Manual	Manual	Manual	Manual	Manual	Manual
Operation of iris	Manual	Manual	Manual	Manual	Manual	Manual
Filter thread [mm]	M49×0.75	M49×0.75	M49×0.75	M49×0.75	M49×0.75	M49×0.75
Mount	C-mount	C-mount	C-mount	C-mount	C-mount	C-mount
Weight (approx.) [g]	295	285	315	185	240	305
Sensor size (std.)*2	2/3"(3.45μm)	2/3"(3.45μm)	2/3"(3.45μm)	2/3"(3.45μm)	2/3"(3.45μm)	2/3"(3.45μm)
Sensor size (max.)*3	2/3"(3.45μm)	2/3"(3.45μm)	2/3"(3.45μm)	2/3"(3.45μm)	2/3"(3.45μm)	2/3"(3.45μm)
TV distortion [%]	-0.08	0.11	-0.06	0.07	0.08	0.01
Dimension [mm]	ø51×68.5	ø51×70.5	ø51×75.5	ø51×48.5	ø51×55.5	ø51×76

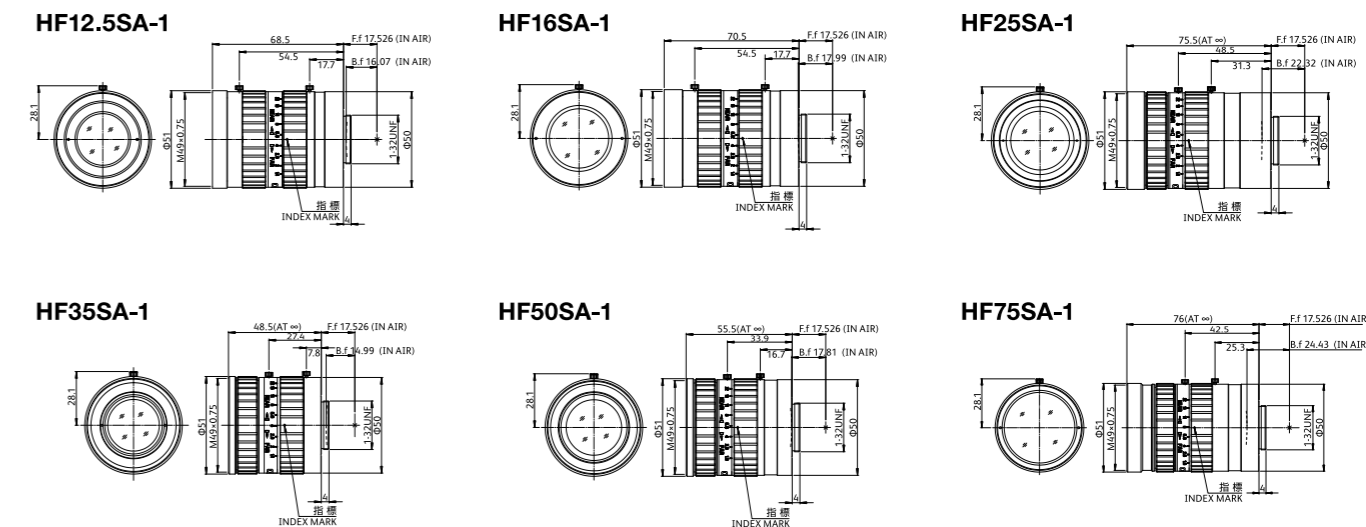

\*1 From front of lens barrel. \*2 Sensor size(std.): Ideal size to maximize the target resolution.  
\*3 Sensor size(max.): Adaptable sensor size varies depending on the model. Please check the amount of light and resolution on the edges pertaining to your particular application.

\*1 From front of lens barrel. \*2 Sensor size(std.): Ideal size to maximize the target resolution.  
\*3 Sensor size(max.): Adaptable sensor size varies depending on the model. Please check the amount of light and resolution on the edges pertaining to your particular application.

# CF-HA series, 1", 9.1μm, 1.5MP

- Low distortion
- Large maximum aperture



	CF12.5HA-1	CF16HA-1	CF25HA-1	CF35HA-1	CF50HA-1	CF75HA-1
Focal length [mm]	12.5	16	25	35	50	75
Iris range [F. no]	F1.4-F22	F1.4-F22	F1.4-F22	F1.4-F22	F1.8-F22	F1.8-F22
Angle of view : 1"	53.1°×41.2°	42.6°×32.8°	29.9°×22.7°	20.3°×15.3°	14.1°×10.6°	9.8°×7.3°
Working Distance*1 [mm]	∞-100	∞-100	∞-100	∞-200	∞-400	∞-900
Operation of focus	Manual	Manual	Manual	Manual	Manual	Manual
Operation of iris	Manual	Manual	Manual	Manual	Manual	Manual
Filter thread [mm]	M49×0.75	M49×0.75	M49×0.75	M49×0.75	M49×0.75	M49×0.75
Mount	C-mount	C-mount	C-mount	C-mount	C-mount	C-mount
Weight (approx.) [g]	290	280	310	180	235	300
Sensor size (std.)*2	1"(9.1μm)	1"(9.1μm)	1"(9.1μm)	1"(9.1μm)	1"(9.1μm)	1"(9.1μm)
Sensor size (max.)*3	1"(9.1μm)	1"(9.1μm)	1"(9.1μm)	1"(9.1μm)	1"(9.1μm)	1"(9.1μm)
TV distortion [%]	0.86	0.79	0.36	0.18	0.20	0.01
Dimension [mm]	ø51×68.5	ø51×70.5	ø51×75.5	ø51×48.5	ø51×55.5	ø51×76

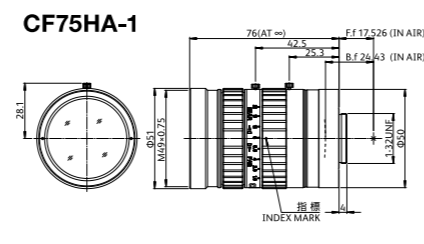
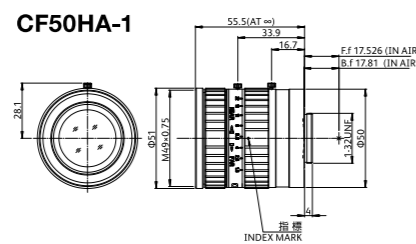
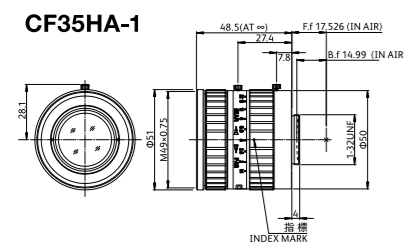
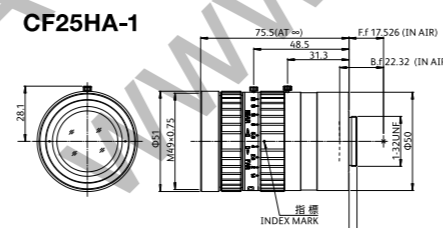
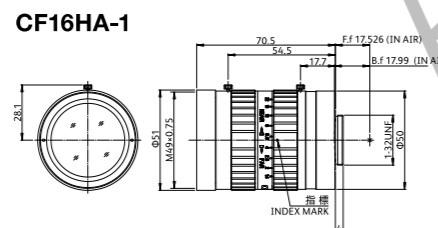
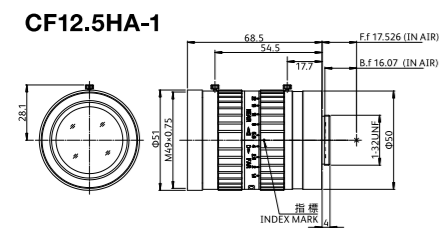

\*1 From front of lens barrel. \*2 Sensor size(std.): Ideal size to maximize the target resolution.  
\*3 Sensor size(max.): Adaptable sensor size varies depending on the model. Please check the amount of light and resolution on the edges pertaining to your particular application.

# FE185 series Fisheye lens

- Super wide-angle with a 185° field of view
- 2 models for 1" and 2/3"
- Supporting 5 MP sensor



	FE185C086HA-1	FE185C057HA-1
Focal length [mm]	2.7	1.8
Iris range [F. no]	F1.8-F16	F1.4-F16
Angle of view : 1"	185.0°×185.0°(ø8.6mm)	185.0°×185.0°(ø5.7mm)
Angle of view : 2/3"	185.0°×140.6°	185.0°×154.1°
Angle of view : 1/2"	136.3°×102.3°	154.1°×115.4°
Working Distance*1 [mm]	∞-200	∞-100
Operation of focus	Fixed	Fixed
Operation of iris	Manual	Manual
Mount	C-mount	C-mount
Weight (approx.) [g]	160	135
Sensor size (std.)*2	-	-
Sensor size (max.)*3	1"(5μm)	2/3"(3.45μm)
Dimension [mm]	ø56.5×60.5	ø56.5×60.3

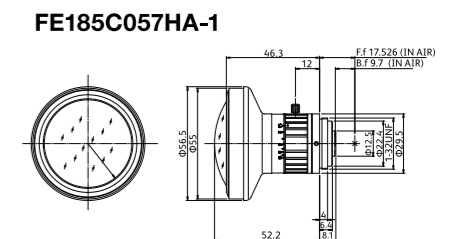
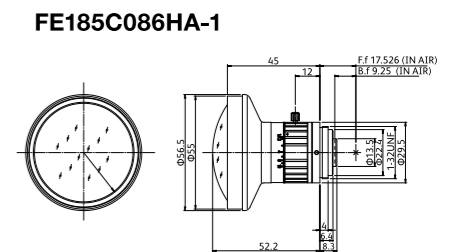

## Simulation images

FE185C086HA-1



1" sensors



2/3" sensors

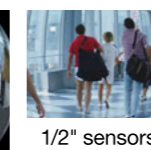

1/2" sensors

FE185C057HA-1

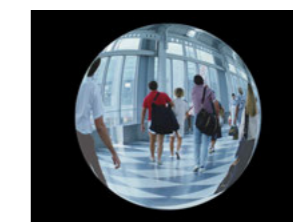

2/3" sensors



1/2" sensors



1/3" sensors

\*1 From front of lens. \*2 Sensor size(std.): Ideal size to maximize the target resolution.  
\*3 Sensor size(max.): Adaptable sensor size varies depending on the model. Please check the amount of light and resolution on the edges pertaining to your particular application.

# FUJINON Lens Shooting Range Chart

## CF-ZA-1S series

### CF8ZA-1S

Working Distance [mm]	Optical Magnification	Extension Tube [mm]	Field of View [mm]											
			1.2"		1.1"		1"		2/3"		1/2"			
			H	V	H	V	H	V	H	V	H	V		
1000	0.008x	-	2106.6	1499.9	1885.2	1355.9	1684.7	1221.8	1112.6	822.2				
950	0.009x	-	2002.9	1426	1792.4	1289.1	1601.8	1161.6	1057.8	781.7				
900	0.009x	-	1899.2	1352.2	1699.6	1222.3	1518.8	1101.4	1003	741.2				
850	0.010x	-	1795.5	1278.3	1606.8	1155.5	1435.9	1041.2	948.2	700.7				
800	0.010x	-	1691.8	1204.4	1514	1088.7	1352.9	981	893.4	660.2				
750	0.011x	-	1588.2	1130.6	1421.2	1021.9	1269.9	920.9	838.6	619.7				
700	0.012x	-	1484.5	1056.7	1328.4	955.2	1187	860.7	783.7	579.1				
650	0.013x	-	1380.8	982.8	1235.6	888.4	1104	800.5	728.9	538.6				
600	0.014x	-	1277.1	909	1142.7	821.6	1021.1	740.3	674.1	498.1				
550	0.015x	-	1173.4	835.1	1049.9	754.8	938.1	680.1	619.3	457.6				
500	0.016x	-	1069.7	761.2	957.1	688	855.2	619.9	564.5	417.1				
450	0.018x	-	966	687.4	864.3	621.3	772.2	559.8	509.7	376.6				
400	0.020x	-	862.3	613.5	771.5	554.5	689.2	499.6	454.9	336.1				
350	0.023x	-	758.6	539.6	678.6	487.7	606.3	439.4	400.1	295.6				
300	0.026x	-	654.9	465.7	585.8	420.9	523.3	379.2	345.2	255				
250	0.031x	-	551.2	391.8	493	354.1	440.3	319	290.4	214.5				
200	0.039x	-	447.5	318	400.2	287.3	357.3	258.8	235.6	174				
150	0.050x	-	343.8	244.1	307.3	220.5	274.4	198.6	180.8	133.5				
100	0.073x	-	240	170.1	214.4	153.7	191.3	138.4	125.9	92.9				

### CF12ZA-1S

Working Distance [mm]	Optical Magnification	Extension Tube [mm]	Field of View [mm]											
			1.2"		1.1"		1"		2/3"		1/2"			
			H	V	H	V	H	V	H	V	H	V		
1000	0.012x	-	1369.9	995.1	1236.5	902.4	1112.2	815.2	743.6	551.4				
950	0.013x	-	1302.7	946.2	1175.8	858.1	1057.6	775.1	707.1	524.3				
900	0.013x	-	1235.5	897.4	1115.2	813.8	1003	735.1	670.6	497.2				
850	0.014x	-	1168.3	848.5	1054.5	769.4	948.4	695.1	634.1	470.2				
800	0.015x	-	1101.1	799.7	993.8	725.1	893.8	655	597.5	443.1				
750	0.016x	-	1033.9	750.8	933.1	680.8	839.3	615	561	416				
700	0.017x	-	966.7	702	872.5	636.5	784.7	575	524.5	388.9				
650	0.019x	-	899.5	653.1	811.8	592.2	730.1	535	488	361.8				
600	0.020x	-	832.3	604.3	751.1	547.9	675.5	494.9	451.5	334.7				
550	0.022x	-	765.1	555.4	690.4	503.6	620.9	454.9	414.9	307.6				
500	0.024x	-	697.9	506.6	629.7	459.3	566.3	414.9	378.4	280.6				
450	0.026x	-	630.7	457.7	569.1	415	511.7	374.8	341.9	253.5				
400	0.030x	-	563.5	408.8	508.4	370.7	457.1	334.8	305.4	226.4				
350	0.034x	-	496.2	360	447.7	326.3	402.5	294.7	268.8	199.3				
300	0.039x	-	429	311.1	387	282	347.9	254.7	232.3	172.2				
250	0.046x	-	361.7	262.2	326.2	237.7	293.2	214.6	195.7	145.1				
200	0.057x	-	294.5	213.3	265.5	193.3	238.6	174.6	159.2	118				
150	0.074x	-	227.1	164.4	204.7	148.9	183.9	134.5	122.6	90.8				
100	0.105x	-	159.7	115.3	143.8	104.5	129.1	94.3	86	63.7				

### CF16ZA-1S

Working Distance [mm]	Optical Magnification	Extension Tube [mm]	Field of View [mm]											
			1.2"		1.1"		1"		2/3"		1/2"			
			H	V	H	V	H	V	H	V	H	V		
1000	0.016x	-	983.5	730.2	895.1	665.3	811	603.4	552.2	412.4				
950	0.017x	-	935.4	694.5	851.3	632.7	771.3	573.9	525.1	392.2				
900	0.018x	-	887.3	658.7	807.5	600.1	731.6	544.3	498.1	372				
850	0.019x	-	839.2	622.9	763.7	567.5	691.9	514.8	471	351.8				
800	0.020x	-	791.1	587.2	719.9	535	652.2	485.2	444	331.6				
750	0.021x	-	743	551.4	676.1	502.4	612.5	455.7	416.9	311.4				
700	0.023x	-	694.9	515.7	632.3	469.8	572.8	426.1	389.9	291.2				
650	0.025x	-	646.8	479.9	588.5	437.2	533.1	396.5	362.8	271				
600	0.026x	-	598.6	444.2	544.7	404.6	493.4	367	335.8	250.7				
550	0.029x	-	550.5	408.4	500.9	372	453.7	337.4	308.7	230.5				
500	0.032x	-	502.4	372.6	457	339.4	414	307.8	281.7	210.3				
450	0.035x	-	454.2	336.9	413.2	306.8	374.2	278.3	254.6	190.1				
400	0.039x	-	406.1	301.1	369.4	274.2	334.5	248.7	227.5	169.9				
350	0.044x	-	357.9	265.3	325.5	241.6	294.8	219.1	200.5	149.6				
300	0.051x	-	309.7	229.5	281.7	209	255	189.5	173.4	129.4				
250	0.061x	-	261.5	193.7	237.8	176.4	215.2	159.9	146.3	109.2				
200	0.075x	-	213.2	157.8	193.8	143.7	175.4	130.2	119.1	88.9				
150	0.097x	-	164.9	121.9	149.8	110.9	135.5	100.6	92	68.6				
100	0.138x	-	116.3	85.8	105.6	78.1	95.4	70.7	64.7	48.2				

### CF25ZA-1S

Working Distance [mm]	Optical Magnification	Extension Tube [mm]	Field of View [mm]											
			4/3"		1.2"		1.1"		1"		2/3"			
			H	V	H	V	H	V	H	V	H	V		
1000	0.024x	-	780.1	577.8	663.1	492.7	603.5	449	546.9	407.5	373	278.9		
950	0.025x	-	742	549.5	630.7	468.5	574	427	520.1	387.5	354.7	265.2		
900	0.026x	-	703.8	521.2	598.2	444.4	544.4	405	493.4	367.6	336.5	251.5		
850	0.028x	-	665.6	492.9	565.7	420.3	514.9	383.1	466.6	347.6	318.2	237.9		
800	0.030x	-	627.5	464.6	533.3	396.1	485.3	361.1	439.8	327.6	299.9	224.2		
750	0.031x	-	589.3	436.3	500.8	372	455.8	339.1	413	307.7	281.6	210.5		
700	0.034x	-	551.1	408	468.3	347.9	426.2	317.1	386.2	287.7	263.4	196.9		
650	0.036x	-	512.9	379.7	435.9	323.7	396.6	295.1	359.4	267.7	245.1	183.2		
600	0.039x	-	474.7	351.4	403.4	299.6	367.1	273	332.6	247.8	226.8	169.5		
550	0.043x	-	436.5	323.1	370.9	275.4	337.5	251	305.8	227.8	208.5	155.9		
500	0.047x	-	398.3	294.8	338.4	251.3	307.9	229	279	207.8	190.2	142.2		
450	0.052x	-	360.1	266.4	305.9	227.1	278.3	207	252.2	187.8	171.9	128.5		
400	0.058x	-	321.8	238.1	273.4	202.9	248.7	184.9	225.3	167.8	153.6	114.8		
350	0.066x	-	283.6	209.7	240.8	178.7	219.1	162.9	198.5	147.8	135.3	101.1		
300	0.076x	-	245.2	181.3	208.2	154.5	189.4	140.8	171.6	127.7	116.9	87.4		
250	0.090x	-	206.8	152.8	175.5	130.2	159.7	118.6	144.6	107.6	98.5	73.8		
200	0.111x	-	168.3	124.3	142.8	105.9	129.8	96.4	117.6	87.5	80.1	59.8		
150	0.144x	-	129.5	95.5	109.8	81.3	99.8	74.1	90.4	67.2	61.5	46		
100	0.208x	-	90.2	66.4	76.3	56.5	69.4	51.4	62.8	46.6	42.7	31.9		

### CF35ZA-1S

Working Distance [mm]	Optical Magnification	Extension Tube [mm]	Field of View [mm]											
			4/3"		1.2"		1.1"		1"		2/3"			
			H	V	H	V	H	V	H	V	H	V		
1000	0.034x	-	541.2	403.7	462	345	421.3	314.9	382.5	286	262	196.2		
950	0.036x	-	515	384.1	439.6	328.3	400.9	299.6	363.9	272.1	249.3	186.7		
900	0.038x	-	488.8	364.6	417.2	311.6	380.5	284.3	345.4	258.3	236.6	177.2		
850	0.040x	-	462.6	345	394.8	294.9	360.1	269.1	326.9	244.4	223.9	167.7		
800	0.042x	-	436.4	325.4	372.5	278.1	339.6	253.8	308.3	230.5	211.2	158.2		
750	0.045x	-	410.2	305.9	350.1	261.4	319.2	238.5	289.8	216.7	198.5	148.6		
700	0.048x	-	384	286.3	327.7	244.7	298.8	223.3	271.2	202.8	185.8	139.1		
650	0.051x	-	357.7	266.7	305.3	227.9	278.4	208	252.7	188.9	173.1	129.6		
600	0.056x	-	331.5	247.1	282.9	211.2	257.9	192.7	234.1	175	160.3			

## HF-XA-5M / HF-XA-1F series

### HF6XA-5M

Working Distance [mm]	Optical Magnification	Extension Tube [mm]	Field of View [mm]					
			2/3"		1/2"		1/3"	
			H	V	H	V	H	V
1000	0.006x	-	1548.2	1126.4	1089.5	802.1	802.1	594.9
950	0.006x	-	1471.8	1070.9	1035.7	762.5	762.5	565.6
900	0.007x	-	1395.5	1015.3	982.0	722.9	722.9	536.3
850	0.007x	-	1319.1	959.8	928.3	683.4	683.4	506.9
800	0.008x	-	1242.8	904.2	874.6	643.8	643.8	477.6
750	0.008x	-	1166.5	848.7	820.8	604.3	604.3	448.2
700	0.009x	-	1090.1	793.1	767.1	564.7	564.7	418.9
650	0.009x	-	1013.8	737.6	713.4	525.2	525.2	389.6
600	0.010x	-	937.4	682.0	659.6	485.6	485.6	360.2
550	0.011x	-	861.1	626.5	605.9	446.1	446.1	330.9
500	0.012x	-	784.8	570.9	552.2	406.5	406.5	301.5
450	0.013x	-	708.4	515.4	498.5	367.0	367.0	272.2
400	0.015x	-	632.1	459.8	444.7	327.4	327.4	242.9
350	0.017x	-	555.7	404.3	391.0	287.8	287.8	213.5
300	0.020x	-	479.4	348.7	337.3	248.3	248.3	184.2
250	0.024x	-	403.0	293.2	283.5	208.7	208.7	154.8
200	0.029x	-	326.7	237.6	229.8	169.2	169.2	125.5
150	0.038x	-	250.4	182.1	176.1	129.6	129.6	96.2
100	0.055x	-	174.0	126.5	122.4	90.1	90.1	66.8

### HF8XA-5M / HF8XA-1F

Working Distance [mm]	Optical Magnification	Extension Tube [mm]	Field of View [mm]					
			2/3"		1/2"		1/3"	
			H	V	H	V	H	V
1000	0.008x	-	1130.4	830.5	803.9	595.5	595.5	443.3
950	0.009x	-	1074.6	789.5	764.2	566.1	566.1	421.4
900	0.009x	-	1018.8	748.5	724.5	536.6	536.6	399.5
850	0.010x	-	962.9	707.4	684.8	507.2	507.2	377.6
800	0.010x	-	907.1	666.4	645.1	477.8	477.8	355.7
750	0.011x	-	851.2	625.4	605.4	448.4	448.4	333.8
700	0.012x	-	795.4	584.3	565.7	419.0	419.0	311.9
650	0.013x	-	739.6	543.3	525.9	389.6	389.6	290.0
600	0.014x	-	683.7	502.3	486.2	360.1	360.1	268.1
550	0.015x	-	627.9	461.3	446.5	330.7	330.7	246.2
500	0.016x	-	572.0	420.2	406.8	301.3	301.3	224.3
450	0.018x	-	516.2	379.2	367.1	271.9	271.9	202.4
400	0.020x	-	460.3	338.2	327.4	242.5	242.5	180.5
350	0.023x	-	404.5	297.1	287.6	213.0	213.0	158.6
300	0.027x	-	348.7	256.1	247.9	183.6	183.6	136.7
250	0.032x	-	292.8	215.1	208.2	154.2	154.2	114.8
200	0.039x	-	237.0	174.1	168.5	124.8	124.8	92.9
150	0.051x	-	181.1	133.0	128.8	95.4	95.4	71.0
100	0.074x	-	125.3	92.0	89.1	66.0	66.0	49.1

### HF12XA-5M / HF12XA-1F

Working Distance [mm]	Optical Magnification	Extension Tube [mm]	Field of View [mm]					
			1/1.2"		2/3"		1/2"	
			H	V	H	V	H	V
1000	0.012x	-	913.0	673.6	740.5	548.9	531.8	396.2
950	0.013x	-	868.0	640.4	704.0	521.9	505.6	376.7
900	0.014x	-	823.0	607.2	667.5	494.8	479.4	357.2
850	0.014x	-	778.0	574.0	631.0	467.8	453.2	337.7
800	0.015x	-	733.0	540.8	594.5	440.7	427.0	318.1
750	0.016x	-	688.0	507.6	558.0	413.7	400.8	298.6
700	0.017x	-	643.1	474.5	521.6	386.6	374.6	279.1
650	0.019x	-	598.1	441.3	485.1	359.6	348.3	259.6
600	0.020x	-	553.1	408.1	448.6	332.5	322.1	240.0
550	0.022x	-	508.1	374.9	412.1	305.5	295.9	220.5
500	0.024x	-	463.1	341.7	375.6	278.4	269.7	201.0
450	0.027x	-	418.2	308.5	339.1	251.4	243.5	181.5
400	0.030x	-	373.2	275.3	302.6	224.3	217.3	161.9
350	0.034x	-	328.2	242.1	266.2	197.3	191.1	142.4
300	0.039x	-	283.2	208.9	229.7	170.2	164.9	122.9
250	0.047x	-	238.2	175.7	193.2	143.2	138.7	103.4
200	0.058x	-	193.2	142.5	156.7	116.1	112.5	83.8
150	0.075x	-	148.3	109.3	120.2	89.1	86.3	64.3
100	0.108x	-	103.3	76.1	83.7	62.0	60.1	44.8

### HF16XA-5M / HF16XA-1F

Working Distance [mm]	Optical Magnification	Extension Tube [mm]	Field of View [mm]					
			1/1.2"		2/3"		1/2"	
			H	V	H	V	H	V
1000	0.016x	-	701.9	522.1	572.8	427.0	413.9	309.3
950	0.016x	-	667.5	496.5	544.7	406.0	393.6	294.2
900	0.017x	-	633.1	470.9	516.6	385.1	373.2	279.0
850	0.018x	-	598.7	445.3	488.4	364.1	352.9	263.8
800	0.019x	-	564.2	419.7	460.3	343.2	332.6	248.6
750	0.021x	-	529.8	394.0	432.2	322.2	312.3	233.4
700	0.022x	-	495.4	368.4	404.1	301.3	292.0	218.2
650	0.024x	-	461.0	342.8	376.0	280.3	271.7	203.0
600	0.026x	-	426.5	317.2	347.9	259.3	251.4	187.9
550	0.028x	-	392.1	291.5	319.8	238.4	231.0	172.7
500	0.031x	-	357.7	265.9	291.7	217.4	210.7	157.5
450	0.034x	-	323.3	240.3	263.6	196.5	190.4	142.3
400	0.038x	-	288.8	214.7	235.5	175.5	170.1	127.1
350	0.043x	-	254.4	189.1	207.4	154.6	149.8	111.9
300	0.050x	-	220.0	163.4	179.3	133.6	129.5	96.7
250	0.059x	-	185.6	137.8	151.2	112.6	109.2	81.6
200	0.073x	-	151.1	112.2	123.1	91.7	88.9	66.4
150	0.094x	-	116.7	86.6	95.0	70.7	68.5	51.2
100	0.134x	-	82.3	60.9	66.9	49.8	48.2	36.0

### HF25XA-5M / HF25XA-1F

Working Distance [mm]	Optical Magnification	Extension Tube [mm]	Field of View [mm]					
			1/1.2"		2/3"		1/2"	
			H	V	H	V	H	V
1000	0.025x	-	435.9	326.5	357.4	267.8	259.7	194.6
950	0.026x	-	414.4	310.4	339.9	254.6	246.9	185.1
900	0.027x	-	393.0	294.3	322.3	241.5	234.1	175.5
850	0.029x	-	371.5	278.3	304.7	228.3	221.3	165.9
800	0.031x	-	350.1	262.2	287.1	215.1	208.6	156.3
750	0.033x	-	328.7	246.1	269.5	201.9	195.8	146.7
700	0.035x	-	307.2	230.1	251.9	188.7	183.0	137.2
650	0.038x	-	285.8	214.0	234.3	175.6	170.2	127.6
600	0.041x	-	264.4	198.0	216.8	162.4	157.4	118.0
550	0.044x	-	242.9	181.9	199.2	149.2	144.7	108.4
500	0.049x	-	221.5	165.8	181.6	136.0	131.9	98.8
450	0.054x	-	200.1	149.8	164.0	122.8	119.1	89.3
400	0.060x	-	178.6	133.7	146.4	109.7	106.3	79.7
350	0.069x	-	157.2	117.6	128.8	96.5	93.5	70.1
300	0.079x	-	135.7	101.6	111.2	83.3	80.8	60.5
250	0.094x	-	114.3	85.5	93.7	70.1	68.0	50.9
200	0.116x	-	92.9	69.4	76.1	56.9	55.2	41.4
150	0.151x	-	71.4	53.4	58.5	43.7	42.4	31.8
100	0.217x	-/1.5	49.9	37.3	40.9	30.6	29.6	22.2

### HF35XA-5M / HF35XA-1F

Working Distance [mm]	Optical Magnification	Extension Tube [mm]	Field of View [mm]					
			1/1.2"		2/3"		1/2"	
			H	V	H	V	H	V
1000	0.035x	-	307.4	230.7	252.4	189.4	183.7	137.8
950	0.037x	-	292.1	219.3	240.0	180.0	174.6	131.0
900	0.039x	-	276.9	207.8	227.5	170.7	165.5	124.1
850	0.041x	-	261.7	196.4	215.0	161.3	156.4	117.3
800	0.044x	-	246.5	185.0	202.5	151.9	147.3	110.5
750	0.047x	-	231.3	173.6	190.0	142.5	138.2	103.7
700	0.050x	-	216.1	162.2	177.5	133.1	129.1	96.8
650	0.054x	-	200.9	150.8	165.0	123.8	120.0	90.0
600	0.059x	-	185.7	139.3	152.5	114.4	110.9	83.2
550	0.064x	-	170.5	127.9	140.0	105.0	101.8	76.4
500	0.070x	-	155.3	116.5	127.5	95.6	92.7	69.6
450	0.078x	-	140.1	105.1	115.0	86.3	83.6	62.7
400	0.088x	-	124.9	93.7	102.5	76.9	74.6	55.9
350	0.101x	-	109.7	82.2	90.0	67.5	65.5	49.1
300	0.117x	-	94.5	70.8	77.5	58.1	56.4	42.3
250	0.141x	-/0.5	79.3	59.4	65.0	48.8	47.3	35.5
200	0.176x	-/2	64.1	48.0	52.6	39.4	38.2	28.6
150	0.235x	2/5	48.3	36.2	39.6	29.7	28.8	21.6
100	0.354x	10/10	30.4	22.8	25.0	18.7	18.1	13.6

### HF50XA-5M

Working Distance [mm]	Optical Magnification	Extension Tube [mm]	Field of View [mm]					
			1.1"		2/3"		1/2"	
			H	V	H	V	H	V
1000	0.048x	-	293.1	219.7	183.1	137.3	133.1	99.8
950	0.051x	-	278.6	208.9	174.0	130.5	126.5	94.9
900	0.053x	-	264.1	198.0	164.9	123.7	119.9	89.9
850	0.056x	-	249.6	187.1	155.9	116.9	113.3	85.0
800	0.060x	-	235.1	176.2	146.8	110.1	106.7	80.0
750								

# HF-SA series

## HF12.5SA-1

Working Distance [mm]	Optical Magnification	Extension Tube [mm]	Field of View [mm]					
			2/3"		1/2"		1/3"	
			H	V	H	V	H	V
1000	0.013x	-	705.4	528.0	511.9	383.3	383.3	287.2
950	0.013x	-	670.9	502.2	486.9	364.6	364.6	273.2
900	0.014x	-	636.4	476.4	461.8	345.8	345.8	259.1
850	0.015x	-	601.9	450.5	436.8	327.1	327.1	245.1
800	0.016x	-	567.5	424.7	411.8	308.3	308.3	231.0
750	0.017x	-	533.0	398.9	386.7	289.6	289.6	217.0
700	0.018x	-	498.5	373.1	361.7	270.8	270.8	202.9
650	0.019x	-	464.1	347.3	336.7	252.1	252.1	188.9
600	0.021x	-	429.6	321.5	311.7	233.3	233.3	174.8
550	0.022x	-	395.1	295.6	286.6	214.6	214.6	160.8
500	0.025x	-	360.6	269.8	261.6	195.8	195.8	146.7
450	0.027x	-	326.2	244.0	236.6	177.1	177.1	132.7
400	0.030x	-	291.7	218.2	211.5	158.3	158.3	118.6
350	0.034x	-	257.2	192.4	186.5	139.6	139.6	104.6
300	0.040x	-	222.8	166.6	161.5	120.8	120.8	90.5
250	0.047x	-	188.3	140.7	136.4	102.1	102.1	76.5
200	0.058x	-	153.8	114.9	111.4	83.4	83.4	62.4
150	0.075x	-	119.3	89.1	86.4	64.6	64.6	48.4
100	0.105x	-	84.9	63.3	61.3	45.9	45.9	34.3

## HF16SA-1

Working Distance [mm]	Optical Magnification	Extension Tube [mm]	Field of View [mm]					
			2/3"		1/2"		1/3"	
			H	V	H	V	H	V
1000	0.016x	-	556.0	416.9	404.3	303.1	303.1	227.2
950	0.017x	-	529.1	396.7	384.7	288.4	288.4	216.2
900	0.018x	-	502.1	376.5	365.1	273.7	273.7	205.2
850	0.019x	-	475.2	356.3	345.5	259.0	259.0	194.2
800	0.020x	-	448.2	336.0	325.8	244.3	244.3	183.1
750	0.021x	-	421.3	315.8	306.2	229.6	229.6	172.1
700	0.022x	-	394.3	295.6	286.6	214.8	214.8	161.1
650	0.024x	-	367.4	275.4	267.0	200.1	200.1	150.0
600	0.026x	-	340.4	255.2	247.4	185.4	185.4	139.0
550	0.028x	-	313.5	234.9	227.8	170.7	170.7	128.0
500	0.031x	-	286.5	214.7	208.2	156.0	156.0	117.0
450	0.034x	-	259.6	194.5	188.6	141.3	141.3	105.9
400	0.038x	-	232.6	174.3	169.0	126.6	126.6	94.9
350	0.043x	-	205.7	154.0	149.4	111.9	111.9	83.9
300	0.049x	-	178.7	133.8	129.7	97.2	97.2	72.8
250	0.058x	-	151.8	113.6	110.1	82.5	82.5	61.8
200	0.071x	-	124.8	93.4	90.5	67.8	67.8	50.8
150	0.091x	-	97.9	73.1	70.9	53.1	53.1	39.8
100	0.126x	-	70.9	52.9	51.3	38.4	38.4	28.7

## HF25SA-1

Working Distance [mm]	Optical Magnification	Extension Tube [mm]	Field of View [mm]					
			2/3"		1/2"		1/3"	
			H	V	H	V	H	V
1000	0.023x	-	378.4	283.4	274.8	205.9	205.9	154.4
950	0.025x	-	360.0	269.6	261.4	195.9	195.9	148.8
900	0.026x	-	341.6	255.9	248.1	185.9	185.9	139.3
850	0.027x	-	323.2	242.1	234.7	175.9	175.9	131.8
800	0.029x	-	304.9	228.3	221.4	165.9	165.9	124.3
750	0.031x	-	286.5	214.5	208.0	155.9	155.9	116.8
700	0.033x	-	268.1	200.8	194.7	145.8	145.8	109.3
650	0.035x	-	249.7	187.0	181.3	135.8	135.8	101.8
600	0.038x	-	231.3	173.2	167.9	125.8	125.8	94.3
550	0.042x	-	212.9	159.4	154.6	115.8	115.8	86.8
500	0.045x	-	194.6	145.7	141.2	105.8	105.8	79.3
450	0.050x	-	176.2	131.9	127.9	95.8	95.8	71.8
400	0.056x	-	157.8	118.1	114.5	85.8	85.8	64.3
350	0.063x	-	139.4	104.3	101.1	75.8	75.8	56.8
300	0.073x	-	121.0	90.5	87.8	65.7	65.7	49.3
250	0.086x	-	102.6	76.8	74.4	55.7	55.7	41.8
200	0.105x	-	84.2	63.0	61.1	45.7	45.7	34.3
150	0.135x	-	65.9	49.2	47.7	35.7	35.7	26.8
100	0.187x	-	47.5	35.4	34.3	25.7	25.7	19.2

## HF35SA-1

Working Distance [mm]	Optical Magnification	Extension Tube [mm]	Field of View [mm]					
			2/3"		1/2"		1/3"	
			H	V	H	V	H	V
1000	0.035x	-	249.2	186.9	181.2	135.9	135.9	101.9
950	0.037x	-	236.9	177.6	172.2	129.2	129.2	96.9
900	0.039x	-	224.6	168.4	163.3	122.5	122.5	91.8
850	0.041x	-	212.3	159.2	154.3	115.7	115.7	86.8
800	0.044x	-	200.0	149.9	145.4	109.0	109.0	81.8
750	0.047x	-	187.7	140.7	136.4	102.3	102.3	76.7
700	0.050x	-	175.4	131.5	127.5	95.6	95.6	71.7
650	0.054x	-	163.1	122.2	118.5	88.9	88.9	66.7
600	0.058x	-	150.8	113.0	109.6	82.2	82.2	61.6
550	0.064x	-	138.5	103.8	100.6	75.5	75.5	56.6
500	0.070x	-	126.2	94.6	91.7	68.7	68.7	51.5
450	0.077x	-	113.9	85.3	82.7	62.0	62.0	46.5
400	0.087x	-	101.6	76.1	73.8	55.3	55.3	41.5
350	0.099x	-	89.3	66.9	64.8	48.6	48.6	36.4
300	0.115x	-	76.9	57.6	55.9	41.9	41.9	31.4
250	0.137x	-	64.6	48.4	46.9	35.2	35.2	26.4
200	0.169x	-	52.3	39.2	38.0	28.4	28.4	21.3
150	0.221x	2	40.0	29.9	29.0	21.7	21.7	16.3
100	0.320x	10	27.6	20.7	20.0	15.0	15.0	11.2

## HF50SA-1

Working Distance [mm]	Optical Magnification	Extension Tube [mm]	Field of View [mm]					
			2/3"		1/2"		1/3"	
			H	V	H	V	H	V
1500	0.034x	-	255.5	191.6	185.8	139.4	139.4	104.5
1450	0.036x	-	247.0	185.3	179.7	134.8	134.8	101.1
1400	0.037x	-	238.5	178.9	173.5	130.1	130.1	97.6
1350	0.038x	-	230.0	172.5	167.3	125.5	125.5	94.1
1300	0.040x	-	221.5	166.1	161.1	120.8	120.8	90.6
1250	0.041x	-	213.0	159.8	154.9	116.2	116.2	87.1
1200	0.043x	-	204.5	153.4	148.7	111.6	111.6	83.7
1150	0.045x	-	196.0	147.0	142.6	106.9	106.9	80.2
1100	0.047x	-	187.5	140.6	136.4	102.3	102.3	76.7
1050	0.049x	-	179.0	134.3	130.2	97.6	97.6	73.2
1000	0.052x	-	170.5	127.9	124.0	93.0	93.0	69.7
950	0.054x	-	162.0	121.5	117.8	88.4	88.4	66.3
900	0.057x	-	153.5	115.1	111.6	83.7	83.7	62.8
850	0.061x	-	145.0	108.7	105.4	79.1	79.1	59.3
800	0.064x	-	136.5	102.4	99.3	74.4	74.4	55.8
750	0.069x	-	128.0	96.0	93.1	69.8	69.8	52.3
700	0.074x	-	119.5	89.6	86.9	65.2	65.2	48.9
650	0.079x	-	111.0	83.2	80.7	60.5	60.5	45.4
600	0.086x	-	102.5	76.9	74.5	55.9	55.9	41.9
550	0.094x	-	94.0	70.5	68.3	51.2	51.2	38.4
500	0.103x	-	85.5	64.1	62.2	46.6	46.6	34.9
450	0.114x	-	77.0	57.7	56.0	42.0	42.0	31.5
400	0.129x	-	68.5	51.3	49.8	37.3	37.3	28.0
350	0.147x	1	60.0	45.0	43.6	32.7	32.7	24.5
300	0.171x	5	51.5	38.6	37.4	28.0	28.0	21.0
250	0.205x	5	43.0	32.2	31.2	23.4	23.4	17.5
200	0.256x	10	34.5	25.8	25.0	18.8	18.8	14.1
150	0.340x	15	25.9	19.4	18.8	14.1	14.1	10.6
100	0.507x	20	17.4	13.0	12.6	9.5	9.5	7.1

## HF75SA-1

Working Distance [mm]	Optical Magnification	Extension Tube [mm]	Field of View [mm]					
			2/3"		1/2"		1/3"	
			H	V	H	V	H	V
2000	0.038x	-	230.8	173.1	167.9	125.9	125.9	94.4
1950	0.039x	-	225.0	168.7	163.6	122.7	122.7	92.0
1900	0.040x	-	219.1	164.3	159.3	119.5	119.5	89.6
1850	0.041x	-	213.2	159.9	155.1	116.3	116.3	87.2
1800	0.042x	-	207.4	155.5	150.8	113.1	113.1	84.8
1750	0.044x	-	201.5	151.1	146.5	109.9	109.9	82.4
1700	0.045x	-	195.6	146.7	142.3	106.7	106.7	80.0
1650	0.046x	-	189.8	142.3	138.0	103.5	103.5	77.6
1600	0.048x	-	183.9	137.9	133.7	100.3	100.3	75.2
1550	0.049x	-	178.0	133.5	129.5	97.1	97.1	72.8
1500	0.051x	-	172.2	129.1	125.2	93.9	93.9	70.4
1450	0.053x	-	166.3	124.7	120.9	90.7	90.7	68.0
1400	0.055x	-	160.4	120.3	116.7	87.5	87.5	65.6
1350	0.057x	-	154.6	115.9	112.4	84.3	84.3	63.2
1300	0.059x	-	148.7	111.5	108.1	81.1	81.1	60.8
1250	0.062x	-	142.8	107.1	103.9	77.9	77.9	58.4
1200	0.064x	-	137.0	102.7	99.6	74.7	74.7	56.0
1150	0.067x	-	131.1	98.3	95.3	71.5	71.5	53.6
1100	0.070x	-	125.2	93.9				