

<u>Messrs.</u>	DATE	06, Apr, 2021
	Rev No.	1.7

This information is brought to you by:



APPROVAL SHEET

Description	Global Shutter Zoom Camera Series
Model Name	ATC-HZ5530W/T-LP

Receipt stamp

*Aegis Electronic Group
www.aegiselect.com*

Issued	Checked	Approved

Revision History

Date	Rev. No	Contents
2019.05	Rev.1.0	Release Document
2019.07	Rev.1.1	Modify Manual AGC and Menu Tree
2019.12	Rev.1.2	Dimension Changed Modify Power and Physical
2020.02	Rev.1.3	Modify Min. illumination value and Optical Zoom Position
2020.06	Rev.1.4	Insert ATC-HZ5530T-LP model
2020.08	Rev.1.5	Modify Focal Range SW101 Array Change
2021.08	Rev.1.6	Modify Supply Voltage
2022.04	Rev.1.7	Modify Minimum Supply Voltage Modify "STROBE_IN" to "STROBE_OUT"

TABLE OF CONTENTS

TABLE OF CONTENTS	-----	3
FEATURES	-----	4
PRECAUTION	-----	5
SPECIFICATIONSS	-----	6
DIMENSIONS	-----	9
INTERFACE	-----	11
OSD & MENU	-----	23
FUNCTIONS	-----	27
COMMAND LIST	-----	38

Aegis Electronic Group
www.aegiselect.com

FEATURES

This Product is a high performance CCTV camera with built-in 30x optical zoom and 12x digital zoom technologies. This product can be applied to various fields such as security camera for surveillance (CCTV camera), data viewer, Video presenter(VP) and speed dome camera and industrial applications.

- This camera uses a 1/1.8" 3.19M Global shutter or 1/2.9" 1.58M Global shutter CMOS Image Sensor that supports HD (high definition) to produce high-quality images.
- Using progressive scan, images with a wide dynamic range can be obtained with the newly developed image signal processor (Wide Dynamic Range function, WDR).
- The camera is equipped with a bright zoom lens with 30× optical zoom and F1.5 aperture (optical zoom + digital zoom = 360×)
- Low-noise images can be obtained even in low-light environments using the Noise Reduction function(3DNR/2DNR/2DNR+3DNR)
- Video signals can be output as digital only. Depending on register settings, you can select from a variety of digital output methods: 1080p/60,1080p/50,1080p/30, 1080p/25, 720p/60,720p/50,720p/30, 720p/25, 1080i/50, 1080i/60
- An infrared (IR) Cut-Filter can be disengaged from the image path for increased sensitivity in low light environments. The ICR will automatically engage depending on the ambient light, allowing the camera to be effective in day/night environment.
- A Privacy Zone Masking function (max. 8 blocks) is available.
- A Motion Detection function is available.
- A title composed of up to 21 lines can be set for displaying on the screen. 30 characters can be used on one line (VISCA).

- Support 256 internal zoom/focus presets.
- Digital Image Stabilizer function reduces image blurring caused by vibration.
- Output format
LVDS/CVBS/PARALLEL
- Asynchronous Reset Function

PRECAUTION

Operation is subject to the following conditions;

- This device may not cause harmful interference.
- This device must accept any interference received, including interference that may cause undesired operation.
- A regulated DC 12V 1A power supply is recommended for use with this camera for the best image and the most stable operation. An unregulated power supply can cause damage to the camera. When unregulated power supply is applied, product warranty will be out of subject.
- If it is used for CVBS application. It is recommended that the camera is used with a monitor that has a CCTV quality 75 Ohm video impedance level. If your monitor is switched to high impedance then please adjust accordingly.
- Do not attempt to disassemble the camera to gain access to the internal components. Refer servicing to your dealer.
- Never face the camera towards the sun or any bright or reflective light, which may cause smear on the image and possible damage to the CMOS.
- Do not remove the serial sticker for the warranty service.
- Do not drop the thing or give a strong impact to the product.
- Avoid the place where is so dusty, humid or soot-covered. It may cause electric shock or fire.
- Do not expose to an intense light source such as direct sunlight or spotlight. It may damage the CMOS.
- If the camera operates more than 24 hours, It is recommended that you execute the lens initial action or reset the camera.

Information may be changed without notice

This document provides technical information for the user. KT&C reserves the right to modify the information in this document as necessary. The customer should make sure that they have the most recent manual version.

SPECIFICATIONS

Format / Model	ATC-HZ5530W-LP	ATC-HZ5530T-LP
Video System		
Image Sensor	1/1.8" 3.19M Global shutter CMOS Image Sensor	1/2.9" 1.58M Global shutter CMOS Image Sensor
Effective Pixels	2064(H)x1544(V), Unit Cell Size(3.45μm X 3.45μm)	1456(H)x1088(V), Unit Cell Size(3.45μm X 3.45μm)
Output Format	LVDS/PARALLEL/CVBS : 1080p60/50/30/25, 720p60/50/30/25, 1080i60/50 Sensor Output : FULL/CROP Video Output : FULL/CROP	
Sensor Operating System	Sensor Master / Sensor Slave	
Sync System	Internal	
CVBS scale	16:9 / 4:3 (CVBS 720H)	
LVDS mode	Single / Dual	
Video Output	CVBS LVDS/PARALLEL	
Min. illumination	(Sens-up Off, AGC 242(45dB))	(Sens-up Off, AGC 159(45dB))
Day	0.1 Lux @ F1.5	0.1 Lux @ F1.6
Night (IR-cut filter on)	0.05. Lux @ F1.5	0.08 Lux @ F1.6
S/N ratio	More than 55 dB	More than 55 dB
Optical Lens		
Zoom Magnification	X30	X30
Practical f-value	6.0 to 180 mm	4.3 to 129.0 mm
Practical Horizontal-Angle	61.2°(W) ~ 2.32°(T)	58.9°(W) ~ 2.11°(T)
Practical Vertical Angle	36.1°(W) ~ 1.31°(T)	45.3°(W) ~ 1.61°(T)
F-value	F1.5(W) ~ F4.3(T)	F1.6(W) ~ F5.0(T)
Zoom		
Maximum Zoom Ratio	x1 ~ x360	x1 ~ x360
Optical Zoom Ratio	x1 ~ x30	x1 ~ x30
Digital Zoom Ratio	x1 ~ x12	x1 ~ x12
Digital Pan/Tilt	-	-
Speed (Focus Tracking On)	4.5 ~ 30 sec	3.8 ~ 40 sec
(Focus Tracking Off)	4.0 sec	2.8 sec
Focus		
6Control Mode	Auto / Manual / Interval / One Shot(=Zoom Trigger, One Push)/Preset	
Focal Range	Infinity~ 1.5m(T)~0.1m(W)	Infinity~ 1.0m(T)~0.01m(W)
IR correction	Standard/IR Light/user -20~+20	
Day & Night		
D&N mode	Auto / Day (Color) / Night (BW) / External-H / External-L	
Night Color	Off/On	
White Balance	Auto / ATW / Indoor / Outdoor / Push / Manual	
Exposure		
AE mode	Auto / Shutter Priority / Iris Priority/AGC Priority/Manual	
Brightness (Exp.Comp)	0~14	
AGC Limit	0(0dB)~255(48dB)	0(0dB)~255(d9X)
Manual Shutter	1/1,1/2,1/4,1/8,1/15(16),1/25(30)/1/50(60) ~ 1/10000	
Manual AGC	0dB ~ 48dB	0dB ~d9X (Analog gain : 0dB~48dB, Digital gain : d2X~d9X)
Manual Iris	F1.6 ~ F32, Close	
Sens-Up	Off ~ 32fields	
ETC	Spot AE, Slow AE response	

Format / Model	ATC-HZ5530W-LP	ATC-HZ5530T-LP
DSP functions		
Digital Slow Shutter	Max. 32 fields	
Image Freeze	Off / On	
Image Reverse (E-FLIP)	Off / Horizontal(mirror) / Vertical / H+V(180° flip)	
Privacy Masking	Spherical Privacy - 8-zone - Interlock / Non-Interlock Mask - 14 mask color selectable, semi-transparency - Pan(0°~360°), Tilt(+90°~-90°)	
Motion Detect	4-Zone - Alarm output : OSD / Serial Communication	
D-WDR	Off / Low/Middle/High	
WDR	Off/On, Adjustable(Level:0~29, Contrast:0~5,Bright:0~19)	
BLC	Off / On, Area selectable	
HLC	Off / On, Area selectable	
AGC	Max. 48dB	Max.48dB, d2X~d9X
Sharpness	Adjustable(0~15)	
3DNR	Off/Auto/Low/Middle/High	
2DNR	Off/Auto/Low/Middle/High	
Defog	Off / On / Auto	
Gamma	0.40/0.45/0.50/0.55/0.60/0.70/0.80/0.90/1.00	
Lens Shading	Off /ON	
Defect Detection	Support	
Digital Image Stabilizer	On /Off	
Picture Effect	OFF/NEGATIVE/GRAY MODE/REDDISH-1~4/BLUISH-1~4/GREENISH-1~4	
Picture In Picture	1/4,1/9,1/16,1/25	
Position Preset (zoom/focus)	Non-volatile 256 position(zoom/focus) presets.	
Memory Preset	16-presets & custom preset	
OSD	English	
Coaxial Communication	-	
Communication (UART)		
Camera ID	0~255	
Remote Control	RS-232 TTL +5.0V (+3.3V Compatible)	
Control Protocol	VISCA /Pelco-D/Pelco-P/HITACHI : automatically detection	
Communication Speed	2400/4800/9600(default)/19200/38400/57600/115200bps selectable	
Power		
Supply Voltage	DC 12V (+9.0V ~ +15V)	
Supplied Current (motor on)	420mA(620mA)	410mA(610mA)
Consumption (motor on)	5.0W(7.4W)	4.9W(7.3W)
Physical		
WxHxD[mm], Weight[g]		
- Standard	55x64x123mm, Approx. 372g	50x58.8x90.5mm, Approx. 244g
Temperature& Humidity		
Operating condition	Temperature (-10°C~50 °C / 14°F~122°F), Humidity (20% ~ 80%)	
Storage condition	Temperature (-20°C~60 °C / -4°F~140°F), Humidity (20% ~ 95%)	

INTERFACE SUMMARY

Interface & Video		ATC-HZ5530W-LP	ATC-HZ5530T-LP
Video Output	PARALLEL	⊙	⊙
	CVBS	○	○
	LVDS	⊙	⊙
Interface	32pin Micro Coaxial (USL00-30L-A, 0.4mm)	⊙	⊙
	36pinFFC (FH12-36S-0.5SH, 0.55mm)	○	○
	12pin External Sync& Trigger&Strobe (53261-1271, 1.25mm)	○	○
	4pin CVBS&ADKey&12V (53261-0471, 1.25mm)	○	○
	3pin External D&N (SM03B-SRSS-TB,1.0mm)	○	○
	3pin RS-232TTL (SM03B-SRSS-TB,0.1mm)	○	○

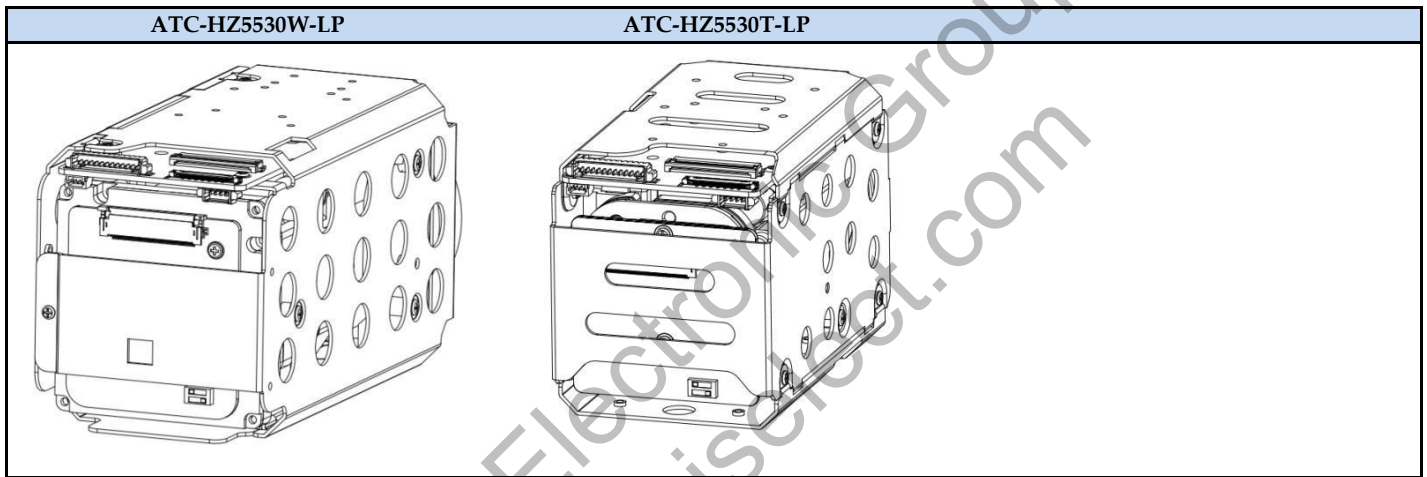

DIMENSION

DIMENSIONS

ATC-HZ5530W-LP

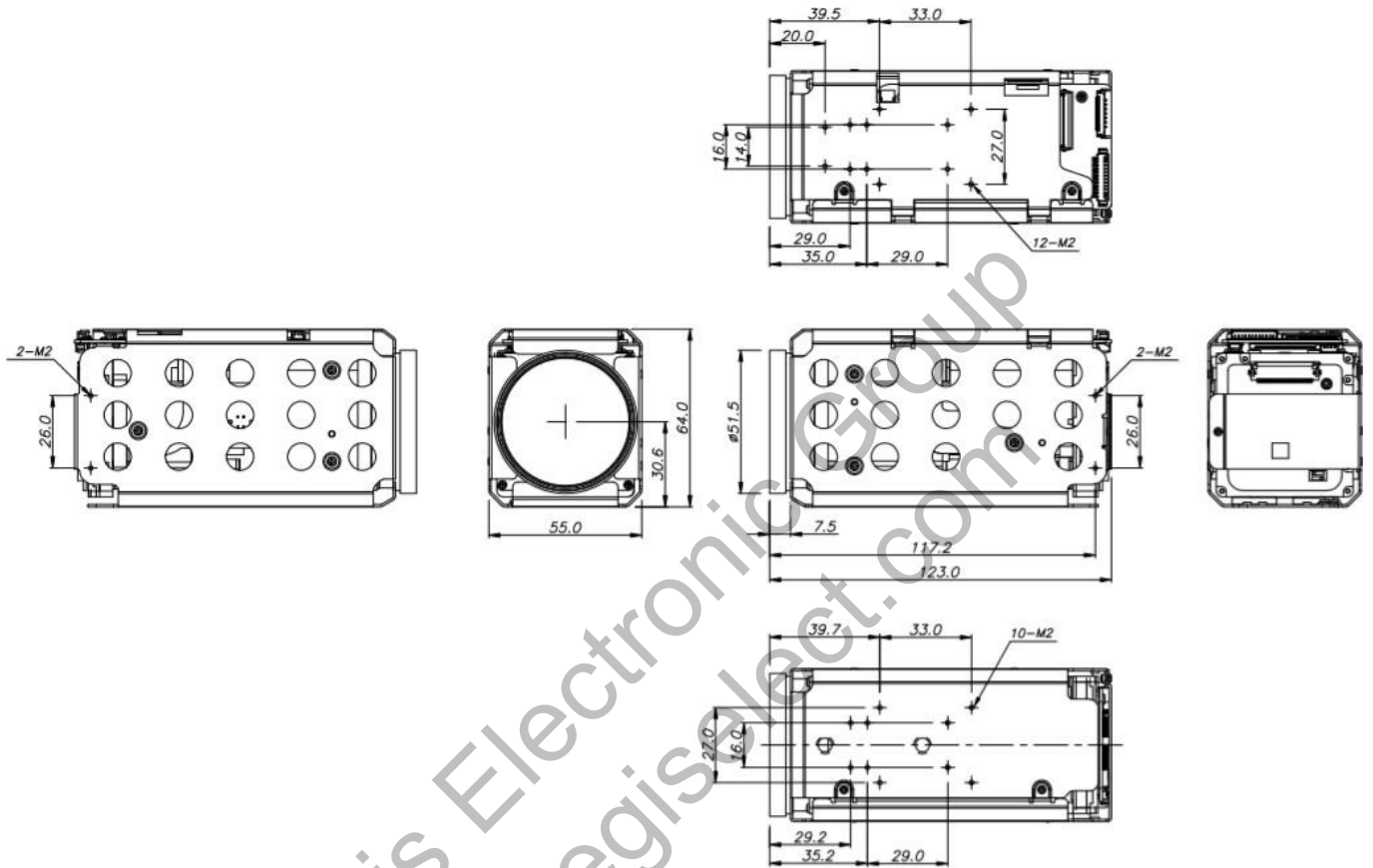

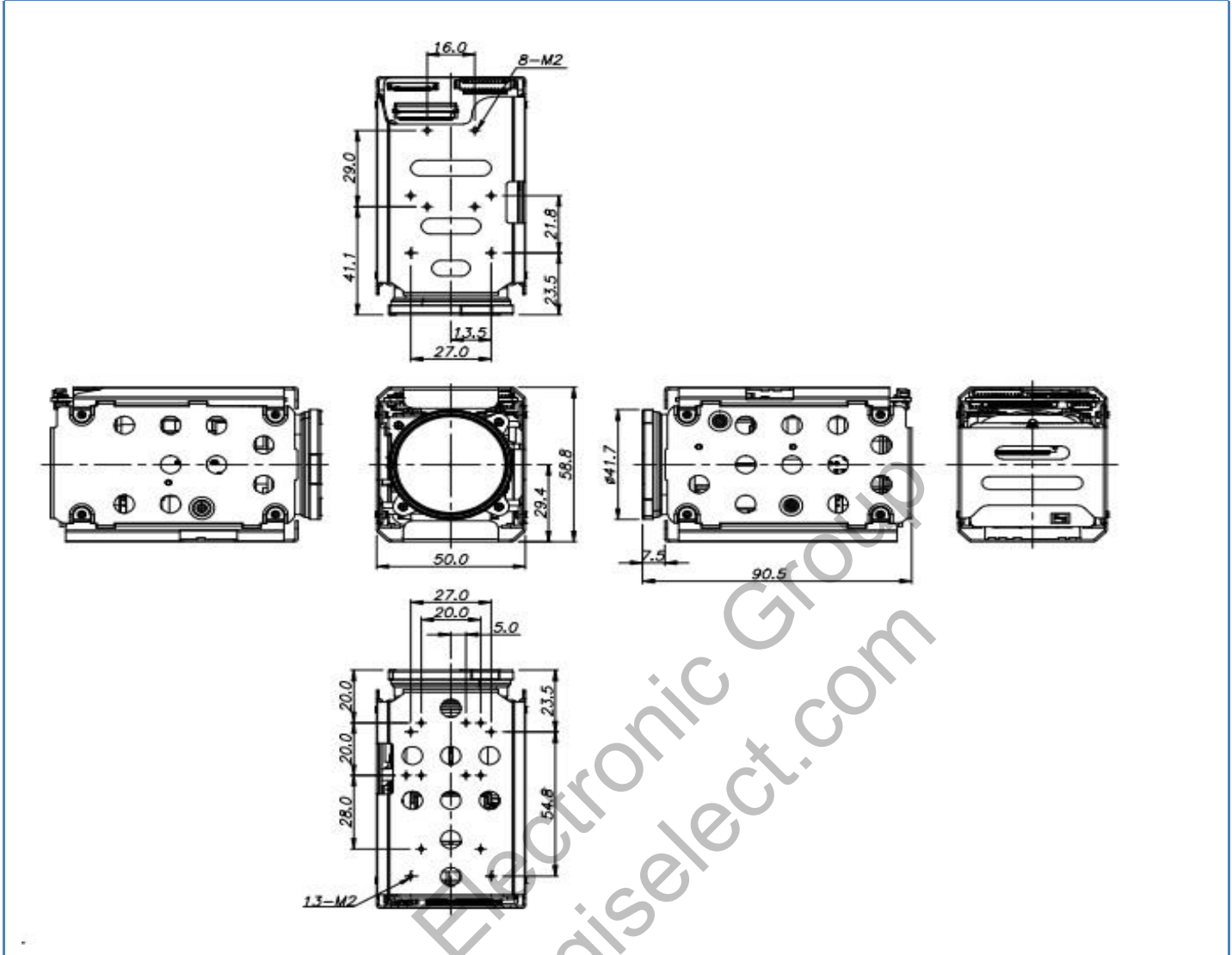

INTERFACE

INTERFACE

ATC-HZ5530W-LP

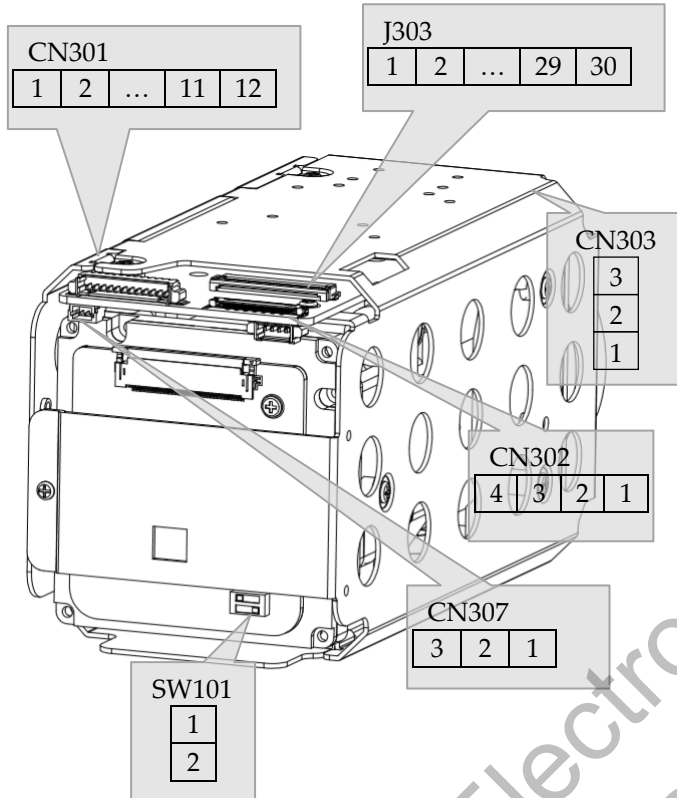

CN301/53261-1271

NO	Name	Description
1	VS_OUT	EXT_VS Out
2	HS_OUT	EXT_HS Out
3	CLK_OUT	EXT_CLK Out
4	GND	
5	VS_IN	EXT_VS In
6	HS_IN	EXT_HS In
7	CLK_IN	EXT_CLK In
8	GND	
9	TRIG_COM	
10	Trigger_IN	EXT_TRIG In
11	STROBE_COM	
12	STROBE_OUT	STROBE

(*)CLK_OUT line should be shielded to reduce a noise.

CN302(CVBS)/53261-0471

NO	Name	Description
1	+12V_IN	+12V In
2	GND	
3	CVBS_OUT	CVBS Out
4	AD_KEY	AD_KEY

CN303/SM03B-SRSS-TB

NO	Name	Description
1	EXT_DN	External D&N Input
2	GND	
3	+3.3V	+3.3V Out (For Sensor)

CN307/SM03B-SRSS-TB

NO	Name	Description
1	GND	
2	UART_RX	UART_RX
3	UART_TX	UART_TX

J303 (LVDS)/USL00-30L-C

NO	Name	Description
1	TX_OUT3+	
2	TX_OUT3-	
3	TX_CLKOUT+	LVDS_CLK
4	TX_CLKOUT-	LVDS_CLK
5	TX_OUT2+	
6	TX_OUT2-	
7	TX_OUT1+	
8	TX_OUT1-	
9	TX_OUT0+	
10	TX_OUT0-	
11	GND	
12	TXD	5.0V (compatible 3.3V)
13	RXD	5.0V (compatible 3.3V)
14	+12V DC	
15	+12V DC	
16	+12V DC	
17	+12V DC	
18	+12V DC	
19	GND	
20	GND	
21	TX_OUT7+	Single out mode : open
22	TX_OUT7-	Single out mode : open
23	TX_OUT6+	Single out mode : open
24	TX_OUT6-	Single out mode : open
25	CVBS	CVBS Out
26	RESET_IN	Reset:Low(GND),Normal(1.8V)
27	TX_OUT5+	Single out mode : open
28	TX_OUT5-	Single out mode : open
29	TX_OUT4+	Single out mode : open
30	TX_OUT4-	Single out mode : open

SW101

Sensor Mode	Switch 1	Switch 2
Sensor Master	ON	OFF
Sensor Slave	OFF	ON

J304

1	2	3	...	35	36
---	---	---	-----	----	----

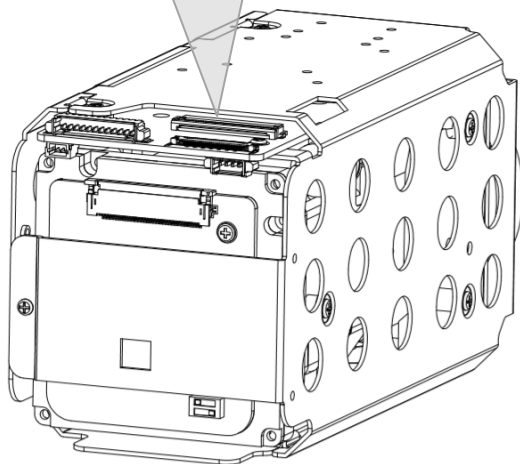

J304 (PARALLEL)/ FH12-36S-05SH

NO	Name	Description
1	GND	
2	Y_OUT[0]	
3	Y_OUT[1]	
4	Y_OUT[2]	
5	Y_OUT[3]	
6	GND	
7	Y_OUT[4]	
8	Y_OUT[5]	
9	Y_OUT[6]	
10	Y_OUT[7]	
11	GND	
12	C_OUT[0]	
13	C_OUT[1]	
14	C_OUT[2]	
15	C_OUT[3]	
16	GND	
17	C_OUT[4]	
18	C_OUT[5]	
19	C_OUT[6]	
20	C_OUT[7]	
21	GND	
22	VSYNC	VSYNC Out
23	HSYNC	HSYNC Out
24	GND	
25	DIGITAL_CLK	VCLK Out
26	GND	
27	GND	
28	GND	
29	GND	
30	GND	
31	+12V_IN	
32	+12V_IN	
33	+12V_IN	
34	GND	
35	TXD	5.0V (compatible 3.3V)
36	RXD	5.0V (compatible 3.3V)

Aegis Electronic Group
www.aegis-elect.com

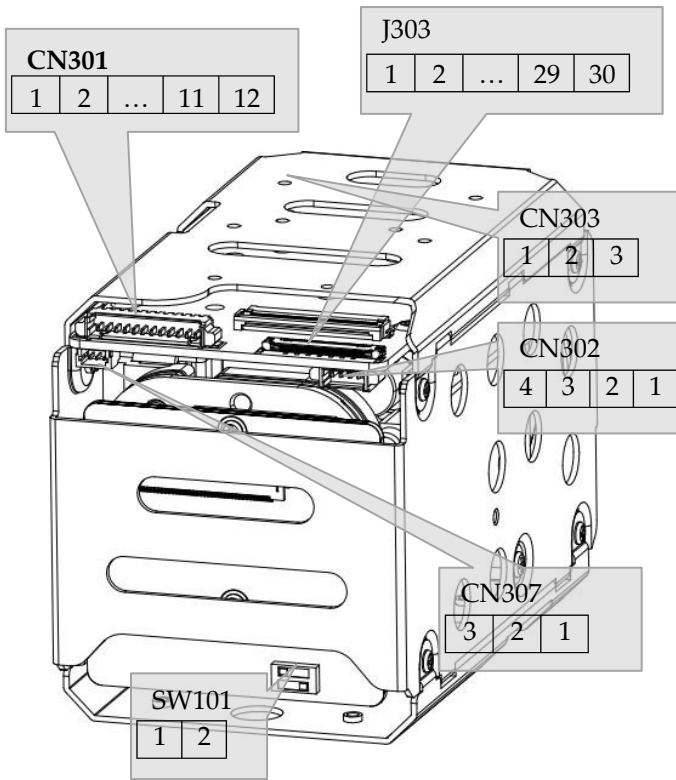

CN301/53261-1271

NO	Name	Description
1	VS_OUT	EXT_VS Out
2	HS_OUT	EXT_HS Out
3	CLK_OUT	EXT_CLK Out
4	GND	
5	VS_IN	EXT_VS In
6	HS_IN	EXT_HS In
7	CLK_IN	EXT_CLK In
8	GND	
9	TRIG_COM	
10	Trigger_IN	EXT_TRIG In
11	STROBE_COM	
12	STROBE_OUT	STROBE

(*)CLK_OUT line should be shielded to reduce a noise.

CN302(CVBS)/53261-0471

NO	Name	Description
1	+12V_IN	+12V In
2	GND	
3	CVBS_OUT	CVBS Out
4	AD_KEY	AD_KEY

CN303/SM03B-SRSS-TB

NO	Name	Description
1	EXT_DN	External D&N Input
2	GND	
3	+3.3V	+3.3V Out (For Sensor)

CN307/SM03B-SRSS-TB

NO	Name	Description
1	GND	
2	UART_RX	UART_RX
3	UART_TX	UART_TX

J303 (LVDS)/USL00-30L-C

NO	Name	Description
1	TX_OUT3+	
2	TX_OUT3-	
3	TX_CLKOUT+	LVDS_CLK
4	TX_CLKOUT-	LVDS_CLK
5	TX_OUT2+	
6	TX_OUT2-	
7	TX_OUT1+	
8	TX_OUT1-	
9	TX_OUT0+	
10	TX_OUT0-	
11	GND	
12	TXD	5.0V (compatible 3.3V)
13	RXD	5.0V (compatible 3.3V)
14	+12V DC	
15	+12V DC	
16	+12V DC	
17	+12V DC	
18	+12V DC	
19	GND	
20	GND	
21	TX_OUT7+	Single out mode : open
22	TX_OUT7-	Single out mode : open
23	TX_OUT6+	Single out mode : open
24	TX_OUT6-	Single out mode : open
25	CVBS	CVBS Out
26	RESET_IN	Reset:Low(GND),Normal(1.8V)
27	TX_OUT5+	Single out mode : open
28	TX_OUT5-	Single out mode : open
29	TX_OUT4+	Single out mode : open
30	TX_OUT4-	Single out mode : open

SW101

Sensor Mode	Switch 1	Switch 2
Sensor Master	ON	OFF
Sensor Slave	OFF	ON

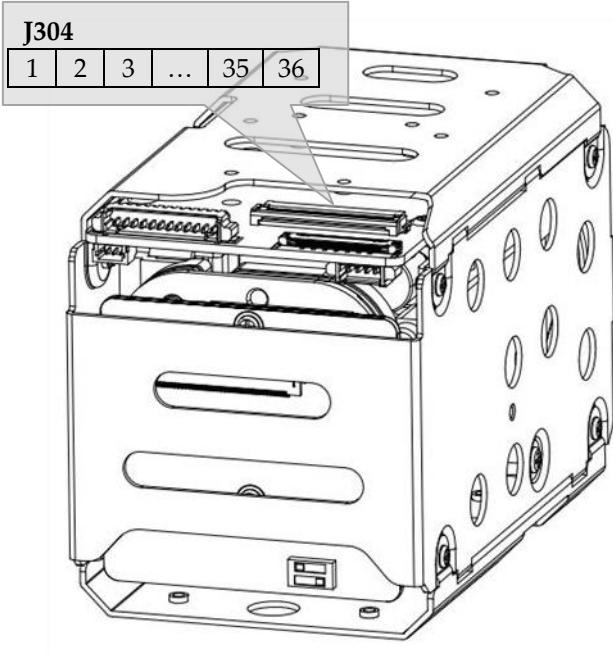

J304 (PARALLEL)/ FH12-36S-0.5SH

NO	Name	Description
1	GND	
2	Y_OUT[0]	
3	Y_OUT[1]	
4	Y_OUT[2]	
5	Y_OUT[3]	
6	GND	
7	Y_OUT[4]	
8	Y_OUT[5]	
9	Y_OUT[6]	
10	Y_OUT[7]	
11	GND	
12	C_OUT[0]	
13	C_OUT[1]	
14	C_OUT[2]	
15	C_OUT[3]	
16	GND	
17	C_OUT[4]	
18	C_OUT[5]	
19	C_OUT[6]	
20	C_OUT[7]	
21	GND	
22	VSYNC	VSYNC Out
23	HSYNC	HSYNC Out
24	GND	
25	DIGITAL_CLK	VCLK Out
26	GND	
27	GND	
28	GND	
29	GND	
30	GND	
31	+12V_IN	
32	+12V_IN	
33	+12V_IN	
34	GND	
35	TXD	5.0V (compatible 3.3V)
36	RXD	5.0V (compatible 3.3V)

Aegis Electronic Group
www.aegis-elect.com

LVDS interface (LVDS model only)

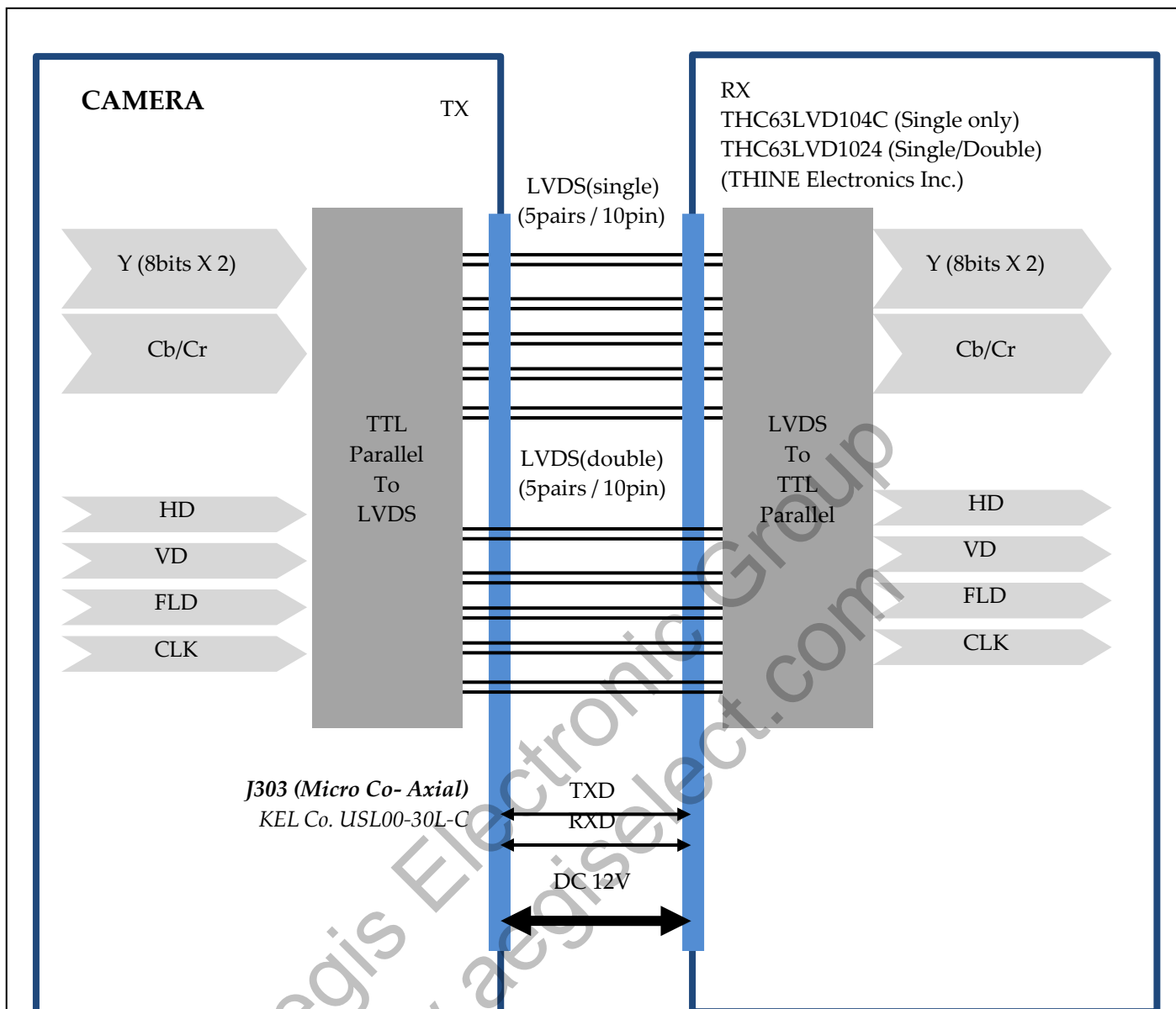

HD Digital Video Sync Signal
74.125MHz

Recommended LVDS receiver IC
(1) Single Only : THC63LVD104C
(2) Single or Double : THC63LVD1024

Select LVDS output mode

(1) MENU
SPECIAL -> SYSTEM -> LVDS MODE : SINGLE/DUAL

(2) VISCA protocol
8x 01 04 24 74 0p 0q FF : pq=00 (single) / pq=01 (double)

(caution) If the frame rate is 25 fps / 30 fps, it works as SINGLE even if LVDS MODE is set to DUAL.

However, if the frame rate is 50 fps / 60 fps, LVDS MODE must be set to DUAL to operate as DUAL.

Single Mode : THC63LVD827 (THINE Electronics Inc.)

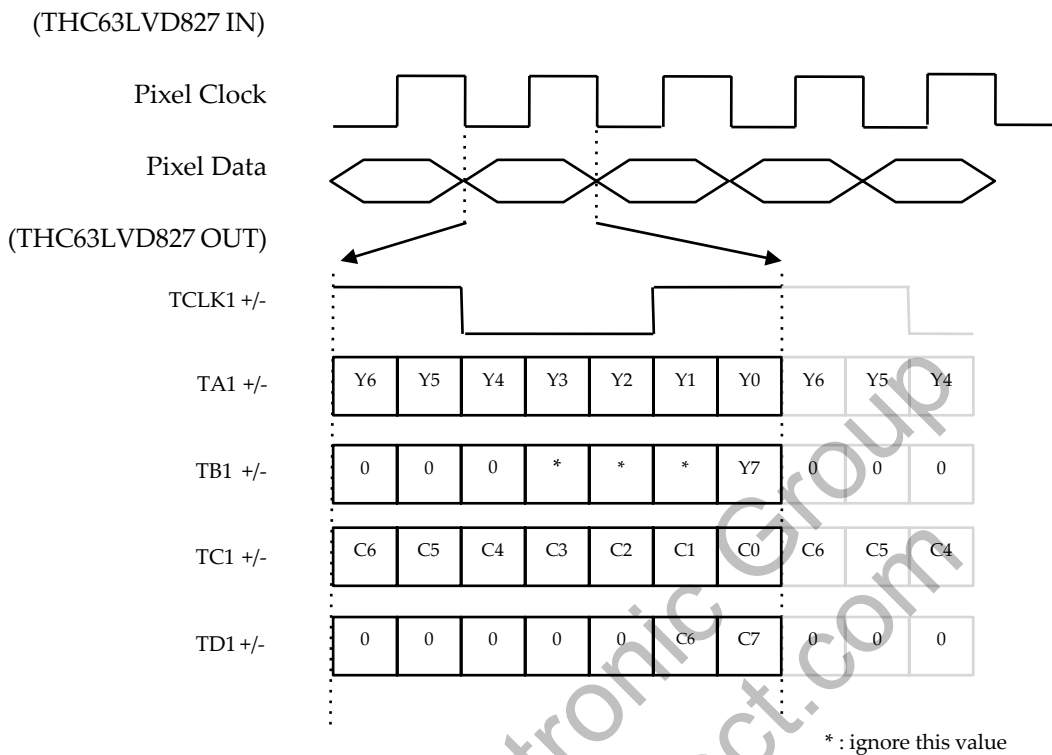

Output Format	Pixel Clock [MHz]	TCLK+ [MHz]
1080p60	148.5	148.5
1080p50	148.5	148.5
1080i60	74.25	74.25
1080i50	74.25	74.25
1080p30	74.25	74.25
1080p25	74.25	74.25
720p60	74.25	74.25
720p50	74.25	74.25
720p30	74.25	74.25
720p25	74.25	74.25

Double Mode : THC63LVD827 (THINE Electronics Inc.)

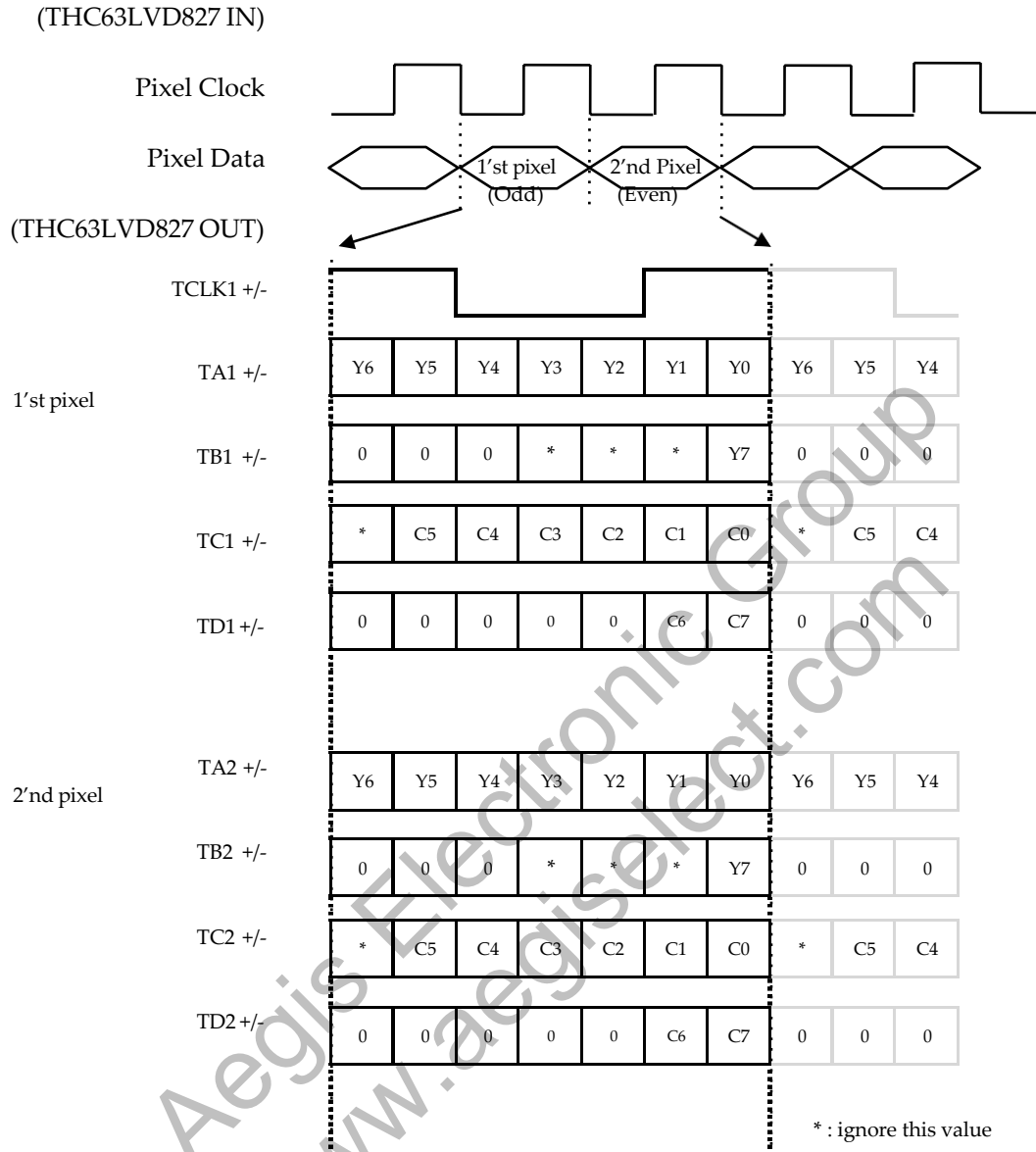

Output Format	Pixel Clock [MHz]	TCLK+ [MHz]
1080p60	148.5	74.25
1080p50	148.5	74.25
1080i60	74.25	37.125
1080i50	74.25	37.125
1080p30	74.25	37.125
1080p25	74.25	37.125
720p60	74.25	37.125
720p50	74.25	37.125
720p30	74.25	37.125
720p25	74.25	37.125

LVDS Receive Circuit Example (LVDS model only)

LVDS Single Output receiver circuit example / Receiver IC : THC63LVD104C

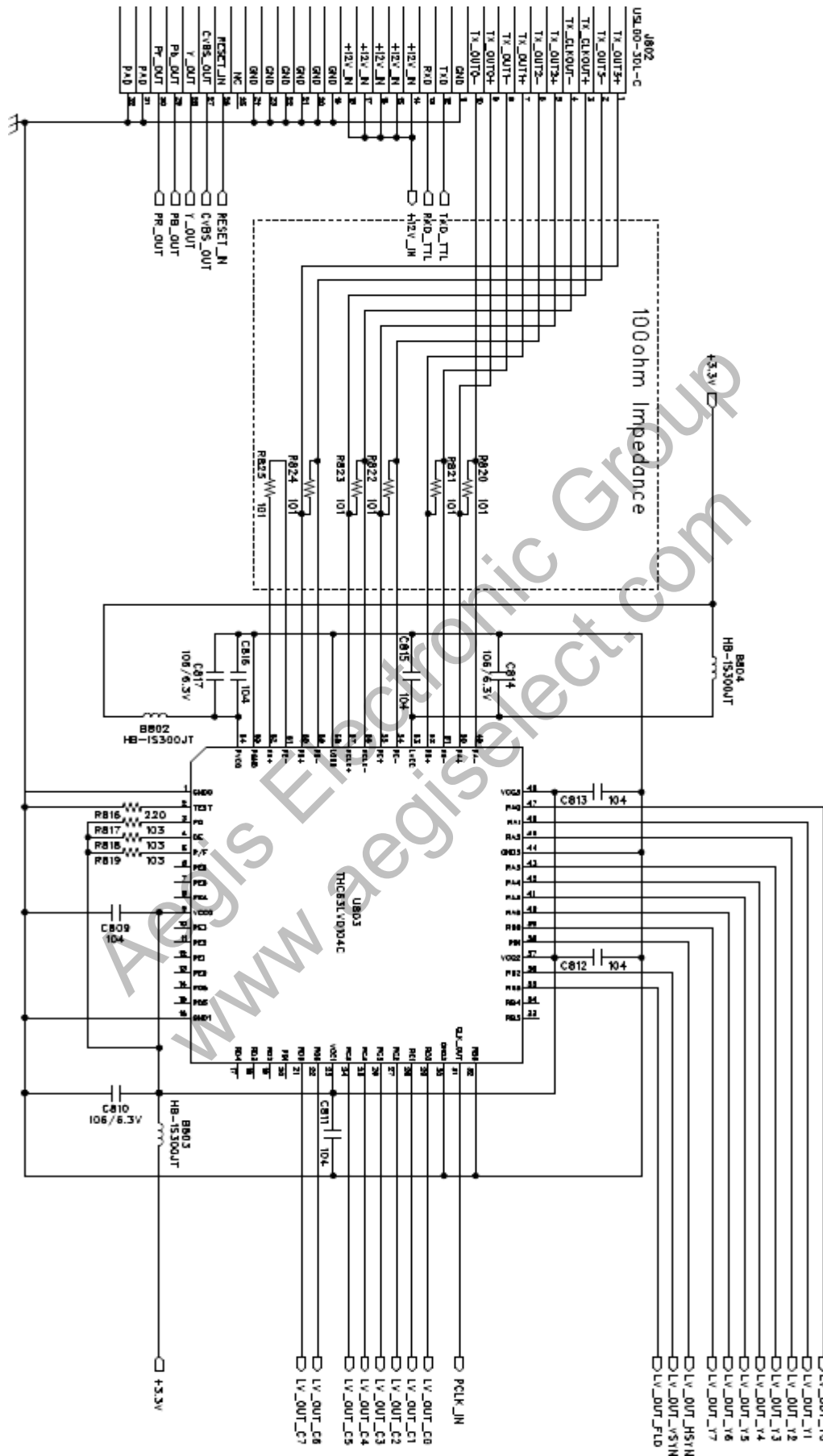

LVDS Single Output receiver circuit example / Receiver IC Pin Assign : THC63LVD104C

Pin No.	Description	Signal
1	GND0	
2	TEST	
3	PD	
4	OE	
5	R/F	
6	RE6	
7	RE5	
8	RE4	
9	VCC0	
10	RE3	
11	RE2	
12	RE1	
13	RE0	
14	RD6	
15	RD5	
16	GND1	
17	RD4	
18	RD3	
19	RD2	
20	RD1	
21	RD0	C7
22	RC6	C6
23	VCC1	
24	RC5	C5
25	RC4	C4
26	RC3	C3
27	RC2	C2
28	RC1	C1
29	RC0	C0
30	GND2	
31	CLK_OUT	PCLK
32	RB6	

Pin No.	Description	Signal
33	RB5	
34	RB4	
35	RB3	FLD
36	RB2	VSYNC
37	VCC2	
38	RB1	HSYNC
39	RB0	Y7
40	RA6	Y6
41	RA5	Y5
42	RA4	Y4
43	RA3	Y3
44	GND3	
45	RA2	Y2
46	RA1	Y1
47	RA0	Y0
48	VCC3	
49	RA-	TXOUT0-
50	RA+	TXOUT0+
51	RB-	TXOUT1-
52	RB+	TXOUT1+
53	LVCC	
54	RC-	TXOUT2-
55	RC+	TXOUT2+
56	RCLK-	TXCLKOUT-
57	RCLK+	TXCLKOUT+
58	LGND	
59	RD-	TXOUT3-
60	RD+	TXOUT3+
61	RE-	
62	RE+	
63	PGND	
64	PVCC	

LVDS Single Output receiver circuit example / Receiver IC : THC63LVD1024

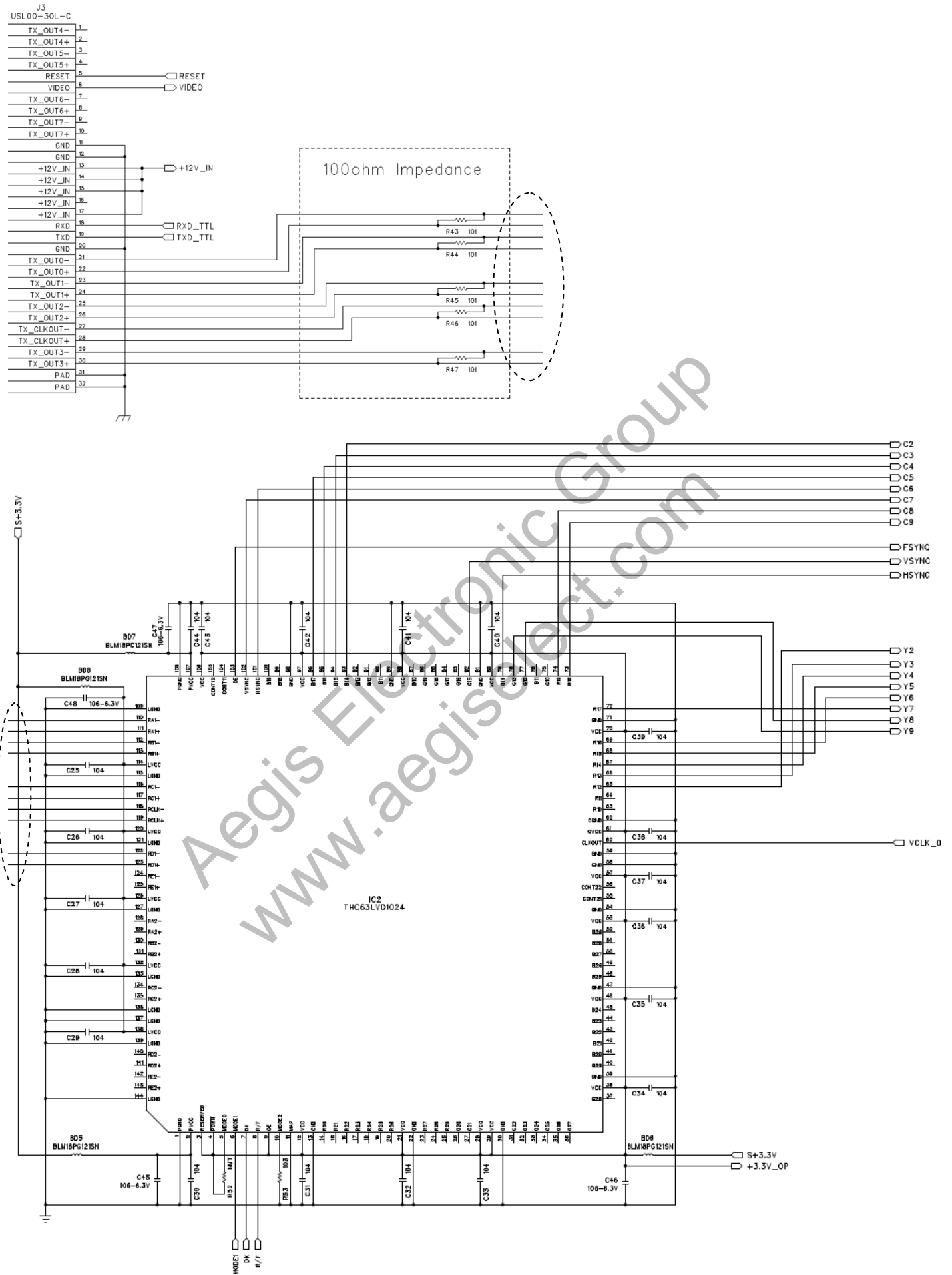

LVDS Double Output receiver circuit example / Receiver IC : THC63LVD1024



LVDS Single/Double Output receiver circuit example / Receiver IC Pin Assign : THC63LVD1024

Pin No.	Description	Signal
1	PGND	
2	PVCC	
3	RESERVED	
4	PDWN	
5	MODE0	
6	MODE1	MODE1
7	DK	DK
8	R/F	R/F
9	OE	
10	MODE2	
11	MAP	
12	VCC	
13	GND	
14	R20	
15	R21	
16	R22	
17	R23	
18	R24	
19	R25	
20	R26	
21	VCC	
22	GND	
23	R27	
24	R28	
25	R29	
26	G20	
27	G21	
28	VCC	
29	VCC	
30	GND	
31	G22	
32	G23	
33	G24	
34	G25	
35	G26	
36	G27	
37	G28	
38	VCC	
39	GND	
40	G29	
41	B20	
42	B21	
43	B22	
44	B23	
45	B24	
46	VCC	
47	GND	
48	B25	
49	B26	
50	B27	

Pin No.	Description	Signal
51	B28	
52	B29	
53	VCC	
54	GND	
55	CONT21	
56	CONT22	
57	VCC	
58	GND	
59	GND	
60	CLKOUT	VCLK
61	CVCC	
62	CGND	
63	R10	
64	R11	
65	R12	Y2
66	R13	Y3
67	R14	Y4
68	R15	Y5
69	R16	Y6
70	VCC	
71	GND	
72	R17	Y7
73	R18	C9
74	R19	C8
75	G10	
76	G11	
77	G12	Y8
78	G13	Y9
79	G14	HSYNC
80	VCC	
81	GND	
82	G15	VSYNC
83	G16	
84	G17	
85	G18	
86	G19	
87	B10	
88	VCC	
89	GND	
90	B11	
91	B12	
92	B13	
93	B14	C2
94	B15	C3
95	B16	C4
96	B17	C5
97	VCC	
98	GND	
99	B18	
100	B19	

Pin No.	Description	Signal
101	HSYNC	C6
102	VSYNC	C7
103	DE	FSYNC
104	CONT11	
105	CONT12	
106	VCC	
107	PVCC	
108	PGND	
109	LGND	
110	RA1-	TXOUT0-
111	RA1+	TXOUT0+
112	RB1-	TXOUT1-
113	RB1+	TXOUT1+
114	LVCC	
115	LGND	
116	RC1-	TXOUT2-
117	RC1+	TXOUT2+
118	RCLK-	TXCLKOUT-
119	RCLK+	TXCLKOUT+
120	LVCC	
121	LGND	
122	RD1-	TXOUT3-
123	RD1+	TXOUT3+
124	RE1-	
125	RE1+	
126	LVCC	
127	LGND	
128	RA2-	TXOUT4-
129	RA2+	TXOUT4+
130	RB2-	TXOUT5-
131	RB2+	TXOUT5+
132	LVCC	
133	LGND	
134	RC2-	TXOUT6-
135	RC2+	TXOUT6+
136	LGND	
137	LGND	
138	LVCC	
139	LGND	
140	RD2-	TXOUT7-
141	RD2+	TXOUT7+
142	RE2-	
143	RE2+	
144	LGND	

OSD & MENU

1'ST ITEM	2'ND ITEM	3'RD ITEM or DATA	4'TH ITEM or DATA	5'TH ITEM or DATA	
FOCUS	AF MODE	AUTO/INTERVAL/ONE PUSH/MANUAL/PRESET			
	DZOOM	OFF/ON			
	ZOOM START	1~30			
	ZOOM STOP	1~360			
	ZOOM SPEED	0~7			
	FOCUS LIMIT	10CM/50CM/1M/1.5M/2M/3M/5M/10M/30M/60M/100M/200M/500M/INF			
	AF INTERVAL	1~255			
	IR CORRECT	STANDARD/IR LIGHT/USER -20~+20			
	PRESET MARGIN	0~255			
	POWER ON HOME	OFF/ON			
	AF SPEED	0~7			
	INITIAL				
	RETURN				
EXPOSURE	AE MODE	AUTO/SHUT.PRI/IRIS.PRI/AGC.PRI/MANUAL			
	SHUTTER	1/1~1/10000			
	IRIS	CLOSE~F1.6			
	AGC	HZ5530W-LP : 0dB ~ 48Db HZ5530T-LP : 0dB ~d9X (Analog gain : 0dB~48dB, Digital gain : d2X~d9X)			
	AGC MAX	0~255			
	SENS-UP MAX	OFF/X2/X4/X8/X16/X32			
	FLICKERLESS	OFF/AUTO			
	BRIGHTNESS	0~14			
	AE RESPONSE	0~48			
	INITIAL				
	RETURN				
WHITE BALANCE	MODE	AUTO/INDOOR/OUTDOOR/ONE PUSH/ATW/MANUAL			
	PUSH	PRESSOK/WAIT			
	BLUE	0~255			
	RED	0~255			
	SPEED	0~7			
	OFFSET-BLUE	0~100			
	OFFSET-RED	0~100			
	SATURATION	0~20			
	HUE	0~20			
	INITIAL				
	RETURN				
WDR/BLC	BACKLIGHT	OFF/BLC/HLC			
	WDR	OFF/ON			
	BLC SET	POSITION-X		0~46	
		POSITION-Y		0~32	
		SIZE-X		0~46	
		SIZE-Y		0~32	
		RETURN			
	HLC SET	POSITION-X		0~46	
		POSITION-Y		0~32	
		SIZE-X		0~46	
		SIZE-Y		0~32	
		LEVEL		0~20	
		BLACK MASK		OFF/ON	
		RETURN			
	WDR SET	LEVEL		0~29	
CONTRAST			0~5		

		BREIGHT	0~19	
		AGC MAX	1~50	
		RETURN		
	INITIAL			
	RETURN			
DAY&NIGHT	MODE	AUTO/DAY(COLOR)/NIGHT(BW)/EXT-H/EXT-L		
	DELAY[SEC]	1~60		
	D->N LEVEL	2~255		
	N->D LEVEL	1~255		
	NIGHT COLOR	OFF/ON		
	COLOR BURST	OFF/ON		
	INITIAL			
	RETURN			
IMAGE	SHARPNESS	0~15		
	CONTRAST	0~20		
	GAMMA	0.4/0.45/0.5/0.55/0.6/0.7/0.8/0.9/1.0		
	SHADING	OFF/ON		
	FREEZE	OFF/ON		
	EFFECT	OFF/NEGATIVE/GRAY MODE/REDDISH-1~4/BLUISH-1~4/GREENISH-1~4		
	ROTATE	MIRROR	OFF/H-FLIP/V-FLIP/HV-FLIP	
		CORRIDOR VIEW	OFF/FULL/CROP	
		RETURN		
	DNR	MODE	OFF/2D/3D/2D+3D	
		LEVEL	AUTO/LOW/MIDDLE/HIGH	
		APERTURE	0~4	
		RETURN		
	DEFOG	MODE	OFF/ON/AUTO	
		STRENGTH	0~16	
		THRESHOLD	0~3	
		AUTO LEVEL	LOW/MIDDLE/HIGH	
		RETURN		
	DWDR	MODE	OFF/ON/AUTO	
		STRENGTH	0~16	
		AUTO LEVEL	LOW/MIDDLE/HIGH	
		RETURN		
	DIS	OFF/ON		
INITIAL				
RETURN				
SPECIAL	TITLE	EDIT PANEL		
		↓		
		<pre> - - - - - A B C D E F G H I J K L M N O P Q R S T U V W X Y Z ! ? 0 1 2 3 4 5 6 7 8 9 ~ () ^ SP> <BK</pre>		
		DISPLAY	OFF/ON	
		POSITION	[POSITION EDIT]	
		TEXT COLOR	WHITE/BLACK/BLUE/GRAY/YELLOW	
	INITIAL			
	RETURN			
	DISPLAY	ZOOM RATIO	OFF/ON	
		ZOOM RATIO POS	[POSITION EDIT]	
		CAMERA ID	OFF/ON	
		CAMERA ID POS	[POSITION EDIT]	
		INITIAL		
RETURN				
PRIVACY	MODE	OFF/ON		
	MASK NO	1~8		

		DISPLAY	OFF/ON	
		PAN/TILT LOCK	OFF/ON	
		MASK COLOR	BLACK/GRAY1~6/WHITE/GREEN/BLUE/RED/CYAN/MAGENTA/YELLOW/MOSAIC	
		POSITION-X	0~160	
		POSITION-Y	0~90	
		SIZE-X	1~80	
		SIZE-Y	1~45	
		MASK RESET	PUSH	
		INITIAL		
		RETURN		
	MOTION	MODE	OFF/ON	
		AREA NO	1~4	
		AREA ENABLE	OFF/ON	
		AREA SET	POSITION-X	0~119
			POSITION-Y	0~69
			SIZE-X	0~120
			SIZE-Y	0~70
		RETURN		
		ALARM WINDOW	OFF/ON	
		ALARM TEXT	OFF/ON	
		ALARM BLOCK	OFF/ON	
		SENSITIVITY	0~40	
		INITIAL		
		RETURN		
	PIP	MODE	OFF/ON	
		SIZE	1/4,1/9,1/16,1/25	
		POSITION-X	0~10	
		POSITION-Y	0~10	
		INITIAL		
		RETURN		
	ETC	BINNING	OFF/ON	
		DEFECT PIXEL	DEFECT PIXEL	OFF/ON/STATIC ON(FIXED)
			STATIC PROCESS	PRESS OK
		RETURN		
		RETURN		
	INITIAL			
	RETURN			
SYSTEM (*It is not initialized by "Factory default")	OUTPUT FORMAT	1080p25/30/50/60, 1080i50/60, 720p25/30/50/60		
	APPLY	YES / NO		
	SERIAL	CAM ID	0~255	
		BAUDRATE	2400/4800/9600/19200/38400/57600/115200	
		PARITY	NONE/EVEN/ODD	
		PROTOCOL	AUTO/VISCA/AFP	
		APPLY	YES / NO	
		RETURN		
	COLOR ADJUST	LINE-RED	0~10	
		LINE-GREEN	0~10	
		LINE-BLUE	0~10	
		COLOR AREA	RED/BLUE/GREEN/CYAN/MAGENTA/YELLOW	
		COLOR HUE	0~180	
		COLOR GAIN	0~64	
		SAVE	PRESS OK	
		RETURN		
	TRIGGER&SCAN (*HZ5530W model)	TRIGGER MODE	---	
SENSOR SCAN		FULL/CROP		
OUTPUT SCAN		---		

		APPLY	YES/NO	
		STROBE SIGNAL	OUTSET CENTER	-127~128
			STROBE WIDTH	-127~128
			STROBE REPEAT	---
			REPEAT COUNT	---
			STROBE POLARI	OFF/ON
			FREE.STROBE	OFF/ON
			RESET	
			RETURN	
		EXT.TRIG SET	---	
		RETURN		
	TRIGGER&SCAN (*)HZ5530T model	TRIGGER MODE	OFF/NORMAL/VD SYNC/ASYN	
		SENSOR SCAN	FULL/CROP	
		OUTPUT SCAN	FULL/CROP	
		APPLY	YES/NO	
		STROBE SIGNAL	CENTER SHIFT	-127~128
			WIDTH OFFSET	-127~128
			STROBE REPEAT	OFF/ON/ENDLESS
			REPEAT COUNT	2~255
			STROBE POLARI	OFF/ON
			FREE.STROBE	OFF/ON
			RESET	
			RETURN	
		EXT.TRIG SET	TRIG EDGE	FALLING/RISING
			TRIG POLARITY	OFF/ON
			RETUTN	
		RETURN		
	MENU SET	LANGUAGE	---	
		MENU POSITION	DEFAULT/TOP-LEFT,RIGHT/BOT-LEFT,RIGHT	
		MENU COLOR	TEXT COLOR	WHITE/YELLOW/G
			TEXT(H) COLOR	RAY/BLUE/BLACK/
			B/G COLOR	BLACK OP/WHITE
			B/G(H) COLOR	OP/NO COLOR
			RETURN	
		OSD TYPE	NORMAL/CVBS	
		RETURN		
	LVDS SET (*)only can be used on 1080p50 or 1080p60.	LVDS MODE	SINGLE/DUAL	
		APPLY	YES/NO	
		RETURN		
	PICTURE STYLE	PICTURE STYLE	OFF/STANDARD/VIVID/CLEAR/ VIVID CLR/NEUTRAL	
		PIC CONTRAST	0~6	
		PIC SATURATION	0~6	
		PIC EDGE	0~6	
		RESET		
		RETURN		
	CVBS ASPECT	16:9, 4:3		
	RETURN			
FACTORY RESET	YES / NO			
EXIT				

FUNCTIONS

(!!!) Memory Control Function Priority

Function	Priority	Etc
D-ZOOM	1	Digital Zoom Function
WDR	2-2	Wide Dynamic Range
DIS	2-2	Digital Image Stabilizer
PIP	2-3	Picture In Picture
COR.VIEW	3	Corridor View. It is not H-FILIP / V-FLIP / HV-FLIP.

* Digital Zoom : Highest Priority

When D-ZOOM is ON, DIS and COR.VIEW are unconditionally turned OFF.

D-ZOOM	WDR	DIS	PIP	COR.VIEW
OFF	○	○	○	○
ON	○	X	○	X

* WDR / DIS / PIP will activate the later ON function. If multiple functions are ON at the same time, it will be turned on in WDR / DIS / PIP order. However, DIS is unconditionally turned off when D-ZOOM is turned on.

D-ZOOM	WDR	DIS	PIP	COR.VIEW
---	OFF	ON/OFF	ON/OFF	ON/OFF
---	ON	OFF	OFF	OFF

D-ZOOM	DIS	WDR	PIP	COR.VIEW
---	OFF	ON/OFF	ON/OFF	ON/OFF
---	ON	OFF	OFF	OFF

D-ZOOM	PIP	WDR	DIS	COR.VIEW
---	OFF	ON/OFF	ON/OFF	ON/OFF
---	ON	OFF	OFF	OFF

* Corridor VIEW can be controlled only when both D-ZOOM / WDR / DIS / PIP are OFF.

* Corridor VIEW does not work on 1080p50 / 60.

(!!!) Sensor Master / Slave

You can change the sensor mode using a switch.



< Slave Mode >



< Master Mode >

Sensor Mode	Switch 1	Switch 2
Sensor Master	ON	OFF
Sensor Slave	OFF	ON

Auto Focus Near Limit

You can set the minimum focus distance from 1cm(or 10cm) to infinite. It is available only at high magnification zoom position.

This is called by FOCUS LIMIT or NEAR LIMIT or M.O.D (Minimum object distance). This is mostly used to avoid focusing on objects of close range.

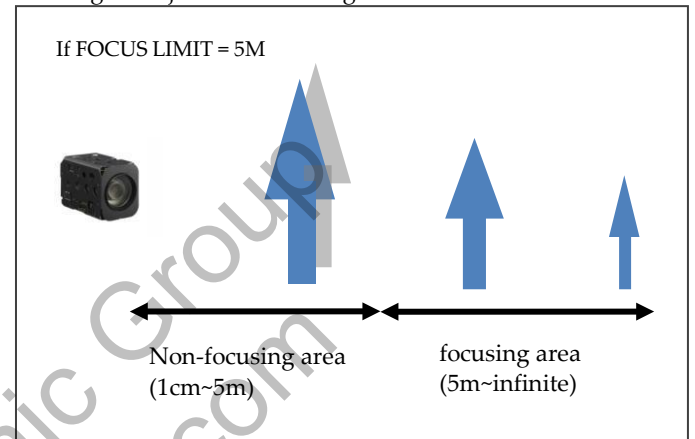

Auto Focus Mode

- AUTO
When a change in the image is detected, the AF operation is automatically performed.
- INTERVAL
It is used for AF movements carried out at particular intervals.
- MANUAL
Adjust zoom and focus manually.
- ONESHOT
When the zoom is changed, auto focus is executed only once.
The AF range is from FOCUS LIMIT to infinity.
It is called by "ONE PUSH" or "ZOOM TRIGGER" mode.
- PRESET
Always focus on the specified subject. When the zoom is changed, auto focus is executed only once. The AF range (=PRESET MARGIN) is limited to a specific range.

Home Position Mode

After power on, you can choose whether to move to the last position before power off or to x1 position.

KT_HomePowerOn	On	8x 01 70 24 02 FF	Moving to x1 position
	Off	8x 01 70 24 03 FF	Move to final position before power off

Automatic Exposure Mode

- Full Auto mode
Iris, Gain, Shutter speed can be set automatically.
- Shutter Priority mode
Variable shutter speed : 1/1(X32)~1/10000
Auto Iris & Gain
- Iris Priority mode
Variable Iris : F1.6 ~ Close, 14steps
Auto Gain & Shutter
- Manual mode
Variable Iris/Shutter/Gain
- AE Mode : AUTO/IRIS.PRI/SHUT.PRI/AGC.PRI/MANUAL

MODE	AUTO	IRIS.PRI	SHUT.PRI	AGC.PRI	MANUAL
SHUTTER	X	X	O	X	O
IRIS	X	O	X	X	O
AGC	X	X	X	O	O
AGC MAX	O	O	O	X	X
FLICKERLESS	O	O	X	O	X
SENS UP MAX	O	O	X	O	X
AE RESPONSE	O	X	X	X	X

(NOTE) See "Command Setting Values"

Exposure Compensation

It is a function which offsets the internal reference brightness level used in the AE mode.

CAM_ExpComp	8x 01 04 4E 00 00 0p 0q	pq=compensation level FF
-------------	-------------------------	-----------------------------

(NOTE) See "Command Setting Values"

Wide Dynamic Range (WDR)

Images with WDR are produced by combining long-exposure signals(normal shutter) with the signal of the high-intensity portions obtained a short-exposure (high-speed shutter).



WDR OFF

WDR ON

Back-Light Compensation(BLC)

BLC allows the camera to adjust the exposure of the entire image to properly expose the subject in the foreground.



BLC OFF

BLC ON

High-Light Compensation (HLC)

It's ability to reverse bright points in the picture to black. As an effective approach to recognize vehicle plate number at night, HLC function can detect any spotlight diffused by object-vehicle and compensate it for obtaining clearer image.

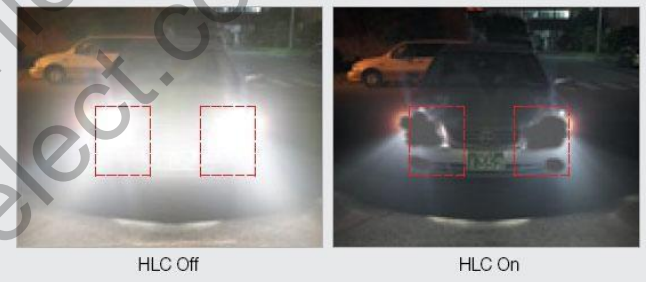

HLC Off

HLC On

Digital WDR

Digital Wide Dynamic Range gives the camera the ability to view Dark areas of the given image as well as extremely lighted portions of the image, or areas of high contrast.

KT_DwdrMode	8x 01 70 4B 0p FF	p=0(OFF) 1(ON), 2(AUTO)
KT_DwdrOnLevel	8x 01 70 4C 0p FF	p=0~16
KT_DwdrAutoLevel	8x 01 70 4D 0p FF	p=0(HIGH)~2(LOW)

White Balance

There is a difference between the colors that people perceive and the colors that the camera recognizes. White Balance is used to overcome or reduce the difference.

■ WD Mode

CAM_WB	Auto	8x 01 04 35 00 FF	Normal Auto
	Indoor	8x 01 04 35 01 FF	Indoor mode
	Outdoor	8x 01 04 35 02 FF	Outdoor mode
	OnePushWB	8x 01 04 35 03 FF	One Push WB mode
	ATW	8x 01 04 35 04 FF	ATWmode
	Manual	8x 01 04 35 05 FF	Manual mode

● AUTO

Automatically adjusts color. Setting offset-blue and offset-red(0~50).

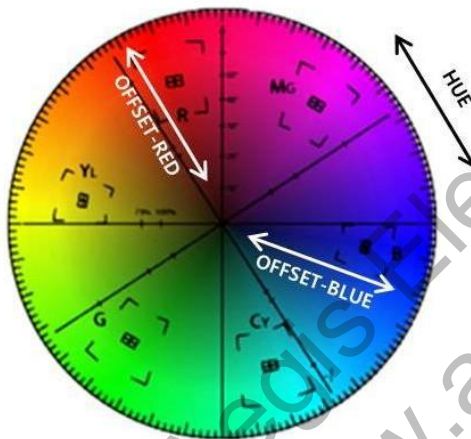

KT_WbBlueoffset	-	8x 01 71 51 pp FF	pp : Blue offset (0x00-0x64)
KT_WbRedoffset	-	8x 01 71 52 pp FF	pp : Red offset (0x00-0x64)

● ONE PUSH

Fix the color if pressed PUSH button

● INDOOR / OUTDOOR

Set color temperature to be indoor/outdoor light.

● ATW

Auto Trace White balance

● MANUAL

Adjust color manually. Setting blue gain and red gain(0~255).

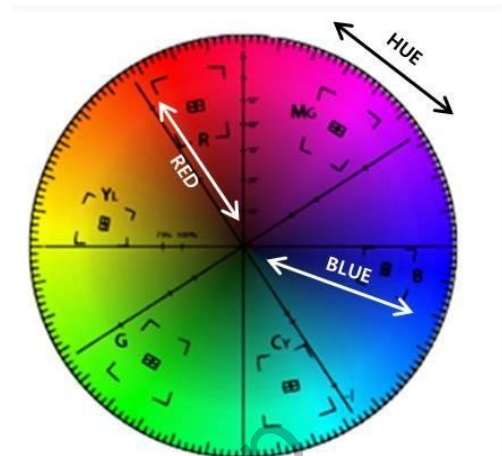

CAM_RGain	Reset	8x 01 04 03 00 FF	Manual
	Up	8x 01 04 03 02 FF	Control of R Gain
	Down	8x 01 04 03 03 FF	
	Direct	8x 01 04 43 00 00 0p 0q FF	pq: R Gain, 0x00-0xff
CAM_BGain	Reset	8x 01 04 04 00 FF	Manual
	Up	8x 01 04 04 02 FF	Control of B Gain
	Down	8x 01 04 04 03 FF	
	Direct	8x 01 04 44 00 00 0p 0q FF	pq: B Gain, 0x00-0xff

Day & Night Setting

Day&Night Mode

CAM_ICR	8x 01 04 01 0p FF	p=2(ICR ON) p=3(ICR OFF)
CAM_AutoICR	8x 01 04 51 0p FF	p=2(Auto ICR ON) p=3(Auto ICR OFF)

Mode	CAM_AutoICR	CAM_ICR
Day	OFF	OFF
Night	OFF	ON
Auto	ON	Don't care

You can select D & N mode in more detail.

CAM_ICR_Ext	8x 01 04 01 pp FF	pp=02 : ICR ON pp=03 : ICR OFF pp=20 : Auto pp=21 : Day pp=22 : Night pp=23 : Ext-H pp=24 : Ext-L
-------------	-------------------	---

AUTO Mode

If the current illumination is darker than the ICR ON level, the IR cut filter is removed. If it is brighter than the ICR OFF level, the IR cut filter is enabled.
ICR ON level = Day To Night level
ICR OFF level = Night To Day level

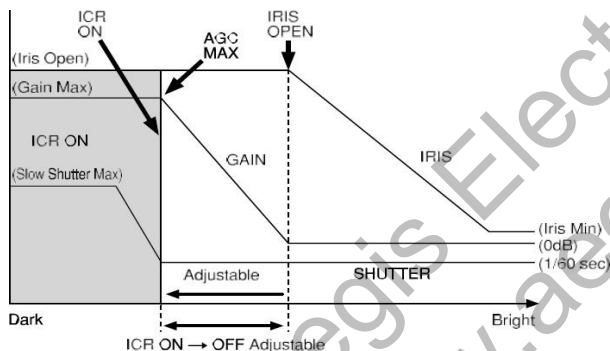

CAM_AutoICR_Threshold	8x 01 04 21 00 00 0p 0q FF	pq:ICR ON->OFF threshold level
KT_AutoICR_Threshold	8x 01 04 41 00 00 0p 0q FF	pq:ICR OFF->ON threshold level
KT_DwellTime	8x 01 04 41 01 00 0p 0q FF	pq:1~60 seconds

DAY Mode (=ICR OFF fixed)

It always maintains the DAY (color) state regardless of the current illumination.

NIGHT Mode (=ICR ON fixed)

It always maintains the NIGHT (B/W) state regardless of the current illumination.

EXT-L/H Mode

DAY / NIGHT is determined according to the external input signal.

In EXT-H mode, when the input signal level is greater than DAY TO NIGHT LEVEL, it switches to NIGHT.

In EXT-L mode, if the input signal level is lower than DAY TO NIGHT LEVEL, it switches to NIGHT.

KT_ExtICRthres hold	Day->Night(EXT-H)	8x 01 70 05 10 0p 0q FF
	Night->Day(EXT-H)	8x 01 70 05 11 0p 0q FF
	Day->Night(EXT-L)	8x 01 70 05 20 0p 0q FF
	Night->Day(EXT-L)	8x 01 70 05 21 0p 0q FF

CVBS Color Burst

Set color burst on / off of CVBS output signal.

However, it is applicable only at night.

KT_CvbsColorBurst	8x 01 70 13 0p FF	p=2 (color burst on at night) 3(color burst off at night)
-------------------	-------------------	--

Dwell Time

Set the day / night switching time. It is used for day/night switching in D & N Auto / ext-H / ext-L mode.

KT_DwellTime	8x 01 04 41 01 00 0p 0q FF	pq:1~60 seconds
--------------	----------------------------	-----------------

Night color

In night mode, color images can be viewed instead of black and white images.

KT_NightColor	8x 01 70 A2 0p FF	p=0 : BW image @ night p=1 : Color image @ night
---------------	-------------------	---

Noise Reduction

3D-NR, 2D-NR, 3D+2D NR

CAM_NR	8x 01 04 53 0p FF	p=0(off), level 1~5 (2D+3D) p=6 : 2D+3DNR auto mode
KT_DnrMode	8x 01 70 36 0p FF	p : DNR mode 0(Off)/1(2D)/2(3D)/3(2D+3D)
KT_DnrLevel	8x 01 70 39 0p 0q FF	p : DNR level 0(auto) 1(low)~3(high) q : DNR aperture 0~4

DNR aperture

- 0 : least aperture : most motion artifact
- 1 : less aperture : more motion artifact
- 2 : Normal aperture : normal motion artifact
- 3 : more aperture : less motion artifact
- 4 : most aperture : least motion artifact

Defog

- Sharpens cloudy images such as fog.

CAM_Defog	8x 01 04 37 0p 00 FF	p=2(ON) / 3(OFF) / 4(AUTO)
KT_DefogOnLevel	8x 01 70 3C 0p 00 FF	p=0~16 (defog ON mode level)
KT_DefogAutoLevel	8x 01 70 3D 0p 0q FF	p=0~2 (defog Auto mode level) q=0~3(defog Auto mode threshold)

Spot AE

- Available in Full Auto AE mode.
- A particular section of the subject can be designated, and then that portion of the image can be weighted and a value computed so that iris and gain can be optimized to obtain an image.

0	1	2	3	4	5	6	7	8	9	A	B	C	D	E	F
1															
2															
3															
4															
5															
6															
7															
8															
9															
A															
B															
C															
D															
E															
F															

CAM_SpotAE	On	8x 01 04 59 02 FF	Spot AE mode
	Off	8x 01 04 59 03 FF	
	Position	8x 01 04 29 0p 0q 0r 0s FF	pq:X(0~F), rs:Y(0~F)

Slow AE Response

The Slow AE Response function allows you to reduce the exposure response speed. (example) If the headlights of a car are caught by the camera, the camera automatically adjusts the exposure so that it can shoot a high-intensity subject. Since AE responds slowly, it can prevent images from being shot.

CAM_AE_Response	8x 01 04 5D pp FF	pp: 01 to 30 default 01
-----------------	-------------------	----------------------------

Digital Image Stabilizer (DIS)

- This function reduces image blurring caused by vibration
- CVBS is turned off when DIS mode is ON.



(before)

(after)

CAM_Stablizer	8x 01 04 34 0p FF	p=2 (ON), 3(OFF)
---------------	-------------------	------------------

PIP (Picture In Picture)

- Displays a small image on the image.
- CVBS is turned off when PIP mode is ON.



KT_PipSet	8x 01 70 48 0p 0q 0s 0r FF p=2 : PIP ON p=3 : PIP OFF p=F : Initialize PIP mode/size/position q=0~3 : pip window size 0(1/4),1(1/9),2(1/16),3(1/24) s=0~A : PIP window position - X r=0~A : PIP window position - Y
KT_PipSetInq	8x 01 70 48 FF y0 50 0p 0q 0s 0r FF

(*) default : p=3, q=1, s=A, r=A

Image Mirror

This function rotates the image.



(off)

(H-flip)

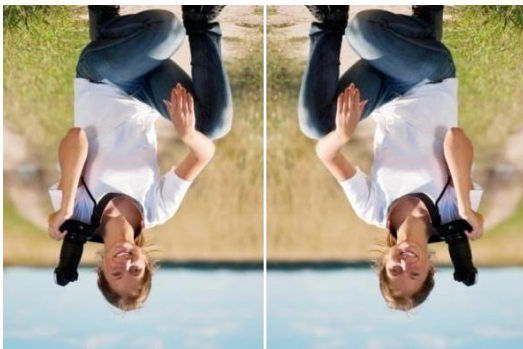

(V-flip)

(H/V-flip)

CAM_PictureFlip (180° rotation)	8x 01 04 66 0p FF	p=2(ON) 3(OFF)
CAM_LR_Reverse	8x 01 04 61 0p FF	p=2(ON) 3(OFF)

Mirror Mode	CAM_PictureFlip	CAM_LR_Reverse
Off	OFF	OFF
H-flip	OFF	ON
V-flip	ON	ON
H/V-flip	ON	OFF

KT_ImageRotate (corridor & mirror)	8x 01 70 4A 0p 0q FF	p=corridor mode 0(Off) 1(Full) 2(Crop) q=mirror mode 0(Off) 1(H-flip) 2(V-flip) 3(HV-flip)
---------------------------------------	----------------------	--

Corridor View

In many surveillance situations you want to monitor an area that is more vertical than horizontal in shape. This includes staircases, hallways, aisles, roads, runways, tunnels, and many other applications. In these situations, the traditional landscape format is not the optimal solution since it creates video streams where a large part of the field of view – specifically the sides of the image – is redundant.



(Original Image)

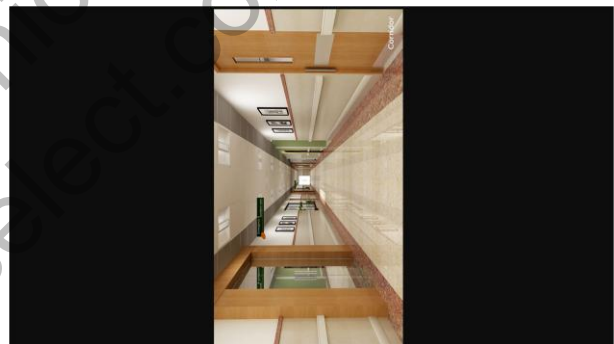

(Corridor Full mode)

The original picture is output.

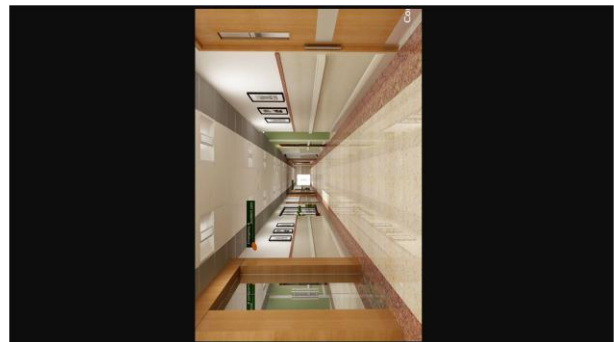

(Corridor Crop mode)

Corridor Crop mode is also known as 1: 1 mode. The original picture may not be output at all.

Freeze

This function captures an image in the field memory of the camera so that this image can be output continuously.

CAM_Freeze	On	8x 01 04 62 02 FF	Still Image ON/OFF
	Off	8x 01 04 62 03 FF	

Memory Preset

16 sets of camera shooting conditions can be stored and recalled.

- Zoom Position
- Digital Zoom Mode
- Focus Mode
- AE mode
- Shutter control parameters
- Bright , Iris, Gain
- Exposure Compensation mode
- Exposure Level
- Backlight Compensation mode
- Auto Slow Shutter On/Off
- White Balance mode
- Red/Blue Gain
- Aperture Control
- ICR mode, Defog, WDR mode

CAM_Memory	Reset	8x 01 04 3F 00 0p FF	p:Memory Number(0-F)
	Set	8x 01 04 3F 01 0p FF	
	Recall	8x 01 04 3F 02 0p FF	

(See. Custom/Memory Preset Setting Items)

Custom Preset

As with the memory preset function, the camera shooting conditions can be saved and recalled. The settings are recalled when the power is turned on.

- The above memory preset contents
- Privacy mask, Motion detect , Title
- Flip, mirror, negative, BW, Gamma, DNR, DIS, AF controls, camera ID, HLC, ETC.

CAM_Custom	Reset	8x 01 04 3F 00 7F FF	Starts up in this mode when the power is turned on
	Set	8x 01 04 3F 01 7F FF	
	Recall	8x 01 04 3F 02 7F FF	
	Inactive	8x 01 04 3F 10 7F FF	
	Active	8x 01 04 3F 11 7F FF	

(See. Custom/Memory Preset Setting Items)

(NOTE)

You can decide whether to use a custom preset.

When the product is shipped, custom preset is disabled(inactive mode)

To enable the custom preset, the user must send **SET/RECALL** or **ACTIVE** command.

To disable the custom preset, send **INACTIVE** command.

<Custom Preset Mode>

When the power is turned on,

- **Active** : starts up in the custom preset settings

- **Inactive** : starts up in the settings before the power is turned off

(factory shipment default : Inactive mode)

User Memory Area

You can use up to 16 bytes to store data such as camera number.

Position Preset

The current zoom / focus position can be stored in the internal memory and moved to that position if necessary. A total of 256 locations can be stored.

KT_ZoomFocus Preset	Set	8x 01 70 3F 01 0p 0q 0r FF	pqr : preset Number (0x000-0x0FF)
	Recall	8x 01 70 3F 02 0p 0q 0r FF	
	Clear	8x 01 70 3F 03 0p 0q 0r FF	
	Clear All Preset	8x 01 70 3F 0F 00 00 00 FF	Clear all preset data
KT_ZoomFocus PresetInq	8x 09 703F 0n 0n 0n FF	y0 50 0v 0z 0z 0z 0z 0f 0f 0f 0f FF	nnn: preset number (0x000-0x0FF) v : 1(saved), 0(empty) zzzz : zoom position ffff : focus position

Motion Detect Function

Motion Detect functions instructs the camera to detect movement within monitoring area and then send an alarm signal automatically.

◇ Frame

You can set up to 4-frames

Each frame can be set up :

Using VISCA : 16 (horizontally)×8 (vertically) blocks

Using MENU : 60 (horizontally)×34 (vertically) blocks

◇ Sending Alarms

- When motion is detected, the Alarm Replay command is issued via the serial command (VISCA) communication line.
- When multiple motions are detected or motion is detected in another frame within the set interval following the original time the alarm was issued, another alarm command is not issued.
- When motion is detected after the interval time elapsed, the alarm is issued again.

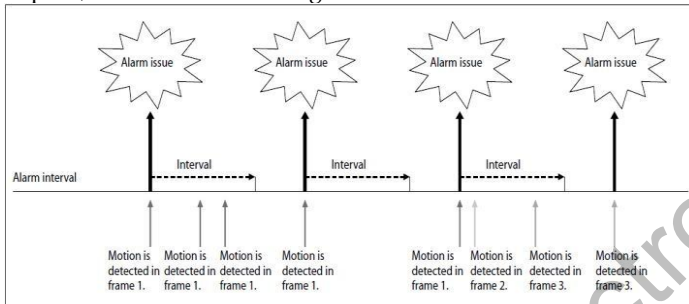

On	8x 01 04 1B 02 FF	Motion Detection On/Off
Off	8x 01 04 1B 03 FF	
Function Set	8x 01 04 1C 0m 0n 0p 0q 0r 0s FF	m: Display mode (when motion is detected) bit0 : frame display bit1 : block display bit2 : Text display n: Detection Frame Set (0 to F) bit0(frame1)-bit3(frame4) pq: Threshold Level (00 to FF) rs: Interval Time set (00 to FF)
Window Set	8x 01 04 1D 0m 0p 0q rr 0s FF	m: Select Detection Frame (0, 1, 2, 3) p: Start Horizontal Position (00 to 0F) q: Start Vertical Position (00 to 07) r: Stop Horizontal Position (01 to 10) s: Stop Vertical Position (01 to 08)
Alarm (Reply)	y0 07 04 1B 0p FF	p: Detection Frame Number

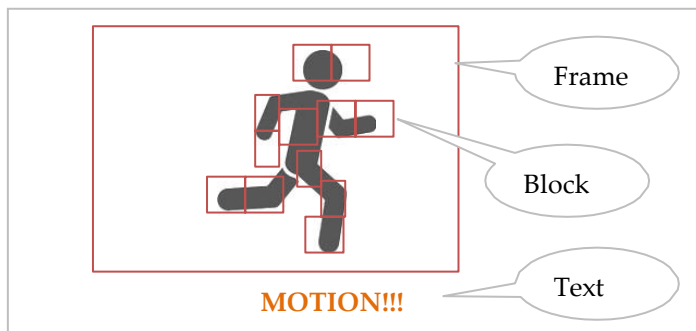

(*) Blocks are output only within the Frame area.

Title / Function Display

The user can output desired characters on the screen and can also choose the output font size.

See. "CAM_Title", "CAM_MultiLineTitle", "CAM_EvenLineTitle"

Normal Size : 19 lines, 43 columns

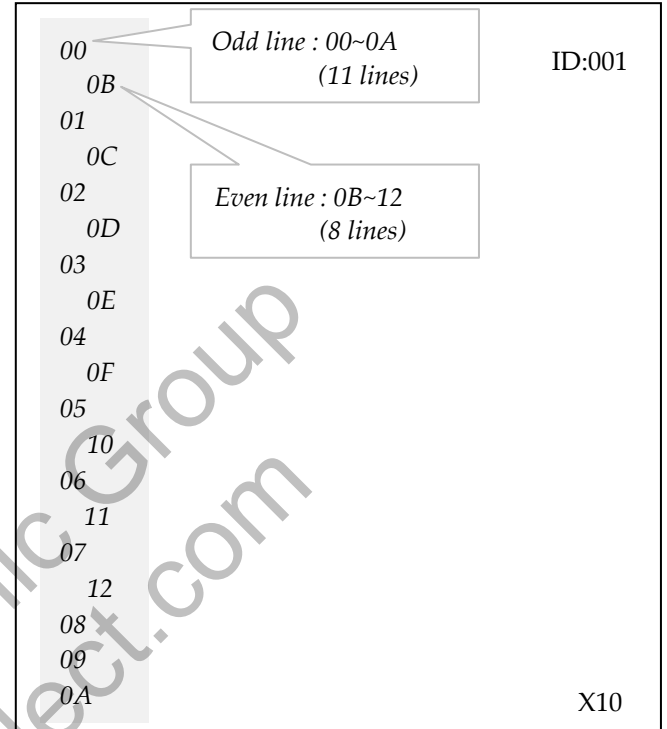

System Reset

Initialize most camera states.

Several important values are not initialized. (ex. Framerate, Baudrate, Trigger, LVDS mode, CVBS Aspect, Color Adjust Data, Picture Style, etc.)

KT_FactoryDefault	8x 01 70 EE EE FF
-------------------	-------------------

Initializes the entire system to the factory default.

All values are initialized.

Be careful(!!!)

KT_FactoryDefSystem	8x 01 70 EF EF FF
---------------------	-------------------

Privacy Zone Masking

Privacy Zone masking protects private objects and areas such as house windows, entrances, and exits which are within the camera's range of vision but not subject to surveillance. Privacy zone masking can be masked on the monitor to protect privacy.

- Mask can be set on up to 8 places according to Pan/Tilt positions.
- Interlocking control with zooming.
- Interlocking control with Pan/Tilt.
- Non-interlocking control with Pan/Tilt.

Command Set	Command	Command	Comments
CAM_PrivacyZone	SetMask	8x 01 04 76 mm nn 0r 0r 0s 0s FF	Setting Mask(Size) See "mm: Mask setting list", "nn: Setting", and "rr: w, ss: h" in "Parameters"
	Display	8x 01 04 77 pp pp pp pp FF	Setting Mask Display On/Off See "pp pp pp pp: Mask bit" in "Parameters" . pp pp pp pp: Mask setting (0: OFF, 1: ON)
	SetMaskColor	8x 01 04 78 pp pp pp pp qq rr FF	Setting Color of Mask See "pp pp pp pp: Mask bit" and "qq, rr: Color code" in "Parameters". qq: Color setting when setting the Mask bit to 0 rr: Color setting when setting the Mask
	SetPanTiltAngle	8x 01 04 79 0p 0p 0p 0q 0q 0q FF	Setting Pan/Tilt Angle See "Setting pan/tilt angle" in "Parameters". ppp: Pan angle, qq: Tilt angle
	SetPTZMask	8x 01 04 7B mm 0p 0p 0p 0q 0q 0q 0r 0r 0r 0r FF	Setting the direct position of PTZ See "mm: Mask setting list" and "Setting pan/tilt angle" in "Parameters". ppp: Pan , qq: Tilt , rrr: Zoom
	Non_InterlockMask	8x 01 04 6F mm 0p 0p 0q 0q 0r 0r 0s 0s FF	Setting non-interlocking the mask to pan/tilt See "mm: Mack setting list" and "pp:x,qq:y, rr:w, ss:

Inquiry Command	Command Packet	Inquiry Packet	Comments
CAM_PrivacyDisplayInq	8x 09 04 77 FF	y0 50 pp pp pp pp FF	Inquiry about the status of Setting Mask Display On/ Off See "pp pp pp pp: Mask bit" in "Parameters" . 1:On,0:Off
CAM_PrivacyPanTiltInq	8x 09 04 79 FF	y0 50 0p 0p 0p 0q 0q 0q FF	Inquiry about the pan/tilt position currently set See "Setting pan/tilt angle" in "Parameters". ppp: Pan, qq: Tilt
CAM_PrivacyPTZInq	8x 09 04 7B mm FF	y0 50 0p 0p 0p 0q 0q 0q 0r 0r 0r 0r FF	Inquiry about pan/tilt/zoom position at the mm Mask setting See "mm: Mask setting list" and "Setting pan/tilt angle" in "Parameters". ppp: Pan osition, qqq: Tilt Position rrr: Zoom
CAM_PrivacyMonitorInq	8x 09 04 6F FF	y0 50 pp pp pp pp FF	Inquiry about the mask currently displayed See "pp pp pp pp: Mask bit" in "Parameters".

- Mask Number : A=0x00, B=0x01,...W=0x16, X=0x17 (total 24 masks)
- Mask Bit & Mask List(mm)

	pp pp pp pp (mask bit) or mm(Mask list)																																	
byte	pp								pp								pp								pp									
bit	7	6	5	4	3	2	1	0	7	6	5	4	3	2	1	0	7	6	5	4	3	2	1	0	7	6	5	4	3	2	1	0		
Mask	-	-	-	-	-	-	-	-	-	-	-	-	-	-	-	-	-	-	-	-	-	-	-	-	H	G	-	-	F	E	D	C	B	A
List(mm)																									07	06			05	04	03	02	01	00

The priority order of the mask display is in the sequence from A (highest) to P (lowest).

● Pan/Tilt Angle

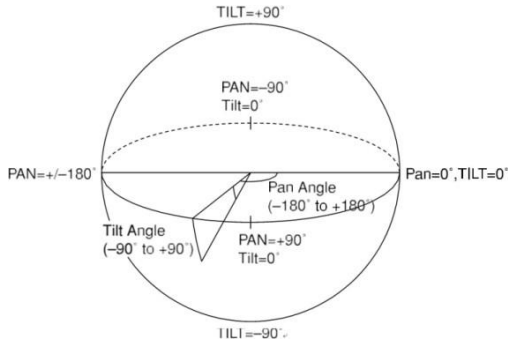
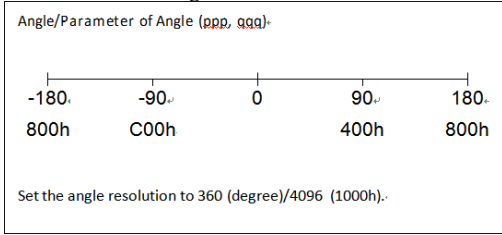

- ✓ You can use the tilt angle at which you can set the mask between -90 to + 90 degrees. But the recommended tilt angle is between -70 to +70 degrees.
- ✓ It is recommended that you set the size to at least twice the size of the object (height and width).

● Mask Color (qq, rr)

Mask (Color)	Normal	Translucence
Black	00h	10h
Gray1	01h	11h
Gray2	02h	12h
Gray3	03h	13h
Gray4	04h	14h
Gray5	05h	15h
Gray6	06h	16h
White	07h	17h
Red	08h	18h
Green	09h	19h
Blue	0Ah	1Ah
Cyan	0Bh	1Bh
Yellow	0Ch	1Ch
Magenta	0Dh	1Dh

● Mask Size : Width/Height

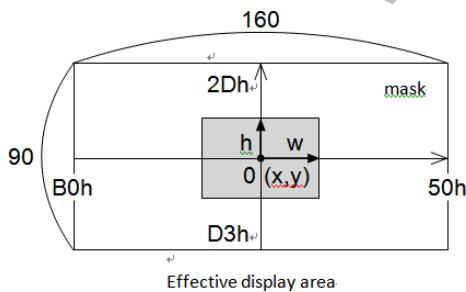

Eclipse

When designing the housing, refer to the dimensional allowance as shown in the figure below.

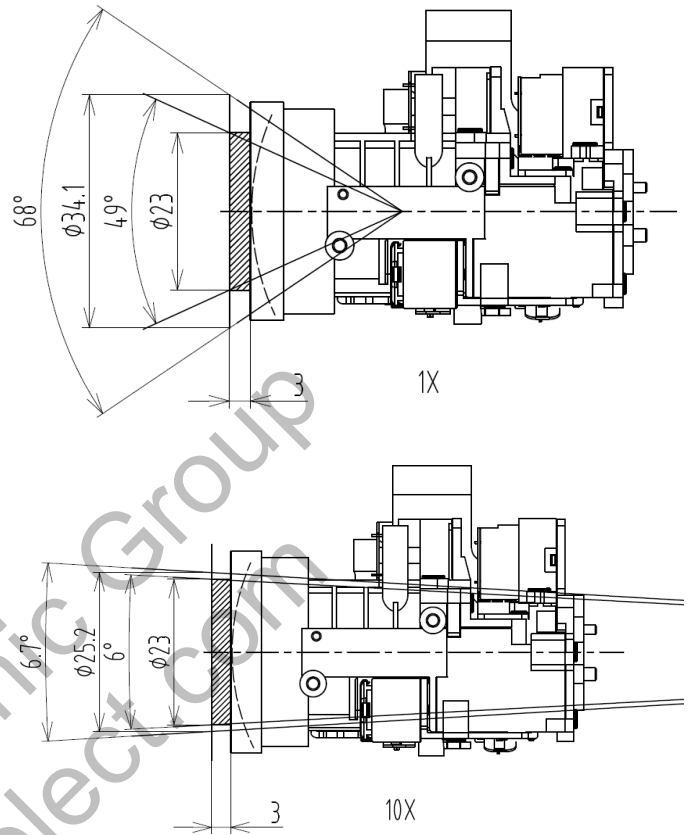

Spectral Sensitivity Characteristics

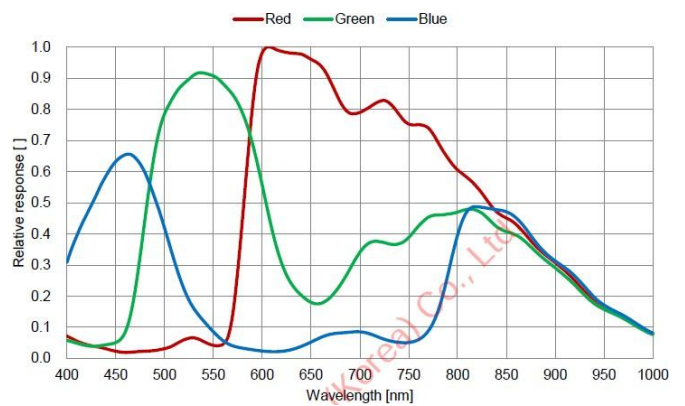

Use the graph as a reference value. We can not guarantee these values.

Video Output Mode

It is to set the angle of view range of the output video.

Sensor Scan	Output Video Scan	Output image
FULL	FULL	4:3
FULL	CROP	16:9
CROP	-	16:9

The image sensor we use is a 4: 3 ratio sensor.

(2064(H)x1544(V))

Camera can scan the image sensor in 4: 3 Full or 16: 9 Crop.



If the monitor to be used is a 4: 3 ratio monitor, it will show a wider angle of view when used in FULL/FULL mode.

If you use a monitor with 16: 9 ratio in FULL/FULL mode, the angle of view is not cropped, but the subject looks more fat.

In FULL/CROP or CROP/- mode, the image is narrower than the actual image captured by the image sensor. Only the 16: 9 CROP area shown in the figure above is output as the final image.

CAM_RegisterValue (Sensor Scan Mode)	8x 01 04 24 92 0p 0p FF	pp= 00 FULL scan 01 CROP scan
---	----------------------------	----------------------------------

★ It is not applied until the power is turned off and on.

★ To use the TRIGGER function, the sensor scan mode must be in FULL mode.

★ WDR can not be used in TRIGGER mode.

★ LVDS SET menu is only can be used on 1080p50 or 1080p60.

★ For more information, please use the reference materials.

Global Shutter

Global shutter make images that not distorted without wobble or skewing. This shutter uses visualize that object moving high speed.

COMMAND LIST

Overview of RS232 Communication

- Communication speed :
2400/4800/9600/19200,38400/57600/115200bps
- Data bits : 8
- Start bit : 1
- Stop bit : 1
- Non parity
- Flow control using XON/XOFF and RTS/CTS, etc., is not supported

Command & Inquiry

- **Command**
Sends operational commands to the camera
- **Inquiry**
Used for inquiring about the current state of the camera

	Command Packet	Note
Inquiry	8X QQ RR ... FF	QQ ₁) = Command/Inquiry, RR ₂) = category code
		1) QQ = 01 (Command), 09 (Inquiry)
		2) RR = 00 (Interface), 04 (camera 1), 06 (Pan/Tilter), 07 (camera 2)
		X = 1 to 7 : camera address

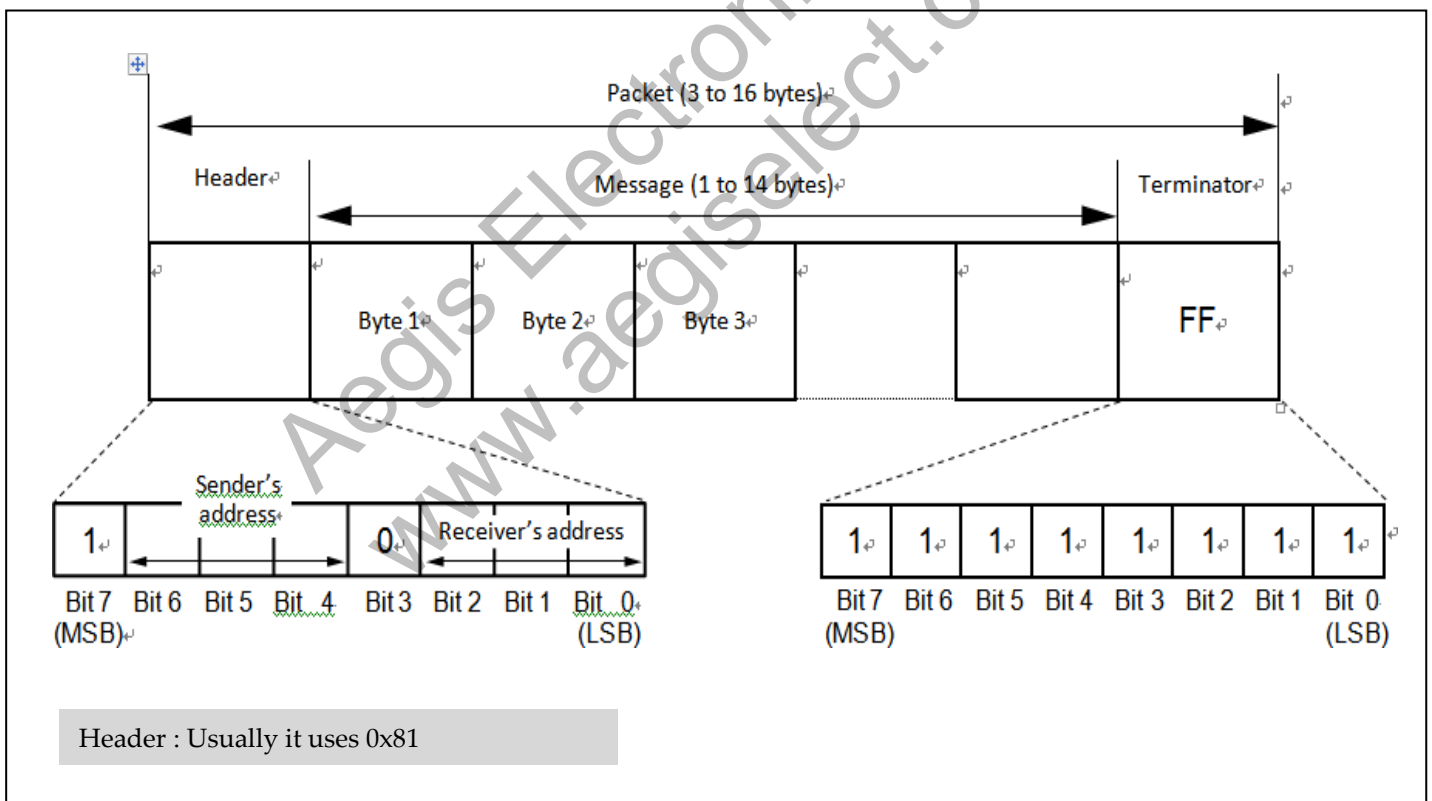

Inquiries

• ACK message

Returned by the camera when it receives a command. No ACK message is returned for inquiries.

• Completion message

Returned by the camera when execution of commands or inquiries is completed. In the case of inquiry commands, it will contain reply data for the inquiry after the 3rd byte of the packet. If the ACK message is omitted, the socket number will contain 0.

	Reply Packet	Note
Ack	X0 4Y FF	Y = socket
Completion	X0 5Y FF	Y = socket
Completion (Inquiries)	X0 5Y ... FF	Y = socket

X = 9 to F: camera address + 8

• Error message

Error Packet	Description
X0 6Y 01 FF	Message length error (>14 bytes)
X0 6Y 02 FF	Syntax Error
X0 6Y 03 FF	Command Buffer Full
X0 6Y 04 FF	Command cancelled
X0 6Y 05 FF	No socket
X0 6Y 41 FF	Command not executable

X = 9 to F: camera address + 8, Y = socket number

• Cam_VersionInq

Returns information on the VISCA interface.

Inquiry	Packet	Reply	Description
Cam_VersionInq	8X 09 00 02 FF	Y0 50 GG GG HH HH JJ JJ FF	GGGG=Vender ID HHHH=Model ID JJJJ = ROM version

X = 1 to 7 : camera address (For inquiry packet)

X = 9 to F : camera address +8 (For reply packet)

GGGG = 0x0055 (vendor=KTNC)

HHHH : Model Code

HZ5530W : 0467 (I.B.D → It will be changed)

JJJJ : ex) 0123 = Ver1.2.3

• Network change

Camera automatically transmits when power is turned on.

Packet

Network change X0 38 FF (X=9)

Command / ACK Example

Command	Command Message	Reply Message	Comments
General Command	81 01 04 38 02 FF (Example)	90 41 FF (ACK)+90 51 FF (Completion) 90 42 FF 90 52 FF	Returns ACK when a command has been accepted, and Completion when a command has been executed.
	81 01 04 38 FF (Example)	90 60 02 FF (Syntax Error)	Accepted a command which is not supported or a command lacking parameters.
	81 01 04 08 02 FF (Example)	90 61 41 FF (Command Not Executable) 90 62 41 FF	Could not execute the command in the current mode.
Inquiry Command	81 09 04 38 FF (Example)	90 50 02 FF (Completion)	ACK is not returned for the inquiry command.
	81 09 05 38 FF (Example)	90 60 02 FF (Syntax Error)	Accepted an incompatible command.
Address Set	88 30 01 FF	88 30 02 FF	Returned the device address to +1.
IF_Clear (Broadcast)	88 01 00 01 FF	88 01 00 01 FF	Returned the same command.
IF_Clear (For x)	8x 01 00 01 FF	z0 50 FF (Completion)	ACK is not returned for this command.

CAMERA COMMAND LIST

Command Set	Command	Command Packet	Comments	
AddressSet	Broadcast	88 30 01 FF	Address setting	
IF_Clear	Broadcast	88 01 00 01 FF	I/F Clear	
CommandCancel	-	8x 2p FF	p: Socket No. (=1 or 2)	
CAM_Power	On	8x 01 04 00 02 FF	Power ON/OFF	
	Off (Standby)	8x 01 04 00 03 FF		
CAM_Zoom	Stop	8x 01 04 07 00 FF	p=0 (Low) to 7 (High) pqrs: Zoom Position zzzz : zoom position ffff : focus position	
	Tele (Standard)	8x 01 04 07 02 FF		
	Wide (Standard)	8x 01 04 07 03 FF		
	Tele (Variable)	8x 01 04 07 2p FF		
	Wide (Variable)	8x 01 04 07 3p FF		
	Direct	8x 01 04 47 0p 0q 0r 0s FF		
	Direct Zoom/Focus	8x 01 04 47 0z 0z 0z 0z 0f 0f 0f 0f FF		
CAM_DZoom	On	8x 01 04 06 02 FF	Digital zoom ON/OFF	
	Off	8x 01 04 06 03 FF		
	Combine Mode	8x 01 04 36 00 FF	Optical/Digital Zoom Combined	
	Separate Mode	8x 01 04 36 01 FF	Optical/Digital Zoom Separate	
	Stop	8x 01 04 06 00 FF		
	Tele (Variable)	8x 01 04 06 2p FF	p=0 (Low) to 7 (High)	
	Wide (Variable)	8x 01 04 06 3p FF	* Enabled during Separate Mode	
	x1/Max	8x 01 04 06 10 FF	x1/MAX Magnification Switchover * Enabled during Separate Mode	
	Direct	8x 01 04 46 00 00 0p 0q FF	pq: D-Zoom Position * Enabled during Separate Mode	
CAM_Focus	Stop	8x 01 04 08 00 FF	p=0 (Low) to 7 (High) pqrs: Focus Position AF ON/OFF	
	Far (Standard)	8x 01 04 08 02 FF		
	Near (Standard)	8x 01 04 08 03 FF		
	Far (Variable)	8x 01 04 08 2p FF		
	Near (Variable)	8x 01 04 08 3p FF		
	Direct	8x 01 04 48 0p 0q 0r 0s FF		
	Auto Focus	8x 01 04 38 02 FF		
	Manual Focus	8x 01 04 38 03 FF		
	Auto/Manual	8x 01 04 38 10 FF		
	One Push Trigger	8x 01 04 18 01 FF		One Push AF Trigger
	Infinity	8x 01 04 18 02 FF		Forced infinity
Near Limit	8x 01 04 28 0p 0q 0r 0s FF	pqrs: Focus Near Limit Position		
AF Sensitivity	High	8x 01 04 58 02 FF	AF Sensitivity High/Low	
	Low	8x 01 04 58 03 FF		
CAM_AFMode	Auto	8x 01 04 57 00 FF	AF Movement Mode	
	Interval	8x 01 04 57 01 FF		
	Oneshot	8x 01 04 57 02 FF		
	Preset	8x 01 04 57 03 FF		
CAM_IRCorrection	Standard	8x 01 04 11 00 FF	FOCUS IR compensation data switching	
	IR Light	8x 01 04 11 01 FF		
CAM_ZoomFocus	Direct	8x 01 04 47 0p 0q 0r 0s 0t 0u 0v 0w FF	pqrs: Zoom Position tuvw: Focus Position	
CAM_Initialize	Lens	8x 01 04 19 01 FF	Lens Initialization Start	
	Camera	8x 01 04 19 03 FF	Camera reset	
CAM_WB	Auto	8x 01 04 35 00 FF	Normal Auto	
	Indoor	8x 01 04 35 01 FF	Indoor mode	
	Outdoor	8x 01 04 35 02 FF	Outdoor mode	
	One Push WB	8x 01 04 35 03 FF	One Push WB mode	
	ATW	8x 01 04 35 04 FF	Auto Tracing White Balance	
	Manual	8x 01 04 35 05 FF	Manual Control mode	
CAM_RGain	One Push Trigger	8x 01 04 10 05 FF	One Push WB Trigger	
	Reset	8x 01 04 03 00 FF	Manual Control of R Gain	
	Up	8x 01 04 03 02 FF		
Down	8x 01 04 03 03 FF			

	Direct	8x 01 04 43 00 00 0p 0q FF	pq: R Gain, 0x00-0xff
CAM_BGain	Reset	8x 01 04 04 00 FF	Manual Control of B Gain
	Up	8x 01 04 04 02 FF	
	Down	8x 01 04 04 03 FF	
	Direct	8x 01 04 44 00 00 0p 0q FF	
CAM_AE	Full Auto	8x 01 04 39 00 FF	Automatic Exposure mode
	Manual	8x 01 04 39 03 FF	Manual Control mode
	Shutter Priority	8x 01 04 39 0A FF	Shutter Priority Automatic Exposure mode
	Iris Priority	8x 01 04 39 0B FF	Iris Priority Automatic Exposure mode
	Bright	8x 01 04 39 0D FF	Bright Mode (Manual control)
CAM_SlowShutter	Auto	8x 01 04 5A 02 FF	Auto Slow Shutter ON/OFF
	Manual	8x 01 04 5A 03 FF	
CAM_Shutter	Reset	8x 01 04 0A 00 FF	Shutter Setting
	Up	8x 01 04 0A 02 FF	
	Down	8x 01 04 0A 03 FF	
	Direct	8x 01 04 4A 00 00 0p 0q FF	
CAM_Iris	Reset	8x 01 04 0B 00 FF	Iris Setting
	Up	8x 01 04 0B 02 FF	
	Down	8x 01 04 0B 03 FF	
	Direct	8x 01 04 4B 00 00 0p 0q FF	
CAM_Gain	Reset	8x 01 04 0C 00 FF	Gain Setting
	Up	8x 01 04 0C 02 FF	
	Down	8x 01 04 0C 03 FF	
	Direct	8x 01 04 4C 00 00 0p 0q FF	
	Gain Limit	8x 01 04 2C pp FF	
CAM_Bright	Reset	8x 01 04 0D 00 FF	Bright Setting
	Up	8x 01 04 0D 02 FF	
	Down	8x 01 04 0D 03 FF	
	Direct	8x 01 04 4D 00 00 0p 0q FF	
CAM_ExpComp	On	8x 01 04 3E 02 FF	Exposure Compensation ON/OFF
	Off	8x 01 04 3E 03 FF	
	Reset	8x 01 04 0E 00 FF	Exposure Compensation Amount Setting
	Up	8x 01 04 0E 02 FF	
	Down	8x 01 04 0E 03 FF	
	Direct	8x 01 04 4E 00 00 0p 0q FF	
CAM_BackLight	On	8x 01 04 33 02 FF	Back Light Compensation ON/OFF
	Off	8x 01 04 33 03 FF	
CAM_AE_Response	Direct	8x 01 04 5D pp FF	pp: Automatic Exposure Response Setting (01 to 30), default value: 01
CAM_WDR	On	8x 01 04 3D 02 FF	WDR On/Off
	Off	8x 01 04 3D 03 FF	
CAM_WDRPara	Direct	8x 01 04 2D 00 0p 0q 0r 00 00 00 00 FF	
CAM_Aperture (sharpness level)	Reset	8x 01 04 02 00 FF	Aperture Control (sharpness)
	Up	8x 01 04 02 02 FF	
	Down	8x 01 04 02 03 FF	
	Direct	8x 01 04 42 00 00 0p 0q FF	
CAM_HR	On	8x 01 04 52 02 FF	High-Resolution Mode ON/OFF
	Off	8x 01 04 52 03 FF	
CAM_NR	-	8x 01 04 53 0p FF	p: NR Setting (0: OFF, level 1 to 5)
CAM_Gamma	-	8x 01 04 5B 0p FF	p: Gamma setting (0: Standard, 1 to 6) See. GAMMA POSITION
CAM_HighSensitivity	On	8x 01 04 5E 02 FF	High Sensitivity mode ON/OFF
	Off	8x 01 04 5E 03 FF	
CAM_LR_Reverse	On	8x 01 04 61 02 FF	Mirror Image ON/OFF
	Off	8x 01 04 61 03 FF	
CAM_Freeze	On	8x 01 04 62 02 FF	Still Image ON/OFF
	Off	8x 01 04 62 03 FF	
CAM_PictureEffect	Off	8x 01 04 63 00 FF	Picture Effect Setting
	Neg.Art	8x 01 04 63 02 FF	
	B&W	8x 01 04 63 04 FF	
	ColorEffect	8x 01 04 63 1p FF	
CAM_PictureFlip	On	8x 01 04 66 02 FF	Picture flip ON/OFF
	Off	8x 01 04 66 03 FF	
CAM_ICR	On	8x 01 04 01 02 FF	Infrared Mode ON(night)/OFF(day)
	Off	8x 01 04 01 03 FF	

CAM_AutoICR	On	8x 01 04 51 02 FF	Auto dark-field mode On/Off
	Off	8x 01 04 51 03 FF	
	Threshold	8x 01 04 21 00 00 0p 0q FF	pq: ICR ON → OFF Threshold Level (Night->Day)
	Threshold	8x 01 04 41 00 00 0p 0q FF	pq: ICR OFF → ON Threshold Level (Day->Night)
CAM_AutoICRAAlarmReply	On	8x 01 04 31 02 FF	Auto ICR switching Alarm ON/OFF
	Off	8x 01 04 31 03 FF	
	(Reply)	y0 07 04 31 02 FF y0 07 04 31 03 FF	ICR OFF → ON (Night->Day) ICR ON → OFF (Day->Night)
CAM_MemSave	Write	8x 01 04 23 0X 0p 0p 0q 0q FF	X: 00 to 07 (Address), total 16 byte ppqq: 0x0000 to 0xFFFF (Data)
CAM_Display	On	8x 01 04 15 02 FF (8x 01 06 06 02 FF)	Display ON/OFF (function OSD display)
	Off	8x 01 04 15 03 FF (8x 01 06 06 03 FF)	Function OSD :
	On/Off	8x 01 04 15 10 FF (8x 01 06 06 10 FF)	- Display item : Zoom Ratio, Camera ID Framerate, AE mode, WB mode, Exposure Data
CAM_Title Total 19 lines See. "Title/Function display"	Title Set1	8x 01 04 73 00 mm nn pp qq 00 00 00 00 00 00 FF	mm : V-position(0x00-0x13) , nn:H-position (00-2B) pp:color, qq:blink
	Title Set2	8x 01 04 73 01 mm nn pp qq rr ss tt uu vv ww FF	mm-ww : setting of display characters (1st to 10st)
	Title Set3	8x 01 04 73 02 mm nn pp qq rr ss tt uu vv ww FF	mm-ww : setting of display characters (11st to 20st)
	Title Set4	8x 01 04 73 07 01 02 03 04 05 06 07 08 09 10 11 12 13 14 15 16 17 18 19 20 21 22 23 24 25 26 27 28 29 30 32 33 34 35 36 37 38 39 40 41 42 43 FF	mm-ww : setting of display characters (1~ 43)
	Title Clear	8x 01 04 74 00 FF	Title Setting Clear (clear all lines)
	On	8x 01 04 74 02 FF	Title Display On (display all lines)
	Off	8x 01 04 74 03 FF	Title Display Off (display off all lines)
	CAM_MultiLineTitle See. "Title/Function display" (Normal Font Odd Line) L = 0x0 = Line 00 0x1 = Line 01 ... 0x9 = Line 09 0xA = Line 0A	Title Set1	8x 01 04 73 1L 00 mm nn pp qq 00 00 00 00 00 00 FF
Title Set2		8x 01 04 73 2L mm nn pp qq rr ss tt uu vv ww FF	L: Line Number (0x0-0xA) mnpqrstuvw: Setting of characters (1 to 10)
Title Set3		8x 01 04 73 3L mm nn pp qq rr ss tt uu vv ww FF	L: Line Number (0x0-0xA) mnpqrstuvw: Setting of characters (11 to 20)
Title Set4		8x 01 04 73 7L 01 02 03 04 05 06 07 08 09 10 11 12 13 14 15 16 17 18 19 20 21 22 23 24 25 26 27 28 29 30 32 33 34 35 36 37 38 39 40 41 42 43 FF	L: Line Number (0x0-0xA) 01-43 : Setting of characters (1 to 43)
Title Clear		8x 01 04 74 1p FF	Title Clear, Display On/Off
On		8x 01 04 74 2p FF	p:0x0-0xA, F= all lines (line 00-0A)
Off		8x 01 04 74 3p FF	
CAM_EvenLineTitle See. "Title/Function display" (Normal Font Even Line) L = 0x0 = Line 0B 0x1 = Line 0C ... 07 = Line 12	Title Set1A	8x 01 04 73 4L 00 nn pp qq 00 00 00 00 00 00 FF	L: Line Number (0x0-0x7) nn: H-position → nn : 00-0x2B pp: Color, qq: Blink
	Title Set2A	8x 01 04 73 5L mm nn pp qq rr ss tt uu vv ww FF	L: Line Number (0x0-0x7) mnpqrstuvw: Setting of characters (1 to 10)
	Title Set3A	8x 01 04 73 6L mm nn pp qq rr ss tt uu vv ww FF	L: Line Number (0x0-0x7) mnpqrstuvw: Setting of characters (11 to 20)
	Title Set4A	8x 01 04 73 8L 01 02 03 04 05 06 07 08 09 10 11 12 13 14 15 16 17 18 19 20 21 22 23 24 25 26 27 28 29 30 32 33 34 35 36 37 38 39 40 41 42 43 FF	L: Line Number (0x0-0x7) 01-43 : Setting of characters (1 to 43)
	Title Clear	8x 01 04 74 4p FF	Title Clear, Display On/Off
	On	8x 01 04 74 5p FF	p:0x0-0x7, F= all lines (line 0B ~ 12)
	Off	8x 01 04 74 6p FF	
CAM_Mute	On	8x 01 04 75 02 FF	Muting ON/OFF
	Off	8x 01 04 75 03 FF	
	On/Off	8x 01 04 75 10 FF	
CAM_PrivacyZone	SetMask	8x 01 04 76 mm nn 0r 0r 0s 0s FF	mm: Mask Settings nn 00: Modify, 01: New rr: W, ss: H
	Display	8x 01 04 77 pp pp pp pp FF	Mask Display ON/OFF

			pp pp pp pp: Mask Settings (0: OFF, 1: ON)
	SetMaskColor	8x 01 04 78 pp pp pp pp qq rr FF	pp pp pp pp: Mask Color Settings qq: Color Setting when 0 is selected rr: Color Setting when 1 is selected
	SetPanTiltAngle	8x 01 04 79 0p 0p 0p 0q 0q 0q FF	Pan/Tilt Angle Settings ppp: Pan qqq: Tilt
	SetPTZMask	8x 01 04 7B mm 0p 0p 0p 0q 0q 0q 0r 0r 0r 0r FF	Pan/Tilt/Zoom Settings for Mask ppp: Pan, qq: Tilt, rrrr: Zoom
	Non_InterlockMask	8x 01 04 6F mm 0p 0p 0q 0q 0r 0r 0s 0s FF	mm: Non_Interlock Mask Settings pp: X, q: Y, rr: W, ss: H
CAM_IDWrite	—	8x 01 04 22 0p 0q 0r 0s FF	pqrs: Camera ID (=0000 to FFFF)
CAM_MD	On	8x 01 04 1B 02 FF	Motion Detection On/Off
	Off	8x 01 04 1B 03 FF	
	Function Set	8x 01 04 1C 0m 0n 0p 0q 0r 0s FF	m: Display mode (when motion is detected) bit0 : frame display bit1 : block display bit2 : Text display n: Detection Frame Set (0 to F) bit0(frame1)~bit3(frame4) pq: Threshold Level (00 to FF) rs: Interval Time set (00 to FF)
	Window Set	8x 01 04 1D 0m 0p 0q rr 0s FF	m: Select Detection Frame (0, 1, 2, 3) p: Start Horizontal Position (00 to 0F) q: Start Vertical Position (00 to 07) r: Stop Horizontal Position (01 to 10) s: Stop Vertical Position (01 to 08)
	Alarm (Reply)	y0 07 04 1B 0p FF	p: Detection Frame Number
CAM_Continuous ZoomPosReply	On	8x 01 04 69 02 FF	ZoomPosition data Continuous Output On/Off
	Off	8x 01 04 69 03 FF	
	(Reply)	y0 07 04 69 0p 0p 0q 0q 0q 0q FF	pp: D-Zoom Position * 00: When Zoom Mode is Combine qqqq: Zoom Position
CAM_ZoomPos ReplyIntervalTimeSet	—	8x 01 04 6A 00 00 0p 0p FF	pp: Zoom Position continuous output Interval Time [Vertical timing]
CAM_Continuous FocusPosReply	On	8x 01 04 16 02 FF	Focus Position data Continuous Output On/Off
	Off	8x 01 04 16 03 FF	
	(Reply)	y0 07 04 16 00 00 0p 0p 0p 0p FF	pppp: Focus Position
CAM_FocusPos ReplyIntervalTimeSet	—	8x 01 04 1A 00 00 0p 0p FF	pp: Focus Position continuous output Interval Time [Vertical timing]
CAM_ExtAutoICR_thresh old	ICR ON -> OFF	8x 01 04 1F 21 00 00 0p 0q FF	pq : ICR ON -> OFF threshold when Auto ICR is on pq = 00h ~ 1Bh (Night → Day threshold)
	ICR OFF -> ON	8x 01 04 1F 21 01 00 0p 0q FF	pq : ICR OFF -> ON threshold when Auto ICR is on pq = 01h ~ 1Ch (Day → Night threshold)
CAM_RegisterValue	—	8x 01 04 24 mm 0p 0p FF	mm: Register No. (=00-7F) pp: Register Value (=00-7F) <i>See the "Register setting"</i>
CAM_ColorLevel	Reset	8x 01 04 09 00 FF	Color gain setting
	Up	8x 01 04 09 02 FF	
	Down	8x 01 04 09 03 FF	
CAM_ColorPhase	Reset	8x 01 04 0F 00 FF	Color hue setting
	Up	8x 01 04 0F 02 FF	
	Down	8x 01 04 0F 03 FF	
CAM_ColorGain	Direct	8x 01 04 49 00 00 00 0p FF	p: Color Gain setting 0h (60%) to Eh (200%)
CAM_ColorHue	Direct	8x 01 04 4F 00 00 00 0p FF	p: Color Hue setting 0h (- 14 dgree) to Eh (+14 degrees)
CAM_ColorSpeed	-	8x 01 04 56 0p FF	p :Color speed set value (0-7)
CAM_Stablizer	On	8x 01 04 34 02 FF	Digital Image Stabilizer
	Off	8x 01 04 34 03 FF	
CAM_Defog	On	8x 01 04 37 02 00 FF	Defog On/Off
	Off	8x 01 04 37 03 00 FF	
CAM_HLC	Parameter Set	8x 01 04 14 0p 0q FF	p:HLC Level (0:Off, 1:On) q:HLC mask level(0:Off, 1(low)-F(high)
CAM_SpotAE	On	8x 01 04 59 02 FF	Spot AE mode
	Off	8x 01 04 59 03 FF	

	Position	8x 01 04 29 0p 0q 0r 0s FF	pq:X(0-F), rs:Y(0-F)
CAM_Memory	Reset	8x 01 04 3F 00 0p FF	p:Memory Number(0-F)
	Set	8x 01 04 3F 01 0p FF	(See. Custom/Memory Preset Setting Items)
	Recall	8x 01 04 3F 02 0p FF	
CAM_Custom	Reset	8x 01 04 3F 00 7F FF	Starts up in this mode when the power is turned on
	Set	8x 01 04 3F 01 7F FF	(*The SET command must be sent one time to activate the custom preset.
	Recall	8x 01 04 3F 02 7F FF	(* Inactive : When the power is turned on, it starts up in the settings before the power is turned off.
	Inactive	8x 01 04 3F 10 7F FF	(See. Custom/Memory Preset Setting Items)
	Active	8x 01 04 3F 11 7F FF	
CAM_MinShutter	On	8x 01 04 12 02 FF	Minimum shutter enable
	Off	8x 01 04 12 03 FF	Minimum shutter disable
	Limit	8x 01 04 13 00 00 0p 0q FF	pq : minimum shutter position (05h~15h)

< Additional Command >

Command Set	Command	Command Packet	Comments
KT_KeyAct	Stop	8x 01 70 01 00 FF	
	Up	8x 01 70 01 21 FF	
	Down	8x 01 70 01 22 FF	
	Left	8x 01 70 01 23 FF	
	Right	8x 01 70 01 24 FF	
	Set	8x 01 70 01 26 FF	Enter Key
	Menu Off	8x 01 70 01 27 FF	Menu Off
	Factory Default	8x 01 70 01 0F FF	Initialize Camera Data
	Auto Zoom	8x 01 70 01 20 FF	Repeat TELE ~ WIDE. To stop, send the Auto Zoom command one more time
	Auto Zoom 1 time	8x 01 70 01 1F FF	
KT_DayNightMode	Auto	8x 01 70 04 00 FF	
	Day	8x 01 70 04 01 FF	
	Night	8x 01 70 04 02 FF	
	External-High	8x 01 70 04 03 FF	Night = Ext. input level is High
	External-Low	8x 01 70 04 04 FF	Night = Ext. input level is Low
KT_DayNightColor	-	8x 01 70 A2 0p FF	p : Night Color Mode (0:off ,1:on)
KT_CvbsNgtColorBurst	On	8x 01 70 13 02 FF	CVBS color burst night mode on
	Off	8x 01 70 13 03 FF	CVBS color burst night mode off
KT_AutoICRdelay	Delay Time	8x 01 04 41 01 00 0p 0q FF	pq: sec (0~60sec)
KT_ExtICRthreshold (Ext.H or Ext.L mode)	Day->Night(EXT-H)	8x 01 70 05 10 0p 0q FF	pq: ICR OFF→ON Threshold Level (Day->Night)
	Night->Day(EXT-H)	8x 01 70 05 11 0p 0q FF	pq: ICR ON→OFF Threshold Level (Night->Day)
	Day->Night(EXT-L)	8x 01 70 05 20 0p 0q FF	pq: ICR OFF→ON Threshold Level (Day->Night)
	Night->Day(EXT-L)	8x 01 70 05 21 0p 0q FF	pq: ICR ON→OFF Threshold Level (Night->Day)
KT_AgcAutoLimit	-	8x 01 70 34 pp FF	pp :AGC Max Limit (0x00~0xFF)
KT_Sharpness	-	8x 01 70 53 0p FF	p:sharpness level (0x00~0x0E)
KT_ZoomStartStop	-	8x 01 70 50 0p 0q 0q 0q 0q FF	p : 0(start) / 1(stop) qqqq: start position (0001~0021) / stop position (0001~018C) (*Stop position must be greater than start position
KT_ZoomDirect	-	8x 01 71 20 0p 0q 0r 0z FF	pqrz : Zoom Position (0000 ~ 26C0)
KT_ZoomFocusDirect	-	8x 01 71 20 0z 0z 0z 0z 0f 0f 0f 0f FF	zzzz : Zoom Position ffff : Focus Position
KT_FocusDirect	-	8x 01 71 21 0p 0q 0r 0z FF	pqrz : Focus Position (*This command will always move
KT_SetNearFarLimit	-	8x 01 71 24 0p FF	P : 0 (full) / 1 (limit)
KT_DispKtZoomRatio	-	8x 01 71 22 0p FF	p : 0 (normal type) / 1 (ktnic type)
KT_ZoomFocusPreset	Set	8x 01 70 3F 01 0p 0q 0r FF	pqr : preset Number (0x000~0x0FF)
	Recall	8x 01 70 3F 02 0p 0q 0r FF	pqr : preset Number (0x000~0x0FF)
	Clear	8x 01 70 3F 03 0p 0q 0r FF	pqr : preset Number (0x000~0x0FF)
	Clear All Preset	8x 01 70 3F 0F 00 00 00 FF	Clear all preset data
KT_ZmSpeed	Speed	8x 01 70 51 0p FF	p : Speed (0~7)
KT_AE_Brightness;	Level	8x 01 70 30 00 0p FF	p : AE Brightness Level (0x00~0x0E)
KT_MaxField	-	8x 01 70 31 00 0p FF	p : AE Sens up (0~5)
KT_SequentialShutter	-	8x 01 70 4E 0p FF	p : Sequential Shutter (2 :on, 3:off)
	Set	8x 01 70 4F 0p qq FF	p : Sequential Shutter set 1(Mode A) /2(Mode B) /3(Mode C) / 4(Mode D) q : AE Shutter(0x05~0x15)
KT_AE_ShutterLimit	On	8x 01 70 A3 01 FF	Minimum shutter enable
	Off	8x 01 70 A3 00 FF	Minimum shutter disable
	Minimum Limit	8x 01 70 A4 pq FF	pq : minimum shutter position (05h~15h)
	Maximum Limit	8x 01 70 A5 pq FF	pq : maximum shutter position (05h~15h)
KT_DirectShutter	On	8x 01 70 E3 01 FF	Direct shutter on
	Off	8x 01 70 E3 00 FF	Direct shutter off

	Set	8x 01 70 E4 0p 0q 0r 0s FF	pprs : Position
KT_WDRLevel	Level	8x 01 70 3A pp FF	pp : WDRLevel (0x00~0x1D)
KT_WDRAgcMax	-	8x 01 71 D5 pp FF	pp : WDR Agc Max (0x01~0x32)
KT_DefogOnLevel;	Level	8x 01 70 3C pp 00 FF	pp : DefogOnLevel(0x00~0x10)
KT_DefogAutoLevel	Level	8x 01 70 3D 0p 0q FF	p : DefogAutoLevel(0:high,1:mid,2:low) q : DefogThreshold(0x00~0x03)
KT_WdrBlcAeAuto	-	8x 01 70 46 0p FF	P : 0(all AE) 1(only auto)
KT_Dnr	Mode	8x 01 70 36 0p FF	p:0(off) 1(2D) 2(3D) 3(2D+3D)
	Level	8x 01 70 39 0p 0q FF	p:DNR level(0:auto,1:low,2:mid,3:high) q:DNR aperture(0~4)
KT_WbSpeed	-	8x 01 71 50 0p FF	p : Speed (0~7)
KT_WbBluseoffset	-	8x 01 71 51 pp FF	pp : Blue offset Value (0x00~0x64)
KT_WbRedoffset	-	8x 01 71 52 pp FF	pp : Red offset Value (0x00~0x64)
KT_WbSaturation	-	8x 01 71 53 pp FF	pp : Saturation value (0x00~0x14)
KT_WbHue	-	8x 01 71 54 pp FF	pp : Hue value (0x00~0x14)
KT_CcRedLine	-	8x 01 71 63 0p FF	p : Red Line Value (0~7)
KT_CcGreenLine	-	8x 01 71 64 0p FF	p : Green Line Value (0~7)
KT_CcBlueLine	-	8x 01 71 65 0p FF	p : Blue Line Value (0~7)
KT_CcArea	-	8x 01 71 66 0p qq rr FF	p : Color Area 0(magenta)/1(red)/2(yellow)/3(green)/4(cyan)/5(blue) qq : Color hue Value (0x00~0xB4) rr : Color gain Value (0x00~0x40)
KT_CcSave	-	8x 01 71 67 00 FF	Color adjust setting value save
KT_PipSet	-	8x 01 70 48 0p 0q 0s 0r FF	p=2 : PIP ON p=3 : PIP OFF p=F : Initialize PIP mode/size/position q=0~3 : pip window size 0(1/4),1(1/9),2(1/16),3(1/24) s=0~A : PIP window position – X r=0~A : PIP window position – Y
KT_Contrast	-	8x 01 71 40 pp FF	pp : Image contrast value(0x00~0x14)
KT_ImageRotate	-	8x 01 70 4A 0p 0q FF	p=corridor mode 0(Off) / 1(Full) / 2(Crop) q=mirror mode 0(Off) / 1(H-flip) / 2(V-flip) /3(HV-flip)
KT_PwrOnLensInitSkip	-	8x 01 70 49 0p FF	p : Focus reverse mode (2:on, 3:off)
KT_DwdrMode	Mode	8x 01 70 4B 0p FF	p : 0(off), 1(on), 2(auto)
	Level	8x 01 70 4C 0p FF	p : Dwdr on level(0x00~0x0f)
	Level	8x 01 70 4D 0p FF	p : Dwdr auto level (0~2)
KT_FactoryDefSystem	-	8x 01 70 EF EF FF	Initializes the entire system to the factory default. Be careful(!!!)
KT_FactoryDef	-	8x 01 70 EE EE FF	Factory default
KT_FocusRevVariable	On	8x 01 70 47 02 pp FF	pp : Rversestep(0x00~0x50)
	Off	8x 01 70 47 03 pp FF	
KT_Baudrate	-	8x 01 70 22 0p 0q FF	p : Baud channel (0:ch0, 1:ch1) q : Parity(0:none, 1:odd, 2:even)
KT_BootBaudrate	-	8x 01 70 BD 0p 0q 0r FF	p : Boot baudrate 0(default) / 1(2400) / 2(4800) / 3(9600) / 4(19200) / 5(38400) / 6(57600) / 7(115200) q : Boot parity 0(default) / 1(even) / 2(odd) r : 0(default) / 1(rs485)
KT_FosdDisp	Set	8x 01 70 0E pp qq FF	Set display type pp : 10 (Af Zoom Display) qq : 0(off) / 1(on) pp : 11 (Af Zoom Display PosX) qq : position X (0~18) pp : 12 (Af Zoom Display PosY) qq : position Y (0~18) pp : 20(Cam ID Display) qq : 0(off) / 1(on) pp : 21(Cam ID Display PosX) qq : position X (0~18) pp : 22(Cam ID Display PosY) qq : position Y (0~18)
KT_AfPresetAsManual	-	8x 01 70 95 0p FF	p : AF preset mode is like AF manual .0(off) / 1(on)
KT_AfSpeed	-	8x 01 70 94 0p FF	p : Af speed(0~7)

Inquiry Command List

Inquiry Command	Command Packet	Inquiry Packet	Comments
CAM_PowerInq	8x 09 04 00 FF	y0 50 02 FF	On
		y0 50 03 FF	Off (Standby)
CAM_ZoomPosInq	8x 09 04 47 FF	y0 50 0p 0q 0r 0s FF	pqrs: Zoom Position
CAM_DZoomModeInq	8x 09 04 06 FF	y0 50 02 FF	D-Zoom On
		y0 50 03 FF	D-Zoom Off
CAM_DZoomC/SModeInq	8x 09 04 36 FF	y0 50 00 FF	Combine Mode
		y0 50 01 FF	Separate Mode
CAM_DZoomPosInq	8x 09 04 46 FF	y0 50 00 00 0p 0q FF	pq: D-Zoom Position
CAM_FocusModeInq	8x 09 04 38 FF	y0 50 02 FF	Auto Focus
		y0 50 03 FF	Manual Focus
CAM_FocusPosInq	8x 09 04 48 FF	y0 50 0p 0q 0r 0s FF	pqrs: Focus Position
CAM_FocusNearLimitInq	8x 09 04 28 FF	y0 50 0p 0q 0r 0s FF	pqrs: Focus Near Limit Position
CAM_AFSensitivityInq	8x 09 04 58 FF	y0 50 02 FF	AF Sensitivity Normal
		y0 50 03 FF	AF Sensitivity Low
CAM_AFModeInq	8x 09 04 57 FF	y0 50 00 FF	Normal AF
		y0 50 01 FF	Interval AF
		y0 50 02 FF	Zoom Trigger AF
		y0 50 03 FF	Preset AF
CAM_AFTimeSettingInq	8x 09 04 27 FF	y0 50 0p 0q 0r 0s FF	pq: Movement Time, rs: Interval
CAM_IRCorrectionInq	8x 09 04 11 FF	y0 50 00 FF	Standard
		y0 50 01 FF	IR Light
CAM_WBModeInq	8x 09 04 35 FF	y0 50 00 FF	Auto
		y0 50 01 FF	In Door
		y0 50 02 FF	Out Door
		y0 50 03 FF	One Push WB
		y0 50 04 FF	ATW
		y0 50 05 FF	Manual
CAM_RGainInq	8x 09 04 43 FF	y0 50 00 00 0p 0q FF	pq: R Gain
CAM_BGainInq	8x 09 04 44 FF	y0 50 00 00 0p 0q FF	pq: B Gain
CAM_AEModeInq	8x 09 04 39 FF	y0 50 00 FF	Full Auto
		y0 50 03 FF	Manual
		y0 50 0A FF	Shutter Priority
		y0 50 0B FF	Iris Priority
		y0 50 0D FF	Bright
CAM_SlowShutterModeInq	8x 09 04 5A FF	y0 50 02 FF	Auto
		y0 50 03 FF	Manual
CAM_ShutterPosInq	8x 09 04 4A FF	y0 50 00 00 0p 0q FF	pq: Shutter Position
CAM_IrisPosInq	8x 09 04 4B FF	y0 50 00 00 0p 0q FF	pq: Iris Position
CAM_GainPosInq	8x 09 04 4C FF	y0 50 00 00 0p 0q FF	pq: Gain Position
CAM_GainLimitInq	8x 09 04 2C FF	y0 50 0q FF	p: Gain Limit
CAM_BrightPosInq	8x 09 04 4D FF	y0 50 00 00 0p 0q FF	pq: Bright Position
CAM_ExpCompModeInq	8x 09 04 3E FF	y0 50 02 FF	On
		y0 50 03 FF	Off
CAM_ExpCompPosInq	8x 09 04 4E FF	y0 50 00 00 0p 0q FF	pq: ExpComp Position
CAM_BackLightModeInq	8x 09 04 33 FF	y0 50 02 FF	On
		y0 50 03 FF	Off
CAM_AE_ResponseInq	8x 09 04 5D FF	y0 50 pp FF	pp: 01 to 30 (hex)
CAM_WDModeInq	8x 09 04 3D FF	y0 50 02 FF	On Wide-D
		y0 50 03 FF	Off
CAM_WDParameterInq	8x 09 04 2D FF	y0 50 00 00 00 0s 00 00 00 FF	s: Blown-out highlight correction level
CAM_ApertureInq	8x 09 04 42 FF	y0 50 00 00 0p 0q FF	pq: Aperture Gain
CAM_HRModeInq	8x 09 04 52 FF	y0 50 02 FF	On (Hi-Resolution)
		y0 50 03 FF	Off
CAM_NRModeInq	8x 09 04 53 FF	y0 50 0p FF	Noise Reduction p: 0 to 5
CAM_GammaInq	8x 09 04 5B FF	y0 50 0p FF	Gamma p: 0 to 8
CAM_HighSensitivityInq	8x 09 04 5E FF	y0 50 02 FF	On
		y0 50 03 FF	Off
CAM_LR_ReverseModeInq	8x 09 04 61 FF	y0 50 02 FF	On
		y0 50 03 FF	Off
CAM_FreezeModeInq	8x 09 04 62 FF	y0 50 02 FF	On
		y0 50 03 FF	Off

CAM_PictureEffectModeInq	8x 09 04 63 FF	y0 50 00 FF	Off
		y0 50 02 FF	Neg.Art
		y0 50 04 FF	B&W
		y0 50 1p FF	p=1~B : RED1~4/BLUE1~4/GREEN1~4
CAM_PictureFlipModeInq	8x 09 04 66 FF	y0 50 02 FF	On
		y0 50 03 FF	Off
CAM_ICRModeInq	8x 09 04 01 FF	y0 50 02 FF	On
		y0 50 03 FF	Off
CAM_AutoICRModeInq	8x 09 04 51 FF	y0 50 02 FF	On
		y0 50 03 FF	Off
CAM_AutoICRThresholdInq	8x 09 04 21 FF	y0 50 00 00 0p 0q FF	pq: ICR ON → OFF Threshold Level
CAM_AutoICRAAlarmReplyInq	8x 09 04 31 FF	y0 50 02 FF	On
		y0 50 03 FF	Off
CAM_MemSaveInq	8x 09 04 23 0X FF	y0 50 0p 0p 0q 0q FF	X: 00 to 07 (Address) ppqq: 0x0000 to 0xFFFF (Data)
CAM_DisplayModeInq	8x 09 04 15 FF (8x 09 06 06 FF)	y0 50 02 FF	On
		y0 50 03 FF	Off
CAM_MuteModeInq	8x 09 04 75 FF	y0 50 02 FF	On
		y0 50 03 FF	Off
CAM_PrivacyDisplayInq	8x 09 04 77 FF	y0 50 pp pp pp pp FF	pp pp pp pp: Mask Display (0: OFF, 1: ON)
CAM_PrivacyPanTiltInq	8x 09 04 79 FF	y0 50 0p 0p 0p 0q 0q 0q FF	ppp: Pan qq: Tilt
CAM_PrivacyPTZInq	8x 09 04 7B mm FF	y0 50 0p 0p 0p 0q 0q 0q 0r 0r 0r 0r FF	mm: Mask Settings ppp: Pan qqq: Tilt rrr: Zoom
CAM_PrivacyMonitorInq	8x 09 04 6F FF	y0 50 pp pp pp pp FF	pp pp pp pp: Mask is displayed now.
CAM_IDInq	8x 09 04 22 FF	y0 50 0p 0q 0r 0s FF	pqrs: Camera ID
CAM_VersionInq	8x 09 00 02 FF	y0 50 00 78	mnpq: Model Code (04xx)
		mn pq rs tu vw FF	rstu: ROM version vw: Socket Number (=02) See: "Cam_VersionInq"
CAM_MDModeInq	8x 09 04 1B FF	y0 50 02 FF	On
		y0 50 03 FF	Off
CAM_MDFunctionInq	8x 09 04 1C FF	y0 50 0m 0n 0p 0q 0r 0s FF	m: Display mode n: Detection Frame Set (0 to F) pq: Threshold Level (0 to FF) rs: Interval Time set (0 to FF)
CAM_MDWindowInq	8x 09 04 1D 0m FF	y0 50 0p 0q 0r 0s FF	m: Select Detection Frame (0, 1, 2, 3) p: Start Horizontal Position (00 to 0B) q: Start Vertical Position (00 to 07) r: Stop Horizontal Position (01 to 0C) s: Stop Vertical Position (01 to 08)
CAM_ContinuousZoomPos ReplyModeInq	8x 09 04 69 FF	y0 50 02 FF	On
		y0 50 03 FF	Off
CAM_ZoomPosReplyIntervalTi meInq	8x 09 04 6A FF	y0 50 00 00 0p 0p FF	pp: Interval Time
CAM_ContinuousFocusPos ReplyModeInq	8x 09 04 16 FF	y0 50 02 FF	On
		y0 50 03 FF	Off
CAM_FocusPosReplyIntervalTi meInq	8x 09 04 1A FF	y0 50 00 00 0p 0p FF	pp: Interval Time
CAM_ExAutoICRThresholdInq	8x 09 04 1F 21 00 FF	y0 50 00 00 0p 0q FF	pq : ICR ON→OFF threshold when Auto ICR is on (Night → Day)
CAM_ExAutoICRONLevelInq	8x 09 04 1F 21 01 FF	y0 50 00 00 0p 0q FF	pq : ICR OFF→ON threshold when Auto ICR is on (Day → Night)
CAM_RegisterValueInq	8x 09 04 24 mm FF	y0 50 0p 0p FF	mm: Register No. (00 to 7F) pp: Register Value (00 to FF)
CAM_ColorGainInq	8x 09 04 49 FF	y0 50 00 00 00 0p FF	p: Color Gain setting 0h (60%) to Eh (200%)
CAM_ColorHueInq	8x 09 04 4F FF	y0 50 00 00 00 0p FF	p: Color Hue setting 0h (- 14 degrees) to Eh (+ 14 degrees)
CAM_StabilizerInq	8x 09 04 34 FF	y0 50 02 FF	Stabilizer(DIS) on
		y0 50 03 FF	Stabilizer(DIS) off
CAM_DefogInq	8x 09 04 37 FF	y0 50 02 0p FF	Defog On
		y0 50 03 00 FF	Defog Off
CAM_HLCInq	8x 09 04 14 FF	y0 50 0p 0q FF	p:HLC Level (0:Off, 1:On) q:HLC mask level(0:Off, 1(low)~F(high)
CAM_SpotAEModeInq	8x 09 04 59 FF	y0 50 02 FF	Spot AE on
		y0 50 03 FF	Spot AE Off
CAM_SpotAEPosInq	8x 09 04 29 FF	y0 50 0p 0q 0r 0s FF	pq:X(0~F), rs:Y(0~F)

CAM_MemoryInq	8x 09 04 3F FF	y0 50 pp FF	pp : memory number recalled last
CAM_MinShutterInq	8x 09 04 12 FF	y0 50 0p FF	p : 2(on)/3(off)
	8x 09 04 13 FF	y0 50 00 00 0p 0q FF	pq: min. shutter position

< Additional Inquiry >

Inquiry Command	Command Packet	Inquiry Packet	Comments
KT_MenuOnOffInq	8x 09 70 01 FF	y0 50 02 FF	Menu on
		y0 50 03 FF	Menu off
KT_DayNightModeInq	8x 09 70 04 FF	y0 50 0p 0q FF	pq: day&night mode
KT_CvbsNgtColorBurstInq	8x 09 70 13 FF	y0 50 02 FF	Cvbs Ngt Color Burst on
		y0 50 03 FF	Cvbs Ngt Color Burst off
KT_ExtICRthresholdInq	8x 09 70 05 10 FF	y0 50 0p 0q FF	pq:ext-H day->night threshold
	8x 09 70 05 11 FF	y0 50 0p 0q FF	pq:ext-H night->day threshold
	8x 09 70 05 20 FF	y0 50 0p 0q FF	pq:ext-L day->night threshold
	8x 09 70 05 21 FF	y0 50 0p 0q FF	pq:ext-L night->day threshold
KT_PresetAFRangeInq	8x 09 70 03 FF	y0 50 0p 0q FF	pq: preset AF range
KT_AgcAutoLimitInq	8x 09 70 34 FF	y0 50 pp FF	pp:AGC Max Limit (See. GAIN LIMIT table)
KT_SharpnessInq	8x 09 70 53 FF	y0 50 0p FF	p:sharpness level (0x00-0x0F)
KT_ZoomFocusPresetInq	8x 09 703F 0n 0n 0n 0n FF	y0 50 0v 0z 0z 0z 0f 0f 0f 0f FF	nnn: preset number(0x000-0x0FF) v : 1(saved), 0(empty) zzzz : zoom position ffff : focus position
KT_ZmSpeedInq	8x 09 70 51 FF	y0 50 0p FF	p : Zoom speed (0-7)
KT_HomePowerOnInq	8x 09 70 24 FF	y0 50 0p FF	p:Home Position Mode, 2(ON)/3(OFF)
KT_AE_BrightnessInq	8x 09 70 30 FF	y0 50 00 0p FF	p : Brightness level (0x00-0x0E)
KT_MaxFieldInq	8x 09 70 31 FF	y0 50 0p FF	p : AE Sens up (0-5)
KT_SequentialShutterInq	8x 09 70 4E FF	y0 50 02 FF	Sequential Shutter on
		y0 50 03 FF	Sequential Shutter off
KT_AE_ShutterLimitInq	8x 09 70 A3 FF	y0 50 0r FF	r=0(off) / 1(on)
	8x 09 70 A4 FF	y0 50 pq FF	pq=min.shutter limit (5h-15h)
	8x 09 70 A5 FF	y0 50 pq FF	pq=max.shutter limit (5h-15h)
KT_DirectShutterInq	8x 09 70 E3 FF	y0 50 00 FF	Direct Shutter On
		y0 50 01 FF	Direct Shutter Off
KT_WDRLevelInq	8x 09 70 3A FF	y0 50 pp FF	p : WDR level (0x00-0x1D)
KT_DefogOnLevelInq	8x 09 70 3C FF	y0 50 pp FF	p : Defog level (0x00-0x10)
KT_DefogAutoLevelInq	8x 09 70 3D FF	y0 50 0p 0q FF	p : Auto level (0:high, 1:mid, 2:low) q : Threshold (0-3)
KT_WdrBlcAeAutoInq	8x 09 70 46 FF	y0 50 0p FF	p=0(all AE) / 1(only auto)
KT_DnrInq	8x 09 70 36 FF	y0 50 0p FF	p:0(off) 1(2D) 2(3D) 3(2D+3D)
	8x 09 70 39 FF	y0 50 0p 0q FF	p:DNR level(0:auto,1:low,2:mid,3:high) q:DNR aperture(0-4)
KT_WbSpeedInq	8x 09 71 50 FF	y0 50 pp FF	pp : Speed (0-7)
KT_WbBlueoffsetInq	8x 09 71 51 FF	y0 50 pp FF	pp : Blue offset (0x00-0x64)
KT_WbRedoffsetInq	8x 09 71 52 FF	y0 50 pp FF	pp : Red offset (0x00-0x64)
KT_WbSaturationInq	8x 09 71 53 FF	y0 50 pp FF	pp : Saturation value (0x00-0x14)
KT_WbHueInq	8x 09 71 54 FF	y0 50 pp FF	pp : Hue value (0x00-0x14)
KT_CcLineRedInq	8x 09 71 60 FF	y0 50 0p FF	p: Line Red (0-7)
KT_CcLineGreenInq	8x 09 71 61 FF	y0 50 0p FF	p : Line Green (0-7)
KT_CcLineBlueInq	8x 09 71 62 FF	y0 50 0p FF	p : Line Blue (0-7)
KT_CcAreaInq	8x 09 71 63 0p FF	y0 50 qq rr FF	p: Color Area 0(magenta)/1(red)/2(yellow)/3(green) 4(cyan)/5(blue) qq : Color Hue (0x00-0xB4) rr : Color Gain (0x00-0x40)
KT_PipSetInq	8x 09 70 48 FF	y0 50 0p 0q 0s 0r FF	p=2 : PIP ON p=3 : PIP OFF q=0-3 : pip window size 0(1/4),1(1/9),2(1/16),3(1/24) s=0-A : PIP window position - X r=0-A : PIP window position - Y
KT_ImageRotateInq	8x 09 70 4A FF	y0 50 0p 0q FF	p=corridor mode 0(Off) / 1(Full) / 2(Crop) q=mirror mode

			0(Off) / 1(H-flip) / 2(V-flip) / 3(HV-flip)
KT_PwrOnLensInitSkipInq	8x 09 70 49 FF	y0 50 0p FF	p : Focus reverse mode (2:on, 3:off)
KT_DwdrModeInq	8x 09 70 4B FF	y0 50 0p FF	p : 0(off), 1(on), 2(auto)
	8x 09 70 4C FF	y0 50 0p FF	p : Dwdr on level(0x00~0x0f)
	8x 09 70 4D FF	y0 50 0p FF	p : Dwdr auto level (0~2)
KT_FocusRevVariableInq	8x 09 70 47 FF	y0 50 02 pp FF	Focus Reverse mode On pp : Rvresetep(0x00~0x50)
		y0 50 03 pp FF	Focus Reverse mode Off pp : Rvresetep(0x00~0x50)
KT_BaudrateInq	8x 0 9 70 22 FF	y0 50 0p 0q FF	p : Baud channel (0:ch0, 1:ch1) q : Parity(0:none, 1:odd, 2:even)
KT_BootBaudrateInq	8x 09 70 BD FF	y0 50 0p 0q 0r 0s FF	p : BootLoader type q : Boot baudrate 0(default) / 1(2400) / 2(4800) / 3(9600) 4(19200) / 5(38400) / 6(57600) / 7(115200) r : Boot parity 0(default) / 1(even) / 2(odd) s : 0(default) / 1(rs485)
KT_FosdDispInq	8x 09 70 0E pp FF	y0 50 qq FF	pp : 10(AF Zoom Display) 11(AF Zoom Display PosX) 12(AF Zoom Display PosY) 20(Cam ID Display) 21(Cam ID Display posX) 22(Cam ID Display PosY) qq : 0(off) / 1(on) Position PosX,(0x00~0x12) Position PosY(0x01~0x13)
KT_AfPresetAsManualInq	8x 09 70 95 FF	y0 50 0p FF	p : AF preset Mode is like AF manual 0(off) / 1(on)
KT_AfSpeedInq	8x 09 70 94 FF	y0 50 0p FF	p: AF speed(0~7)

Lens Control System Inquiry CommandsCommand Packet 8x 097E 7E 00 FF

Byte	Bit	Comments
0	7	Destination Address
	6	
	5	
	4	
	3	Source Address
	2	
	1	
	0	
1	7	0 Completion Message
	6	1
	5	0
	4	1
	3	0
	2	0
	1	0
	0	0
2	7	0
	6	0
	5	0
	4	0
	3	Zoom Position (HH)
	2	
	1	
	0	
3	7	0
	6	0
	5	0
	4	0
	3	Zoom Position (HL)
	2	
	1	
	0	
4	7	0
	6	0
	5	0
	4	0
	3	Zoom Position (LH)
	2	
	1	
	0	
5	7	0
	6	0
	5	0
	4	0
	3	Zoom Position (LL)
	2	
	1	
	0	

Byte	Bit	Comments
6	7	0
	6	0
	5	0
	4	0
	3	Focus Near Limit (H)
	2	
	1	
	0	
7	7	0
	6	0
	5	0
	4	0
	3	Focus Near Limit (L)
	2	
	1	
	0	
8	7	0
	6	0
	5	0
	4	0
	3	Focus Position (HH)
	2	
	1	
	0	
9	7	0
	6	0
	5	0
	4	0
	3	Focus Position (HL)
	2	
	1	
	0	
10	7	0
	6	0
	5	0
	4	0
	3	Focus Position (LH)
	2	
	1	
	0	
11	7	0
	6	0
	5	0
	4	0
	3	Focus Position (LL)
	2	
	1	
	0	

Byte	Bit	Comment
12	7	0
	6	0
	5	0
	4	0
	3	0
	2	0
	1	0
	0	0
13	7	0
	6	0
	5	DZoomMode 0: Combine 1: Separate
	4	0: Normal 1: Interval
	3	2: Zoom Trigger
	2	AF Sensitivity 0: Slow 1: Normal
	1	Digital Zoom 1: On 0: Off
	0	Focus Mode 0: Manual 1: Auto
	7	0
	6	0
	5	0
	4	0
	3	Low Contrast Detection 1: Yes 0: No
14	2	Camera Memory Recall 1: Executing 0:
	1	Focus Command 1: Executing 0: Stopped
	0	Zoom Command 1: Executing 0: Stopped
	7	1 Terminator (FFh)
15	6	1
	5	1
	4	1
	3	1
	2	1
	1	1
	0	1

Camera Control System Inquiry Commands..... Command Packet 8x 097E 7E 01 FF

Byte	Bit	Comments
0	7	Destination Address
	6	
	5	
	4	
	3	Source Address
	2	
	1	
	0	
1	7	0 Completion Message
	6	1
	5	0
	4	1
	3	0
	2	0
	1	0
	0	0
2	7	0
	6	0
	5	0
	4	0
	3	R Gain (H)
2		
1		
0		
3	7	0
	6	0
	5	0
	4	0
	3	R Gain (L)
	2	
	1	
	0	
4	7	0
	6	0
	5	0
	4	0
	3	B Gain (H)
	2	
	1	
	0	
5	7	0
	6	0
	5	0
	4	0
	3	B Gain (L)
2		
1		
0		

Byte	Bit	Comments
6	7	0
	6	0
	5	0
	4	0
	3	WB Mode
	2	
1		
0		
7	7	0
	6	0
	5	0
	4	0
	3	Aperture Gain
	2	
	1	
	0	
8	7	0
	6	0
	5	0
	4	Exposure Mode
	3	
	2	
	1	
	0	
9	7	0
	6	0
	5	High-Resolution 1: On 0: Off
	4	Wide-D (1: Other than Off, 0: Off)
	3	0
	2	Back Light 1: On 0: Off
	1	Exposure Comp. 1: On 0: Off
	0	Slow Shutter 1: Auto 0:
10	7	0
	6	0
	5	0
	4	Shutter Position
	3	
	2	
	1	
	0	
11	7	0
	6	0
	5	0
	4	Iris Position
	3	
	2	
1		
0		

Byte	Bit	Comments
12	7	0
	6	0
	5	0
	4	0
	3	Gain Position
	2	
1		
0		
13	7	0
	6	0
	5	0
	4	Bright Position
	3	
	2	
	1	
	0	
14	7	0
	6	0
	5	0
	4	0
	3	Exposure Comp. Position
	2	
	1	
	0	
15	7	1 Terminator (FFh)
	6	1
	5	1
	4	1
	3	1
	2	1
	1	1
	0	1

Other Inquiry Commands Command Packet 8x 097E 7E 02 FF

Byte	Bit	Comments
0	7	Destination Address
	6	
	5	
	4	
	3	Source Address
	2	
	1	
	0	
1	7	0 Completion Message
	6	1
	5	0
	4	1
	3	0
	2	0
	1	0
	0	0
2	7	0
	6	0
	5	0
	4	0
	3	Auto ICR Alarm (1: On, 0:
	2	Auto ICR 1: On 0: Off
	1	0
0	Power 1: On 0: Off	
3	7	0
	6	0
	5	0
	4	ICR 1: On 0: Off
	3	Freeze 1: On 0: Off
	2	LR Reverse 1: On 0: Off
	1	0
0	0	
4	7	0
	6	0
	5	Privacy Zone 1: On 0: Off
	4	Mute 1: On 0: Off
	3	Title Display 1: On 0: Off
	2	Display 1: On 0: Off
	1	0
	0	0
5	7	0
	6	0
	5	0
	4	0
	3	Picture Effect Mode
	2	
1		
0		

Byte	Bit	Comments
6	7	0
	6	0
	5	0
	4	0
	3	0
	2	0
	1	0
	0	0
7	7	0
	6	0
	5	0
	4	0
	3	0
	2	0
	1	0
	0	0
8	7	0
	6	0
	5	0
	4	0
	3	Camera ID (HH)
	2	
	1	
0		
9	7	0
	6	0
	5	0
	4	0
	3	Camera ID (HL)
	2	
	1	
0		
10	7	0
	6	0
	5	0
	4	0
	3	Camera ID (LH)
	2	
	1	
0		
11	7	0
	6	0
	5	0
	4	0
	3	Camera ID (LL)
	2	
	1	
0		

Byte	Bit	Comments
12	7	0
	6	0
	5	0
	4	Memory 1: Provided 0: Not provided
	3	0
	2	ICR 1: Provided 0: Not provided
	1	Stabilizer 1:provided, 0: not provided
	0	1: 1/50, 1/25 0: 1/60, 1/30
13	7	0
	6	0
	5	0
	4	0
	3	Day&Night Mode 0:auto 1:day 2:night 3:Ext-H, 4:Ext-L
14	2	
	1	
	0	
	7	0
	6	0
	5	0
	4	0
15	3	0
	2	0
	1	0
	0	0
	7	1 Terminator (FFh)
	6	1
	5	1
4	1	
3	1	
2	1	
1	1	
0	1	

Enlargement Function1 Query Command..... Command Packet 8x 09 7E 7E 03 FF

Byte	Bit	Comments
0	7	Destination Address
	6	
	5	
	4	
	3	Source Address
	2	
	1	
0		
1	7	0 Completion Message
	6	1
	5	0
	4	1
	3	0
	2	0
	1	0
	0	0
2	7	0
	6	0
	5	0
	4	0
	3	Digital Zoom Position (H)
2		
3	7	0
	6	0
	5	0
	4	0
	3	Digital Zoom Position (L)
2		
4	7	0
	6	0
	5	0
	4	0
	3	AF Activation Time (H)
2		
5	7	0
	6	0
	5	0
	4	0
	3	AF Activation Time (L)
2		
6	7	0
	6	0
	5	0
	4	0
	3	AF Interval Time (H)
2		
7	7	0
	6	0
	5	0
	4	0
	3	AF Interval Time (L)
	2	
	1	
	0	
8	7	0
	6	0
	5	0
	4	0
	3	0
2		
9	7	0
	6	0
	5	0
	4	0
	3	0
2		
10	7	0
	6	0
	5	0
	4	0
	3	0
	2	MD (1: On, 0: Off)
	1	Reserved
	0	Picture flip (1: On, 0: Off)

Byte	Bit	Comments
6	7	0
	6	0
	5	0
	4	0
7	7	0
	6	0
	5	0
	4	0
8	7	0
	6	0
	5	0
	4	0
	3	0
2		
9	7	0
	6	0
	5	0
	4	0
	3	0
2		
10	7	0
	6	0
	5	0
	4	0
	3	0
	2	MD (1: On, 0: Off)
	1	Reserved
	0	Picture flip (1: On, 0: Off)

Byte	Bit	Comments
11	7	0
	6	Color Gain (0h (60%) to Eh (200%))
	5	
	4	
3	Advanced Privacy (1: Provided, 0: Not provided)	
2		
12	1	Alarm (1: Provided, 0: Not provided)
	0	Picture flip (1: Provided, 0: Not provided)
	7	0
13	6	0
	5	0
	4	0
	3	
	2	Gamma
1		
14	0	High Sensitivity mode (1: ON, 0: OFF)
	7	
	6	NR Level
	5	
15	4	0
	3	
	2	Gain Limit
	1	
	0	
15	7	1 Terminator (FFh)
	6	1
	5	1
	4	1
	3	1
	0	1

Enlargement Function2 Query Command..... Command Packet 8x 09 7E 7E 04 FF

Byte	Bit	Comm
0	7	Destination Address
	6	
	5	
	4	
	3	Source Address
	2	
	1	
0		
1	7	0 Completion Message
	6	1
	5	0
	4	1
	3	0
	2	0
	1	0
	0	0
2	7	0
	6	0
	5	0
	4	0
	3	0
	2	WideD mode (0: OFF, 1: ON)
	1	
0		
3	7	0
	6	0
	5	0
	4	0
	3	0
	2	
	1	0
	0	
4	7	0
	6	0
	5	0
	4	0
	3	0
	2	
	1	WideD blown-out highlight
	0	correction level 0: L 1: M 2: H
5	7	0
	6	0
	5	0
	4	0
	3	0
	2	
	1	
0		

Byte	Bit	Comments
6	7	0
	6	0
	5	0
	4	0
	3	0
	2	
	1	
0		
7	7	0
	6	0
	5	0
	4	0
	3	0
	2	0
	1	0
	0	Defog Mode(1:on,0:off)
8	7	0
	6	0
	5	0
	4	0
	3	0
	2	0
	1	0
	0	0
9	7	0
	6	0
	5	0
	4	0
	3	0
	2	0
	1	0
	0	0
10	7	0
	6	0
	5	0
	4	0
	3	0
	2	0
	1	0
	0	0

Byte	Bit	Comments
11	7	0
	6	0
	5	0
	4	0
	3	0
	2	0
	1	0
0	0	
12	7	0
	6	0
	5	0
	4	0
	3	0
	2	0
	1	0
	0	0
13	7	0
	6	0
	5	0
	4	0
	3	0
	2	0
	1	0
	0	0
14	7	0
	6	0
	5	0
	4	0
	3	0
	2	0
	1	0
	0	0
15	7	1 Terminator (FFh)
	6	1
	5	1
	4	1
	3	1
	2	1
	1	1
	0	1

Enlargement Function3 Query Command..... Command Packet 8x 09 7E 7E 05 FF

Byte	Bit	Comments
0	7	Destination Address
	6	
	5	
	4	
	3	Source Address
	2	
	1	
	0	
1	7	0 Completion Message
	6	1
	5	0
	4	1
	3	0
	2	0
	1	0
	0	0
2	7	0
	6	0
	5	0
	4	0
	3	0
3	7	0
	6	Reserved
	5	
	4	
	3	
	2	
	1	
	0	
4	7	0
	6	Reserved
	5	
	4	
	3	
	2	
	1	
	0	
5	7	0
	6	Reserved
	5	
	4	
	3	
	2	
6	7	0
	6	Reserved
	5	
	4	
	3	
	2	
7	7	0
	6	Reserved
	5	
	4	
	3	
	2	
8	7	0
	6	Reserved
	5	
	4	
	3	
	2	
9	7	0
	6	Reserved
	5	
	4	
	3	
	2	
10	7	0
	6	Reserved
	5	
	4	
	3	
	2	
11	7	0
	6	Reserved
	5	
	4	
	3	
	2	
12	7	0
	6	Reserved
	5	
	4	
	3	
	2	
13	7	0
	6	Reserved
	5	
	4	
	3	
	2	
14	7	0
	6	Reserved
	5	
	4	
	3	
	2	
15	7	1 Terminator (FFh)
	6	1
	5	1
	4	1
	3	1
	2	1
	1	1
	0	1

Byte	Bit	Comme
6	7	0
	6	Reserve
	5	
	4	
	3	
	2	
	1	
	0	
7	7	0
	6	Reserve
	5	
	4	
	3	
	2	
	1	
	0	
8	7	0
	6	Reserve
	5	
	4	
	3	
	2	
	1	
	0	
9	7	0
	6	Reserve
	5	
	4	
	3	
	2	
	1	
	0	
10	7	0
	6	Reserve
	5	
	4	
	3	
	2	
	1	
	0	

Byte	Bit	Comments
11	7	0
	6	Reserved
	5	
	4	
	3	
	2	
	1	
	0	
12	7	0
	6	Reserved
	5	
	4	
	3	
	2	
	1	
	0	
13	7	0
	6	Reserved
	5	
	4	
	3	
	2	
	1	
	0	
14	7	0
	6	Reserved
	5	
	4	
	3	
	2	
	1	
	0	
15	7	1 Terminator (FFh)
	6	1
	5	1
	4	1
	3	1
	2	1
	1	1
	0	1

Command Setting Values

SHUTTER SPEED

Index	60/30 mode	50/25 mode
15	1/10000	1/10000
14	1/6000	1/6000
13	1/4000	1/3500
12	1/3000	1/2500
11	1/2000	1/1750
10	1/1500	1/1250
0F	1/1000	1/1000
0E	1/725	1/600
0D	1/500	1/425
0C	1/350	1/300
0B	1/250	1/215
0A	1/180	1/150
09	1/125	1/120
08	1/100	1/100
07	1/90	1/75
06	1/60	1/50
05	1/30	1/25
04	1/15	1/12
03	1/8	1/6
02	1/4	1/3
01	1/2	1/2
00	1/1	1/1

IRIS

Index	Iris
11	F1.6
10	F2.0
0F	F2.4
0E	F2.8
0D	F3.4
0C	F4.0
0B	F4.8
0A	F5.6
09	F6.8
08	F8
07	F9.6
06	F11
05	F14
04	F16
03	F19
02	F22
01	F32
00	CLOSE

GAIN LIMIT & GAIN POSITION

Index	Gain
15	48dB
14	45dB
13	42dB
12	39dB
11	36dB
10	33dB
0F	30dB
0E	28dB
0D	26dB
0C	24dB
0B	22dB
0A	20dB
09	18dB
08	16dB
07	14dB
06	12dB
05	10dB
04	8dB
03	6dB
02	4dB
01	2dB
00	0dB

EXPOSURE COMPENSTAION(bright)

Index	Iris	Gain
0E	+7	+10.5 dB
0D	+6	+9 dB
0C	+5	+7.5 dB
0B	+4	+6 dB
0A	+3	+4.5 dB
09	+2	+3 dB
08	+1	+1.5 dB
07	0	0 dB
06	-1	-1.5 dB
05	-2	-3 dB
04	-3	-4.5 dB
03	-4	-6 dB
02	-5	-7.5 dB
01	-6	-9 dB
00	-7	-10.5 dB

Aperture (=sharpness)

Index	Level
0F	Sharp
...	
00	Dull

Red/Blue Manual Gain

0x00 ~ 0xFF

AE BRIGHT MODE LEVEL

Index	Iris	Gain
1F	F1.6	28 dB
1E	F1.6	26 dB
1D	F1.6	24 dB
1C	F1.6	22 dB
1B	F1.6	20 dB
1A	F1.6	18 dB
19	F1.6	16 dB
18	F1.6	14 dB
17	F1.6	12 dB
16	F1.6	10 dB
15	F1.6	8 dB
14	F1.6	6 dB
13	F1.6	4 dB
12	F1.6	2 dB
11	F1.6	0 dB
10	F2.0	0 dB
0F	F2.4	0 dB
0E	F2.8	0 dB
0D	F3.4	0 dB
0C	F4.0	0 dB
0B	F4.8	0 dB
0A	F5.6	0 dB
09	F6.8	0 dB
08	F8.0	0 dB
07	F9.6	0 dB
06	F11	0 dB
05	F14	0 dB
00	CLOSE	0 dB

IRIS CLOSE LIMIT

Index	Open Level
A0	More Open
...	
60	default
...	
10	More Close

Lens Control

Zoom Position	0000 ~ 4000 ~ 7AC0 Wide end Optical Digital Tele end Tele end		
Focus Position	1000 ~ F000 Far end Near end		
Focus Near Limit	<table border="1"> <tr> <td>1000 // inf 1100 //500m 1300 //200m 1500 //100m 2000 //60m 2500 // 30m 3000 // 10m 5000 // 5m 7000 // 3m 9000 // 2m A000 // 1.5m C000 // 1m D000 // 50cm F000 // 10cm</td> <td>The Lower 1 byte is fixed to 00 (*) As the distance on the left will differ due to temperature or any other conditions.</td> </tr> </table>	1000 // inf 1100 //500m 1300 //200m 1500 //100m 2000 //60m 2500 // 30m 3000 // 10m 5000 // 5m 7000 // 3m 9000 // 2m A000 // 1.5m C000 // 1m D000 // 50cm F000 // 10cm	The Lower 1 byte is fixed to 00 (*) As the distance on the left will differ due to temperature or any other conditions.
1000 // inf 1100 //500m 1300 //200m 1500 //100m 2000 //60m 2500 // 30m 3000 // 10m 5000 // 5m 7000 // 3m 9000 // 2m A000 // 1.5m C000 // 1m D000 // 50cm F000 // 10cm	The Lower 1 byte is fixed to 00 (*) As the distance on the left will differ due to temperature or any other conditions.		

Digital Zoom Position

Digital Zoom Ratio	Combine Mode	Separate Mode
X1	4000	00
X2	6000	80
X3	6A80	AA
X4	7000	C0
X5	7300	CC
X6	7540	D5
X7	76C0	DB
X8	7800	E0
X9	78C0	E3
X10	7980	E6
X11	7A00	E8
X12	7AC0	EB

Optical Zoom Position

Zoom Ratio	Optical Zoom Position
X1	0000
X2	14C6
X3	21A0
X4	2780
X5	2B8A
X6	2EA2
X7	3124
X8	3346
X9	352A
X10	36D8
X11	385B
X12	39B3
X13	3AE0
X14	3CB7
X15	3D66
X16	3DF6
X17	3E6D
X18	3ECD
X19	3F1C
X20	3F40
X21	3F5F
X22	3F7A
X23	3F96
X24	3FAE
X25	3FC0
X26	3FD1
X27	3FE3
X28	3FF4
X29	3FFF
X30	4000

GAMMA POSITION

Index	Gamma
0	0.40
1	0.45
2	0.50
3	0.55
4	0.60
5	0.70
6	0.80
7	0.90
8	1.00

Title Setting

Line number	00 to 13h			
H-position	00 to 28h			
Blink	00: Dose not blink			
	01: Blinks			
Color	00	White	05	Green
	01	Yellow	06	Blue
	02	White	07	Black
	03	Red	08	Orange
	04	White		

00	01	02	03	04	05	06	07
A	B	C	D	E	F	G	H
08	09	0a	0b	0c	0d	0e	0f
I	J	K	L	M	N	O	P
10	11	12	13	14	15	16	17
Q	R	S	T	U	V	W	X
18	19	1a	1b	1c	1d	1e	1f
Y	Z	&		?	!	1	2
20	21	22	23	24	25	26	27
3	4	5	6	7	8	9	0
28	29	2a	2b	2c	2d	2e	2f
À	È	Ì	Ò	Ù	Á	É	Í
30	31	32	33	34	35	36	37
Ó	Ú	Â	Ê	Ô	Æ		Ã
38	39	3a	3b	3c	3d	3e	3f
Ë	Ï	Ç	ß	Ä	Ï	Ö	Ü
40	41	42	43	44	45	46	47
Å	\$		¥		£	¢	ı
48	49	4a	4b	4c	4d	4e	4f
ø	“	:	’	.	,	/	-
50							
→							

Custom/Memory Preset Setting Items

Item	Custom Preset	Memory Preset
Zoom Position	O	O
Digital Zoom On/Off	O	O
Digital Zoom Position	O	X
Zoom Start Position	O	X
Zoom Stop Position	O	X
Zoom Speed	O	X
AF Home Position	O	X
AF Limited Range	O	X
Focus Position	O	O
Focus Mode	O	O
Near Limit Setting	O	X
AF Sensitivity	O	X
AF Mode	O	O
AF Run Time	O	X
AF Interval Time	O	X
WB Mode	O	O

WB Data(Rgain,Bgain)	O	O
COLOR Gain	O	X
AE Mode	O	O
AE Response	O	X
AE Slow Shutter	O	O
Shutter Position	O	O
Iris Position	O	O
Gain Position	O	O
Gain Limit	O	O
Bright Position	O	O
Exposure Compensation Mode	O	O
Exposure Compensation Amount	O	O
High Sens	O	X
Flickerless	O	X
Aperture Level	O	O
Gamma	O	X
High Resolution	O	X
LR Reverse	O	X
Picture Flip	O	X
Freeze	O	X
Picture Effect	O	X
D-WDR	O	X
Defog	O	O
Defog Level	O	X
3DNR Mode	O	O
3DNR Level	O	X
2DNR Mode	O	X
2DNR Weight	O	X
Digital Image Stabilizer On/Off	O	X
Digital Image Stabilizer Setting	O	X
BackLight On/Off	O	O
BLC Setting	O	X
WDR On/Off	O	O
HLC On/off	O	X
HLC Setting	O	X
ICR On/Off	O	O
Auto ICR On/Off	O	O
Auto ICR Threshlod Level	O	X
ICR Alarm Setting	O	X
Day&Night Dwell Time	O	X
Day->Night AGC level	O	X
Night->Day AGC level	O	X
Day->Night EXT-H level	O	X
Night -> Day EXT-H level	O	X
Day->Night EXT-L level	O	X
Night -> Day EXT-L level	O	X
Privacy Mask On/Off	O	X
Privacy Mask Display	O	X
Privacy Mask Setting	O	X
Motion On/Off	O	X
Motion Display	O	X
Motion Setting	O	X
Mute	O	X
Title Display On/Off	O	X
Title Setting	O	X
Display On/Off	O	X
ETC	X	X

Register Setting

CAM_RegisterValue	8x 01 04 24 mm 0p 0p FF	mm: Register No. (=00-7F) pp: Register Value (=00-7F)
-------------------	----------------------------	--

command	Register (mm)	Value (pp)	contents
VISCA Baud Rate	00	00 (Default)	9600 bps
		01	19200 bps
		02	38400 bps
		03	115200bps
		04	57600 bps
		05	2400 bps
		06	4800 bps
Monitoring Mode	72	01	1080i/60
		02	1080i/60
		04	1080i/50
		06	1080p/30
		07	1080p/30
		08	1080p/25
		09	720p/60
		0A	720p/60
		0C	720p/50
		0E	720p/30
		0F	720p/30
		11	720p/25
		13	1080p/60
		14	1080p/50
15	1080p/60		
LVDS mode	74	00 (Default)	Single output
		01	Dual output
Zoom Limit	50	00~FF (default:00)	Wide Limit
	51	00~FF (default:00)	Tele Limit
D-Zoom Max	52	00-FF (Default:EB)	Max. digital zoom ratio = $256 \div (256 - \text{Value})$
FocusOffset @DomeCover	55	00-FF (Default:00)	00: None FF: Max.
Sens-Up	59	01	OFF
		02	X2
		03	X4
		04	X8
		05	X16
		06	X32
Day&Night	5F	00	Day
		08	Auto
Language	60	00	00:English
CVBS scale	7C	00	4:3
		01	16:9

RS232 Parity Bit	91	00 01 02	None parity Odd parity Even parity
Sensor Scan Mode	92	00 01	Full Crop

PELCO-D protocol for RS-485/RS-232

Command	Output : PELCO-D	Description
Zoom Tele	FF 01 00 20 00 00 CS	
Zoom Wide	FF 01 00 40 00 00 CS	
Focus Near	FF 01 01 00 00 00 CS	
Focus Far	FF 01 00 80 00 00 CS	
Iris Open	FF 01 02 00 00 00 CS	Menu command
Iris Close	FF 01 04 00 00 00 CS	Menu command
Stop	FF 01 00 00 00 00 CS	
Menu	FF 01 40 00 00 00 CS	Menu on
Up	FF 01 00 08 00 00 CS	Key action Up
Down	FF 01 00 14 00 00 CS	Key action Down
Left	FF 01 00 04 00 00 CS	Key action Left
Right	FF 01 00 02 00 00 CS	Key action Right
Default	FF 01 00 29 00 00 CS	Key action Default
Cam on	FF 01 88 00 00 00 CS	
Cam off	FF 01 08 00 00 00 CS	
Clear Preset	FF 01 00 05 00 zz CS	zz : preset no (00-FF)
Flip(180 rotate)	FF 01 00 07 00 21 CS	
Menu or SET	FF 01 00 07 00 5F CS	Menu command
Menu or SET	FF 01 00 07 00 60 CS	Menu command
Menu or SET	FF 01 00 03 00 62 CS	Menu command
Zoom speed	FF 01 00 25 00 zz CS	zz = 00(speed 1)/ 01(speed 4)/ 02(speed 6)/ 03(speed 7)
AF Mode	FF 01 00 2B 00 zz CS	zz : set AF mode 00(auto)/ 01(1 push)/ 02(one shot)/ 03(manual)/04(preset)
BLC Mode	FF 01 00 31 00 zz CS	zz : set BLC mode 01(BLC on)/ 02(BLC off)/ 03(HLC on)
WB Mode	FF 01 00 33 00 zz CS	zz : set WB mode 02(manual)/ 03(atw)/ 04(push)/ 05(indoor)/ 06(outdoor)/others(auto)
Shutter	FF 01 00 37 00 zz CS	zz : shutter (see. shutter table)
Get Pan Position	FF 01 00 51 00 00 CS	Pan position transmit request
Get Tilt Position	FF 01 00 53 00 00 CS	Tilt position transmit request
Query Pan Position	FF 01 00 59 zz zz CS	Response to Pan position input on the host zzzz : position
Query Tilt Position	FF 01 00 5B zz zz CS	Response to Tilt position input on the host zzzz : position
KT_Reset	FF 01 70 00 00 00 CS	Set value reset
KT_ResetEep	FF 01 7E EE 00 00 CS	Reset all system EEPROM, Reset to FACTORY DEFAULT status