

DQ-F3042DM



Features

- ◆ 1/2.8 SONY STARTVIS 2.13Megapixel Progressive Scan CMOS
- ◆ 3G-SDI (1080@60p/50p, 1080@30p/25p, 720@60p/50p, 720p30/25)
- ◆ Waterproof(IP67)
- ◆ Real-timeWDR,2D/3D-DNR,ACE,HLM, Sens-up
- ◆ DIS, Quick Zoom
- ◆ Option:Cable OSD Key

Specification

Camera	Image Device	1/2.8" type SONY CMOS (IMX327LQR)	
	Scanning System	Progressive Scan	
	Total Pixels	1945(H)x1109(V) : 2.16Mega pixel	
	Effective Pixels	1945(H) x 1097(V) : 2.13Mega pixel	
	Lens fitted	Board, Pinhole	
	Min. Illumination	0.0073Lux@F2.5, 30IRE	
	Sync System	Internal	
	Electronic Shutter	60Hz : 1/30~1/30,000sec, 50Hz : 1/25~1/30,000sec	
Video	Output 1	3G-SDI/ HD-SDI(max. 1080@60p/50p), EX-SDI 3.0	
	Output 2	CVBS (NTSC, PAL)	
	Resolution& frame rate	1080@60i/50i, 1080@60p/50p, 1080@30p/25p, 720@60p/50p, 720@30p/25p	
	DSP	Eyenix EN781	
OSD (option)	On Screen Display	Built-in	
	Language	English, Chinese, Chinese(S), Japanese, Korean, Russian	
	LENS	DC/ MANUAL	
	EXPOSURE	BRIGHTNESS/AGC/SHUTTER MODE&SPEED/SENS-UP	
	WHITE BALANCE	AWB/ATW/ PUSH LOCK/ MANUAL	
	BACKLIGHT	OFF/ HLC/ BLC/ WDR, ROI	
	DNR	OFF/ LOW/ MIDDLE/ HIGH	
	DAY&NIGHT	AUTO/ COLOR/ B&W	
	IMAGE	SHARPNESS/ COLOR LEVEL/ MIRROR/ FLIP/ LENS SHADING/ GAMMA/ D-ZOOM/ ACE/ DEFOG	
	SPECIAL	PRIVACY/ MOTION/ DIS	
	SYSTEM	SDI OUT/ SDI FORMAT/ FREQ/ CVBS OUT/ LANGUAGE/ CAM TITLE	
	Others	Operating Temperature	14°F~122°F (-10°C~+50°C)
		Storage Temperature	-4°F~140°F (-20°C~+60°C)
Humidity		Less than 80%	
Power Consumption		DC12V(±10%), Max.150mA	
Options		Lens, Cable OSD function	

Dimension

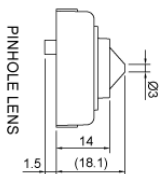
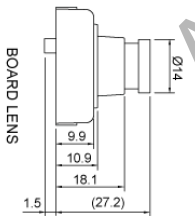
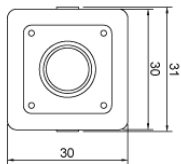

Option



OSD Cable

DQ-F3042DM

Interface

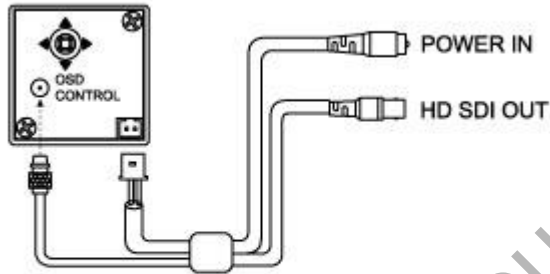

DIY CABLE CONNECTION

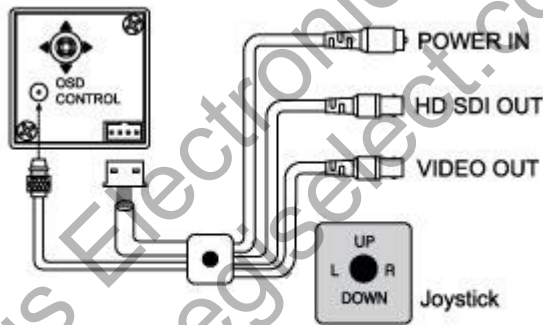

OSD CABLE CONNECTION

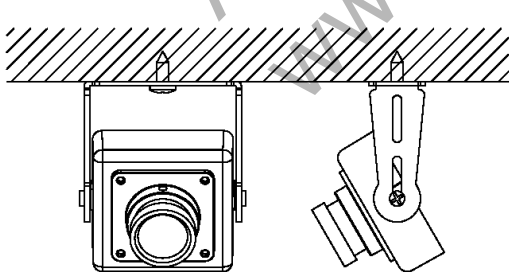

WALL MOUNTING BRACKET
Ø3 x 8L SCREW
M2 x 2.5L SCREW

CAMERA
LENS

