

LensConnect lens control support

USB3 Vision

Monochrome / Color CMOS Camera

STC-SBS500U3V-LCNT (5.0M / Monochrome / Low speed)

STC-SCS500U3V-LCNT (5.0M / Color / Low speed)

Product Specifications and User's Guide

Aegis Electronic Group
www.aegiselect.com

OMRON SENTECH CO., LTD.

Table of Contents

1	Product Precautions	9
2	Product conformity / compliance.....	9
3	Warranty	9
4	Overview.....	10
4.1	Features	10
4.2	Product Number Naming Method	10
5	Specifications	11
5.1	Electronic Specifications.....	11
5.2	Spectral Sensitivity Characteristics	13
5.2.1	STC-SBS500U3V-LCNT	13
5.2.2	STC-SCS500U3V-LCNT (without IR cut filter)	13
5.2.3	IR Cut Filter (STC-SCS500U3V-LCNT).....	14
5.3	Mechanical Specifications / Dimensions	15
5.4	Environmental Specifications	16
5.5	External Connector Specifications.....	17
5.5.1	USB 3.0 micro B	17
5.5.2	IO Connector.....	18
5.5.3	Reference Input Circuit	19
5.5.4	Reference Output Circuit	20
5.5.5	LensConnect Lens Connector.....	21
6	Sensor Information.....	22
6.1	Pixel Transferring Image.....	22
7	Image Acquisition and Camera Operational Modes (GenICam).....	23
7.1	Free run.....	23
7.2	Trigger Mode.....	24
7.2.1	Frame Start Trigger (Edge Preset)	25
7.2.2	Frame Start Trigger (Pulse Width Trigger).....	26

7.2.3	Exposure Start Trigger, Exposure End Trigger	27
7.2.4	Trigger Software	27
7.3	Burst Trigger.....	28
8	IO Function.....	29
8.1	Input Port Function	29
8.1.1	Trigger Input.....	29
8.1.2	LineStatus	29
8.1.3	Line Debouncer.....	30
8.1.4	Trigger Delay	30
8.2	Output Port Function	31
8.2.1	LineSource	31
8.2.2	User Output	33
8.2.3	Line Status	33
8.2.4	Output signal duration setting and Pulse width setting	33
8.3	Hardware Reset	33
9	Camera Functions	34
9.1	ROI (Region of Interest)	34
9.1.1	ROI (One Region).....	34
9.2	Pixel Format.....	36
9.3	Decimation.....	36
9.4	Image Flip	37
9.5	Gain	39
9.5.1	Analog Gain.....	39
9.5.2	Digital Gain.....	39
9.5.3	White Balance Gain (Only available for the color model)	40
9.6	Black Level	40
9.7	ALC (Auto Light Control).....	40
9.7.1	ALC Control Method.....	40
9.7.2	AGC (Auto Gain Control)	41
9.7.3	Auto Exposure	41
9.7.4	The setting procedure of ALC	41
9.8	White Balance (Only available for the color model).....	42
9.8.1	White balance control methods	42
9.8.2	Disable	42
9.8.3	Manual (Off).....	42

9.8.4	Auto White Balance (Continuous).....	42
9.8.5	Push to Set White Balance (Once).....	43
9.9	Gamma Table.....	44
9.10	Save and load the camera settings.....	45
9.10.1	Saving the Camera Settings.....	45
9.10.2	Loading Camera Settings.....	46
9.10.3	Loading Camera Settings when the Camera Power is on.....	46
9.10.4	Camera Settings Initialization.....	46
9.11	Pixel Defect Correction.....	47
9.12	Trigger.....	47
9.12.1	Trigger Signal Process.....	47
9.13	Device User ID.....	48
9.14	Event Control (Only available with USB3 Vision protocol).....	48
9.14.1	The way to use Event.....	48
9.14.2	Event Function.....	48
9.15	Chunk Control.....	49
9.15.1	The way to use Chunk.....	49
9.15.2	Chunk Data.....	49
9.16	Device Sleep Mode.....	50
9.17	LensConnect Control.....	51
9.17.1	Zoom Function.....	51
9.17.2	Focus Function.....	51
9.17.3	Iris Function.....	52
9.17.4	OpticalFilter Function.....	52
9.18	GenlCam command list.....	53
9.18.1	DeviceControl.....	53
9.18.2	ImageFormatControl.....	55
9.18.3	AcquisitionControl.....	56
9.18.4	TransportLayerControl.....	56
9.18.5	DigitalIOControl.....	57
9.18.6	CounterAndTimerControl.....	57
9.18.7	EventControl.....	57
9.18.8	EventExposureEndData.....	58
9.18.9	EventExposureStartData.....	58
9.18.10	EventTestData.....	58
9.18.11	AnalogControl.....	58
9.18.12	LUTControl.....	59
9.18.13	UserSetControl.....	59
9.18.14	ChunkDataControl.....	59
9.18.15	TestControl.....	59
9.18.16	LensConnect Control.....	60

10	Revision History	61
----	------------------------	----

Aegis Electronic Group
www.aegiselect.com

Precautions for safety

Please read carefully this "Precautions for safety" before use the camera. Then the camera uses correctly with agreeing with below notes.

In this "Precautions for safety", notes divides into "Warning" and "Caution" to use the camera safety and prevent to harm and damage.

	Warning	This shows, assumption for possibility of serious accident leading death or serious injury if ignore this note and camera uses incorrectly.
	Caution	This shows, assumption for possibility of bear the damage or physical damage if ignore this note and camera uses incorrectly.

About Graphic symbols



This symbol shows general prohibition.







This symbol shows completion or instruction.

[Environment / condition]









Warning	
	Do not use flammable or explosiveness atmospheres. This will cause of personal injury or fire.
	Do not use for "safety for human body" related usage. This camera is designed for use "do not harm human body immediately" if by any chance the camera has malfunction.
Caution	
	Use and store under specified environmental conditions (Vibration, shock, temperature, humidity) in the specifications for this camera. This will cause of fire or damage the camera.

[Installation and cable wiring]



Warning	
	Do not use with out of power voltage range that is specified in the specifications for this camera. This will cause of fire, electrification or malfunction.
	Do not wrong wiring. This will cause of fire or malfunction.

 Caution	
 Do not grounding DC power (+) of all devices that are connect to the camera. The camera housing is connecting to 0 V line of camera inside circuit. There is a risk of short circuit between camera inside ciurcuit and frame ground. This will cause of malfunction.	 It is necessary to wiring and mounting that is specified in the specifications for this camera. This will cause of fire or malfunction.
 It is necessary to wiring with turn off the camera. This will cause of electrification or malfunction.	 It is necessary to mounting the camera without stress for the cable. This will case of electrification or fire.



[Usage instruction]

 Warning	
 Do not touch the terminal and PCB board While turn on the camera. This will cause of electrification or accident caused by malfunction.	 Do not put combustibles near the camera. This will cause of fire.
 Do not use without usage that is specified in the specifications for this camera. This will cause of personal injury or malfunction.	 Do not push metals including screw driver into radiation holes. This will cause of electrification or malfunction.
 Do not touch the camera housing while or afterusing the camera. There is a risk of get burned.	
 Caution	
 Do not push contamination into opening of the camera. This will cause of electrification or malfunction.	 Do not block the radiation holes. This will cause of fire due to increase the camera inside temperature.



[Maintenance]

 Caution	
 Do not disassemble or repair the camera. This will cause of fire, electrification or malfunction.	 It is turn off the camera when maintaining or inspecting the camera. This will cause of electrification.

[Disposal]

 Caution	
 It is necessary to dispose as industrial waste. In EU, it is necessary to dispose of accordance with WEEE directive. 	

[Security Measures, Anti-virus protection]

 Warning	
 Install the latest commercial-quality antivirus software on the computer connected to the control system and maintain to keep the software up-to-date.	

Aegis Electronic Group
www.aegiselect.com

1 Product Precautions

- Do not give shock to the camera.
- Do not haul or damage the camera cable.
- Do not wrap the camera with any material while using the camera. This will cause the internal camera temperature to increase.
- When the camera moving or using the place that temperature difference is extreme, countermeasure for dew condensation (heat removal / cold removal) is necessary.
- While the camera is not using, keep the lens cap on the camera to prevent dust or contamination from getting in the sensor or filter and scratching or damaging it.

Do not keep the camera under the following conditions.

- In wet, moist, high humidity or dusty place
- Under direct sunlight
- In extreme high or low temperature place
- Near an object that releases a strong magnetic or electric field
- Place with strong vibrations
- Apply the power that satisfies the specified in specifications for the camera.
- The defective pixels may appear due to the sensor characteristics.
- Use below recommend materials (or equivalent materials) to clean the surface of glass.
 - Air dust: Non Freon air duster (NAKABAYASHI Co., LTD.)
 - Alcohol: Propan-2-ol (SAN'EI KAKO Co., LTD.)
 - Non-woven: nikowipe clean room (NKB)
- Use a soft cloth to clean the camera.

2 Product conformity / compliance

Please confirm regulation in each country by responsibility of exporter and importer when exporting this product from Japan.

3 Warranty

■ Warranty period

One year after delivery (However, the camera had malfunction with camera uses correctly)

In below case for a fee even within warranty period.

- The malfunction caused by incorrect usage, incorrect modify or repair.
- The malfunction caused by external shock including the camera dropping after delivery the camera.
- The malfunction caused by fire, earthquake, flood disaster, thunderbolt struck, other natural disaster or wrong voltage.

■ Warranty coverage

Exchange or repair the malfunction camera if the malfunction is occurred by our responsibility.

“Warranty” mean is warranty for the delivered camera itself. Please accept the induction damage by the camera malfunction is not included.

4 Overview

This document describes the specification of the following cameras.

STC-SBS500U3V-LCNT / STC-SCS500U3V-LCNT

4.1 Features

- USB3 Vision
- Maximum frame rate (Full resolution): 35.8 fps @ 5.0M 8bits
- CMOS (Global Shutter)
- Up to 1,080 Pixel Defect Correction
- 8bits, 10bits, 12bits output
- Supports lens control for LensConnected lens from CBC

4.2 Product Number Naming Method

STC-SBS500U3V-LCNT

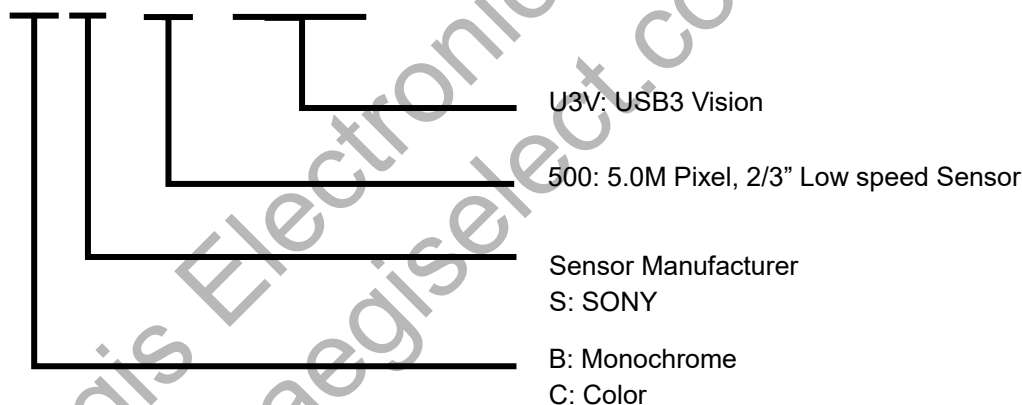

5 Specifications

5.1 Electronic Specifications

Model Number		STC-SBS500U3V-LCNT	STC-SCS500U3V-LCNT
Image Sensor		2/3" 5.0M Progressive Monochrome CMOS (SONY: IMX264)	2/3" 5.0M Progressive Color CMOS (SONY: IMX264)
Shutter Type		Global shutter	
Cell Size		3.45 (H) x 3.45 (V) μm	
Sync System		External trigger (Hardware, Software) / Free run	
Active Picture Elements (Output image)		2,448 (H) x 2,048 (V)	
Maximum Frame Rate (Full Scan)	8bits output	35.8 fps	
	10bits output		
	10bits Packed output		
	12bits output		
	12bits Packed output		
ADC bit width		10bits / 12bits	
Image Format		8bits / 10bits / 12bits output (Support packed on 10bits / 12bits)	
Noise Level	8bits output	Less than 3 digits (Gain 0 dB)	
	10bits / 10bits Packed output	Less than 12 digits (Gain 0 dB)	
	12bits / 12bits Packed output	Less than 48 digits (Gain 0 dB)	
Sensitivity (*1)		380 Lux	1,030 Lux
Exposure time	8bits output	1 μsecond to 16.777 seconds (Default: 27,485.8 $\mu\text{seconds}$)	
	10bits output		
	10bits Packed output		
	12bits output		
	12bits Packed output		
Gain	Analog Gain	0 to 43.2 dB (Default: 0 dB)	
	Digital Gain	x1 to x2 (Default: x1)	
Black Level	8bits output	0 to 31 digits	
	10bits / 10bits Packed output	0 to 127 digits	
	12bits / 12bits Packed output	0 to 511 digits	
White Balance Gain		N/A	0 (Black level) to x3.99 (Default: x1)
ROI		Horizontal: 64 to 2,448 (2,432 on Packed) pixels / Vertical: 32 to 2,048 lines (Default: 2,448 x 2,048) Adjustable Steps for image size: 16 pixels in horizontal direction (64 pixels on Packed) / 4 lines in vertical direction Adjustable Steps for offset: 4 pixels in horizontal direction / 4 lines in vertical direction	
Multi ROIs		N/A (1 region)	
Gamma		0.1 to 4.0 (Default = 1.0)	
Binning		N/A	
Decimation		x2 horizontal and vertical individually / Off	
Image Flip		Vertical flip / Horizontal flip / Horizontal and vertical flip / Off	
Defective Pixel Correction		Up to 1,080 points	

Default: **Bold**

Model Number		STC-MBS500U3V	STC-MCS500U3V
Auto Image Control	Auto Exposure	Support	
	Auto Gain	Support	
	Auto White Balance	N/A	Support
Operational Mode		Edge preset Trigger / Pulse width Trigger / Start Stop Trigger / Free run	
User Setting Storage		Support	
Communication		Through USB3.0 bus	
Interface		USB3.0 Super speed (USB3.0 micro B)	
Protocol		USB3 Vision 1.0.1, GenICam Standard Version (SFNC 2.2, PFNC 2.0) compliant	
Input / Output		Three GPIOs, One Camera Hardware Reset	
Power	Input Voltage	+5 V (typ.) (This conforms to USB standard) +8.0 to +24 V External power (via 6 pin connector) * Recommend with external power (*4)	
	Consumption (*3)	With lens	Maximum: 7.1W, Typical: 6.0 W Sleep Mode: 5 W
		Without lens	Maximum: 4.6W, Typical: 3.5 W Sleep Mode: 2.5 W

Default: **Bold**

Precautions

(*1) The sensitivity is measuring the luminance when white level achieved 100 % in below conditions.

Camera Setting		Environment	
Parameter	Setting	Parameter	Setting
Gain Up	0 dB	Light Source	Light Box (White)
AGC	Off	Color temperature	5,100K
White Balance	Optimum	Lens	
Electrical Shutter	1/30 seconds	F on Lens	F5.6
Black Level	Optimum	Target Luminance	IM-600 (Topcon)
Gamma	Factory Setting		

(*2) The camera operates as USB3.0 standard even camera connecting to a USB 2.0 port. Please careful about power consumption of camera when camera connecting to USB2.0 port.

(*3) Please use the external power supply. The power from USB Bus in some PC could be not enough to operate camera due to PC configuration or performance.

The power consumption is different depending on connecting type of LensConnect lens.

5.2 Spectral Sensitivity Characteristics

5.2.1 STC-SBS500U3V-LCNT

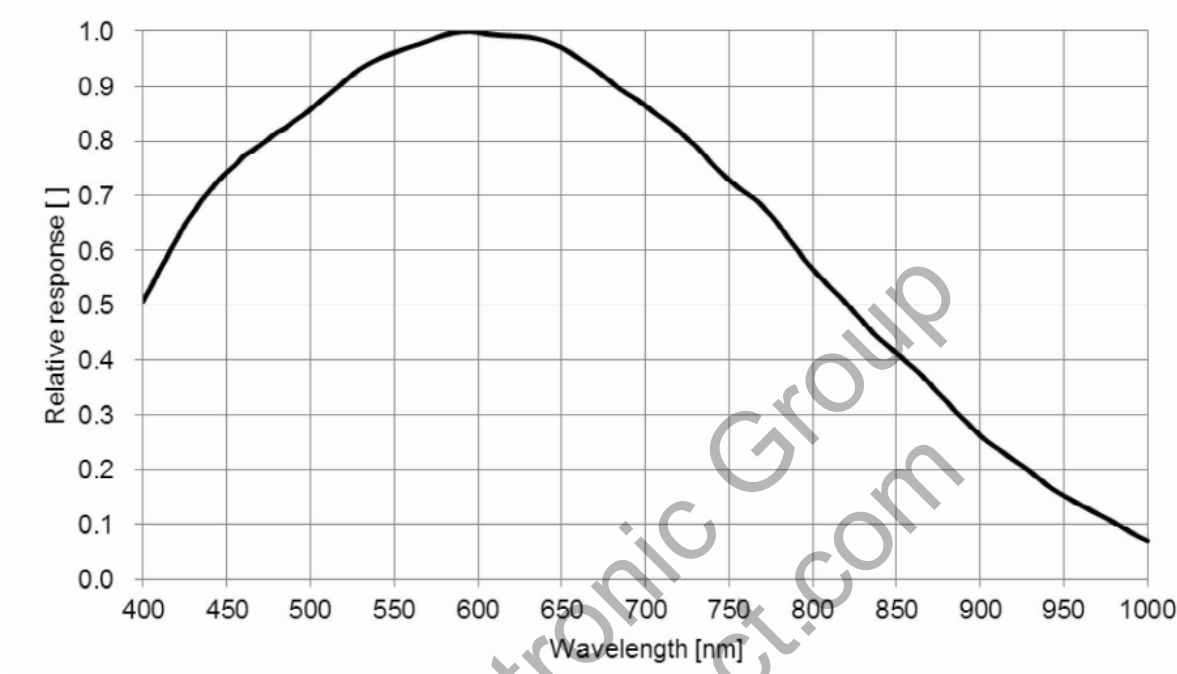

5.2.2 STC-SCS500U3V-LCNT (without IR cut filter)

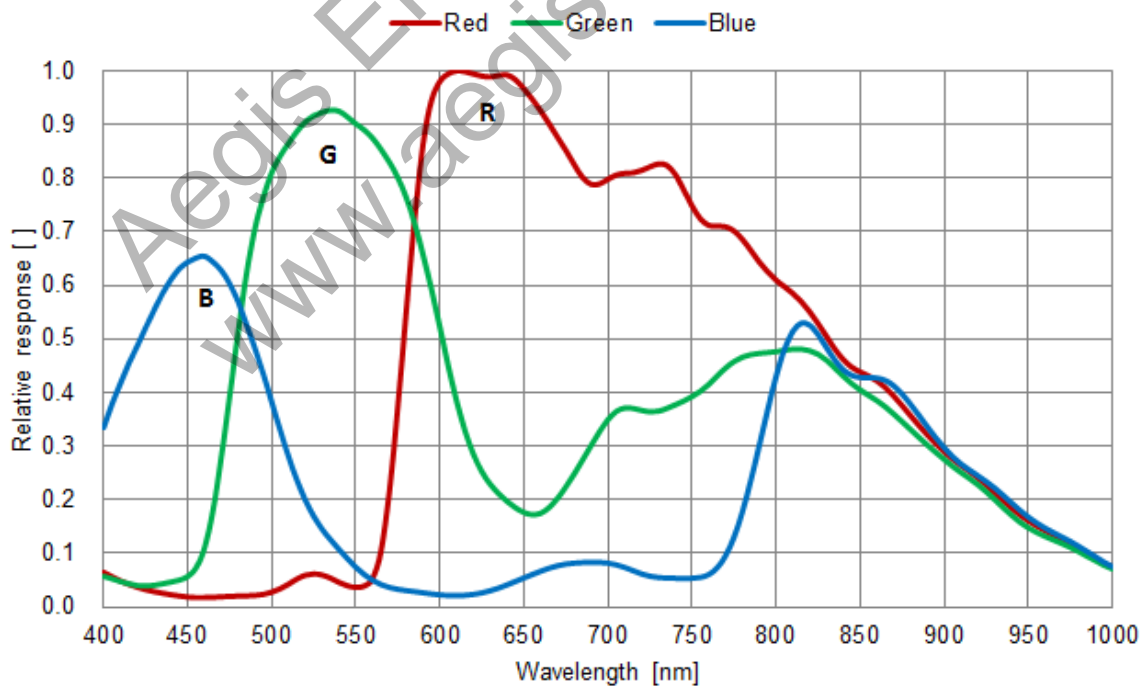

5.2.3 IR Cut Filter (STC-SCS500U3V-LCNT)

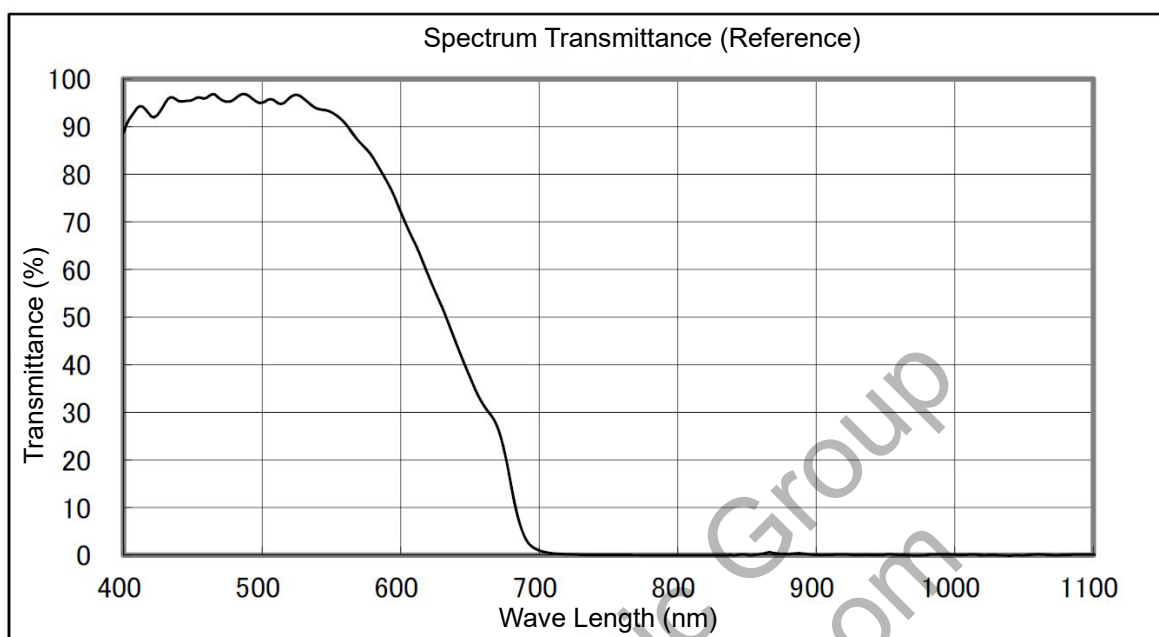

5.3 Mechanical Specifications / Dimensions

Model Number	STC-SBS500U3V-LCNT	STC-SCS500U3V-LCNT
Dimensions	28 (W) x 28 (H) x 40 (D) mm (*1)	
Optical Filter	No optical filter	IR cut filter
Optical Center Accuracy	Positional accuracy in Horizontal and Vertical directions: +/- 0.3 mm Rotational accuracy of Horizontal and Vertical: +/- 1.5 deg.	
Material	Aluminum alloy	
Lens Mount (*2)	C Mount	
Interface Connectors	USB Connector: USB3.0 micro B x 1 Power/IO Connector: HR10A-7R-6PB (Hirose) or equivalent x 1 LensConnect Lens Connector: HR10A-7R-6S (Hirose) or equivalent x 1	
Camera Mounting	1/4" Tripod screw holes (One on top and bottom plate) M4 screws holes (Four on top, bottom and both side plate)	
Weight	Approximately 80 g	

(*1) Excluding connectors

(*2) Recommend lens: More than F2.8 (Close side)

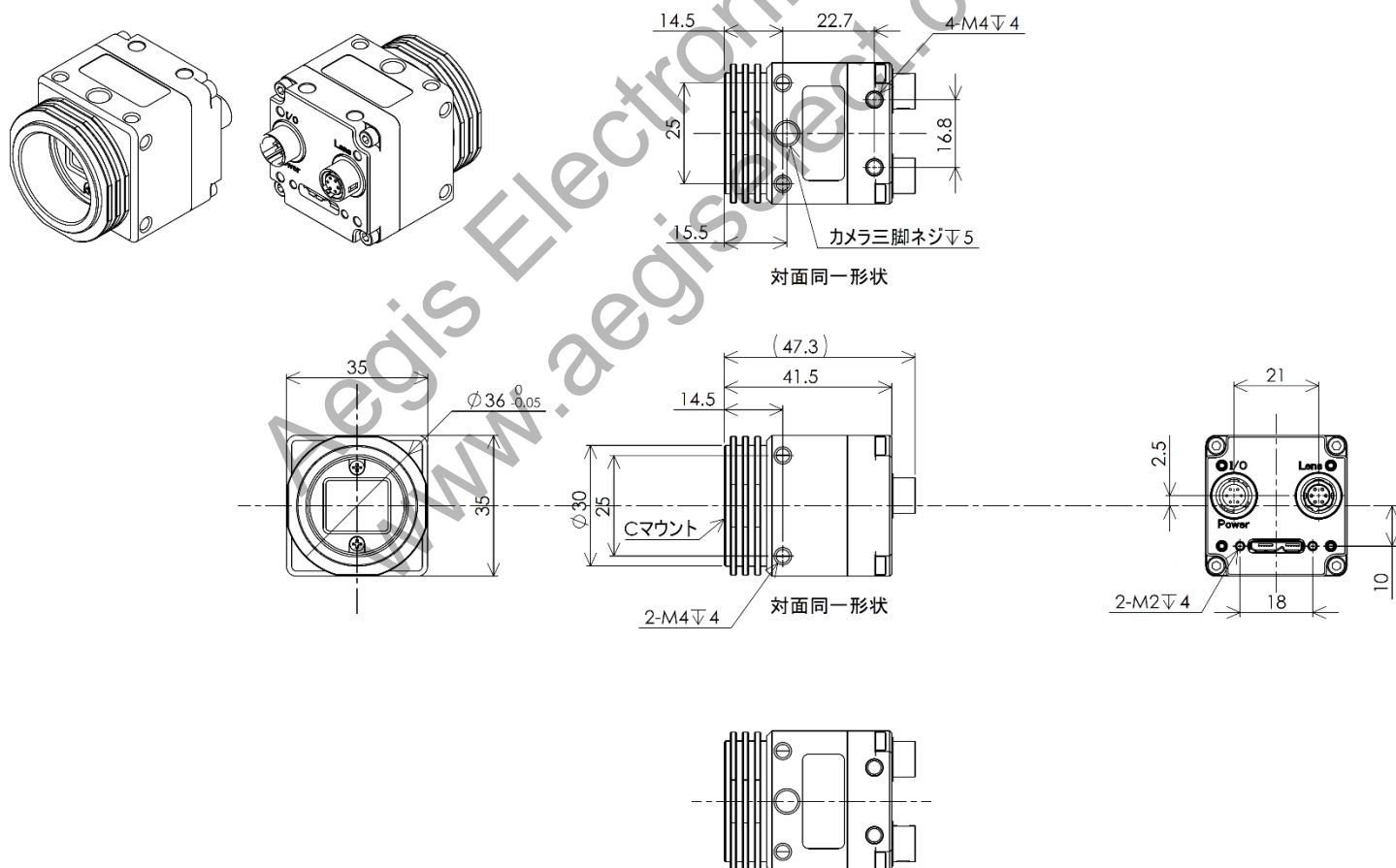

Unit: mm

5.4 Environmental Specifications

Model Number		STC-SBS500U3V-LCNT	STC-SCS500U3V-LCNT
Operational Temperature / Humidity	Minimum	Environmental Temperature: 0 deg. C Environmental Humidity: 20 to 85 %RH (No condensation)	
	Maximum	Camera housing temperature (top plate) shall not exceed +63 deg. C (*1) Environmental Humidity: 20 to 85 %RH (No condensation)	
Storage Temperature / Humidity		Environmental Temperature: -30 to +70 deg. C Environmental Humidity: 20 to 85 %RH (No condensation)	
Vibration		20 Hz to 200 Hz to 20 Hz (5 min. / cycle), acceleration 10 G, XYZ 3 directions 30 min. each	
Shock		Acceleration 38 G, half amplitude 6 ms, XYZ 3 directions 3 times each	
Standard Compliancy		EMS: EN61000-6-2, EMI: EN55011	
RoHS		RoHS Compliant	

(*1) Please ensure the camera is installed with appropriate heat dissipation. If camera has a mounted lens and a tripod with an aluminum plate, this could decrease camera housing temperature for heat dissipation. When the internal temperature sensor on camera shows less than +71 deg. C, camera housing temperature (top plate) will be less than +63 deg. C.

Taking these steps will maintain heat rating of electronic components of camera.

Upper side of camera

Measuring point

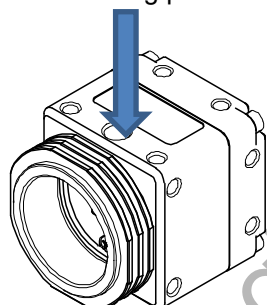

5.5 External Connector Specifications

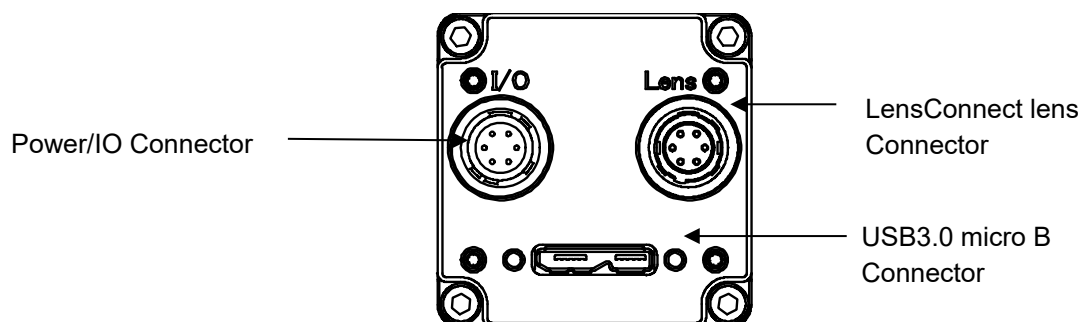

5.5.1 USB 3.0 micro B

This connector is compatible with a USB 3.0 micro B connector.
Connector size includes screw lock size and complies with USB3 Vision 1.0.1.

Pin assignment

Pin No.	Signal Name	Description
1	VBUS	Power
2	D-	USB 2.0 differential pair (D-)
3	D+	USB 2.0 differential pair (D+)
4	USB OTG	USB OTG ID
5	GND	GND
6	SSTX-	SuperSpeed transmitter differential pair (-)
7	SSTX+	SuperSpeed transmitter differential pair (+)
8	GND	GND
9	SSRX-	SuperSpeed receiver differential pair (-)
10	SSRX+	SuperSpeed receiver differential pair (+)



5.5.2 IO Connector

HR10A-7R-6PB (Hirose) or equivalent.

This connector is for external power supply and, input and output signals.

The trigger input and sync input/output signals can be assigned through camera setting communication.

As for the cable part (Female connector), HR10A-7P-6S (Hirose) or equivalent can be used.

Pin assignment

Pin No.	Signal Name	IN/OUT
1	GPIO_GND	-
2	GPIO2	IN/OUT
3	GPIO1	IN/OUT
4	GPIO0	IN/OUT
5	CAM_RESET	IN
6	CAM_PWR	-

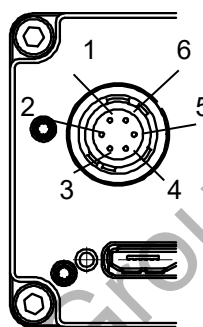

* Possible Maximum Rated Voltage is +24 V on CAM_RESET, GPIO0, GPIO1 and GPIO2.

* The camera operates with external power when USB Bus power and external power supply to camera at same time.

* When the camera power is switching (from USB BUS power to external power, from external power to USB BUS power), camera resets.

Input Output DC characteristics

Pin No.	Signal Name	Function	IN/OUT	Voltage		Current	
				Low Voltage	High Voltage		
1	IO_GND	GND	-			-	
2	GPIO2	General Purpose Input Output	IN/OUT	IN	Less than +1.00 V	+3.00 to +24 V	4 μ A (typ.) (*4)
				OUT	0 to +2.20 V (*1)	+3.00 to +24 V (*2)	15 mA (Max.) (*3)
3	GPIO1	General Purpose Input Output	IN/OUT	IN	Less than +1.00 V	+3.00 to +24 V	4 μ A (typ.) (*4)
				OUT	0 to +2.20 V (*1)	+3.00 to +24 V (*2)	15 mA (Max.) (*3)
4	GPIO0	General Purpose Input Output	IN/OUT	IN	Less than +1.00 V	+3.00 to +24 V	4 μ A (typ.) (*4)
				OUT	0 to +2.20 V (*1)	+3.00 to +24 V (*2)	15 mA (Max.) (*3)
5	CAM_RESET	Camera Hardware Reset	IN	IN	Less than +0.80 V	+3.00 to +24 V	4 μ A (typ.) (*4)
6	CAM_PWR	Camera power	-		+8 to +24 V	-	

(*1): If the current on IO port is at 15mA when using low voltage output, output voltage could increase for internal register.

(*2): This is the maximum charging voltage when external IO port is connected.

(*3): When the external IO port is connected, control current less than 15 mA on IO port.

(*4): This value is the typical current value of Input Port when High Voltage is input.

Default Setting of Input / Output

Pin No.	Signal Name	Default	
		IN/OUT	Setting
2	GPIO2	IN	Disable
3	GPIO1	IN	Disable
4	GPIO0	IN	Disable

5.5.3 Reference Input Circuit

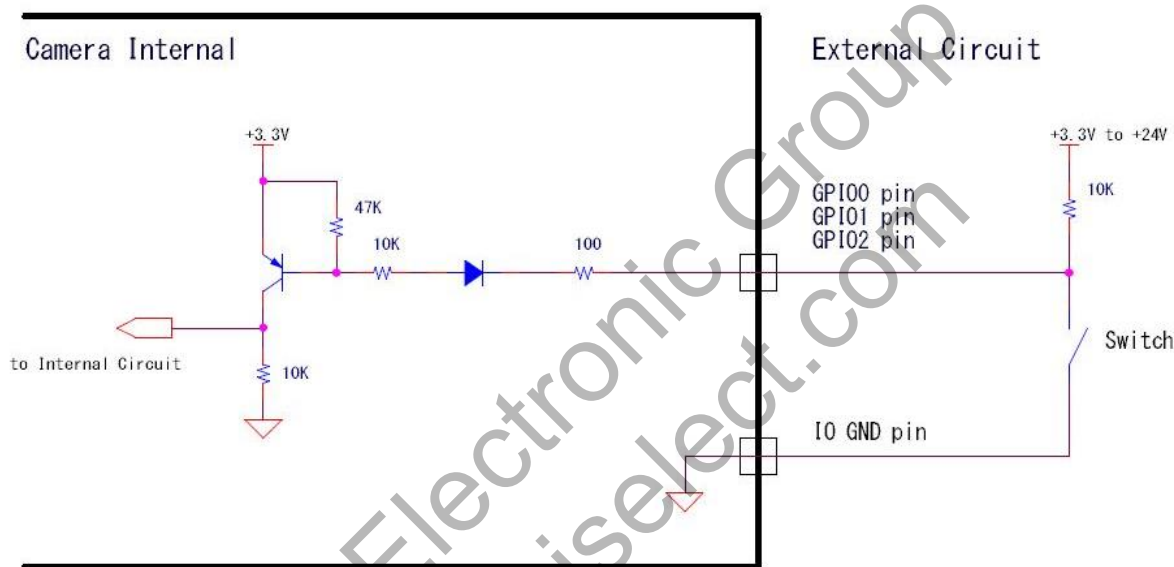

Input Response Characteristics

Response characteristics of General Purpose Input are shown in following diagrams

tIPDHL	0.13 μseconds
tIPDLH	6.54 μseconds

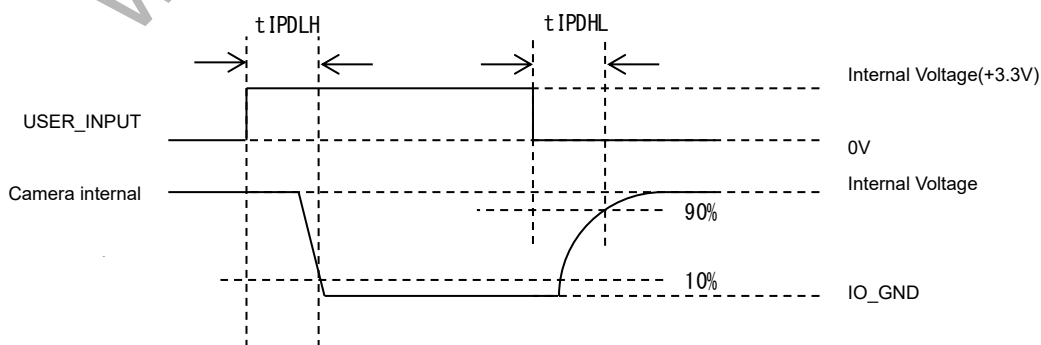

Capable input trigger's pulse width is

Positive Trigger: More than tIPDLH

Negative Trigger: More than tIPDHL

5.5.4 Reference Output Circuit

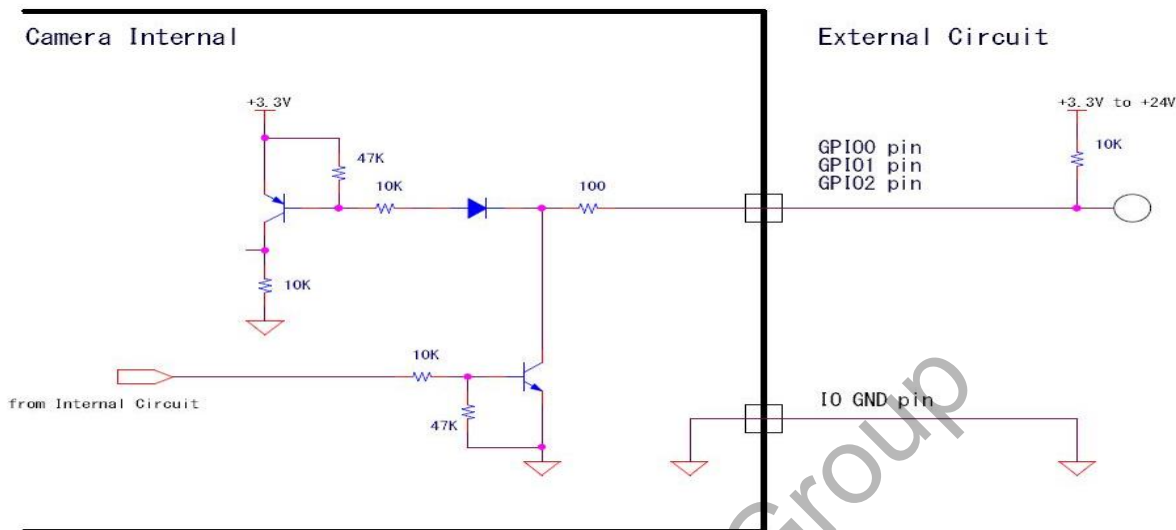

Output Response Characteristics

Response characteristics of General Purpose output are shown in diagram below. Pulse width is configurable through software.

Please refer to the following response timing table.

	VCCext			
	OPEN (*1)	5 V	12 V	24 V
tOPDHL	0.21 μseconds	0.25 μseconds	0.37 μseconds	0.51 μseconds
tOPDLH	10.40 μseconds	2.69 μseconds	2.68 μseconds	2.61 μseconds

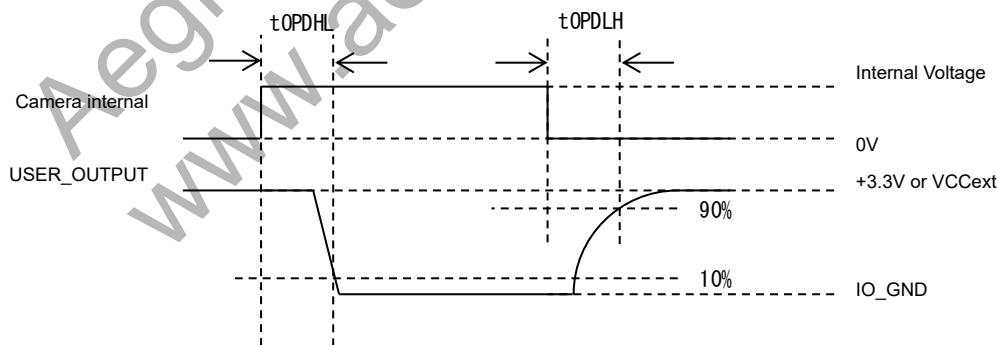

(*1) Measured on +3.3V internal Voltage.

5.5.5 LensConnect Lens Connector

HR10A-7R-6SB (Hirose) or equivalent.

This connector is for lens control for LensConnect lens.

Pin assignment

Pin No.	Signal Name	IN/OUT
1	PWR	-
2	GND	-
3	SDA	IN/OUT
4	SCL	OUT
5	TRG	IN
6	GND	-

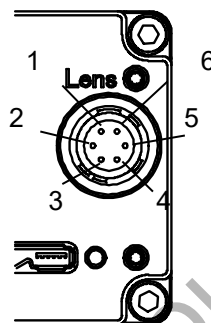

Input Output DC characteristics

Pin No.	Signal Name	Function	IN/OUT	Voltage		Current
				Low Voltage	Low Voltage	
1	PWR	Power	-	+5V (+/- 10%)		1A
2	GND	GND	-	-		-
3	SDA	Serial data line (I2C) (*1)	IN/OUT	0 to +1.5V	+3.5 to +5.5V	-
4	SCL	Serial data clock (I2C) (*1)	IN/OUT	0 to +1.5V	+3.5 to +5.5V	-
5	TRG	Trigger out	IN	0 to +0.8V	+2.0 to +3.3V	-
6	GND	GND	-	-		-

(*1) I2C-IF is supported clock stretch function. The level of signal is +5V.

6 Sensor Information

6.1 Pixel Transferring Image

STC-SBS500U3V-LCNT (Monochrome)

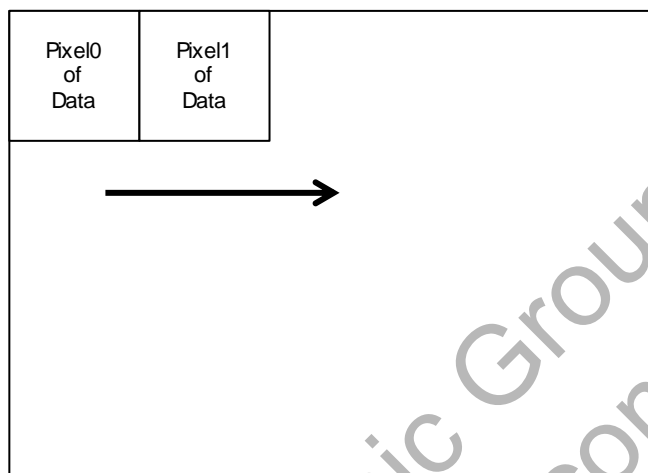

Pixel (n) of Data: nth pixel being transferred

STC-SCS500U3V-LCNT (Color)

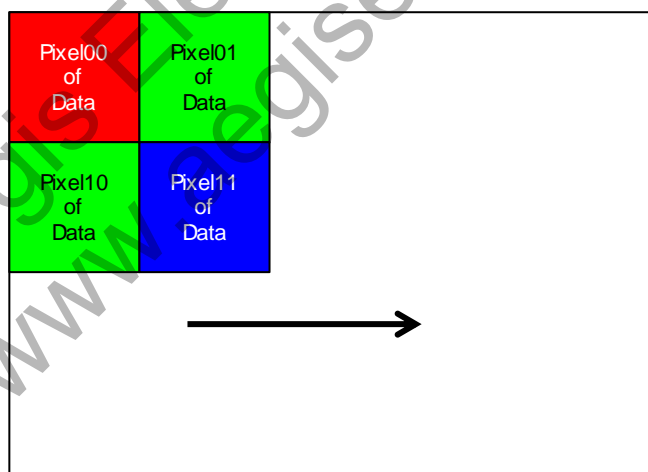

Pixel (m, n) of Data: nth pixel of the mth line being transferred

7 Image Acquisition and Camera Operational Modes (GenICam)

Please refer to another chapter for the method of switching Trigger.

GenICam Parameters

TriggerSelector	IEnumeration Type	Select Trigger function
TriggerMode	IEnumeration Type	Select ON / OFF which was selected function on TriggerSelector On: Trigger function ON, Off: Trigger function Off
TriggerSource	IEnumeration Type	Set Trigger Source which was selected function on TriggerSelector Software: Trigger control through TriggerSoftware command LineN: Trigger control through hardware trigger (N: Line number)
ExposureMode	IEnumeration Type	Select Exposure mode

Please refer to IO function for the (*) Line.

7.1 Free run

Free run mode outputs the camera image continuously.

In order to run Free run Mode, all trigger functions must be set to OFF via the TriggerMode.

Exposure time determines ExposureMode. When ExposureMode is turned off, the frame exposure will complete.

When ExposureMode is set to Timed, the ExposureTime value will be set as the exposure time.

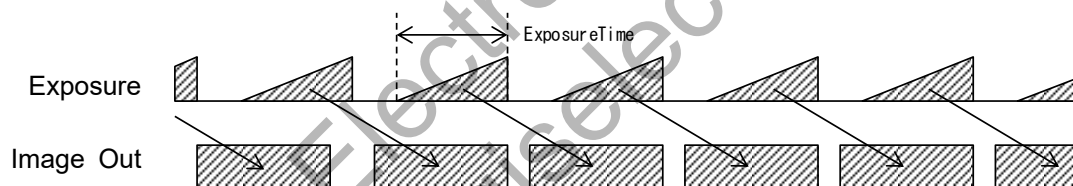

(*) The camera is set to Free run mode as the default mode.

7.2 Trigger Mode

This trigger consists of Frame Start, Exposure Start and Exposure End.

1) Frame Start

This function has the capability to acquire an image from exposure through the trigger.

The Frame Start function can be enabled when "FrameStart" is selected on TriggerSelector and the TriggerMode is set to "On".

This function supports "Edge Preset" trigger and "Pulse Width" trigger with trigger signal. This function can control exposure through ExposureMode.

2) Exposure Start, Exposure End

This function has the capability to acquire an image from Exposure Start to Exposure End. Exposure Start trigger is pair of Exposure End.

ExposureStart and ExposureEnd are selectable on TriggerSelector. Exposure Start function and Exposure End function can be enable through each TriggerMode On.

This function is only enabled when ExposureMode set TriggerControlled. If Exposure Mode did not set TrigerControlled, camera exposure and image acquisition do not work.

(* Please do not apply the Trigger through maximum frame rate on TriggerMode. When Trigger applies within sensor Readout as exposure end, camera interrupted Readout.

Aegis Electronic Group
www.aegiselect.com

7.2.1 Frame Start Trigger (Edge Preset)

The exposure synchronizes trigger signal.

The value on ExposureTime is actual exposure time.

When the polarity on LineInverter is positive (false), the Exposure starts on the rising edge of trigger.

When the polarity on LineInverter is negative (true), the Exposure starts on the falling edge of trigger.

To work the camera under this mode, as following setting have to be set.

- ExposureMode: Timed
- TriggerSelector: FrameStart
- TriggerMode: On

(*) On TriggerMode except FrameStart should be set Off.

Timing

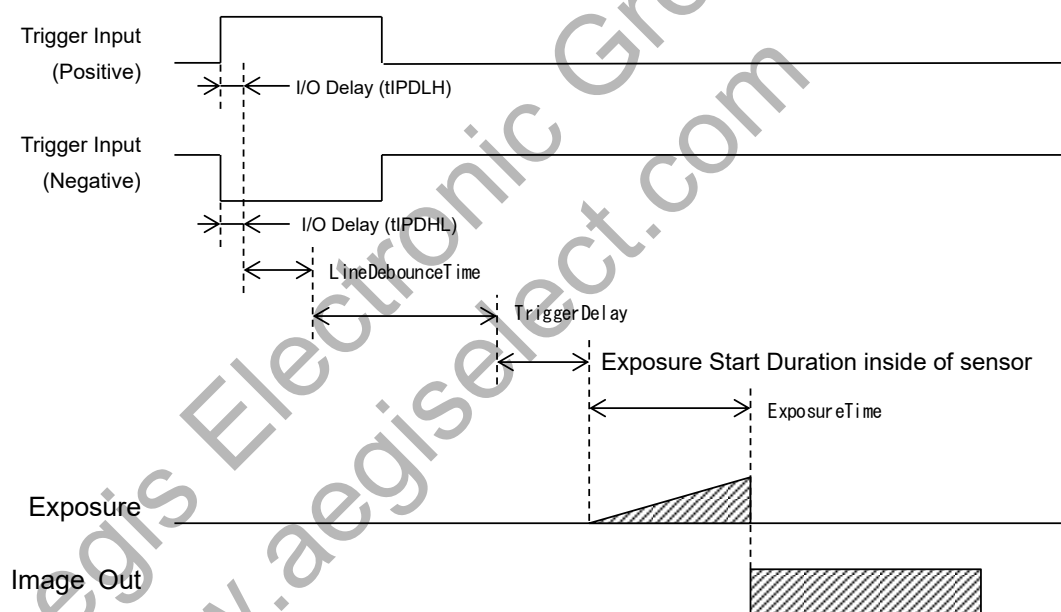

Delay time on exposure start timing in the sensor **Jitter** (unit: μ seconds)

Image Output Format	STC-SBS500U3V-LCNT
	STC-SCS500U3V-LCNT
8bits	0 to 13.4
10bits	
10bits Packed	
12bits	
12bits Packed	

7.2.2 Frame Start Trigger (Pulse Width Trigger)

When operating in this mode, the exposure synchronizes the trigger signal.

The exposure time can be controlled by the pulse width of Frame Start trigger.

When the polarity on the LineInverter is positive (false), the exposure can be controlled at a period of High level of input trigger signal.

When the polarity on the LineInverter is negative (true), the exposure can be controlled at a period of Low level of input trigger signal.

To operate the camera in this mode, the following settings have to be set.

- ExposureMode: TriggerWidth
- TriggerSelector: FrameStart
- TriggerMode: On

(*) On TriggerMode except FrameStart should be set Off.

Timing

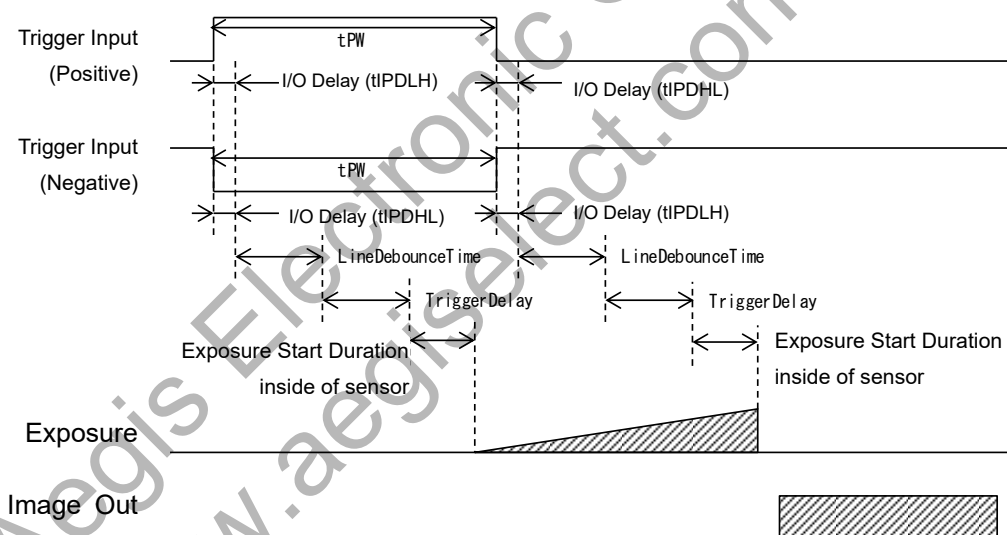

Delay time on exposure start timing in the sensor **Jitter** (unit: μ seconds)

Image Output Format	STC-SBS500U3V-LCNT
	STC-SCS500U3V-LCNT
8bits	0 to 13.4
10bits	
10bits Packed	
12bits	
12bits Packed	

7.2.3 Exposure Start Trigger, Exposure End Trigger

Exposure Start trigger determines exposure start timing, Exposure End trigger determines exposure end timing.

To operate the camera under this mode, the following settings have to be set.

- Exposure Mode: TriggerControlled
 - Selects TriggerSelector: ExposureStart, and TriggerMode: On
 - Selects TriggerSelector: ExposureEnd, and TriggerMode: On
- (*) On TriggerMode except FrameStart should be set Off.

Timing

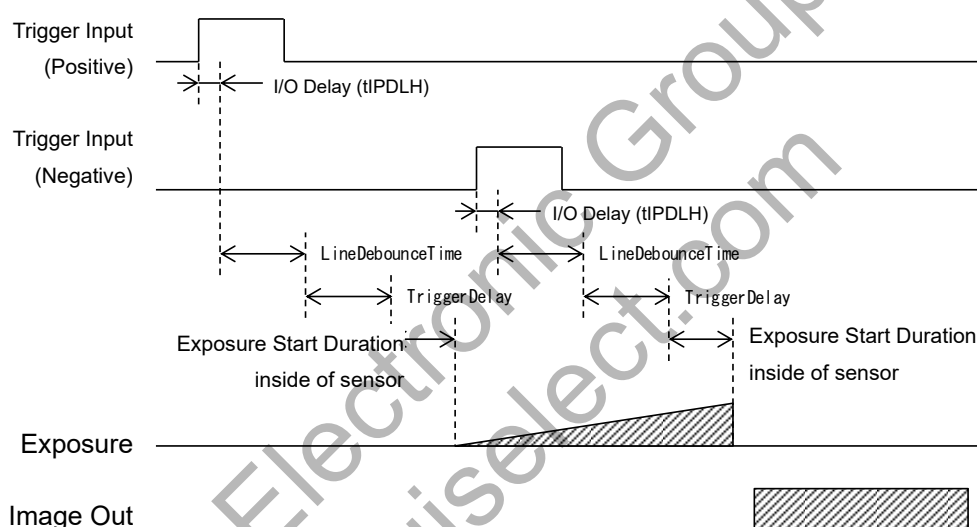

- (*) When all TriggerMode (Frame Start trigger, Exposure Start trigger, Exposure End) are On, camera's behavior depends on ExposureMode setting.
When the ExposureMode sets the TriggerControl, this function works through Trigger Start/End Trigger
This function works through Frame Start trigger for the remainder of the ExposureMode.

Delay time on exposure start timing in the sensor **Jitter** (unit: μ seconds)

Image Output Format	STC-SBS500U3V-LCNT STC-SCS500U3V-LCNT
8bits	0 to 13.4
10bits	
10bits Packed	
12bits	
12bits Packed	

7.2.4 Trigger Software

This function can apply either external signal or a software command as the trigger.

The software trigger can be applied through the "execute Trigger Software" command when the trigger is selected on the TriggerSelector.

7.3 Burst Trigger

When selecting the burst trigger (Frame Burst Start) operation, number of images acquiring by one trigger signal with minimum acquisition interval. The number of acquisition images can be set at AcquisitionBurstFrameCount.

Another trigger signal input while acquiring images with burst trigger, is invalid.

(This function is available from serial number: 23Bxxxx)

To work the camera under this mode, as following setting have to be set.

- TriggerSelector: FrameBurstStart
- TriggerMode: On

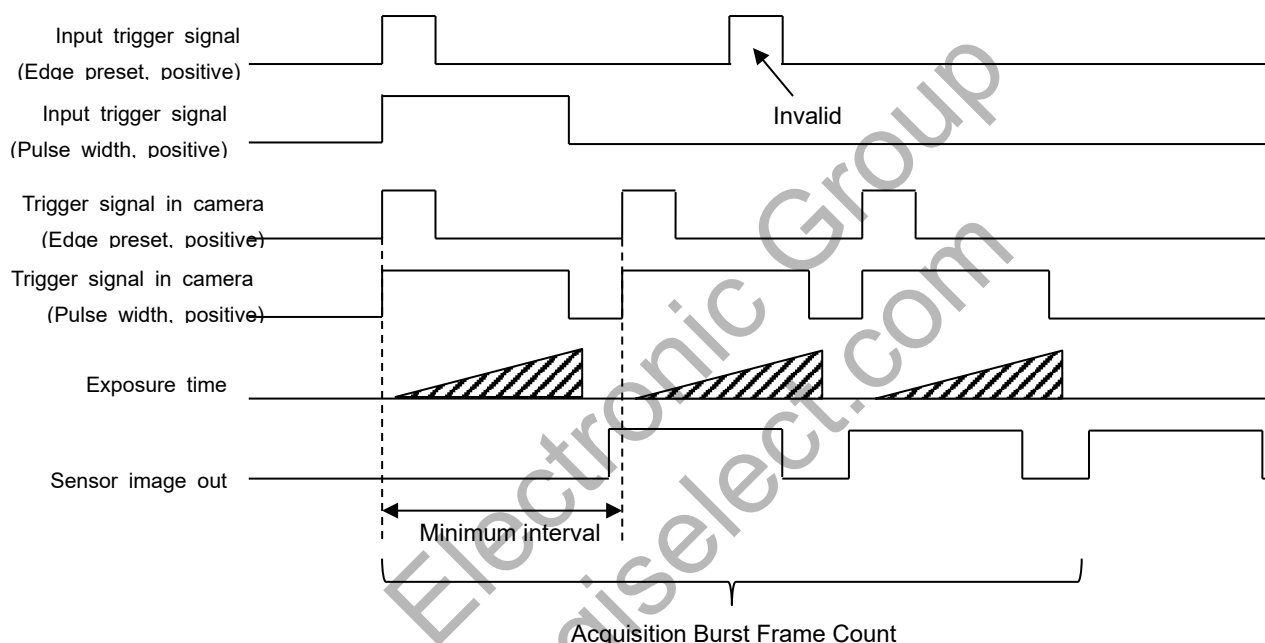

8 IO Function

This chapter describes the IO functions.

In this chapter, the IO Port places as "Line". The follow chart details the relationship of the Line and IO Port.

IO Port Pin No.	Signal Name	Line number
2	GPIO2	Line2
3	GPIO1	Line1
4	GPIO0	Line0

GenICam Parameters

LineSelector	IEnumeration Type	Select Line
LineMode	IEnumeration Type	Switch input / output direction for the Line that was selected at LineSelector. Input: set as input, Output: set as output
LineInverter	IBoolean Type	Switch polarity inversion ON / OFF for the Line that was selected at LineSelector. False: polarity inversion Off (Active-High), True: polarity inversion On (Active-Low)
LineStatus	IBoolean Type	Line status (High / Low)
LineSource	IEnumeration Type	Set function for the Line that was selected at LineSelector
UserOutputSelector	IEnumeration Type	Select UserOutput
UserOutputValue	IBoolean Type	Switch voltage level of UserOutput that was selected at UserOutputSelector False: Low voltage level, True: High voltage level

8.1 Input Port Function

This function sets the input on LineMode, then assigns Line as the input.

The following functions can be assigned as input.

8.1.1 Trigger Input

When select "input" assign port at the TriggerSource, the input signal can be assigned as Trigger.

The input signal can be switched to Active-Low (LineInverter: true) or Active-High (LineInverter: false).

(*) When the Line polarity changing by Line Inverter, the active polarity of input trigger signal is changed.

8.1.2 LineStatus

This function monitors the signal status on the input Line.

The High level (LineStatus: true) or Low level (LineStatus false) status can be seen through the software.

8.1.3 Line Debouncer

Line Debouncer can reduce the wrong input signal detection that is noise on the signal or chattering, by the filtering input signal.

GenICamParameters

LineDebounceTime	Integer Type	Line Debounce Time Range: 0 to 10,000 μ seconds, Default: 1 μ seconds
------------------	--------------	--

Timing

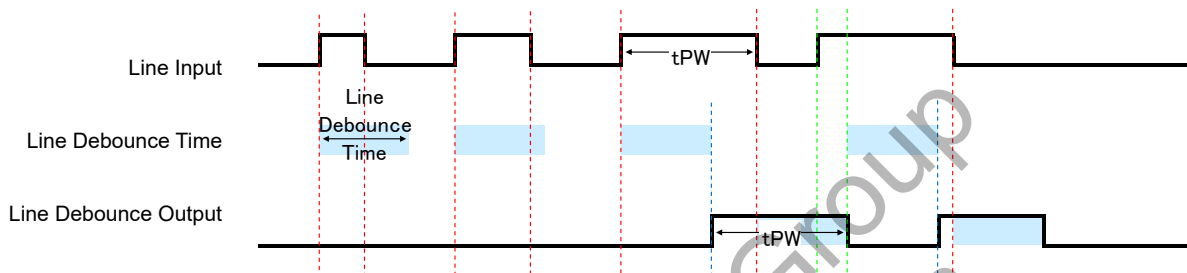

8.1.4 Trigger Delay

As mentioned in the previous chapter, "Image acquisition and Camera Mode", each trigger can add to the duration of the input signal

This TriggerDelay can add to the duration per μ second.

GenICam Parameters

TriggerDelay	Integer Type	Trigger Delay Range: 0 to 262,143 μ seconds, Default: 0 μ second
--------------	--------------	---

8.2 Output Port Function

This function sets the Output to LineMode, and then the Line is assigned as the output.

The following functions can be assigned when the IO port is used as the output signal port.

8.2.1 LineSource

The following list shows the configurable functions available through the LineSource.

The function that describes as “Enable” on “Changeable Polarity” is the configurable polarity on the LineInverter (true, false).

No.	Function Name	Changeable Polarity
1)	Off (Default)	-
2)	User Output	-
3)	Trigger Out	Enable
4)	Exposure End Out	Enable
5)	Frame End Out	Enable
6)	Transfer End Out	Enable
7)	Strobe Out	Enable
8)	Exposure Active	Enable

- 1) Off (Disable)
Disable the output signal.
- 2) User Output (General Output)
High or Low level signal that sets on the software is output.
- 3) Trigger Out (Trigger Output)
The trigger signal that added “Trigger Out Delay (Output pulse delay time)” and “TriggerOutOnTime (Output pulse width)” is output.
- 4) Exposure End Out (Exposure End)
“TriggerOutOnTime (Output pulse width)” activation time signal with set “TriggerOutDelay (Output pulse delay time)” is output when the expose was finished.
- 5) Frame End Out (Sensor Readout End)
“TriggerOutOnTime (Output pulse width)” activation time signal with set “TriggerOutDelay (Output pulse delay time)” is output when the sensor read out was finished.
- 6) Transfer End Out (Transfer End Output)
“TriggerOutOnTime (Output pulse width)” activation time signal with set “TriggerOutDelay (Output pulse delay time)” is output when one frame image transferring from camera was finished.
- 7) Strobe Out (Strobe Output)
“StrobeOutOnTime (Output pulse width)” activation time signal with set “StrobeOutDelay (Strobe output delay time)” is output when the trigger signal is received.
- 8) Exposure Active (In Exposure Period)
The signal that activation time is exposure time is output.
(*) Actual exposure period = Output signal pulse width + Minimum exposure time 13.73 μseconds

Line Source Timing

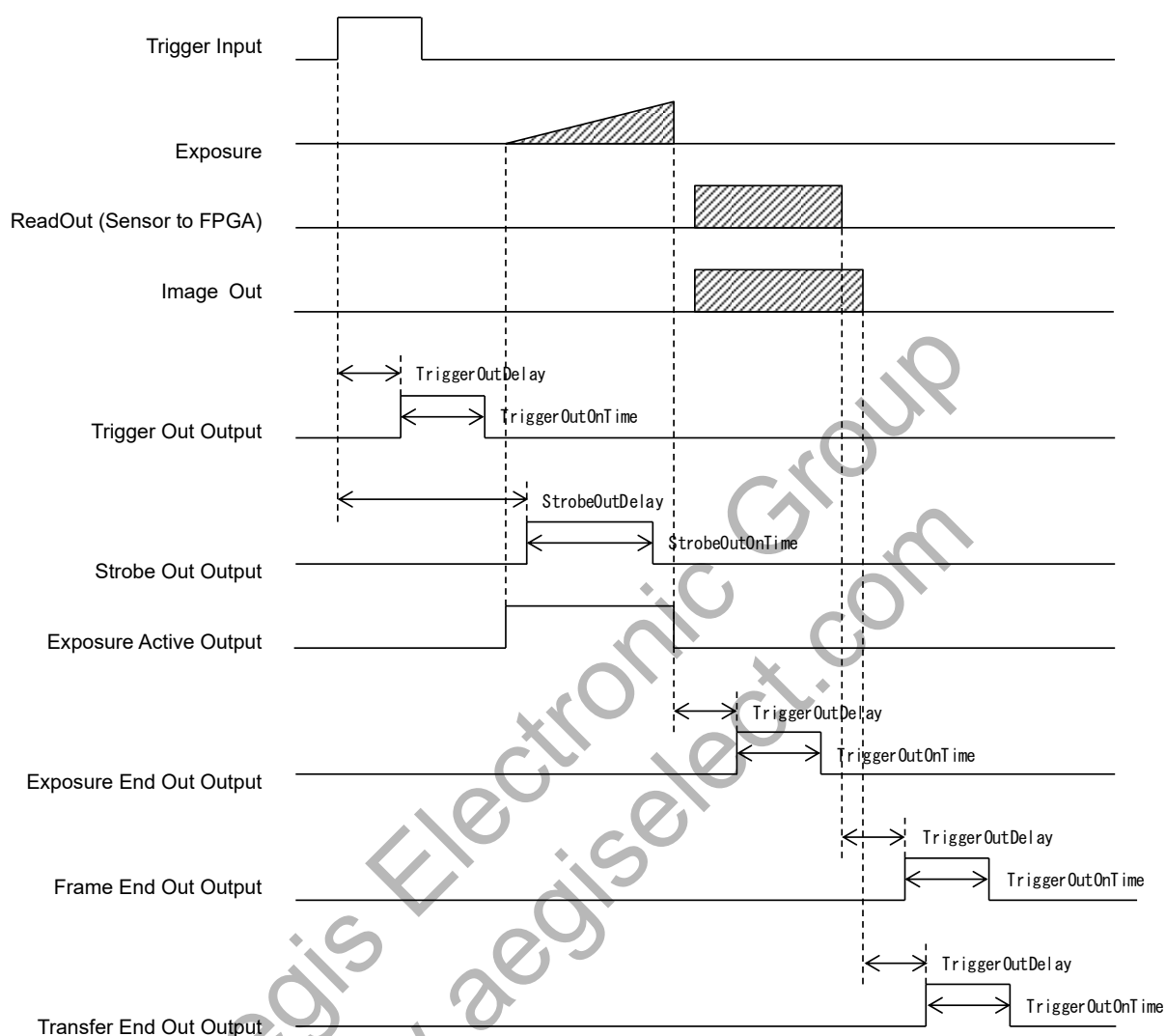

(* This timing chart does not include the delay of the IO circuit

(* The trigger port in this chart describes Frame Start trigger as an example

(* Trigger Out and Strobe Out do not output from the camera for Exposure Start trigger and Exposure End trigger

8.2.2 User Output

High or low level signal that was configured on the software is output.

Setting Procedure

Selects LineN (N: any number from 0, 1 or 2)

- 1) Sets the UserOutputN (N is Line number) as LineSource
- 2) Selects UserOutputN (N is same as selected Line number on UserOutput) on UserOutputSelector
- 3) Sets the value (True: High level, False: Low level) on UserOutputValue

8.2.3 Line Status

Monitor the status on output port.

Monitor the output voltage level High (LineStatus: true) or Low (LineStatus: false) through the software.

8.2.4 Output signal duration setting and Pulse width setting

Some selectable functions can be modified in order to add to the duration or pulse width on LineSource.

The configurable parameters are shown in the chart below.

Please refer to LineSource for the applicable functions of Parameters.

GenICamParameters

TriggerOutDelay	Integer Type	Trigger Out Delay Time Range: 0 to 262,143 μ seconds, Default: 0 μ second
TriggerOutOnTime	Integer Type	Trigger Out On Time Range: 4 to 262,143 μ seconds, Default: 32 μ seconds
StrobeOutDelay	Integer Type	Strobe Out Delay Time Range: 0 to 262,143 μ seconds, Default: 30 μ seconds
StrobeOutOnTime	Integer Type	Strobe Out On Time Range: 4 to 262,143 μ seconds, Default: 32 μ seconds

8.3 Hardware Reset

The hardware reset can be done by CAM_RESET port.

Sets On (Default: Off) at LineDeviceResetMode, and apply the Low voltage in 5 seconds on CAM_RESET port then camera rest.

9 Camera Functions

This chapter describes the camera functions.

9.1 ROI (Region of Interest)

This sets the ROI in order to output the selected area of image.

The frame rate increases when reducing the height of image. The frame rate does not change when reducing the width of image.

9.1.1 ROI (One Region)

GenICam Parameters

Width	Integer Type	Horizontal (Pixel) size Sets the width of image. "Width + OffsetX" should not exceed the maximum width.
Height	Integer Type	Vertical (Line) size Sets the height of image. "Height + OffsetY" should not exceed the maximum height.
OffsetX	Integer Type	Horizontal (Pixel) offset Default: 0 Setting steps: 4 pixels
OffsetY	Integer Type	Vertical (Line) offset Default: 0 Setting steps: 4 lines

The parameters define as following chart.

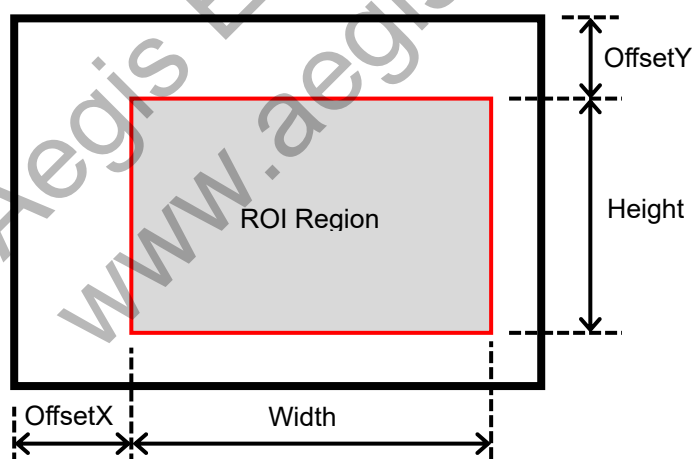

(*) Width, Height, OffsetX, OffsetY setting steps is the same in Binning and Decimation.

Width / Height setting range

		STC-SBS500U3V-LCNT STC-SCS500U3V-LCNT
Width	Setting range:	64 to 2,448 pixels (* 2,432 pixels is maximum width on Packed output)
	Default:	2,448 pixels
	Setting steps	16 pixels unit (* 64 pixels unit on Packed output)
Height	Setting range:	32 to 2,048 lines
	Default:	2,048 lines
	Setting steps	4 lines

Aegis Electronic Group
www.aegiselect.com

9.2 Pixel Format

The image format from camera can be set on the Pixel Format.

GenICam Parameters

PixelFormat	Enumeration Type	Pixel Format
-------------	------------------	--------------

The following chart shows the available Pixel Formats on the camera:

Output Bit	PixelFormat	
	Monochrome Model	Color Model
8bits	Mono8	BayerRG8
10bits	Mono10	BayerRG10
10bits Packed	Mono10p	BayerRG10p
12bits	Mono12	BayerRG12
12bits Packed	Mono12p	BayerRG12p

Each format specified on GenICam PFNC (Pixel Format Naming Convention).

9.3 Decimation

When using Decimation mode, the decimated image can be output.

The images below show decimated pixels (red squares) where they are output.

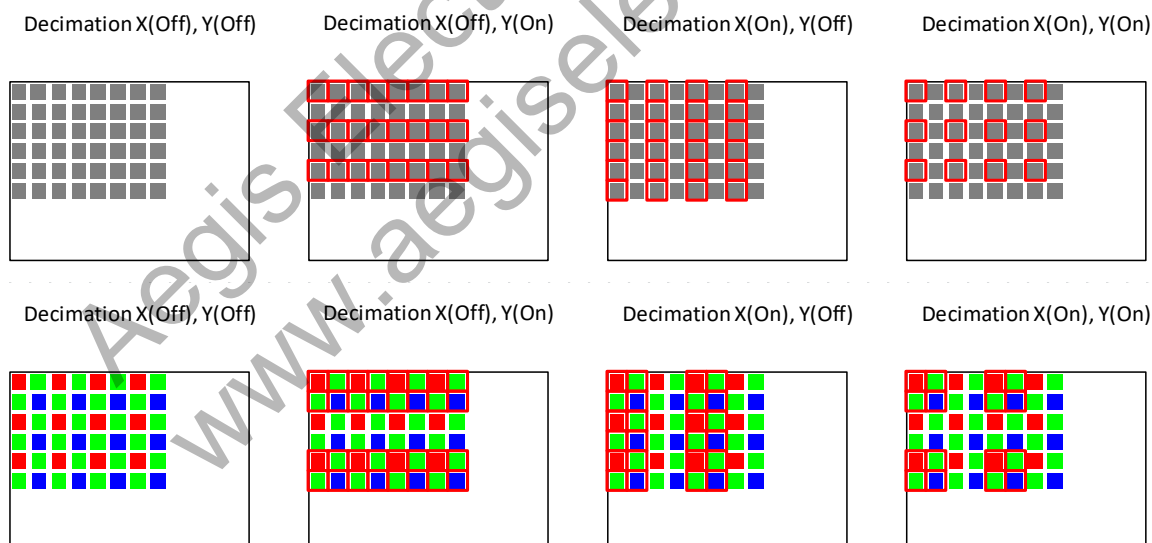

GenICam Parameters

DecimationHorizontal	Integer Type	Sets decimation on horizontal direction 1: Disable Decimation, 2: Decimate one of two pixels
DecimationVertical	Integer Type	Sets decimation on vertical direction 1: Disable Decimation, 2: Decimate one of two pixels

9.4 Image Flip

Flip the image through ReverseX and ReverseY.

GenICam Parameters

ReverseX	IBoolean Type	Switch ON / OFF at Horizontal False: Horizontal Flip Off, True: Horizontal Flip On. Default: False
ReverseY	IBoolean Type	Switch ON / OFF at Vertical False: Vertical Flip Off, True: Vertical Flip On. Default: False

Reverse X(Off), Y(Off)

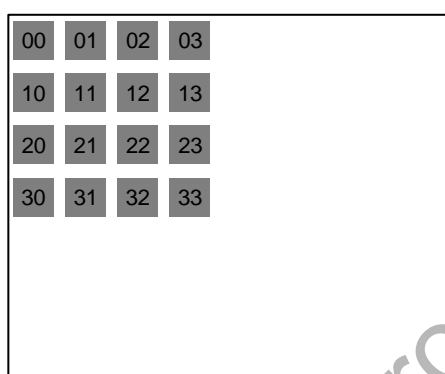

Reverse X(Off), Y(On)

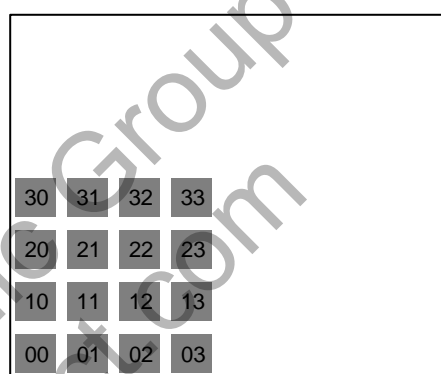

Reverse X(On), Y(Off)

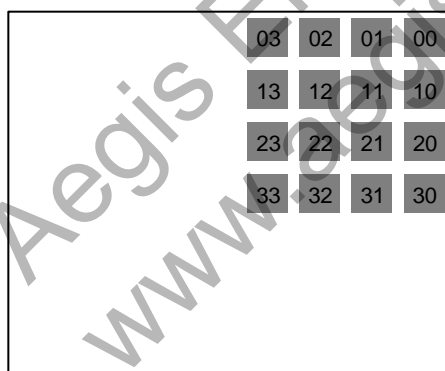

Reverse X(On), Y(On)

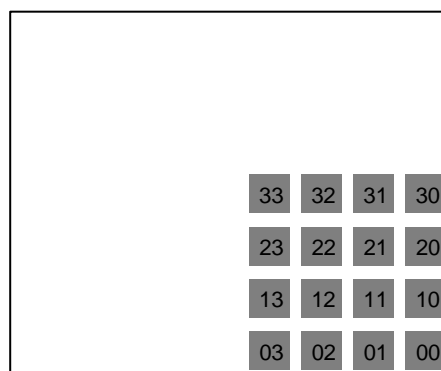

Reverse X(Off), Y(Off)

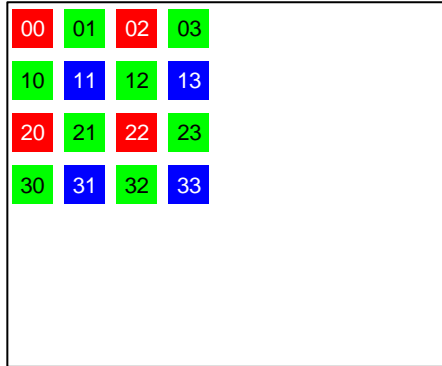

Reverse X(Off), Y(On)

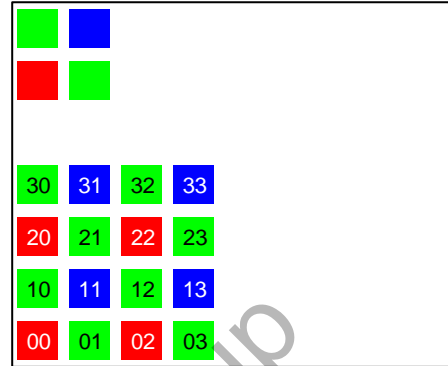

Reverse X(On), Y(Off)

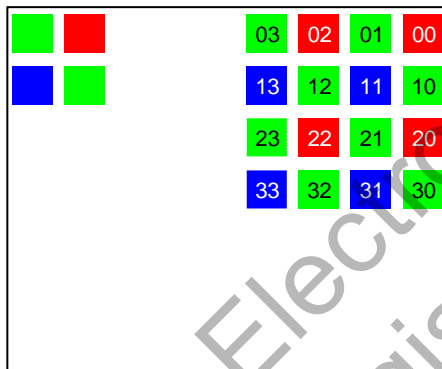

Reverse X(On), Y(On)

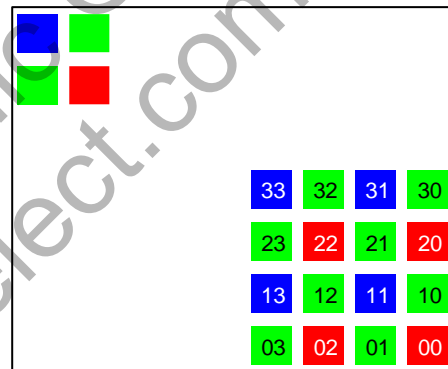

(*) When the image is flipping for color model, the pixel array is also flipped.

9.5 Gain

The gain has Analog Gain, Digital Gain and White Balance Gain.

(*) When increasing the gain level may increase noise level.

Please check the image on actual environment when adjusting brightness of image.

9.5.1 Analog Gain

This parameter sets the analog gain.

Selects "AnalogAll" at "GainSelector", sets gain at "Gain [GainSelector]".

GenICam Parameters

GainSelector	IEnumeration Type	Selects control gain AnalogAll: Analog Gain
Gain	IFloat Type	Analog Gain Range: 0 to 432 Default: 0
AnalogGainOffsetMode	IEnumeration Type	Selects Enable / Disable analog offset gain (*2) On: Enable offset gain Off: Disable offset gain Default: On

(*1) When selecting "Off" at AnalogGainOffsetMode, range of analog gain is extending to 0 to 480.

(*2) The analog offset gain uses for adjusting brightness variation of camera at production.

The factory default of offset gain is "On", but offset gain is disabling and extend range of analog gain when selecting "Off".

However, when selecting "Off" for offset gain, sensitivity and brightness variation become noticeable due to disabling factory offset gain adjustment.

9.5.2 Digital Gain

This parameter sets the digital gain.

Selects "DigitalAll" at "GainSelector", sets gain at "Gain [GainSelector]".

GenICam Parameters

Gain [DigitalAll]	IFloat Type	Digital Gain Range: 0 to 64, Default: 0
-------------------	-------------	--

Digital Gain Formula

Gain (x times) = 1 + (Gain [DigitalAll] / 64)

9.5.3 White Balance Gain (Only available for the color model)

This parameter sets the Bayer patten color gain.

Sets gain at “BalanceRatio” for selected color at “BalanceRatioSelector”.

GenICam Parameters

BalanceRatio [BalanceRatioSelector]	IFloat Type	White Balance Gain Range: 0 to 511, Default: Red: 177, Green: 128, Blue: 290
-------------------------------------	-------------	--

White Balance Gain Formula

Gain (x times) = BalanceRatio [BalanceRatioSelector] / 128

9.6 Black Level

This parameter sets the black level (the clamp level for the black signal).

Sets the black level at “BlackLevel [BlackLevelSelector]”.

The lower limit of the signal is clamped at this setting level. The signal does not lower than this.

(*) “AnalogAll” is only selectable at “BlackLevelSelector”.

GenICam Parameters

BlackLevel [BlackLevelSelector]	IFloat Type	Black Level, Default: 7.9375 (on 8bits output) Range: 8bits output: 0 to 31 10bits output: 0 to 127 (10bits Packed outputs same as this mode) 12bits output: 0 to 511 (12bits Packed outputs same as this mode)
---------------------------------	-------------	---

9.7 ALC (Auto Light Control)

ALC has AGC (Auto Gain Control) and auto exposure function. It can be set individually.

The camera parameters adjust automatically based on current brightness of image, to achieve the target brightness with ALC function.

GenICam Parameters

AutoLightTarget	Integer Type	Target Brightness Range: 0 to 255, Default: 127
-----------------	--------------	--

Target Brightness Formula (AutoLightTarget)

8bits output: Target Brightness (Gradient) = AutoLightTarget

10bits output: Target Brightness (Gradient) = AutoLightTarget × 4

12bits output: Target Brightness (Gradient) = AutoLightTarget × 16

9.7.1 ALC Control Method

The brightness of image adjusts to achieve “AutoLightTarget” brightness with AGC and auto exposure function.

When AGC and auto exposure are enabled, at first, the brightness adjusts with auto exposure function. If the brightness does not achieve “AutoLightTarget” brightness with auto exposure function, the brightness adjusts with the AGC function.

9.7.2 AGC (Auto Gain Control)

The gain adjusts automatically to achieve the target brightness.

When the current brightness of image was darker than target brightness, increases the gain up to "GainAutoLimitMax".

When the current brightness of image was brighter than target brightness, decrease the gain down to "GainAutoLimitMin".

GenICam Parameters

GainAuto	IEnumeration Type	Switch ON / OFF for AGC Continuous: AGC On, Off: AGC Off. Default: Off
GainAutoLimitMax	IFloat Type	Sets the maximum gain for AGC Range: 0 to 192, Default: 127 This value sets as maximum gain for AGC.
GainAutoLimitMin	IFloat Type	Sets the minimum gain for AGC Range: 0 to 192, Default: 0 This value sets as minimum gain for AGC.

9.7.3 Auto Exposure

The exposure time adjusts automatically to achieve the target brightness.

When the current brightness of image was darker than target brightness, extend exposure time up to "ExposureAutoLimitMax".

When the current brightness of image was brighter than target brightness, reduce exposure time down to "ExposureAutoLimitMin".

GenICamParameters

ExposureAuto	IEnumeration Type	Switch ON / OFF for Auto Exposure Continuous: Auto Exposure On, Off: Auto Exposure Off. Default: Off
ExposureAutoLimitMax	IFloat Type	Sets the maximum exposure time in μ second unit Range: Same as Exposure Time Range for each PixelFormat
ExposureAutoLimitMin	IFloat Type	Sets the minimum exposure time in μ second unit Range: Same as Exposure Time Range for each PixelFormat

9.7.4 The setting procedure of ALC

Please follow setting procedure shown below.

Setting Procedure

1. Sets "Timed" at "ExposureMode" (When using Auto Exposure)
2. Sets "Continuous" at "ExposureAuto" (When using Auto Exposure)
3. Sets "ExposureAutoLimitMax" (When using Auto Exposure)
4. Sets "ExposureAutoLimitMin" (When using Auto Exposure)
5. Sets "Continuous" at "GainAuto" (When using AGC)
6. Sets "GainAutoLimitMax" (When using AGC)
7. Sets "GainAutoLimitMin" (When using AGC)

9.8 White Balance (Only available for the color model)

The color compensates by the gain adjustment for each individual color.

The gain for each color has to adjust to same brightness with the flat white target.

The white balance control methods are the listed in the below:

- Disable
- Manual (Off)
- Auto White Balance (Continuous)
- Push to set white balance (Once)

9.8.1 White balance control methods

GenICam Parameters

BalanceWhiteAuto	IEnumeration Type	White balance control method selection. Default: Off (Manual)
BalanceRatioSelector	IEnumeration Type	White balance control target color selection.
BalanceRatio	IFloat Type	Color gain setting for selected color selects at "BalanceRatioSelector".

9.8.2 Disable

Disabled white balance gain and each color gain set as x1.

Setting Procedure

1. Sets "Disable" at "BalanceWhiteAuto"

9.8.3 Manual (Off)

The optimized BalanceRatio (Red, Green or Blue) for the white balance.

Setting Procedure

1. Sets "Red" (when Red gain set) at "BalanceWhiteSelector"
2. Sets value at "BalanceRatio"
3. Sets "Green" at "BalanceWhiteSelector"
4. Sets value at "BalanceRatio"
5. Sets "Blue" (when Blue gain set) at "BalanceWhiteSelector"
6. Sets value at "BalanceRatio"
7. Sets "Off" at "BalanceWhiteAuto"

9.8.4 Auto White Balance (Continuous)

Optimizes white balance gain each frame automatically.

Setting Procedure

1. Sets "Continuous" at "BalanceWhiteAuto"

9.8.5 Push to Set White Balance (Once)

The white balance gain adjusts once after selecting this white balance method. Then each gain set to "BalanceWhite (Red, Green and Blue)".

Sets "Off" at "BalanceWhiteAuto" automatically after set "WhiteBalanceGain".

Setting Procedure

1. Sets the flat white target (To process white balance correctly)
2. Sets Once on BalanceWhiteAuto

Aegis Electronic Group
www.aegiselect.com

9.9 Gamma Table

The linearity of gradient of image can be correct by the gamma table on the camera.

GenICam Parameters

Gamma	IFloat Type	Gamma Range: 0.1 to 4.0, Default: 1.0
-------	-------------	--

Gamma Formula

For 12bits image

$$\text{Output data} = 4,096 \times \left(\frac{\text{Input data}}{4,096} \right)^\gamma$$

For 10bits image

$$\text{Output data} = 1,024 \times \left(\frac{\text{Input data}}{1,024} \right)^\gamma$$

For 8bits image

$$\text{Output data} = 256 \times \left(\frac{\text{Input data}}{256} \right)^\gamma$$

The input signal divides into 32 equal part and have 33 points of gamma table.

The between the points is generates by the linear interpolation.

For 12bits image (Gamma = 2.0)

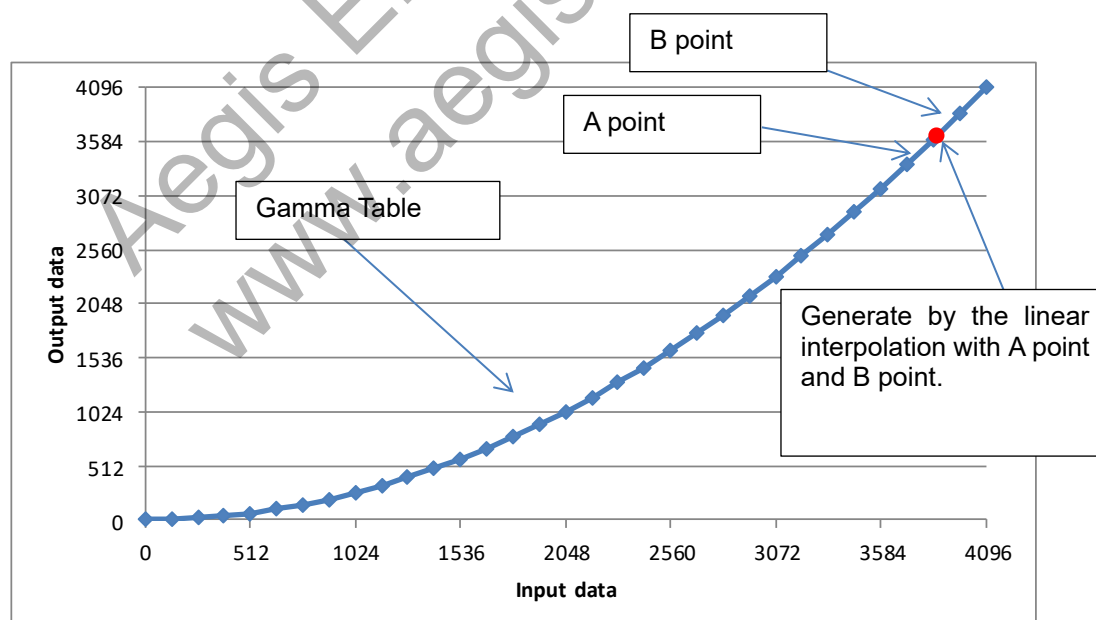

9.10 Save and load the camera settings

The camera has the camera setting save function, the camera setting including factory default loads function.

The camera has below two camera settings.

Default: The factory default settings (This setting cannot change)

UserSetX: Over writeable camera settings (X: 0 to 7)

These camera settings load from ROM to the register in the RAM on the camera and camera settings save to ROM. The camera settings saving and loading is controllable with Parameters (UserSetSelector, UserSetDefault), and commands (UserSetLoad, UserSetSave) in UserSetControl category of GenICam.

The details of the parameters and the functions are in the table below:

GenICam Parameters

UserSetSelector	IEnumeration Type	Select "Default" or "UserSet1" UserSetLoad or UserSetSave process for the selected settings.
UserSetLoad	ICommand Type	The camera settings load from ROM to the register in RAM.
UserSetSave	ICommand Type	The camera settings at the register in RAM save to ROM.
UserSetDefault	IEnumeration Type	Select which settings ("Default or UserSet X) load automatically when the camera power is on. This selection saves automatically.

9.10.1 Saving the Camera Settings

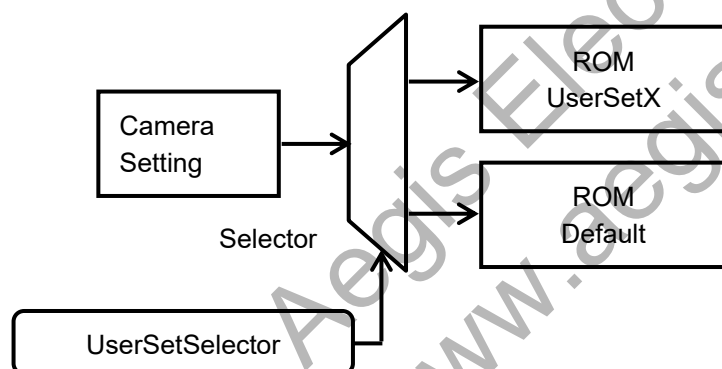

When UserSetSave is executing, the camera settings at the register in RAM are saved to the ROM that is selected at UserSetSelector.

Caution:

UserSetSave cannot execute when "Default" was selected at "UserSet Selector"

Setting Procedure

1. Selects "UserSetX" at "UserSetSelector"
2. Execute "UserSetSave"

9.10.2 Loading Camera Settings

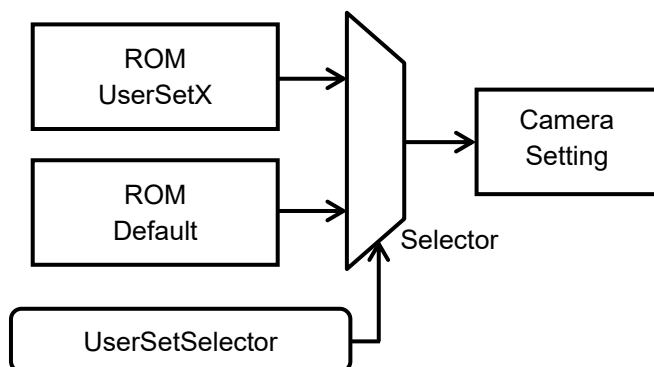

When UserSetLoad is executing, the camera settings load from the selected ROM that was selected at “UserSetSelector” to the register at RAM.

Setting Procedure

1. Select “UserSetX” (or Default) at “UserSetSelector”
2. Execute “UserSetLoad”

9.10.3 Loading Camera Settings when the Camera Power is on

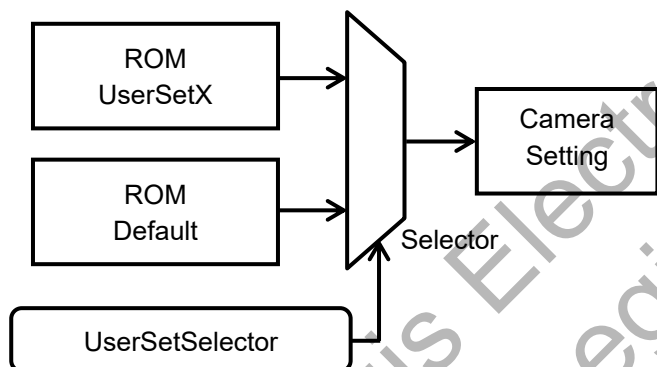

When the camera power is on, the camera settings load from the selected ROM that was selected at “UserSetDefault” to the register at RAM.

Setting Procedure

1. Set “UserSetX” or “Default” at “UserSetDefault”

9.10.4 Camera Settings Initialization

Please follow the below procedure for the camera settings put back to the factory default settings.

Setting Procedure

1. Selects “Default” at “UserSetSelector”.
2. Executes “UserSetLoad”.

9.11 Pixel Defect Correction

The defected pixel corrects with horizontally beside pixel information.

In the color camera, using same color of horizontally beside same pixel.

When consecutive defect pixels are selected, corrects up to 2 pixels.

GenICamParameters

PixelCorrectionAllEnabled	IBoolean Type	Switch ON / OFF for Pixel Defect Correction True: On, False: Off
PixelCorrectionIndex	Integer Type	Pixel Correction Index
PixelCorrectionX	Integer Type	Defect position on X coordinate for Index was selected at "PixelCorrectionIndex"
PixelCorrectionY	Integer Type	Defect position on Y coordinate for Index was selected at "PixelCorrectionIndex"
PixelCorrectionEnabled	IBoolean Type	Switch ON / OFF for pixel defect correction for Index was selected at "PixelCorrectionIndex" True: On, False: Off

9.12 Trigger

The description of trigger type and characteristic, please refer to the chapter "Image acquisition and Camera Mode".

9.12.1 Trigger Signal Process

When the external hardware or software signal is input to the camera, the following process are proceeding.

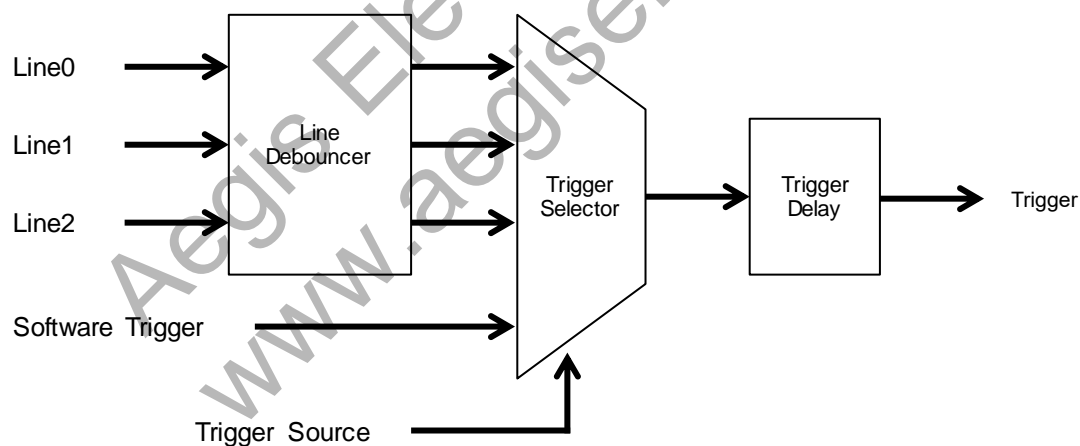

9.13 Device User ID

DeviceUserID provides the user access to the writable memory area.

Up to 64 bytes data can be stored (The data still remains, even the camera power is off)

When the data is less than 64 bytes, please add 0x00 at the end of data.

9.14 Event Control (Only available with USB3 Vision protocol)

The camera can be send notification of event inside of the camera to host controller.

GenICamParameters

EventSelector	IEnumeration Type	Select Event Function
EventNotification	IEnumeration Type	Switch On / Off for Event function that was selected at "EventSelector". On: Event function On, Off: Event function Off

9.14.1 The way to use Event

Please select the available event at "EventSelector" then select "On" at "EventNotification" then the event function is enabled.

9.14.2 Event Function

The event functions on the camera are as follows.

- 1) EventExposureStart
Send notification as event when expose starts in the camera.
EventID is 0x9002.
- 2) EventExposureEnd
Send notification as event when expose finishes in the camera.
EventID is 0x9001.

(*) The event occurrence frequently, the stream data transferring rate could be reduced because Event and Stream (image data) share USB bus.

9.15 Chunk Control

This function has is attached the additional image information to image data.

For example, the exposure time and gain information do not include in image data itself. However, Chunk data transfers parameters when image was acquiring.

GenICam Parameters

ChunkModeActive	IBoolean Type	Enable transfer Chunk data on Payload True: Enable Chunk data transfer, False: Disable Chunk data transfer,
ChunkSelector	IEnumeration Type	Select the transfer Chunk data
ChunkEnable	IBoolean Type	Enable Chunk data that was selected at "ChunkSelector" True: Enable Chunk data, False: Disable Chunk data

9.15.1 The way to use Chunk

Please enabled "Chunk data Active" then enabled "ChunkEnable" to enable Chunk Control.

Setting Procedure

1. To enable Chunk, set "Ture" at "ChunkModeActive"
2. Select "Chunk data type" at "ChunkSelector"
3. To enable Chunk, set "True" at "ChunkEnable"

9.15.2 Chunk Data

1) ChunkCounterValue

Transfer the value of Counter0 in the camera as Chunk data.
ChunkID is 0x00000001.

"FrameStart", "FrameEnd" or "FrameTrigger" can be set as Counter Event Source. Execute "CounterReset" to reset counter.

2) ChunkGain

Transfer the Gain when image was acquiring, as Chunk data.

ChunkGain contains AnalogAll, DigitalAll, Red, Blue and Green
ChunkID is 0x00000002.

3) ChunkBlackLevel

Transfer the BlackLevel when image was acquiring, as Chunk data.

ChunkBlackLevel contains AnalogAll and DigitalAll.
ChunkID is 0x00000003.

4) ChunkExposureTime

Transfer the exposure time when image was acquiring, as Chunk data.
ChunkID is 0x00000004.

5) ChunkGamma

Transfer the Gamma when image was acquiring, as Chunk data.
ChunkID is 0x00000005.

9.16 Device Sleep Mode

The device sleep mode can be switch between operation mode (live image) and sleep mode for camera operation.

GenICam Parameters

DeviceSleepMode	IEnumeration Type	Select the camera operation mode OFF: Operation mode (live image) (Default) ON: Sleep mode
-----------------	-------------------	--

When selecting “ON” at “DeviceSleepMode”, camera operation mode switch to “sleep mode” to reduce power consumption of camera.

The camera only accepts “DeviceSleepMode” parameter after select “ON” at “DeviceSleepMode”.

Please do not change other camera parameters after set “ON” at “DeviceSleepMode”.

Please do not start image acquisition image after set “ON” at “DeviceSleepMode”.

Please stop image acquisition before set “ON” at “DeviceSleepMode”.

Setting Procedure

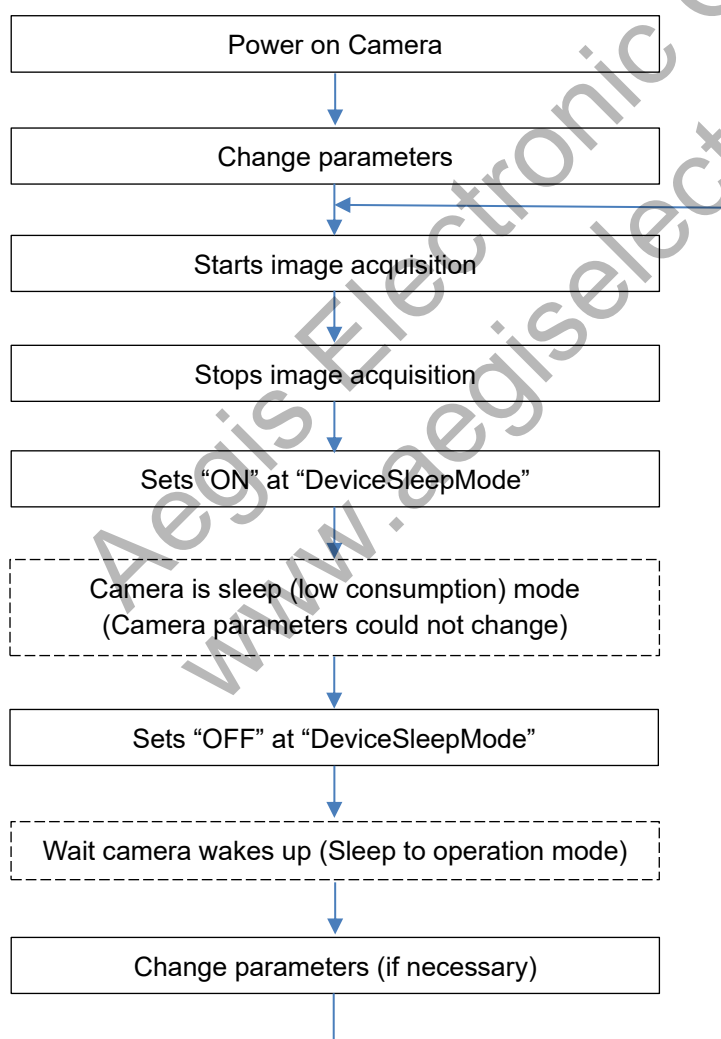

9.17 LensConnect Control

Control Zoom, Iris, etc. of lenses that are compatible with LensConnect control.

(*Available only with CBC's LensConnect compatible lenses as of December 2024).

There are four types of functions that can be controlled: Zoom, Iris, Focus and Optical Filter. Please check the lens specification sheet for details on the functions installed.

9.17.1 Zoom Function

This function controls zooming in/out.

GenICam Parameters

LensConnectZoomPositionValue	Integer Type	Specifies the position address of the motor for the Zoom function. The selection range varies for each lens.
LensConnectZoomInitialize	Enumeration Type	Initializes the motor for the Zoom function. When the camera starts up, it starts up with the initialization completed.
LensConnectZoomCountValue	Integer Type	Indicates the number of motor operations for the Zoom function.
LensConnectZoomCountMax	Integer Type	Indicates the maximum value of the motor specification for the Zoom function.

9.17.2 Focus Function

This function controls the focus.

GenICam Parameters

LensConnectFocusPositionValue	Integer Type	Specifies the position address of the motor for the Focus function. The selection range varies for each lens.
LensConnectFocusInitialize	Enumeration Type	Initializes the motor for the Focus function. When the camera starts up, it starts up with the initialization completed.
LensConnectFocusCountValue	Integer Type	Indicates the number of motor operations for the Focus function.
LensConnectFocusCountMax	Integer Type	Indicates the maximum value of the motor specification for the Focus function.

9.17.3 Iris Function

This function controls the Iris of the lens.

GenICam Parameters

LensConnectIrisPositionValue	Integer Type	Specifies the position address of the motor for the Iris function. The selection range varies for each lens.
LensConnectIrisInitialize	Enumeration Type	Initialises the motor for the Iris function. When the camera starts up, it starts up with the initialisation completed.
LensConnectIrisCountValue	Integer Type	Indicates the number of motor operations of the Iris function.
LensConnectIrisCountMax	Integer Type	Indicates the maximum value of the motor specification for the Iris function.

9.17.4 OpticalFilter Function

This function controls the Optical Filter.

GenICam Parameters

LensConnectOpticalFilterPositionValue	Integer Type	Specifies the position address of the motor for the OpticalFilter function. The selection range varies for each lens.
LensConnectOpticalFilterInitialize	Enumeration Type	Initializes the motor for the OpticalFilter function. When the camera starts up, it starts up with the initialization completed.
LensConnectOpticalFilterCountValue	Integer Type	Indicates the number of motor operations for the OpticalFilter function.
LensConnectOpticalFilterCountMax	Integer Type	Indicates the maximum value of the motor specification for the OpticalFilter function.

9.18 GenICam command list

9.18.1 DeviceControl

Name	Description
DeviceType	Returns the device type.
DeviceScanType	Scan type of the sensor of the device.
DeviceVendorName	Name of the manufacturer of the device.
DeviceModelName	Model of the device.
DeviceFamilyName	Identifier of the product family of the device.
DeviceManufacturerInfo	Manufacturer information about the device.
DeviceVersion	Version of the device.
DeviceFirmwareVersion	Version of the firmware in the device.
DeviceSerialNumber	Device's serial number. This string is a unique identifier of the device.
DeviceUserID	User-programmable device identifier.
DeviceSFNCVersionMajor	Major version of the Standard Features Naming Convention that was used to create the device's GenICam XML.
DeviceSFNCVersionMinor	Minor version of the Standard Features Naming Convention that was used to create the device's GenICam XML.
DeviceSFNCVersionSubMinor	Sub minor version of Standard Features Naming Convention that was used to create the device's GenICam XML.
DeviceManifestEntrySelector	Selects the manifest entry to reference.
DeviceManifestXMLMajorVersion	Indicates the major version number of the GenICam XML file of the selected manifest entry.
DeviceManifestXMLMinorVersion	Indicates the minor version number of the GenICam XML file of the selected manifest entry.
DeviceManifestXMLSubMinorVersion	Indicates the sub minor version number of the GenICam XML file of the selected manifest entry.
DeviceManifestSchemaMajorVersion	Indicates the major version number of the schema file of the selected manifest entry.
DeviceManifestSchemaMinorVersion	Indicates the minor version number of the schema file of the selected manifest entry.
DeviceTLType	Transport Layer type of the device.
DeviceTLVersionMajor	Major version of the Transport Layer of the device.
DeviceTLVersionMinor	Minor version of the Transport Layer of the device.
DeviceTLVersionSubMinor	Sub minor version of the Transport Layer of the device.
DeviceGenCPVersionMajor	Major version of the GenCP protocol supported by the device.
DeviceGenCPVersionMinor	Minor version of the GenCP protocol supported by the device.
DeviceMaxThroughput	Maximum bandwidth of the data that can be streamed out of the device. This can be used to estimate if the connection can sustain transfer of free-running images from the camera at its maximum speed.
DeviceLinkSelector	Selects which Link of the device to control.
DeviceLinkThroughputLimitMode	Controls if the DeviceLinkThroughputLimit is active. When disabled, lower level TL specific features are expected to control the throughput. When enabled, DeviceLinkThroughputLimit controls the overall throughput.
DeviceLinkThroughputLimit	Limits the maximum bandwidth of the data that will be streamed out by the device on the selected Link. If necessary, delays will be uniformly inserted between transport layer packets in order to control the peak bandwidth.
DeviceLinkCommandTimeout	Indicates the command timeout of the specified Link. This corresponds to the maximum response time of the device for a command sent on that link.

Name	Description
DeviceCharacterSet	Character set used by the strings of the device's bootstrap registers.
DeviceReset	Resets the device to its power up state.
DeviceRegistersStreamingStart	Prepare the device for registers streaming without checking for consistency.
DeviceRegistersStreamingEnd	Announce the end of registers streaming. This will do a register set validation for consistency and activate it.
DeviceTemperatureSelector	Selects the location within the device, where the temperature will be measured.
DeviceTemperature	Device temperature in degrees Celsius (C). It is measured at the location selected by DeviceTemperatureSelector.
TimestampLatch	Latches the current timestamp counter into TimestampLatchValue.
TimestampLatchValue	Returns the latched value of the timestamp counter.
DeviceClockSelector	Selects the clock frequency to access from the device.
DeviceClockFrequency	Returns the frequency of the selected Clock.
DeviceUserMemory	Read/Write the user data from/to the non-volatile memory.
DeviceSleepMode	Selects the camera sleep mode or operating mode. The image could not acquire when camera operating with sleep mode.

9.18.2 ImageFormatControl

Name	Description
SensorWidth	Effective width of the sensor in pixels.
SensorHeight	Effective height of the sensor in pixels.
SensorShutterMode	Sets the shutter mode of the device.
WidthMax	Maximum width of the image (in pixels). The dimension is calculated after horizontal binning, decimation or any other function changing the horizontal dimension of the image.
HeightMax	Maximum height of the image (in pixels). This dimension is calculated after vertical binning, decimation or any other function changing the vertical dimension of the image.
DecimationHorizontal	Horizontal sub-sampling of the image. This reduces the horizontal resolution (width) of the image by the specified horizontal decimation factor.
DecimationVertical	Vertical sub-sampling of the image. This reduces the vertical resolution (height) of the image by the specified vertical decimation factor.
RegionSelector	Selects the Region of interest to control. The RegionSelector feature allows devices that are able to extract multiple regions out of an image, to configure the features of those individual regions independently.
ImageComponentSelector	Selects a component to activate data streaming from.
ImageComponentEnable	Controls if the selected component streaming is active.
Width	Width of the image provided by the device (in pixels).
Height	Height of the image provided by the device (in pixels).
OffsetX	Horizontal offset from the origin to the region of interest (in pixels).
OffsetY	Vertical offset from the origin to the region of interest (in pixels).
PixelFormat	Format of the pixels provided by the device. It represents all the information provided by PixelCoding, PixelSize, PixelColorFilter combined in a single feature.
PixelFormatInfoSelector	Select the pixel format for which the information will be returned.
PixelFormatInfoID	Returns the value used by the streaming channels to identify the selected pixel format.
PixelSize	Total size in bits of a pixel of the image.
PixelColorFilter	Type of color filter that is applied to the image.
ReverseX	This feature is used to flip horizontally the image sent by the device. The AOI is applied after the flipping.
ReverseY	This feature is used to flip vertically the image sent by the device. The AOI is applied after the flipping.
MultiROIsInMultiPayloads	MultiROIs In MultiPayloads.

9.18.3 AcquisitionControl

Name	Description
AcquisitionMode	Sets the acquisition mode of the device. It defines mainly the number of frames to capture during an acquisition and the way the acquisition stops.
AcquisitionStart	Starts the Acquisition of the device. The number of frames captured is specified by AcquisitionMode.
AcquisitionStop	Stops the Acquisition of the device at the end of the current Frame. It is mainly used when AcquisitionMode is Continuous but can be used in any acquisition mode.
AcquisitionArm	Arms the device before an AcquisitionStart command. This optional command validates all the current features for consistency and prepares the device for a fast start of the Acquisition.
AcquisitionBurstFrameCount	Number of frames to acquire for each FrameBurstStart trigger.
AcquisitionFrameRate	Controls the acquisition rate (in Hertz) at which the frames are captured.
TriggerSelector	Selects the type of trigger to configure.
TriggerMode	Controls if the selected trigger is active.
TriggerSoftware	Generates an internal trigger. TriggerSource must be set to Software.
TriggerSource	Specifies the internal signal or physical input Line to use as the trigger source. The selected trigger must have its TriggerMode set to On.
TriggerDelay	Specifies the delay in microseconds (us) to apply after the trigger reception before activating it.
ExposureMode	Sets the operation mode of the Exposure (or shutter).
ExposureTimeSelector	Selects which exposure time is controlled by the ExposureTime feature. This allows for independent control over the exposure components.
ExposureTime	Sets the Exposure time when ExposureMode is Timed and ExposureAuto is Off. This controls the duration where the photosensitive cells are exposed to light.
ExposureAuto	Sets the automatic exposure mode when ExposureMode is Timed. The exact algorithm used to implement this control is device-specific.
ExposureAutoLimitMax	Determine the upper limit of exposure time when ExposureAuto is set to Continuous.
ExposureAutoLimitMin	Determine the lower limit of exposure time when ExposureAuto is set to Continuous.

9.18.4 TransportLayerControl

Name	Description
PayloadSize	Provides the number of bytes transferred for each image or chunk on the stream channel. This includes any end-of-line, end-of-frame statistics or other stamp data. This is the total size of data payload for a data block.

9.18.5 DigitalIOControl

Name	Description
LineSelector	Selects the physical line (or pin) of the external device connector to configure.
LineMode	Controls if the physical Line is used to Input or Output a signal.
LineInverter	Controls the inversion of the signal of the selected input or output Line.
LineStatus	Returns the current status of the selected input or output Line.
LineSource	Selects which internal acquisition or I/O source signal to output on the selected Line. LineMode must be Output.
UserOutputSelector	Selects which bit of the User Output register will be set by UserOutputValue.
UserOutputValue	Sets the value of the bit selected by UserOutputSelector.
StrobeOutDelay	Delay of StrobeOut signal when LineSource is set to StrobeOut(us).
StrobeOutOnTime	Duration of StrobeOut signal when LineSource is set to StrobeOut(us).
TriggerOutDelay	Delay of TriggerOut signal when LineSource is set to TriggerOut(us).
TriggerOutOnTime	Duration of TriggerOut signal when LineSource is set to TriggerOut(us).
LineDeviceResetMode	Sets the Line device reset mode.
LineDebounceTime	Sets the value of the input line debouncer time.

9.18.6 CounterAndTimerControl

Name	Description
CounterSelector	Selects which Counter to configure.
CounterEventSource	Select the events that will be the source to increment the Counter.
CounterEventActivation	Selects the Activation mode Event Source signal.
CounterResetSource	Selects the signals that will be the source to reset the Counter.
CounterResetActivation	Selects the Activation mode of the Counter Reset Source signal.
CounterReset	Does a software reset of the selected Counter and starts it. The counter starts counting events immediately after the reset unless a Counter trigger is active. CounterReset can be used to reset the Counter independently from the CounterResetSource. To disable the counter temporarily, set CounterEventSource to Off.
CounterValue	Reads or writes the current value of the selected Counter.
CounterValueAtReset	Reads the value of the selected Counter when it was reset by a trigger or by an explicit CounterReset command.
CounterDuration	Sets the duration (or number of events) before the CounterEnd event is generated.
CounterStatus	Returns the current status of the Counter.
CounterTriggerSource	Selects the source to start the Counter.
CounterTriggerActivation	Selects the activation mode of the trigger to start the Counter.

9.18.7 EventControl

Name	Description
EventSelector	Selects which Event to signal to the host application.
EventNotification	Activate or deactivate the notification to the host application of the occurrence of the selected Event.

9.18.8 EventExposureEndData

Name	Description
EventExposureEnd	Returns the unique identifier of the ExposureEnd type of Event. This feature can be used to register a callback function to be notified of the event occurrence. Its value uniquely identifies the type of event that will be received.
EventExposureEndTimestamp	Returns the Timestamp of the ExposureEnd Event. It can be used to determine precisely when the event occurred.

9.18.9 EventExposureStartData

Name	Description
EventExposureStart	Returns the unique Identifier of the Exposure Start type of Event.
EventExposureStartTimestamp	Returns the Timestamp of the Exposure Start Event.

9.18.10 EventTestData

Name	Description
EventTest	Returns the unique identifier of the Test type of Event. This feature can be used to register a callback function to be notified of the event occurrence. Its value uniquely identifies the type of event that will be received.
EventTestTimestamp	Returns the timestamp of the Test event.

9.18.11 AnalogControl

Name	Description
GainSelector	Selects which Gain is controlled by the various Gain features.
Gain	Controls the selected gain as an absolute physical value. This is an amplification factor applied to the video signal.
GainAuto	Sets the automatic gain control (AGC) mode. The exact algorithm used to implement AGC is device-specific.
GainAutoLimitMax	Determine the upper limit of gain when GainAuto is set to Continuous.
GainAutoLimitMin	Determine the lower limit of gain when GainAuto is set to Continuous.
AutoLightTarget	Determine the brightness target for GainAuto.
BlackLevelSelector	Selects which Black Level is controlled by the various Black Level features.
BlackLevel	Controls the black level as an absolute physical value. This represents a DC offset applied to the video signal.
BalanceRatioSelector	Selects which Balance ratio to control.
BalanceRatio	Controls ratio of the selected color component to a reference color component. It is used for white balancing.
BalanceWhiteAuto	Controls the mode for automatic white balancing between the color channels. The white balancing ratios are automatically adjusted.

9.18.12 LUTControl

Name	Description
PixelCorrectionAllEnabled	Enable pixel correction for all pixels.
PixelCorrectionIndex	Determine index of targeted pixel for pixel correction.
PixelCorrectionEnabled	Determine if targeted pixel is enabled for pixel correction.
PixelCorrectionX	Determine x-coordinate of targeted pixel for pixel correction.
PixelCorrectionY	Determine y-coordinate of targeted pixel for pixel correction.

9.18.13 UserSetControl

Name	Description
UserSetSelector	Selects the feature User Set to load, save or configure.
UserSetLoad	Loads the User Set specified by UserSetSelector to the device and makes it active.
UserSetSave	Save the User Set specified by UserSetSelector to the non-volatile memory of the device.
UserSetDefault	Selects the feature User Set to load and make active by default when the device is reset.

9.18.14 ChunkDataControl

Name	Description
ChunkModeActive	Activates the inclusion of Chunk data in the payload of the image.
ChunkSelector	Selects which Chunk to enable or control.
ChunkEnable	Enables the inclusion of the selected Chunk data in the payload of the image.
ChunkCounterSelector	Selects which counter to retrieve data from.
ChunkCounterValue	Returns the value of the selected Chunk counter at the time of the FrameStart event.
ChunkGainSelector	Selects which Gain to return.
ChunkGain	Returns the gain used to capture the image.
ChunkBlackLevelSelector	Selects which Black Level to return.
ChunkBlackLevel	Returns the black level used to capture the image included in the payload.
ChunkExposureTimeSelector	Selects which exposure time is read by the ChunkExposureTime feature.
ChunkExposureTime	Returns the exposure time used to capture the image.
ChunkGamma	Returns the gamma used to capture the image.

9.18.15 TestControl

Name	Description
TestPendingAck	Tests the device's pending acknowledge feature. When this feature is written, the device waits a time period corresponding to the value of TestPendingAck before acknowledging the write.
TestEventGenerate	Generates a Test Event.
TriggerEventTest	This register is used to control the generation of test events.

9.18.16 LensConnect Control

Name	Description
LensConnectProtocolVersion	This indicates the version of the protocol conformed. The protocol version corresponds to the specification version.
LensConnectFirmwareVersion	This indicates the version of the software (firmware) for controlling that is embedded in the lens.
LensConnectLensModelName	This indicates the lens model/manufacturer name in 32 ASCII. The first 24 bytes indicate the lens model, and the remaining 8 bytes indicate the manufacturer's name.
LensConnectLensRevision	This indicates the lens revision.
LensConnectLensAddress	This indicates the feature of the lens in bits. When the bit is 1, the feature is equipped.
LensConnectStatus1	This indicates the state of the device, etc., equipped on the lens in bits. The value fluctuates depending on the state.
LensConnectStatus2	This indicates the state of the device, etc., equipped on the lens in bits. The value fluctuates depending on the state.
LensConnectTemperatureValue	This indicates the value measured by the temperature measuring device equipped on the lens.
LensConnectTemperatureMin	This indicates the minimum operating temperature of the lens specification.
LensConnectTemperatureMax	This indicates the maximum operating temperature of the lens specification.
LensConnectUserArea	This is the area that can be used by a user.
LensConnectZoomPositionValue	Change the Zoom address for target position
LensConnectFocusPositionValue	Change the Focus address for target position
LensConnectIrisPositionValue	Change the Iris address for target position
LensConnectOpticalFilterPositionValue	Change the Optical Filter address for target position
LensConnectZoomInitialize	Initializing of Zoom (Go to the P/I position)
LensConnectFocusInitialize	Initializing of Focus (Go to the P/I position)
LensConnectIrisInitialize	Initializing of Iris (Go to the P/I position)
LensConnectOpticalFilterInitialize	Initializing of OpticalFilter (Go to the P/I position)
LensConnectZoomCountValue	This indicates the number of motor operations.
LensConnectZoomCountMax	This indicates the maximum value of the number of operations in the specification. The lens operation will not be limited by this value.
LensConnectFocusCountValue	This indicates the number of motor operations.
LensConnectFocusCountMax	This indicates the maximum value of the number of operations in the specification. The lens operation will not be limited by this value.
LensConnectIrisCountValue	This indicates the number of motor operations.
LensConnectIrisCountMax	This indicates the maximum value of the number of operations in the specification. The lens operation will not be limited by this value.
LensConnectOpticalFilterCountValue	This indicates the number of motor operations.
LensConnectOpticalFilterCountMax	This indicates the maximum value of the number of operations in the specification. The lens operation will not be limited by this value.

10 Revision History

Rev	Date	Changes	Note
00	2025/04/11	● New Document	

Note: Product specifications would be changed without notification.

Aegis Electronic Group
www.aegiselect.com

USB3 Vision is trademark of A3 (Association for Advancing Automation).

GenICam is trademark of EMVA.

Other company names and product names in this document are trademarks of their respective owners.

Aegis Electronic Group
www.aegiselect.com

OMRON SENTECH CO., LTD.

19F, Ebina Prime Tower
9-50, Chuo 2 chome
Ebina-city, Kanagawa
243-0432 Japan
TEL +81-46-236-6660 FAX +81-46-236-6661
URL <http://www.sentech.co.jp/>