

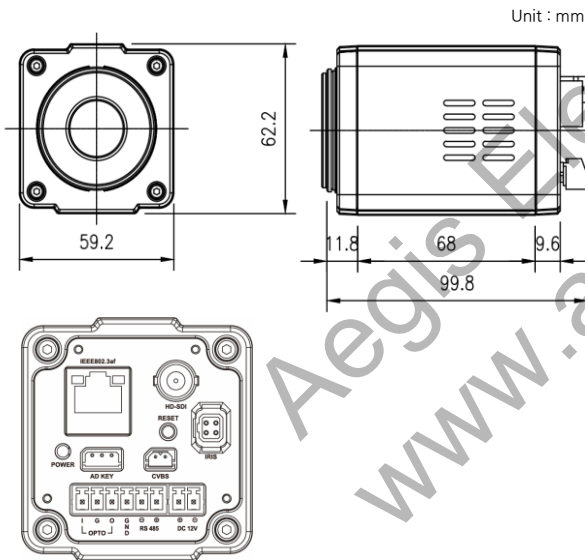

Features

- 1/1.8" Sony Global Shutter CMOS Sensor
- Full HD Video Output up to 1080p 60fps
- Camera setup by OSD Menu
- C/CS Mount Lens & DC Iris Lens applicable
- AD Key port for wired remote controller
- Remote control via RS-485
- Supports External trigger input and Strobe output
- Color Model : MB-HG15C, BW Model : MB-HG15M

Dimensions



MB-HG15	
CAMERA	
Image Sensor	1/1.8" Sony Global Shutter CMOS Sensor
Total Pixels	2064(H) x 1554(V) = 3.21M Pixels
Active Pixels	1920(H) x 1080(V) = 2.07M Pixels
Video Format	1080p@60/50fps, 1080p@30/25fps, 720p@60/50fps, 720p@30/25fps
Min. Illumination	COLOR MB-HG15C : 0.3 lux / DSS 0.075 lux BW MB-HG15C, MB-HG15M : 0.02 lux / DSS 0.005 lux
Shutter Mode	Global Shutter
S/N Ratio	more than 50dB(AGC off)
Video Output	NETWORK, HD-SDI, EX-SDI, CVBS
LENS	
Lens	DC / Manual
Lens Mount	C/CS-Mount
CAMERA FUNCTIONS	
Camera Title	ID / Title / Zoom Ratio / System Message
Day & Night	MB-HG15C : Day MB-HG15M : Night
BLC	Off / On
ACE	Off / Manual(0~11 steps)
DNR	Off / 2D / 3D / 2D+3D(Auto / Low / Middle / High)
Defog	Off / Manual(0~11 steps)
HLC	Off / On
Motion Detection	Off / On(4 positions)
Privacy Mask	Off / On(8 positions)
Digital Slow Shutter	Off / x2 / x3 / x4 / x5 / x6 / x7 / x8 / x9 / x10 / x12 / x15
Gain Control	Off / On
White Balance	Auto / One Push / Manual / Indoor / Outdoor
Shutter Speed	1/30(25) ~ 1/10,000 sec
E.Zoom	Off / On(x1 ~ x6)
Digital Flip	Off / H / V / H&V
NETWORK	
Ethernet	RJ-45(10/100BASE-T)
Video Compression	H.265, H.264, MJPEG
Resolution	1080p, 720p, 1024x576, 640x360, D1, 4CIF, VGA
Streaming Capability	Triple Streaming
IP	IPv4, IPv6
Protocol	TCP, IP, HTTP, DHCP, FTP, DNS, DDNS, NTP, ICMP, SNMP, SMTPE, UPnP, RTP, RTSP, ONVIF
Webpage Language	Korean, English
GENERAL	
Power Source	DC12V±10% / 802.3af PoE
Power Consumption	Max 550mA
Operating Temperature	-10°C ~ +50°C / 0% ~ 90% RH
Dimensions	59.2(W) x 62.2(H) x 99.8(D) mm
Weight	0.285kg

[Note] Product are divided into Color model and BW model.