

# CIS

CoaXPress I/F  
250M pixels CMOS RAW Camera

# VCC-250CXP1R

Product Specifications  
& Operational Manual

**CIS Corporation**

## Table of Contents

1.	Handling Precautions.....	1
1.1.	Camera Handling Precautions.....	1
1.2.	Restrictions on Applications.....	1
1.3.	Disclaimers (Exception Clause).....	1
2.	Product Outline.....	2
2.1.	Features.....	2
2.2.	Accessories.....	2
3.	Specifications.....	3
3.1.	General Specifications.....	3
3.2.	Input and Output Specifications.....	4
3.2.1	Trigger Input (12pins circular connector, No.11 pin).....	4
3.2.2	Trigger Output (12pins circular connector, No.7, 9, and 10 pin).....	4
3.3.	External Connector Pin Assignment.....	5
3.3.1	12pins Circular Connector HR10-10R-12PA(73) (HIROSE) or Equivalent.....	5
3.3.2	75Ω DIN Connector.....	5
3.3.3	LED Indicator.....	6
3.4.	Spectral Response.....	6
4.	Camera Functions.....	7
4.1.	Camera Interface.....	7
4.2.	Camera Information.....	7
4.3.	LED Operational Mode.....	7
4.4.	Partial Scan (ROI).....	8
4.5.	Pixel Format.....	8
4.6.	Cursor Indication.....	8
4.7.	Test Pattern Indication.....	9
4.8.	Trigger Mode.....	9
4.8.1	Internal Sync. Mode (Free Run Mode).....	10
4.8.2	External Sync Mode.....	11
4.9.	Exposure Time.....	12
4.10.	Gain.....	12
4.11.	Black Level Adjustment.....	13
4.12.	OB Clamp Adjustment.....	13
4.13.	Shading Correction.....	13
4.14.	Gamma Correction.....	14
4.15.	Defective Pixel Correction.....	15
4.16.	Noise Filter.....	15
4.17.	Strobe Pulse Control.....	16
4.18.	Device Temperature Control Function.....	17
4.19.	Link Speed and Link Count.....	17
4.20.	How to Save and Initialize Settings.....	17
4.21.	White Balance.....	18
5.	Factory Settings.....	19
6.	Dimensions.....	20
6.1.	Camera Dimensions.....	20
6.2.	Optical Axis Accuracy.....	21
7.	Case for Indemnity (Limited Warranty).....	22
7.1.	Product Warranty.....	22
7.2.	CMOS Defective Pixels.....	22

7.3. Product Support ..... 22

Aegis Electronic Group  
www.aegiselect.com

## 1. Handling Precautions

### 1.1. Camera Handling Precautions

- Do not use or store camera in dusty or humid places.
- Do not apply excessive force, vibration, or static electricity that could damage camera. Please handle camera with care.
- Do not shoot direct images that are extremely bright (e.g., strong light source, sun, etc.). When extremely strong light source is shot, smear or blooming may occur. Put the lens cap on when camera is not in use.
- Follow the instructions in [Chapter 3.3., "External Connector Pin Assignment"](#) for connecting camera. Improper connection may cause damages not only to the camera but also to the connected devices.
- Confirm mutual ground potential carefully before connecting camera to monitors or computers. Any AC leak from the connected devices may cause damages or destroy the camera.
- Do not apply excessive voltage. (Use only the specified voltage.) Unstable or improper power supply voltage may cause damages or malfunction of the camera.
- Voltage ripple of camera power DC+12V±10% must be within ±50mV. Improper power supply voltage may cause noises on video signals.
- Rise time of camera power supply voltage must be less than +10.8V, Max. 60ms. Please avoid noises like chattering.
- Our warranty does not apply to damages or defects caused by irregular and/or abnormal use of the product.

Our warranty does not apply to damages or defects caused by neglecting the instructions and precautions explained in this manual.

### 1.2. Restrictions on Applications

- The camera must not be used for any nuclear equipment or aerospace equipment with which mechanical failure or malfunction could result in serious bodily injury or loss of human life.
- The camera must not be used under conditions or environments other than those specified in this manual.

### 1.3. Disclaimers (Exception Clause)

CIS should not be liable for any damages or losses if;

- damages or losses are caused by earthquake, lightning strike, fire, flood, or other acts of God.
- damages or losses are caused by deliberate or accidental misuse by user, or failure to observe information and instructions explained in this manual.
- damages or losses are caused by repair or modification conducted by user or any unauthorized party.

## 2. Product Outline

VCC-250CXP1R is a CoaXPress interface, high resolution, color camera using an APS-H" rolling shutter CMOS image sensor. 100mm (H) × 100mm (W) × 90.6mm (D) camera size with 246M pixels resolution. Complies with CoaXPress Version 1.1.1 and transfers data up to 40m with CXP-6. Must have function ready for Machine Vision applications such as trigger shutter, ROI, defective pixel correction, Gain, shading correction, black level adjustment, white balance, noise filter function, and strobe-pulse control function. Suitable for various Machine Vision inspection systems, medical imaging, archives, and life science imaging systems.

### 2.1. Features

- Rolling shutter type CMOS sensor
- Complies with CoaXPress CXP-6
- Supports 4 lanes
- Supports PoCXP
- Maximum cable length: Approx. 40m with CXP-6
- ROI
- Exposure setting, Gain setting
- External trigger mode
- Complies to GenICam
- M48 lens mount

### 2.2. Accessories

- Optional accessories
  - ◆ M48 to F lens mount conversion ring
  - ◆ M48 to C lens mount conversion ring

## 3. Specifications

## 3.1. General Specifications

Electrical Specifications			
Image sensor	Sensor type	APS-H, rolling shutter type CMOS sensor	
	Effective pixels	19568(H) × 12588(V)	
	Unit cell size	1.5μm(H) × 1.5μm(V)	
Interface		Complies with CoaXPress Ver. 1.1.1., CXP6	
Video output frequency	Pixel clock frequency	1152MHz	
Video output format		Bayer8 / Bayer10 / Bayer12	
Frame rate	CXP6_X4 8/10/12bit	5.00fps/5.00fps/3.17fps	
Resolution		19568(H) × 12588(V)	
Video signals	White clip level	FFh	with Bayer8
	Set up level	0h	with Bayer8, with factory setting
	Dark shading	0~1h(H), 0~1h(V)	with Bayer8, with factory setting
Sensitivity		F4 400lx (Bayer12, shutter speed 100000μs, Gain x1)	
Minimum illumination		F2.6 59.4lx (Bayer12, shutter speed 100000μs, Gain x8, level=50%)	
Gain variable range		x1~x8 (0dB~18dB)	
Shutter speed		200[μs]~15000000[μs]	
Gamma correction		Valid (Gamma: 0.3~3.0)	
Trigger mode		Free run mode (Camera internal trigger) External trigger sync. mode (Host, external terminal)	
Partial scan		Manual ROI	
Power requirements		12pins circular connector (+10.8V~26.2V) or PoCXP (+18.5V~26V)	
Power consumption		Max. 12.2W (CXP6_X4) with free run	
Mechanical Specifications			
Dimensions		H:100mm W:100mm D:95.6mm excluding projection.	
Weight		830g	
Lens mount		M48 mount	
Environmental Specifications			
Safety/Quality Standards		CE: EMC: 2014/30/EU Emission: EN61000-6-4:2007+A1:2011 Immunity: EN61000-6-2:2019 RoHS: 2011/65/EU (EU)2015/863	
Durability	Vibration	Acceleration	: 98m/s <sup>2</sup> (10G)
		Frequency	: 20 ~ 200Hz
		Direction	: X, Y, and Z 3 directions
		Testing time	: 120min for each direction
	Shock	No malfunction with 980m/s <sup>2</sup> (100) G for ±X, ±Y, and ±Z, 6 directions without packaging.	
Operational temperature		0 ~ +45°C Humidity: 20 ~ 80%RH with no condensation.	
Storage temperature		-25 ~ +60°C Humidity: 20 ~ 80%RH with no condensation.	

### 3.2. Input and Output Specifications

#### 3.2.1 Trigger Input (12pins circular connector, No.11 pin)

- 5.0V, 3.3V CMOS level/TTL level
- Input voltage Low: 0~0.5Vdc , High: 2.0~5.0Vdc
- To use this terminal, set Trigger Source of AcquisitionControl to Line 0.

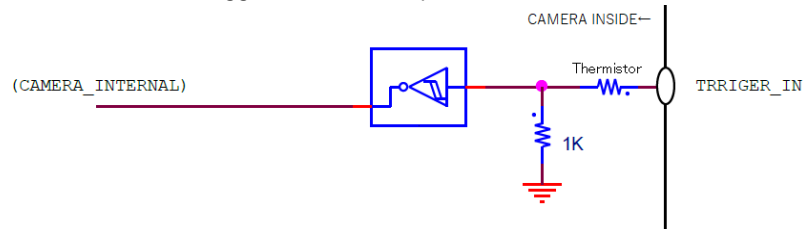

#### 3.2.2 Trigger Output (12pins circular connector, No.7, 9, and 10 pin)

- 5.0V CMOS logic level output
- Output voltage Low: 0~0.3Vdc , High: 4.5~5.0Vdc
- Output current  $\pm 8\text{mA}$  (max.)

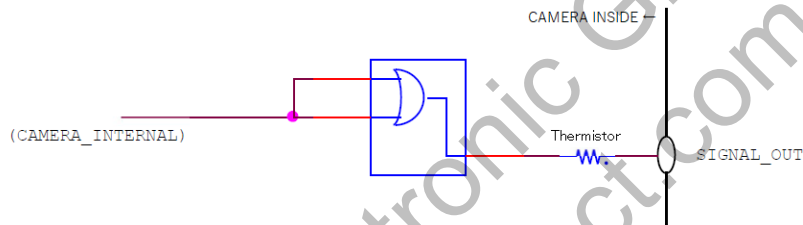

\*Thermistor Murata Manufacturing Co. PRG15BC330MM1RC

### 3.3. External Connector Pin Assignment

#### 3.3.1 12pins Circular Connector HR10-10R-12PA(73) (HIROSE) or Equivalent

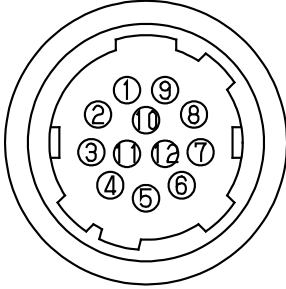

Pin	Signal Name	Explanation
1	GND	GND
2	Power	External power input +12V~+24V±10%
3	NC	
4	NC	
5	GND	GND
6	NC	
7	FVAL_OUT	Frame readout signals output
8	GND	GND
9	STRB_OUT	Strobe signals output
10	LinkTrigger_OUT	External trigger signals output from Host Device (LinkTrigger0)
11	TRIGGER_IN	External trigger input (Line0)
12	GND	GND

※NC=Non-Connection. Do not connect anything to the terminal.

※LinkTrigger\_OUT signal is to monitor the external trigger signals from host device.

※Recommended value for power voltage

1. Power voltage: E[V]
2. Cable length: l[m]
3. Resistance value of cable per 1m: r[Ω/m]

Formula to calculate output voltage of external power:

$$E[V]=12[V]+r[\Omega/m]\times l[m]\times 1.1[A]$$

Please supply E[V] within the range of power voltage specifications from the external power to the camera.

※To avoid malfunction of the camera, please stop power supply from CoaXPress cable when supply the power from the circular connector for external power supply.

※Make sure to use power supply cable less than 30m.

#### 3.3.2 75Ω DIN Connector

- CoaXPress video output signals.
- No.1 pin is for PoCXP.



(COAX Connectors)

※Please confirm the specifications (current that can be supplied) of frame grabber board when supply power by PoCXP. Please use COAX cable of OD 4mm or more (cable core: copper single wire 23AWG[0.57Φ]), and the cable length is within 8.0m.

3.3.3 LED Indicator

□ With LED indicator ON, lighting patterns show the camera status by its way of lighting.

OFF	No power supply.
Green/Orange Fast Blinking [12.5Hz]	Disconnection of 4 cable lines.
Green Lighting	Completion of connection between device and host.
Green Fast Blinking [12.5Hz]	Transmitting video data.
Orange Slow Blinking [1Hz]	Waiting for a trigger input.
Red Fast Blinking [12.5Hz]	Image transmission error or inappropriate trigger detected. [Error]

※Error will be indicated if detected illegal triggers while using external trigger sync mode.

※Error indication will be canceled when stopped grabbing.

3.4. Spectral Response

※ Excludes characteristics of lens, IR cut filter, and light source.

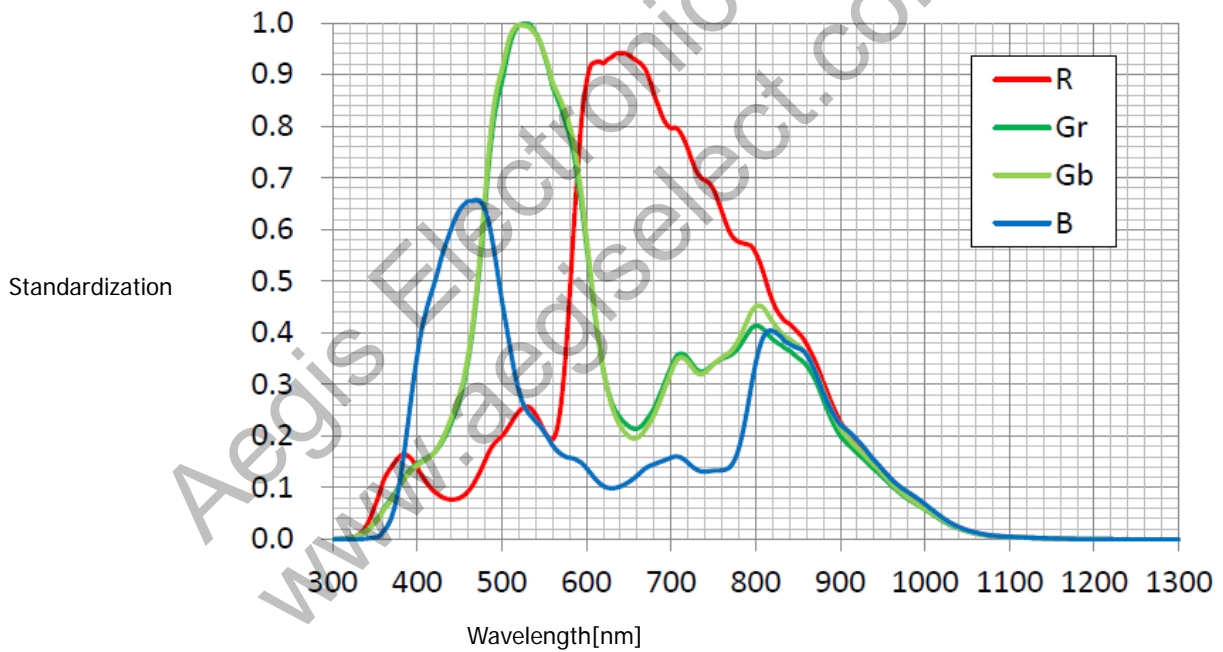

The above characteristics are typical values and are not guaranteed values.

## 4. Camera Functions

## 4.1. Camera Interface

- Complies with CoaXPress interface standard.

## 4.2. Camera Information

- Indication of camera information.

DeviceControl	
DeviceModelName	ReadOnly
DeviceVersion	ReadOnly
DeviceFirmwareVersion	ReadOnly
DeviceSerialNumber	ReadOnly

- DeviceModelName : Model name of the camera
- DeviceVersion : Circuit version
- DeviceFirmwareVersion : Firmware version
- DeviceSerialNumber : Serial number of the camera

- Set a letter string as user ID with up to 16 characters including terminal NUL letter (¥0). Execute "UserSetSave" to save the letter string to volatile memory in the camera. Execute "UserSetDefault" to restore to factory setting.

DeviceControl	
DeviceUserID	Manual

## 4.3. LED Operational Mode

- This is to change operational mode of LED at the rear of camera. For information on lighting patterns, refer to [Section 3.3.3. LED Indicator](#).

DeviceControl	
DeviceIndicatorMode	Active ErrorStatus Inactive

- Active : Indication of communication status of CoaXPress.
- ErrorStatus : OFF with normal operation. Lights only with video transmission error or inappropriate trigger input.
- Inactive : ALL LED OFF.

## 4.4. Partial Scan (ROI)

- This is to increase frame rate by cutting and reducing readout area.

ImageFormatControl	
RegionMode	Off/On
Width	1920~19568
Height	1080~12588
OffsetX	0~(19567-Width)
OffsetY	0~(12587-Height)

- ROI

- Turn "RegionMode" off to change "Width", "Height", "OffsetX", and "OffsetY" settings.  
: Turn "RegionMode" on to enable the values of "Width", "Height", "OffsetX", and "OffsetY".  
Make sure to turn on "RegionMode" when obtain images.
- With Width, designate the size of ROI for X direction per 8 pixels.
- With Height, designate the size of ROI for Y direction per 2 pixels.
- With OffsetX, designate offset of ROI for X direction per 8 pixels.
- With OffsetY, designate offset of ROI for Y direction per 2 pixels.

## [Note]

- Defective pixel correction is invalid with ROI function. Turn off "DefectPixelCorrectionEnable" to change Width, Height, OffsetX, and OffsetY of ROI.

## 4.5. Pixel Format

ImageFormatControl	
PixelFormat	BayerRG8 BayerRG10 BayerRG12

- BayerRG8 : Bayer 8bit
- BayerRG10 : Bayer 10bit
- BayerRG12 : Bayer 12bit

## 4.6. Cursor Indication

- This is to show cursor on your display screen.

ImageFormatControl	
CursorPattern	On/Off
CursorOffsetX	X coordinate
CursorOffsetY	Y coordinate
CursorColor	White/Black

- CursorPattern : Cursor indication On/Off.
- CursorOffsetX : To designate X coordinate of vertical cursor.
- CursorOffsetY : To designate Y coordinate of horizontal cursor.
- CursorColor : To select the color of cursor (black or white with Bayer).

## [Note]

- With reduced display screen, cursor may not appear.
- Displaying cursor and "ColorBar" and "ColorBarMoving" of test pattern indication are mutually exclusive.
- When ROI, input coordinate position to CursorOffsetX and CursorOffsetY of full scale.

## 4.7. Test Pattern Indication

- This is to display test pattern from camera. This is useful to check if your system is operating properly.

ImageFormatControl	
TestPattern	Off ColorBar ColorBarMoving

[Note] Displaying test pattern and cursor are mutually exclusive.

## 4.8. Trigger Mode

Acquisition Control	
TriggerSelector	AcquisitionStart FrameStart
TriggerMode	Off/On
TriggerActivation	RisingEdge FallingEdge
TriggerSource	LinkTrigger0 Line0
TriggerSoftware	Execute

- TriggerSelector

This is to select how to start capturing video out of the followings.

- AcquisitionStart : Free run mode (Internal sync. mode)
- FrameStart : External sync. mode

- TriggerMode

This is to select trigger valid/invalid with external sync mode.

- Off : Trigger invalid
- On : Trigger valid

- TriggerActivation

This is to select trigger polarity out of the followings.

Valid when TriggerSelector mode is FrameStart.

- RisingEdge : Rising edge (External sync mode)
- FallingEdge : Falling edge (External sync mode)

- TriggerSource

This is to select where to send external trigger.

- LinkTrigger0 : External trigger input from CoaXPress host device.  
Please refer to specification manuals of host device such as frame grabber board to know how to generate triggers.
- Line0 : External trigger input from 12pins circular connector.

※FallingEdge of TriggerActivation is not recommended while selecting LinkTrigger0.

- TriggerSoftware: Software trigger

Camera generates a trigger to capture one frame image by executing this command.

Valid when TriggerSelector mode is FrameStart.

※Please set TriggerActivation to RisingEdge.

4.8.1 Internal Sync. Mode (Free Run Mode)

- With this mode, camera continuously outputs images.
- Set TriggerSelector to AcquisitionStart.

With Standard Exposure

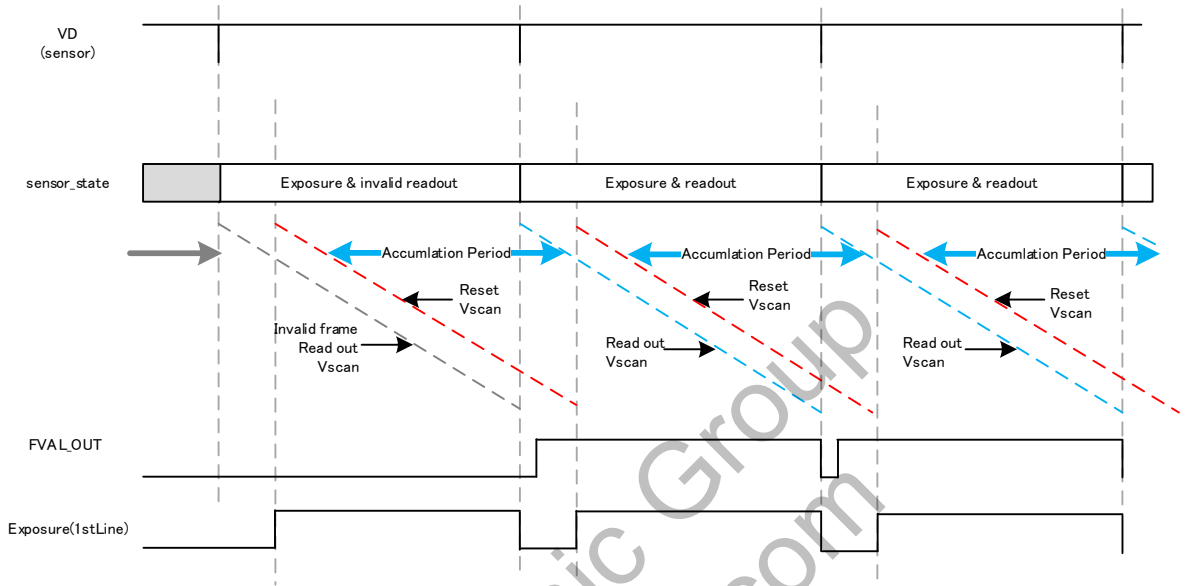

With long time exposure (Exposure time is longer than 1 frame)

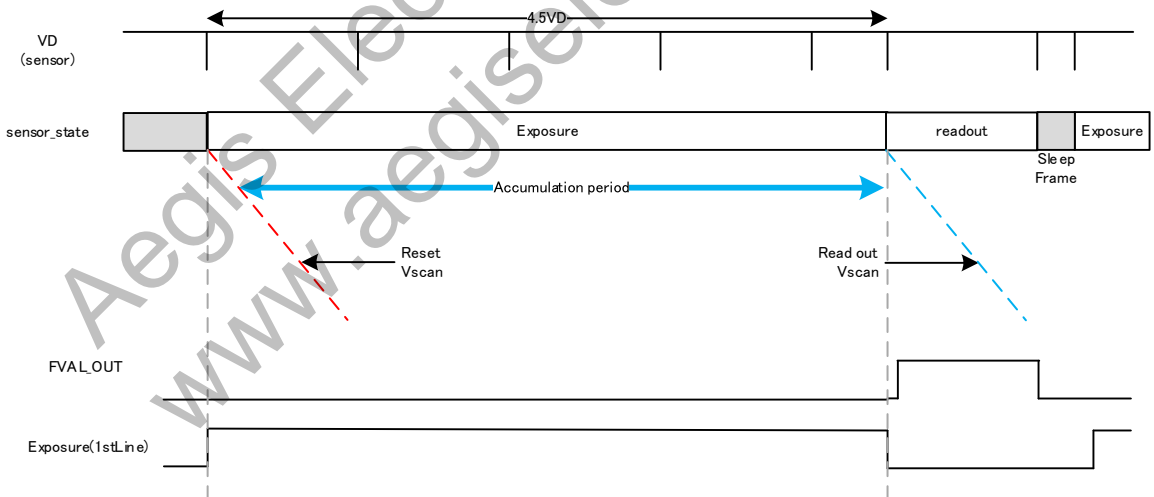

※Please refer to the chart above when exposure time is 4.5 frame. Accumulation and Readout cannot be overlapped with long time exposure.

4.8.2 External Sync Mode

- This is a mode to capture images with preferred timings by inputting external trigger signals.
- Set "TriggerSelector" to "FrameStart".
- With a trigger signal input, camera exposes for a period set by "ExposureTime".
- Set "TriggerActivation" to "RisingEdge" or "FallingEdge".
- Trigger cycle must be longer than (frame for exposure time + frame for readout + 3 lines).
- Trigger operation is CLK sync H-V sync reset.
- Trigger pulse width to input must be longer than 1µs.
- Due to physical characteristics of image sensor, there are some delays between the actual exposure start and trigger input. With higher shutter speed settings, time from trigger input to actual exposure start takes longer.

With standard exposure

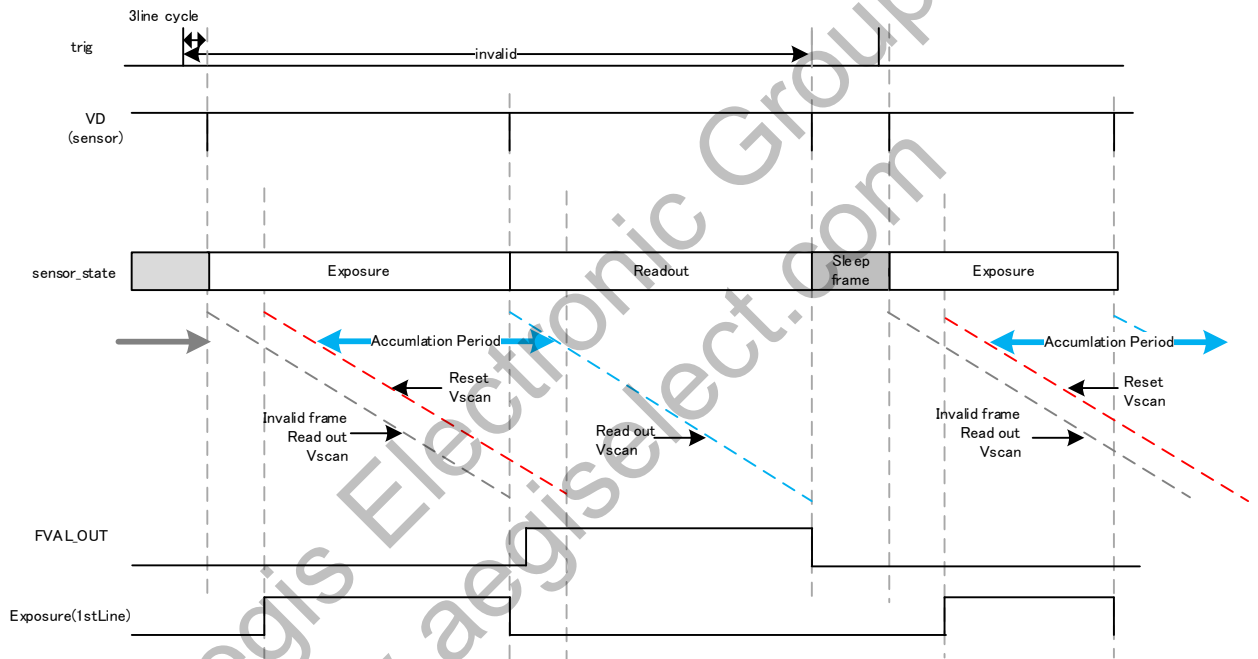

**With long time exposure (Exposure time is longer than 1 frame)**

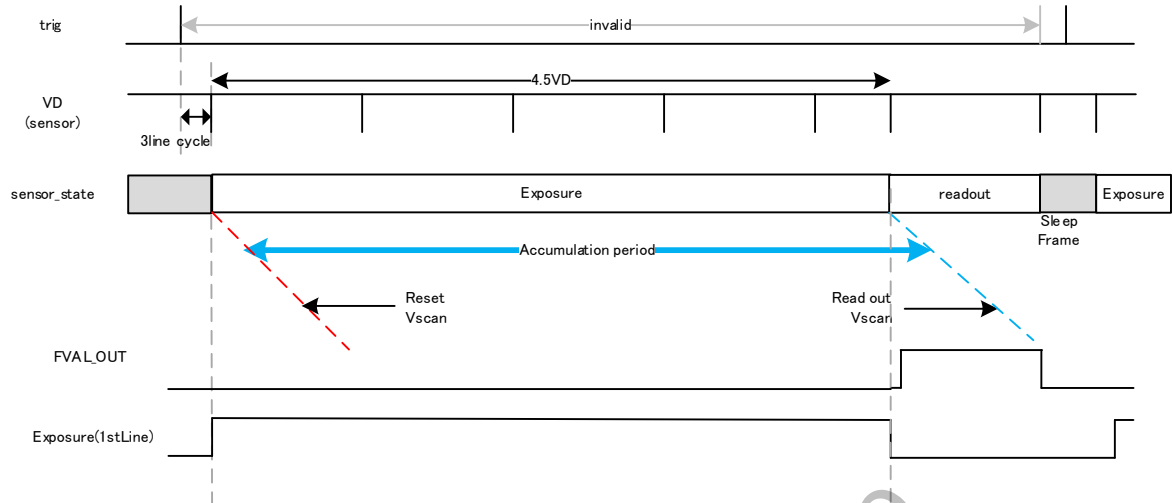

4.9. Exposure Time

Acquisition Control	
ExposureTime (μs)	200~15000000

ExposureTime

Set with multiples of 15.716μs with BayerRG8 and BayerRG10, and set with multiples of 24.79μs with BayerRG12.

- ※ When setting is other than multiples of 15.716μs or 24.79μs, the nearest value will be set.
- ※ When changed from long time exposure to standard exposure, an image for 1 frame during that period (from long time exposure starts to changed exposure time) may be shown.
- ※ At the transition between standard exposure and long time exposure, there might be slight misalignment of output level continuity.

4.10. Gain

AnalogControl	
Gain	1.0~8.0

- Gain : 1 x1 to x8 preferred gain settings

[Note]

Gain setting range is up to +8 times. However, with high gain settings, noise will increase.

## 4.11. Black Level Adjustment

- This is to adjust black level at the latter part of camera image processing.

AnalogControl	
BlackLevel	0~16

BlackLevel	8bit	10bit	12bit
0	0	0	0
1	1	4	16
2	2	8	32
3	3	12	48
4	4	16	64
5	5	20	80
6	6	24	96
7	7	28	112
8	8	32	128
9	9	36	144
10	10	40	160
11	11	44	176
12	12	48	192
13	13	52	208
14	14	56	224
15	15	60	240
16	16	64	256

※ This function is valid only for + direction.

## 4.12. OB Clamp Adjustment

- This is to adjust OB clamp at the former part of camera image processing.

OpticalBlackControl	
OBClampOffset	-1024~1023

- OBClampOffset : Offset value of OB clamp

\* This value is 12bit converted values. When PixelFormat is Bayer12, setting -1 will also decrease the output level by -1. The saturation level will remain at 4095, but this is not guaranteed as it depends on the camera settings. When PixelFormat is Bayer10, setting -4 will decrease the output level by -1(10bit range). When PixelFormat is Bayer8, setting -16 will decrease the output level by -1(8bit range).

## 4.13. Shading Correction

- This is to correct the drop in the amount of peripheral light caused by lens and others.

AnalogControl	
ShadingCorrection	True/False
DetectShading	Execute
ShadingCorrectionDataSelector	0~3
ShadingDataIndex	0~329
ShadingDataValue	0x0~0x7fff
ShadingDataLoad	Execute
ShadingDataSave	Execute

- ShadingCorrection

Turn ShadingCorrection "True" to start shading correction according to correction data prepared by shading detection.

Before shading correction

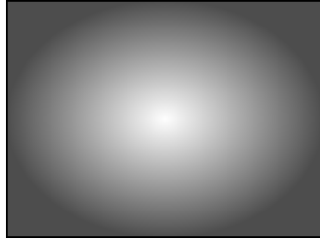

After shading correction



- Shading correction data must be obtained with DetectShading prior to shading correction.
- DetectShading  
Shoot an object with stable brightness such as pattern box, to full screen. Execute DetectShading to automatically calculate correction data.

[Note]

- Make sure that partial scan mode (ROI) is full scale when set correction data. (Set image size to 19568x12588 to execute.)
- Detect shading only when camera is in operation. Shading detection data may not be updated if the camera operation is not completed within 1 second after executed DetectShading during long time exposure and external sync mode. In that case, execute DetectShading again when camera is in operation. (Proper shading correction data cannot be obtained when the camera does not output anything.)
- ShadingCorrectionDataSelector  
Shading correction data are selectable out of 4 types. Data (0~3) selected here becomes the correction data to be controlled by each function.
- ShadingDataIndex : Shading correction data index number  
There are 330 indexes for one shading correction data. Set input value in the range of 0~329.
- ShadingDataValue : Shading correction data value  
※ Shading correction data value is not eligible to save with UserSetSave.
- ShadingDataLoad : Shading correction data readout  
Only the number selected with ShadingCorrectionDataSelector will be readout from camera non-volatile memory.  
※ When start-up the camera, shading correction data selected with ShadingCorrectionDataSelector will be readout from camera non-volatile memory as well.
- ShadingDataSave : Save shading correction data  
Only the number selected with ShadingCorrectionDataSelector will be saved in camera non-volatile memory.

#### 4.14. Gamma Correction

- This is to correct gamma.

AnalogControl	
Gamma	0.3~3.0 gamma coefficients

Gamma : Set gamma correction value per 0.01 step. Do not change the value when obtaining image.

## 4.15. Defective Pixel Correction

- Defective pixel correction registered at factory  
 CIS compensates noticeable CMOS pixel defects found upon shipment from our factory.  
 User can disable this function.  
 [Note]  
 This function cannot be used with ROI function.

PixelCorrectionControl	
DefectPixelCorrectionEnable	True/False
DefectPixelDisplay	True/False

- DefectPixelCorrectionEnable : Set "True" to correct the registered defective pixels.
- DefectPixelDisplay : Set "True" to indicate the registered defective pixels as white spots.

## 4.16. Noise Filter

- This is a function to correct defective pixels in real time. Make sure that DefectPixelCorrectionEnable is "True" to use this function.

[Note]  
 This function cannot be used with ROI function.

PixelCorrectionControl	
NoiseFilter	True/False
NoiseFilterThreshold	0~4095

- NoiseFilter  
 Invalid with "False".  
 In case of "True", correct the pixel which difference between peripheral pixels and the pixel of interest is bigger than the NoiseFilterThreshold value.  
 ※ Adverse effects may occur due to overcorrection. Make sure to check the image when use this function.  
 ※ When threshold setting is 4095, defective pixel correction becomes invalid.  
 ※ Check images to adjust threshold.

4.17. Strobe Pulse Control

- Output exposure and readout timing externally from STRB\_OUT. With Manual Strobe, this function becomes valid with external trigger sync mode (FrameStart).

- No Strobe      Stop output (Always at Lo)
- Wide Strobe    Output from starting exposure of the 1st line to complete sensor readout (Exposure+Readout).
- Narrow Strobe    Output only when all sensor lines (from the 1st line to the last line) are exposed. Operate only when long time exposure (Exposure time longer than 1 frame) is set.
- Manual Strobe    Set rising and falling edges arbitrarily with StrobeDelay and StrobeWidth.

LightControl	
StrobeSelector	No Strobe Wide Strobe Narrow Strobe Manual Strobe
StrobeDelay	0~1000000 Designate delay time from the trigger to strobe pulse by $\mu\text{s}$ . ※ Valid when StrobeSelector is Manual Strobe.
StrobeWidth	1~1000000 Strobe pulse width (Designate by $\mu\text{s}$ ). ※ Valid when StrobeSelector is Manual Strobe.

※ If the set time (set with StrobeDelay+StrobeWidth) is longer than trigger cycle, strobe pulse might operate incorrectly.

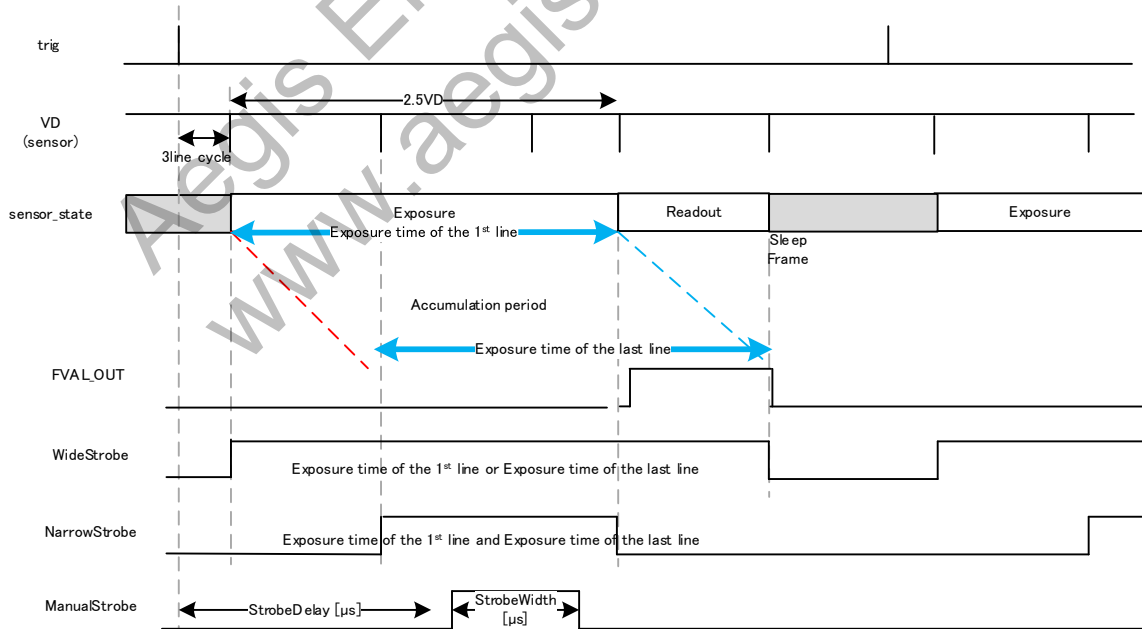

4.18. Device Temperature Control Function

This is a function to control the temperature of the device.

DeviceControl	
DeviceTemperature	ReadOnly
DeviceTemperatureUpperLimit	29~39
DeviceTemperatureLowerLimit	25~35
DeviceFanEnable	True/False

- DeviceTemperature : Indicate image sensor temperature by Celsius. Updates value every 3 seconds.
- DeviceTemperatureUpperLimit : Upper limit of the device temperature controlled by the fan.
- DeviceTemperatureLowerLimit : Lower limit of the device temperature controlled by the fan.
- DeviceFanEnable : Control the rotation of the fan inside the device. Rotates with True and stops with False.
- ※ The setting range of lower limit must be at least 4°C lower than the upper limit.
- ※ Depending on the ambient temperature, the temperature that exceeds the upper and lower limit may be indicated in DeviceTemperature.
- ※ To update DeviceTemperature value in 3 seconds, Polling function of the frame grabber board must be enabled.

How to control

- Control the device temperature by controlling the rotation speed of the fan inside the device, with the average of upper and lower limit as the target value.
- Temperature sensor is positioned next to the image sensor.

4.19. Link Speed and Link Count

TransportLayerControl	
ConnectionConfig	CXP6_X4

- CXP6\_X4 : Link speed=6.250Gbps, Link count=4

4.20. How to Save and Initialize Settings

Execute "UserSetSave" to save settings into camera non-volatile memory. Camera operates with saved settings upon next rebooting.

UserSets	
UserSetSelector	Default UserSet0 UserSet1
UserSetLoad	Execute
UserSetSave	Execute
UserSetDefault	Default UserSet0 UserSet1

- UserSetSelector : Select camera set values.  
Only UserSetLoad is valid when selecting Default. UserSetSave is invalid.
- UserSetLoad : Load the camera set values selected with UserSetSelector from camera non-volatile memory.

Readout factory setting data when UserSetSelector is Default.

- UserSetSave : Save camera set values.

Only UserSetLoad is valid when selecting Default. UserSetSave is invalid.

- UserSetDefault : Select camera set values of starting up the camera.

Load the selected set values and start-up the camera.

※ ShadingData will not be saved with UserSetSave. It will be saved to camera non-volatile memory by ShadingDataSave command.

- Camera will change the set values to the loaded values after executed UserSetLoad. Commands might not be updated depending on the indication software you use. In that case, please update again.

#### 4.21. White Balance

AnalogControl	
BalanceRatioSelector	Red Blue
BalanceWhiteAuto	Off Once
BalanceRatio	1.00~8.00

- BalanceWhiteAuto : This is to adjust white balance gain automatically.

Off : Waiting

Once : Adjust white balance automatically with one push.

Select "Once" of BalanceWhiteAuto to adjust white balance automatically and return to off. BalanceRatio shows new gain of color component selected with BalanceRatioSelector. Shoot an object with achromatic color to full screen to execute BalanceWhiteAuto. Recommendation is approx. 50% of signal level to

execute.

※ Turn On RegionMode to set BalanceWhiteAuto to Once.

Enables the following commands only when BalanceWhiteAuto is Off.

- BalanceRatioSelector : This is to select the color component you wish to change with BalanceRatio

- BalanceRatio : This is to set gain in the range of x1~x8.

If user set 1.0 to BalanceRatio of Red/Blue when BalanceRatioSelector = Red/Blue, white balance becomes disabled (WB through).

## 5. Factory Settings

Function	Initial Data	Explanation
<b>DeviceControl</b>		
DeviceIndicatorMode	Active	
DeviceTemperatureUpperLimit	39	
DeviceTemperatureLowerLimit	25	
DeviceFanEnable	True	
<b>ImageFormatControl</b>		
RegionMode	On	
Width	19568	
Height	12588	
OffsetX	0	
OffsetY	0	
PixelFormat	BayerRG8	
CursorPattern	Off	
CursorOffsetX	9784	
CursorOffsetY	6294	
CursorColor	White	
TestPattern	Off	
<b>AcquisitionControl</b>		
TriggerSelector	AcquisitionStart	
TriggerActivation	RisingEdge	
TriggerSource	LinkTrigger0	
ExposureTime	100000	
<b>AnalogControl</b>		
Gain	1.0	
BlackLevel	0	
ShadingCorrectionDataSelector	0	
ShadingCorrection	False	
Gamma	1.0	
BalanceRatioSelector	Red	RAW model
BalanceWhiteAuto	Off	RAW model
BalanceRatio	1.00	RAW model
<b>LightControl</b>		
StrobeSelector	NoStrobe	
StrobeDelay	0	
StrobeWidth	1	
<b>OpticalBlackControl</b>		
OBClampOffset	0	
<b>PixelCorrectionControl</b>		
DefectPixelCorrectionEnable	True	
DefectPixelDisplay	False	
<b>TransportLayerControl</b>		
ConnectionConfig	CXP6_X4	

※ Factory setting data are the same as UserSetDefault command.

6. Dimensions

6.1. Camera Dimensions

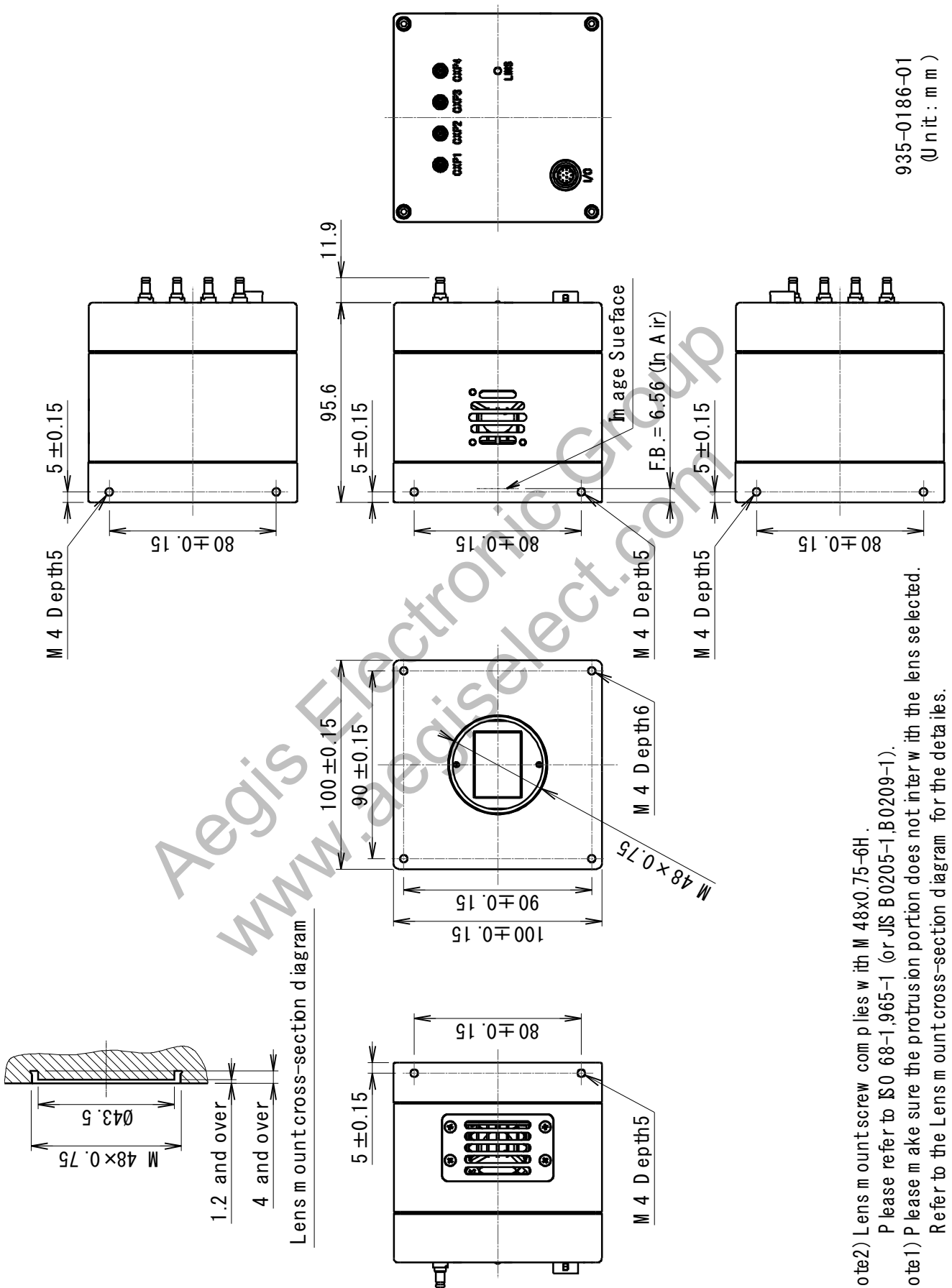

935-0186-01  
(Unit: mm)

Note2) Lens mount screw complies with M 48x0.75-6H.  
Please refer to ISO 68-1,965-1 (or JIS B0205-1,B0209-1).  
Note1) Please make sure the protrusion portion does not interfere with the lens selected.  
Refer to the Lens mount cross-section diagram for the details.

6.2. Optical Axis Accuracy

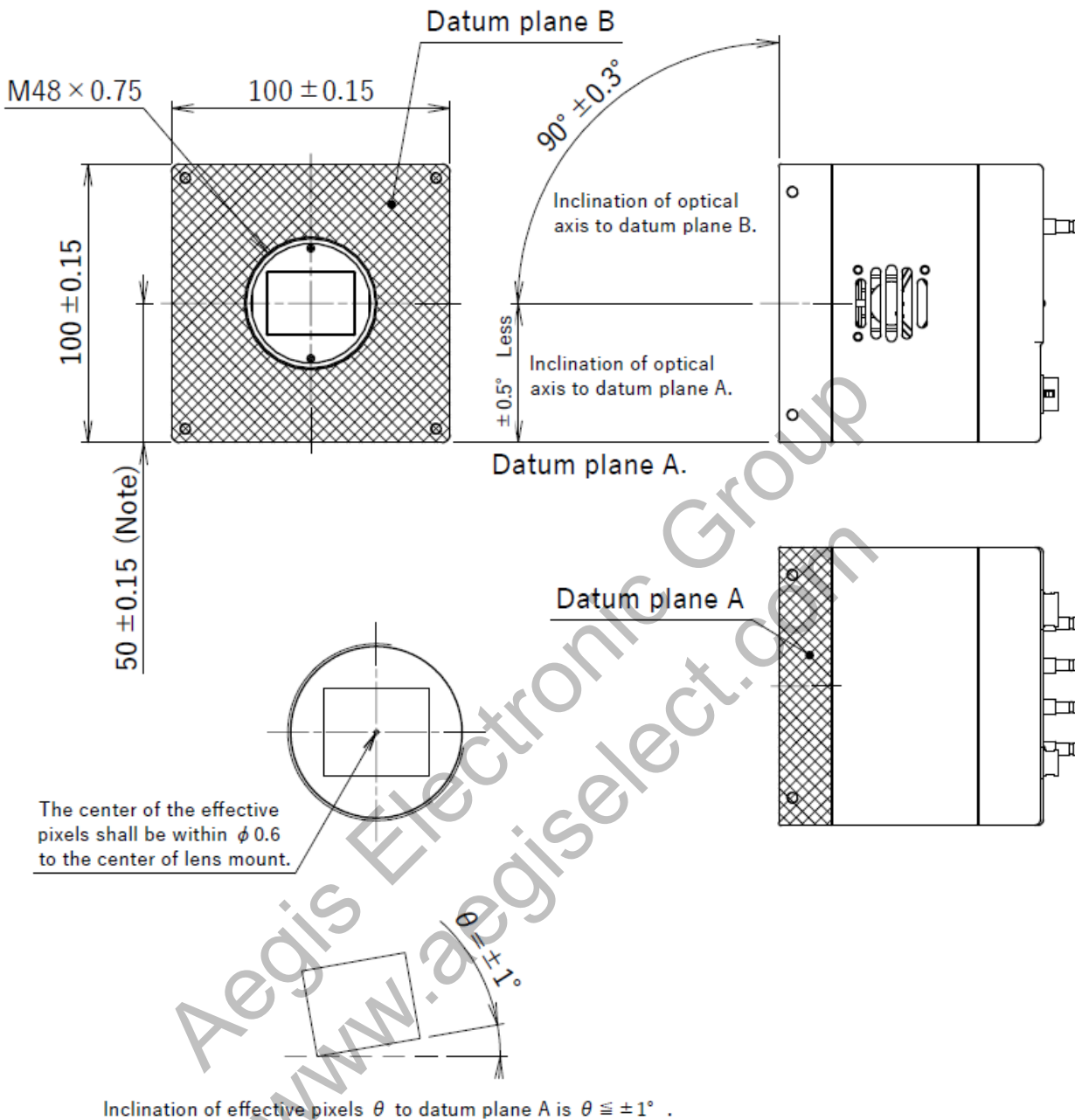

Note: Dimensions from datum plane A to the center of the lens mount.

937-0038-00  
(Unit : mm)

## 7. Case for Indemnity (Limited Warranty)

### 7.1. Product Warranty

The term of warranty of this product is within 3 years from the date of shipping out from our factory.

If you use the product properly and discover a defect during the warranty period, and if that was caused by designing or manufacturing, CIS Corporation, at its option, repairs or replaces it at no charge to you. Products out of warranty period will be subject to charge.

CIS should not hold responsible for damages or losses if;

- damages or losses are caused by earthquake, lightning strike, fire, flood or other acts of God.
- damages or losses are caused by deliberate or accidental misuse by user, or failure to observe the information contained in the instructions in this Product Specification and Operational Manual.
- damages or losses are caused by repair or modification conducted by customer or any unauthorized party.

### 7.2. CMOS Defective Pixels

CIS applies defective pixel correction prior to the shipment of the product. However, the number of defective pixels are subject to increase due primarily to the effect of cosmic rays. Due to this nature, CIS should not hold responsible for the natural increase of defective pixels.

### 7.3. Product Support

Should you have any problems in function of the product you purchased, and if you need our further analysis and/or repair, please contact your local distributor.

Aegis Electronic Group  
www.aegiselect.com