

# CIS

CoaXPress I/F

12M Pixel CMOS B&W Camera

## VCC-12CXPHSM

# Product Specifications & Operational Manual

(Preliminary)

**CIS Corporation**

PRELIMINARY  
Aegis Electronic Group  
www.aegiselect.com

## table of contents

<b>1. Precautions for handling</b> .....	1
1.1. Camera Handling Precautions .....	1
1.2. Restrictions on Applications .....	エラー! ブックマークが定義されていません。
1.3. disclaimer .....	1
<b>2. Product Overview</b> .....	2
2.1. feature .....	2
2.2. Bundled Items .....	エラー! ブックマークが定義されていません。
<b>3. Specifications</b> .....	3
3.1. General Specifications .....	3
3.2. Camera Input/Output Specifications .....	4
3.2.1 Trigger Input (6-Pin Connector 3-pin or Pin-5) .....	4
3.2.2 Signal Output (6-Pin Connector 3-pin or Pin-5) .....	4
3.3. External Connector Pin Assignment .....	エラー! ブックマークが定義されていません。
3.3.1 6-Pin Circular Connectors .....	5
3.3.2 75 Ω Micro BNC Connector .....	5
3.3.3 LED Indicators .....	5
3.4. Spectral Response .....	6
<b>4. Camera Operational Function</b> .....	7
4.1. Control System .....	7
4.2. Device Information .....	7
4.2.1 Camera Information .....	7
4.2.2 User Information .....	7
4.3. Saving and Initializing Settings .....	7
4.4. Link speed and number of links .....	8
4.5. Pixel format .....	9
4.6. Frame rate .....	9
4.7. Flip .....	9
4.8. Trigger-Mode .....	10
4.8.1 Internal Sync Mode (Free Run Mode) .....	10
4.8.2 External Sync Mode .....	11
4.8.3 External Sync Mode (Fixed Trigger Shutter Mode) .....	11
4.8.4 External Sync Mode (Pulse Width Trigger Shutter Mode) .....	12
4.8.5 Restrictions on Trigger Pulse Input Timing .....	13
4.9. Gain .....	14
4.10. Gamma correction .....	14
4.11. Exposure Time .....	155
4.12. Partial Scan (SingleROI) .....	15
4.13. Partial Scan (MultiROI) .....	16
4.13.1 Example Configuration .....	17
4.14. Binning .....	18
4.15. Defect pixel correction .....	19
4.16. Noise Filter .....	21
4.17. Shading Correction .....	22
4.18. Black Level Adjustment .....	22
4.19. Test Pattern Indication .....	23
4.20. Cursor Indication .....	23
4.21. LED Operating Modes .....	23

4.22. Temperature Indication ..... 24

4.23. Camera Timing IO..... 24

4.24. SourceTag Reset ..... 25

**5. Factory Settings** .....266

**6. Dimensions** .....288

6.1. Camera Dimensios .....288

6.2. Optical Axis Accuracs .....299

**7. Case for Indemnity (Limited Warranty)** ..... 30

7.1. Product Warranty .....3030

7.2. CMOS pixel defects. ....3030

7.3. Products Support .....3030

PRELIMINARY

Aegis Electronic Group  
www.aegiselect.com

## 1. Handling Precautions

### 1.1. Camera Handling Precautions

- For camera protection, do not use in dusty or humid areas.
- Handle the camera carefully to avoid strong shocks and static electricity. It can cause a breakdown.
- To protect the CMOS image sensor, please do not directly image direct sunlight or high-brightness lights. Also, when not in use, please wear a protective cap.
- The connection to the camera is defined as "3.3.External Connection Connector Specifications. Please note that incorrect connections can not only damage the camera itself, but also cause irreparable failure to the connected equipment.
- If there is an AC leak from the device connected to the camera (monitor/computer, etc.), the camera may be broken. Please check the ground potential between each other and make sure that there is no problem before connecting.
- The power supply voltage of the camera should be used correctly within the specifications. If you use a power supply that does not meet the specifications or is unstable, the camera may malfunction or malfunction.
- All camera failures or malfunctions caused by incorrect use without following the above precautions are not covered by the product warranty.

### 1.2. Restrictions on Applications

- This product is not designed and manufactured with the consideration that it will be used in devices that are directly related to human life, devices that may harm the human body, the space industry, etc., and should not be used for those applications.
- Please avoid using it under conditions or environments other than those specified, especially in applications where safety is required, or contact us.

### 1.3. Disclaimer

- Damage or breakdown caused by earthquakes, lightning, floods, fires, or other force majeure is not covered by the warranty.
- Damage caused by the customer's negligence or damage caused by failure to comply with the contents of this specification is not covered by the warranty.
- Failures caused by repairs or modifications made by customers other than our company are not covered by the warranty.

## 2. Product Overview

The VCC-12CXPHSM is a CoaXPress output camera using a 1.1-inch 12-megapixel CMOS image sensor.

### 2.1. Feature

- Enclosure size 47mm x 47 mm x 30 mm
- Global Shutter CMOS Sensor (Monochrome)
- CoaXPress CXP-6/CXP-12
- 1 lane
- PoCXP support
- Maximum cable length 24m (CXP-12), 40m (CXP-6)
- ROI/Multi-ROI
- Binning addition and average
- Exposure, Gain Settings
- External trigger mode (fixed trigger shutter mode / pulse width trigger shutter mode)
- Compliant with CoaXPress standard (GenICam support)
- C-mount

### 2.2. Bundled Items

- Standard Bundled Items
  - Camera module VCC-12CXPHSM

### 3. Specifications

#### 3.1. General Specifications

Electrical Specifications			
Pixel sensor	Imaging Devices	1.1-inch global shutter CMOS	
	Effective number of pixels	4096(H) × 3072(V)	
	Pixel size	3.4μm(H) × 3.4μm(V)	
Video Output Mode		Ver., 1.1.1 compatible, CXP6_X1 / CXP12_X1	
Video output frequency	Pixel Clock Frequency	72MHz	
Video Output Format		Mono8 / Mono10 / Mono12	
Frame rate	CXP6 8bit/10bit/12bit	46.0fps/35.8fps/23.7fps	
	CXP12 8bit/10bit/12bit	92.0fps/71.6fps/47.4fps	
Synchronous method		Internal synchronization	
Video output pixel size (maximum pixel size)		4096 (H) × 3072(V)	
Video Signal (Gain 0dB)	White clip level	255digit	MONO 8bit
	Setup Levels	0~1digit	MONO 8bit, factory settings
	Dark Shading	0~1 digit (H/V)	MONO 8bit, factory settings
Standard Sensitivity		F8, 1x (Mono12, 40000 μs, other shipping settings)	
Minimum subject illumination		TBD (Mono12, 40000 μs, Gain x32, level=50%, other shipping settings)	
Variable gain		x1~x32 (0dB~+36dB)	
Shutter speed		7[μs]~100,000[μs]	
Gamma correction		Yes (γ=0.1~1.8)	
Trigger-Mode		Freerun mode (internal camera trigger) Trigger Mode (Host, External Terminal) Fixed trigger shutter Pulse width trigger shutter	
Partial Scan		8-zone (max), vertical & horizontal variable size (However, horizontal offsets are common across all ROIs.)	
Supply voltage		PoCXP: 18.5~26V	
Power consumption		TBD 4.4W(CXP12) [Freerun]	
Mechanism Specifications			
Dimensions		H: 47mm W: 47mm D: 31mm Excluding protrusions	
weight		99 g	
Lens mount		C-mount	
Usage Environment Specifications			
Fit Specifications		CE Acquisition EMC Directive 2014/30/EU Conformity Standard Emission: EN61000-6-4:2019 Immunity: EN61000-6-2:2019 RoHS Directive 2011/65/EU (EU)2015/863	
durability	Vibration resistant	acceleration	: 98m/s <sup>2</sup> (10G)
		frequency	: 20 ~ 200Hz
		direction	: X, Y, Z 3 directions
		Exam time	: 120 points in each direction
	Impact resistance	It must be able to withstand shocks of up to 980 m/s <sup>2</sup> (100) G applied in the six directions of ±X, ±Y, ±Z without packing.	
Guaranteed operating temperature		0 ~ +45°C	

	Humidity 20 ~ 80%RH However, it should not condense.
Storage temperature	-25 ~ +60°C Humidity 20 ~ 80%RH However, it should not condense.

## 3.2. Input/Output Specifications

### 3.2.1 Trigger Input (6-pin connector, pin 3 or pin 5)

- Open Collector Input
- You can enter triggers directly from external devices.

If you want to use this terminal, set the following:

- Set the LineSelector of the DigitalIOControl to Line0 (pin 3) or Line1 (pin 5).
- Set DigitalIOControl's LineMode to Input.
- Set the LineSource of the DigitalIOControl to FrameTrigger.
- Set the TriggerSource of the AcquisitionControl to match the LineSelector.

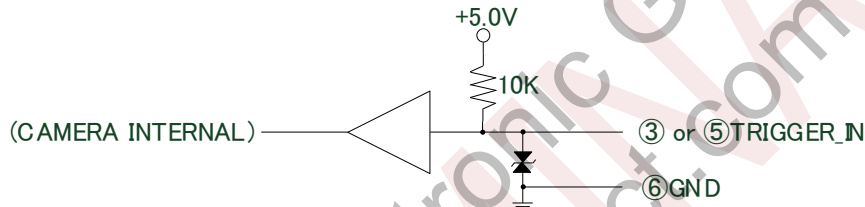

### 3.2.2 Signal Output (6-pin connector, pin 3 or pin 5)

- Open collector output
- It can output the timing signal inside the camera.

If you want to use this terminal, set the following:

- Set the LineSelector of the DigitalIOControl to Line0 (pin 3) or Line1 (pin 5).
- Set DigitalIOControl's LineMode to Output.
- Set to signal to output DigitalIOControl's LineSource.

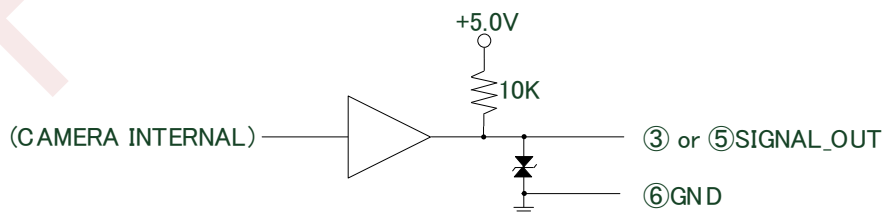

### 3.3. External Connector Pin Assignment

#### 3.3.1 6-pin circular connector

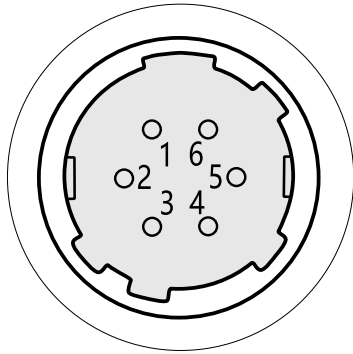

HR10-7R-6PA (Hirose) equivalent

Pin Number	Signal Name	remarks
1	NC	
2	NC	
3	Line0	TRIGGER_IN SIGNAL_OUT (Exposure/FVAL/LVAL/LinkTrigger Selective Output)
4	NC	
5	Line1	TRIGGER_IN SIGNAL_OUT (Exposure/FVAL/LVAL/LinkTrigger Selective Output)
6	Common	TRIGGER_IN. Return of SIGNAL_OUT (common)

\*NC = Non-Connection. Do not connect anything to the terminals.

#### 3.3.2 75 Ω Micro BNC Connector

- This is the image output signal of CoaXPress.
- It supports PoCXP.

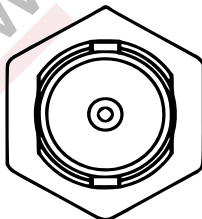

#### 3.3.3 LED Indicator

- When DeviceIndicatorMode is set to Active, the luminous state indicates the status of the camera.

LED status	Camera Status
off	No power supply
Green Lighting	Device and host connection established
Green Fast Flashing [12.5Hz]	During video data transfer
Orange Low flashing [1Hz]	Waiting for trigger input
Red Fast Flashing [12.5Hz]	System error occurrence/trigger error occurrence

### 3.4. Spectral Response

\* Excludes lens characteristics, optical glass characteristics, and light source characteristics.

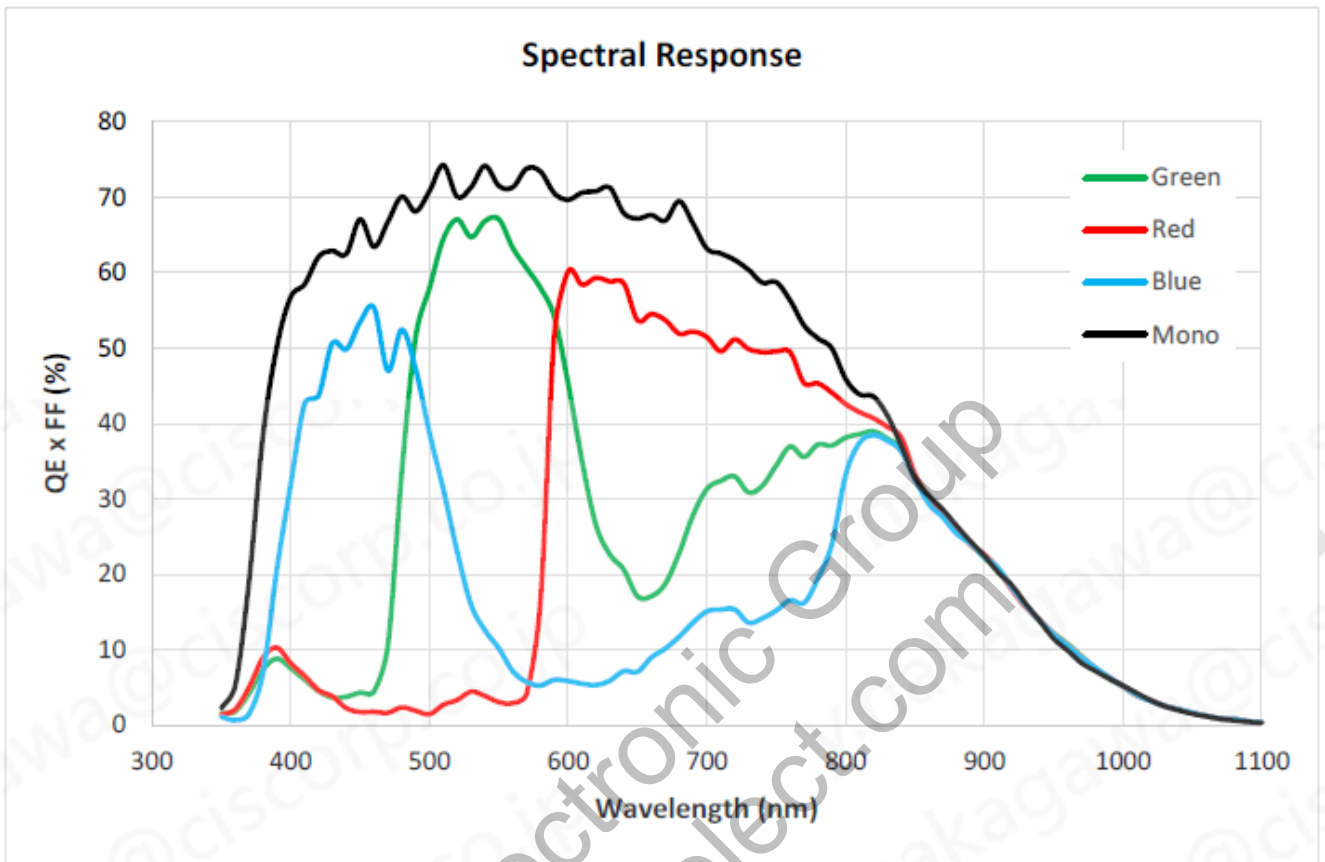

## 4. Camera Operational Function

### 4.1. Control System

- Complies with the CoaXPress standard.

Each configuration item name complies with GenICam SFNC (Standard Features Naming Convention).

(Some of the settings have their own settings)

The corresponding SFNC versions are DeviceSFNCVersionMajor, DeviceSFNCVersionMinor, You can get it with DeviceSFNCVersionSubMinor.

### 4.2. Device Information

#### 4.2.1 Camera Information

DeviceControl	
DeviceModelName	ReadOnly
DeviceVersion	ReadOnly
DeviceFirmwareVersion	ReadOnly
DeviceSerialNumber	ReadOnly

- DeviceModelName : Camera model name
- DeviceVersion : Circuit version
- DeviceFirmwareVersion : Firmware Versions
- DeviceSerialNumber : Camera Serial No.

TransferLayerControl		
DeviceTapGeometry	Geometry_1X_1Y	ReadOnly

#### 4.2.2 User Information

DeviceControl	
DeviceUserID	Manual
DeviceUserString	Manual

You can set a string (including NUL characters (¥0)) for the DeviceUserID and up to 256 characters for the DeviceUserString for the camera. When you run "UserSetSave", it is stored in the non-volatile memory in the camera.

- Regardless of the UserSetSelector, it is a setting in the camera.
- Running UserSetLoad with UserSetSelector=Default maintains the current settings.
- When launched with UserSetDefault=Default, it reads out the saved settings.

### 4.3. Saving and Initializing Settings

- This function stores the operating settings in the camera's non-volatile memory and loads the settings in the non-volatile memory.

UserSets		
UserSetSelector	Default UserSet0 UserSet1 UserSet2	[Not eligible for saving settings]
UserSetLoad	(Execute)	
UserSetSave	(Execute)	

UserSetDefault	Default UserSet0 UserSet1 UserSet2
----------------	---

- ♦ UserSetSelector : Select the setpoint in the non-volatile memory to store or read the current setpoint.
    - Default : Factory Initial Settings (UserSetLoadOnly executable. UserSetSave is not executable)
    - UserSet[0|1|2] : User Settings
  - ♦ The Default area has the default settings, so you cannot save any settings.
  - ♦ The value of the UserSetSelector cannot be saved even if you run UserSetSave. It will always be the same as UserSetDefault at startup.
  - ♦ Select UserSetLoad or UserSetSave each time you run.
  - ♦ UserSetLoad : UserSetSelectorLoad the camera settings in the area from the non-volatile memory. If the UserSetSelector is Default, it reads the factory settings, but the CxpLinkConfiguration, PixelFormat, DeviceUserID, DeviceUserString, UserSetDefault, defective pixel correction values, and shading correction values are Maintain the settings during operation. Even if the UserSetSelector is UserSet0,1,2, the CxpLinkConfiguration, PixelFormat will still maintain the settings in action.
  - ♦ UserSetSave : UserSetSelectorSave the camera settings in the area. When Default is selected, only UserSetLoad is enabled, and UserSetSave is not possible.
  - ♦ UserSetDefault : Select the settings when the camera starts. Load the selected settings and the camera will start. Even if Default is selected, DeviceUserID, DeviceUserString, defect pixel correction values, and shading correction values will read the saved settings.
- UserSetDefault stores the settings immediately when set.
  - UserSetLoad should not be executed while grabbing (while fetching images).
  - The following settings have a single storage area and do not depend on UserSet0, 1, or 2, but are stored with UserSetSave. UserSetDefault, DeviceUserID, DeviceUserString, defect pixel correction value, shading correction value

The combination for saving and performing the invocation of the settings is as follows:

UserSetSelector	UserSetLoad/UserSetSave	function
Default	UserSetLoad	Factory Settings Call
	UserSetSave	- (Cannot be executed)
UserSet[0 1 2]	UserSetLoad	User Settings Call
	UserSetSave	User Settings Save

#### 4.4. Link speed and number of links

Transfer Control	
CxpLinkConfiguration	CXP6_X1 CXP12_X1

- ♦ CXP6\_X1 : Link speed = 6.250 Gbps, number of links = 1
- ♦ CXP12\_X1 : Link speed = 12.500 Gbps, number of links = 1

※ Do not change CxpLinkConfiguration while grabbing (while acquiring images).

#### 4.5. Pixel format

ImageFormatControl	
PixelFormat	Mono8 Mono10 Mono12

- ♦ PixelFormat: Choosing a pixel format
  - Mono8: monochrome8-bit
  - Mono10: monochrome10-bit
  - Mono12: monochrome12-bit
- \* Do not change the PixelFormat while grabbing (while acquiring an image).

#### 4.6. Frame rate

AcquisitionControl	
AcquisitionFrameRate	AcquisitionFrameRate.Min~AcquisitionFrameRate.Max

Set the frame rate (Hz) for the internal sync mode.

Make sure you don't change it while the image is being acquired.

- ♦ AcquisitionFrameRate.Min : Lower limit 10Hz
- ♦ AcquisitionFrameRate.Max : Varies depending on the upper limit PixelFormat, ROI(Height) settings.
- ※ Binning does not increase the frame rate.
- ※ The frame rate is adjusted by increasing the number of vertical blanks.  
This may cause errors with the frame rate you set.

The frame rate can be calculated using the following formula:

**Frame rate [Hz] = 1 / ( 1 line time × (number of vertical blanking lines + number of output image lines) )**

Please refer to the table below for the time of one line at full-frame output and the fastest frame rate.

CxpLinkConfiguration	PixelFormat	1 line time[us]	Number of vertical blanking lines	Frame rate at full frame [Hz]	Frame time at full frame
CXP12_X1	Mono8	3.5	33	92.01748657226563	10867
	Mono10	4.5	33	71.56915283203125	13973
	Mono12	6.8	33	47.3619384765625	21114
CXP6_X1	Mono8	7.0	33	46.00874328613281	21735
	Mono10	9.0	33	35.784576416015625	27945
	Mono12	13.6	33	23.68096923828125	42228

#### 4.7. Flip

ImageFormatControl	
ReverseX	True/False
ReverseY	True/False

- ♦ ReverseX : Flip the image horizontally

- ♦ ReverseY : Flip the image vertically
- \* Do not change ReverseX/Y while grabbing (while acquiring images).
- \* SingleROI OffsetX and OffsetY, MultiROI SensorROIOffsetX [SensorROISelector], SensorROIOffsetY [SensorROISelector]The setting value of ReserseX or ReserseY is automatically updated when it is changed.

### 4.8. Trigger-Mode

There are two trigger modes: internal synchronization mode and external trigger mode. You can select it with the following command:

Acquisition Control	
TriggerMode	Off/On
TriggerSelector	AcquisitionStart FrameStart

On this camera, the TriggerMode and TriggerSelector settings will be the same.

Changing the TriggerMode will change the TriggerSelector, and changing the TriggerSelector will synchronize the TriggerMode.

- ♦ TriggerMode : Trigger Mode
  - ♦ Off : Internal Sync Mode(Free Run Mode)It works with. (TriggerSelector = AcquisitionStart)
  - ♦ On : Works in external trigger mode.(TriggerSelector = FrameStart)
  - \*Do not change the TriggerMode while grabbing (while acquiring an image).
- ♦ TriggerSelector : Trigger Selector
  - Select the method and polarity to start the video capture from the following.
  - ♦ AcquisitionStart : Internal Sync Mode(Free Run Mode)It works with. (TriggerMode = Off)
  - ♦ FrameStart : Works in external trigger mode. (TriggerMode = On)
  - \*Do not change the TriggerSelector while grabbing (while capturing an image).

#### 4.8.1 Internal Sync Mode (Freerun Mode)

- This mode does not require external trigger input, and reads out the video using a trigger that is continuously created inside the camera.
- Set TriggerMode to Off and TriggerSelector to AcquisitionStart.
- You can change the frame rate in the AcquisitionFrameRate setting.

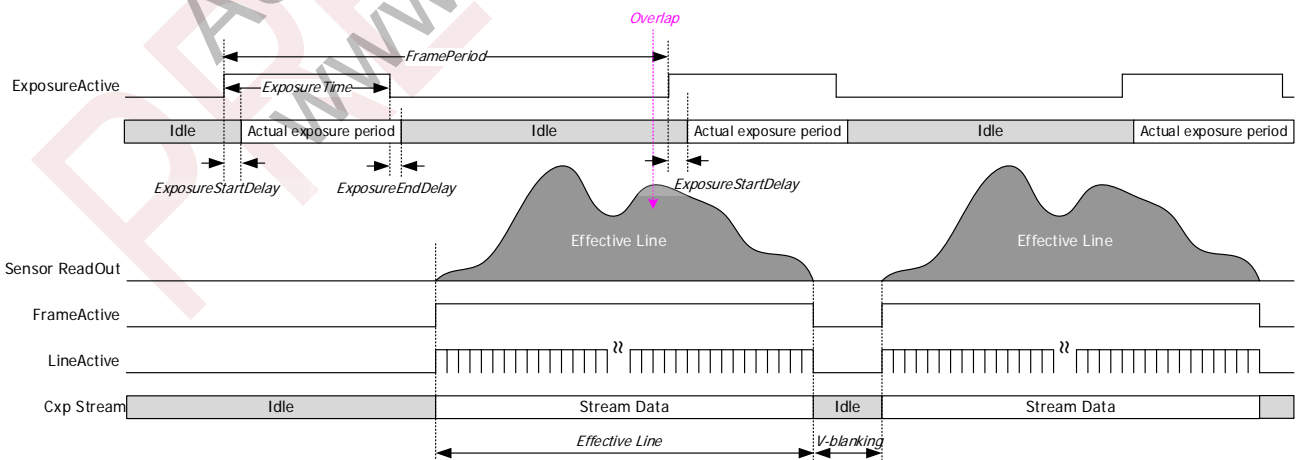

Vertical Sync Timing Chart (Freerun Mode)

Timing Parameter	Value	Description
ExposureStartDelay	2	Delay time from ExposureActive rise to completion of exposure inside

		the sensor [H]
ExposureEndDelay	36 25	Delay time from exposureActive descent to completion of exposure inside the sensor [ $\mu$ s] Mono8/Mono10 Mono 12 o'clock
V-blanking	33	Number of Vertical Blanking Lines [H]

#### 4.8.2 External Sync Mode

- This mode captures the video at any time by inputting a trigger signal.
- Set TriggerMode to On and TriggerSelector to FrameStart. When off, it is in internal sync mode.
- You can select advanced functions by using the following commands: (When selecting a function, please do it with the trigger input stopped.)

Acquisition Control	
TriggerActivation	RisingEdge FallingEdge LevelHigh LevelLow
TriggerSource	LinkTrigger0 Line0 Line1 Software
TriggerSoftware	(Execute)

- ◆ TriggerActivation : Trigger Activation  
Select the method and polarity in which you want to start the video capture.
  - ◆ RisingEdge : Fixed trigger shutter mode: Start exposure at rising edge (Timed)
  - ◆ FallingEdge : Fixed Trigger Shutter Mode: Start Exposure at Falling Edge (Timed)
  - ◆ LevelHigh : Pulse Width Trigger Shutter Mode: Exposure during High Active Period (TriggerWidth)
  - ◆ LevelLow : Pulse Width Trigger Shutter Mode: Exposure during Low Active Period (TriggerWidth)

\*Do not change the TriggerSelector while grabbing (while capturing an image).
- ◆ TriggerSource : Trigger Source  
Select the external trigger input destination.
  - ◆ Software : TriggerSoftware Enter a trigger in the command.  
\*You can select Software only when the TriggerActivation is RisingEdge.
  - ◆ LinkTrigger0: From the CoaXPress Host Device Enter a trigger.  
\*Please refer to the specification of the Host Device (grabber board, etc.) for how to generate triggers.
  - ◆ Line0/Line1 : Enter the trigger from the 6-pin circular connector.  
※ LineMode[LineSelector]=InputAnd also LineSource[LineSelector]=FrameTriggerYou can choose if it is.
- ◆ TriggerSoftware : Software Triggers  
Issue a software trigger. Generate a trigger inside the camera and shoot one frame.
  - \* This can only be done when the TriggerSource is set to Software.

#### 4.8.3 External Sync Mode (Fixed Trigger Shutter Mode)

(TriggerMode = On, TriggerActivation = RisingEdge or FallingEdge)

- This mode starts the exposure with an external trigger input and performs the exposure at the time set by the ExposureTime command.

- The trigger is synchronized to the CLK in the camera to initiate the exposure with low latency.
- The timing chart and timing parameters in this operating mode are shown below.

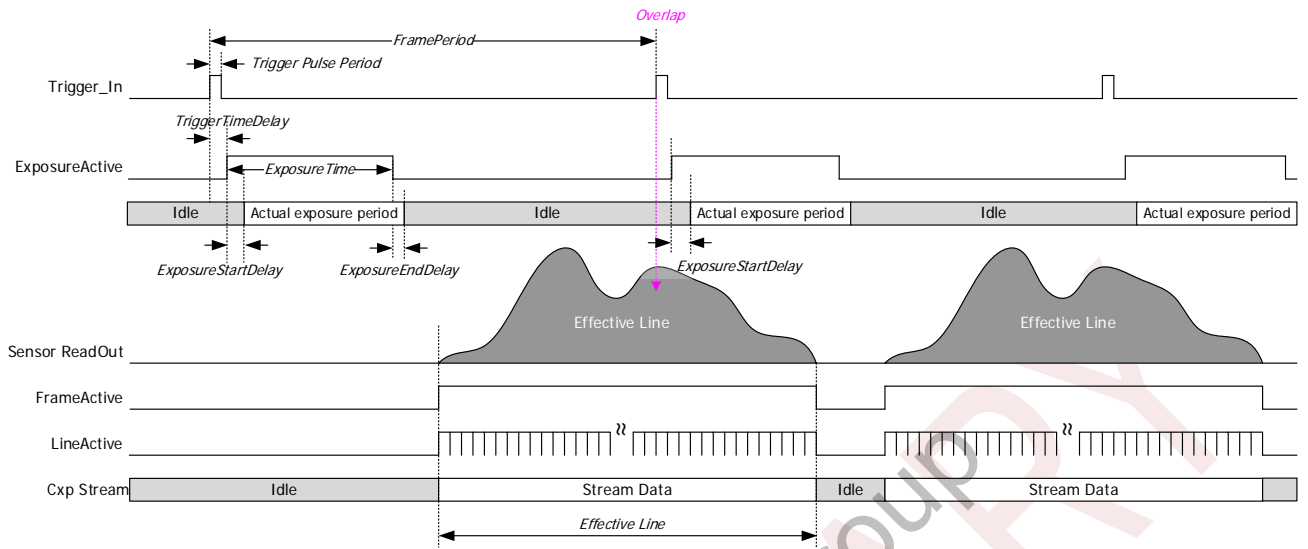

Vertical Sync Timing Chart (Fixed Trigger Shutter Mode)

Timing Parameter	Value	Description
Trigger Pulse Period	1	Trigger Input Pulse Width (Minimum) [ $\mu$ s]
Trigger Time Delay	0.08~0.14	Delay time from trigger input rise to ExposureActive rise [ $\mu$ s]
ExposureStartDelay	2	Delay time from ExposureActive rise to completion of exposure inside the sensor [H]
ExposureEndDelay	36	Delay time from exposureActive descent to completion of exposure inside the sensor [ $\mu$ s]
	25	Mono8/Mono10
		Mono 12 o'clock

\*1H indicates the time of 1 line. See the frame rate section.

- ※ The trigger period must be longer than the FVAL period (frame data read time).
- ※ The trigger period should be longer than the exposure time.
- ※ Please note that there will be a delay in trigger input to the camera and the actual exposure time.

#### 4.8.4 External sync mode (pulse width trigger shutter mode)

(TriggerMode = On, TriggerActivation = LevelHigh or LevelLow)

- This mode starts the exposure with an external trigger input and controls the exposure time with the trigger pulse width.
- The trigger is synchronized to the CLK in the camera to initiate the exposure with low latency.
- The shortest trigger width is shown in the table below.

CXP Rate	PixelFormat	TriggerPulsePeriod Minimum trigger width [ $\mu$ s]
CXP12	Mono8	7.01
	Mono10	9.01
	Mono12	13.61

CXP6	Mono8	14.01
	Mono10	18.01
	Mono12	27.21

- It is also possible to perform long exposures by extending the pulse width of the trigger. However, during long exposures, dark noise and shading noise may be noticeable.
- The timing chart and timing parameters in this operating mode are shown below.

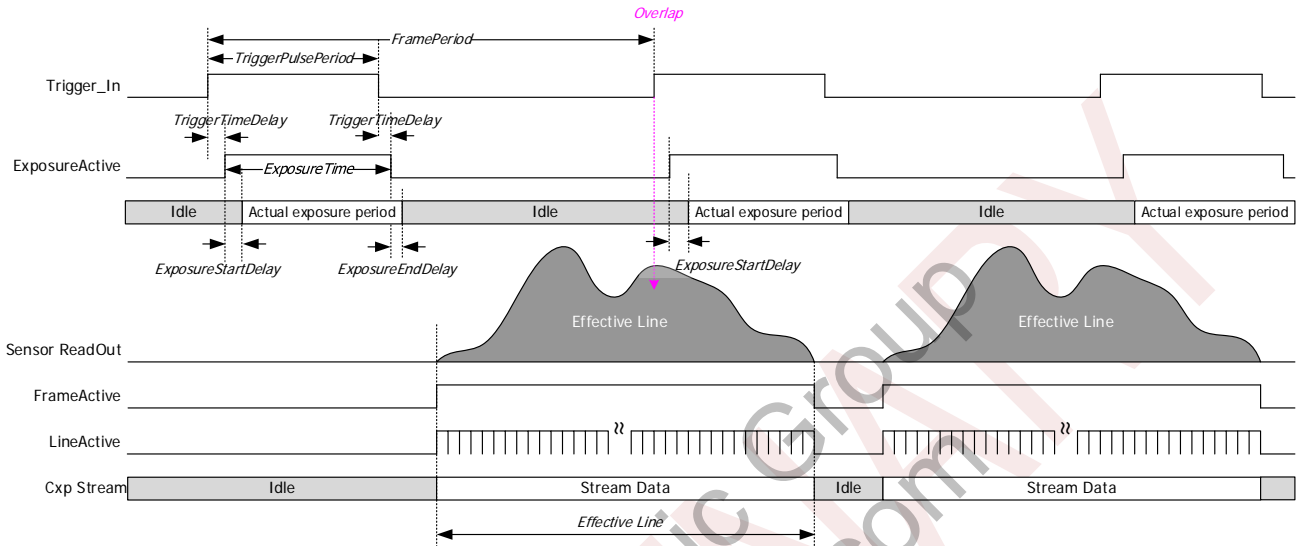

Vertical Synchronization Timing Chart (Pulse Width Trigger Shutter Mode)

Timing Parameter	Value	Description
Trigger Time Delay	0.08~0.14	Delay time from trigger input rise to ExposureActive rise [μs]
ExposureStartDelay	2	Delay time from ExposureActive rise to completion of exposure inside the sensor [H]
ExposureEndDelay	36	Delay time from exposureActive descent to completion of exposure inside the sensor [μs]
	25	

\*1H indicates the time of 1 line. See the frame rate section.

※ The trigger period must be longer than the FVAL period (frame data read time).

#### 4.8.5 Restrictions on Trigger Pulse Input Timing

The input timing of external triggers has the following restrictions:

Please note that failure to meet these constraints will result in an error.

- You cannot enter a trigger when the exposure period of the next trigger is complete during image readout.

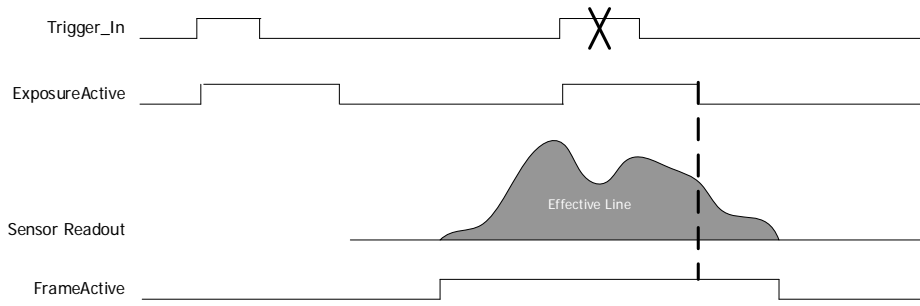

□ You cannot enter the following triggers during the exposure period:

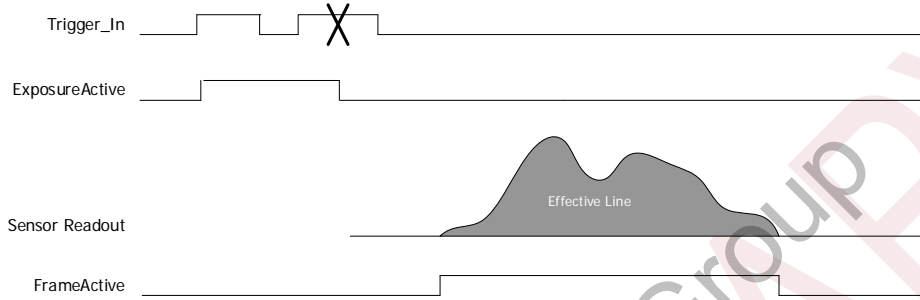

If an external trigger is entered during the ban period, the LED on the back of the camera will be in an error glowing state, and the status can be checked with the following command.

Acquisition Control	
IllegalTriggerFlag	0 or 1

♦ IllegalTriggerFlag: If there is a trigger input at the prohibition timing, it will be "1". It will be.

Device Control	
ErrorFlagReset	(Execute)

♦ ErrorFlagReset: IllegalTriggerFlag to "0" Reset to.

#### 4.9. Gain

AnalogControl	
Gain	1.00~32.00

Gain : You can set it arbitrarily from 1.00x to 32.00x in 0.01 steps.

It can be set up to 32.00x, but deterioration in image quality at high gain is inevitable.

Please use it after evaluation.

#### 4.10. Gamma correction

AnalogControl	
Gamma	0.10~1.80

Gamma: You can set the gamma correction value from 0.10~1.80 in 0.01 steps.

※ Gamma changes should not be performed while grabbing (while acquiring images).

#### 4.11. Exposure Time

Acquisition Control	
ExposureTime (μs)	ExposureTime.Min~100,000

ExposureTime :Exposure Time

The exposure time can be set in 1μs increments.

The exposure time calculation formula is as follows

Mono8/Mono10 {ExposureTime} + 36μs – ( 2 × Tline )  
 When Mono12 {ExposureTime} + 25μs – ( 2 × Tline )

※ Tline indicates 1 line time. See the frame rate section.

ExposureTime.Min : Lower Exposure Time Limit

CXP Rate	PixelFormat	ExposureTime.Min [μs]
CXP12	Mono8	8
	Mono10	10
	Mono12	14
CXP6	Mono8	15
	Mono10	19
	Mono12	28

ExposureTime.Max : Upper exposure time

- In internal sync mode:

CxpLinkConfiguration, PixelFormat, Height, and AcquisitionFrameRate settings.

The maximum exposure time values for full frame and maximum frame rate are as follows:

CXP Rate	PixelFormat	ExposureTime.Max [μs]
CXP12	Mono8	10794
	Mono10	13878
	Mono12	21039
CXP6	Mono8	21588
	Mono10	27756
	Mono12	42078

- In external synchronization mode: 100,000 μs

#### 4.12. Partial Scan (SingleROI)

- This is a mode that displays the area by cutting out the area vertically and horizontally.

By cutting out and reducing the area vertically, you can speed up the frame rate.

The frame rate does not change when the area is cut horizontally.

ImageFormatControl	
RegionSelector	Region0
RegionMode	Off/On
RegionDestination	Stream0
Width	64~4096
Height	64~3072
OffsetX	0~(4096-Width)
OffsetY	0~(3072-Height)

※ Please do not change the value while the image is being acquired.

SingleROI

- RegionSelector: Region0 is fixed.
- RegionMode: Configure in RegionSelectorToggle whether to enable or disable the Region.  
If RegionMode=On, Width/Height/OffsetX/OffsetY cannot be set.  
If you want to set it, set it to RegionMode=Off.  
\* BinningHorizontal=BinningVertical=1 must be set to On.
- RegionDestination: Stream0 is fixed.
- Width: Set the width of the Region. Set it to multiples of 8.
- Height: Set the height of the Region. Set it in multiples of 2.
- OffsetX: Set the offset in the X direction of the Region. Set it to multiples of 8.
- OffsetY: Set the offset in the Y direction of the Region. Set it in multiples of 2.
- ※ OffsetX and OffsetY must be configured to meet the following conditions:  
64 ≤ OffsetX+Width ≤ 4096  
64 ≤ OffsetY+Height ≤ 3072
- ※ For MultiROI (SensorROIEnable=True), Width/Height/OffsetX/OffsetY is not configurable and displays values indicating the area where MultiROI is integrated. Be sure to enable one or more ROIs. You can't save all ROI with disabled.
- ※ Cannot be used in conjunction with Binning.
- ※ It can be used in conjunction with shading correction and defect correction.

**4.13. Partial Scan (MultiROI)**

- This mode allows you to speed up the frame rate by cutting out and reducing multiple vertical areas.
- It cannot be used with binning, shading, defect correction, or noise filters.

ImageFormatControl	
SensorROIEnable	False/True
SensorROISelector	ROI0~ROI7 [Not eligible for saving settings]
SensorROIMode[SensorROISelector]	Off/On
SensorROIWidth[SensorROISelector]	64~4096
SensorROIHeight[SensorROISelector]	64~3072 ※
SensorROIOffsetX[SensorROISelector]	0~(4096-SensorROIWidth)
SensorROIOffsetY[SensorROISelector]	0~(3072-Height) ※

- ※ For SensorROIHeight and SensorROIOffsetY, make sure that the area of all valid SensorROIs does not exceed the area of 4096x3072. Also, make sure that the SensorROI regions set in each SensorROIHeight and SensorROIOffsetY do not overlap.
- ※ Make sure you don't change the values while retrieving the image.

MultiROI

- SensorROIEnable: MultiROI if set to TrueThe setting of the。  
※ ShadingCorrectionDataSelector=Off, DefectPixelCorrection=Off,  
BinningHorizontal=BinningVertical=1Otherwise, it cannot be enabled.

- **SensorROISelector:** SensorROI Mode, SensorROI Width, SensorROI Height,  
You can change the settings of SensorROI Offset X and SensorROI Offset Y.
- **SensorROI Mode:** Configure in SensorROI Selector Toggle whether to enable or disable the ROI that you have done.  
  
SensorROI Enable=False. If  
SensorROI Mode=On, SensorROI Width /SensorROI Height /SensorROI Offset X  
/SensorROI Offset Y cannot be set.  
  
If you want to change the settings, set it to SensorROI Mode=Off.
- **SensorROI Width:** MultiROI Set the width of each Region.  
The same settings for each ROI. Set it to multiples of 8.
- **SensorROI Height:** The ROI set in SensorROI Selector Set the height.  
You can set an individual height for each ROI. Set it in multiples of 2.
- **SensorROI Offset X:** MultiROI Set the offset in the X direction for each Region.  
The same settings for each ROI. Set it to multiples of 8.
- **SensorROI Offset Y:** The ROI set in SensorROI Selector Set the offset in the Y direction.  
You can set a separate Y-direction offset for each ROI. It can be specified in 2-line units.

#### 4.13.1 Example configuration

Settings	Set value	remarks
SensorROI Enable	True	
SensorROI Mode[ROI0]	On	
SensorROI Width[ROI0]	640	*This is the same width for all ROIs.
SensorROI Height[ROI0]	64	
SensorROI Offset X[ROI0]	128	*Offset X is common for all ROIs.
SensorROI Offset Y[ROI0]	12	
SensorROI Mode[ROI1]	On	
SensorROI Width[ROI1]	640	*This is the same width for all ROIs.
SensorROI Height[ROI1]	128	
SensorROI Offset X[ROI1]	128	*Offset X is common for all ROIs.
SensorROI Offset Y[ROI1]	256	
SensorROI Mode[ROI2]	On	
SensorROI Width[ROI2]	640	*This is the same width for all ROIs.
SensorROI Height[ROI2]	64	
SensorROI Offset X[ROI2]	128	*Offset X is common for all ROIs.
SensorROI Offset Y[ROI2]	512	
SensorROI Mode[ROI3]	On	
SensorROI Width[ROI3]	640	*This is the same width for all ROIs.
SensorROI Height[ROI3]	1000	
SensorROI Offset X[ROI3]	128	*Offset X is common for all ROIs.
SensorROI Offset Y[ROI3]	700	
SensorROI Mode[ROI4]	Off	

SensorROIMode[ROI5]	Off	
SensorROIMode[ROI6]	Off	
SensorROIMode[ROI7]	Off	

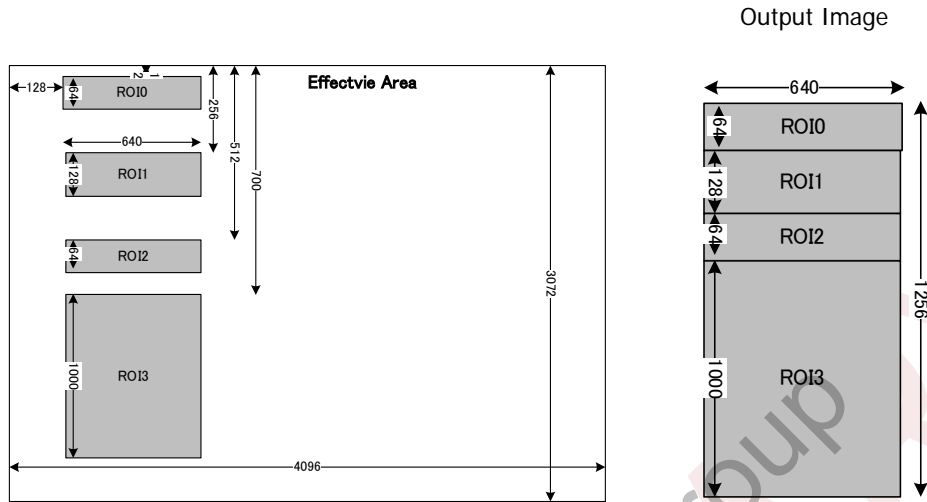

#### 4.14. Binning

- You can set the binning mode (simple addition mode).

ImageFormatControl	
BinningHorizontal	1~2
BinningHorizontalMode	Sum/Average
BinningVertical	1~2
BinningVerticalMode	Sum/Average

• BinningHorizontal: Set horizontal binning to be enabled or disabled.

- 1: Binning disabled
- 2: Binning Enabled

• BinningHorizontalMode: Horizontal binning mode.

Sum: Addition Mode(Output 4 pixels in height and width as 1 pixel). The sensitivity is about 4 times higher.

Average: Average Mode(Output 4 pixels in height and width as 1 pixel). The sensitivity will be the same as usual.

• BinningVertical: Set the vertical binning to be enabled or disabled.

- 1: Binning disabled
- 2: Binning Enabled

• BinningVerticalMode: Vertical binning mode.

Sum: Addition Mode(Output 4 pixels in height and width as 1 pixel). The sensitivity is about 4 times higher.

Average: Average Mode(Output 4 pixels in height and width as 1 pixel). The sensitivity will be the same as usual.

[Note]

- BinningHorizontal, BinningHorizontalMode 1 and BinningVertical, BinningVerticalMode changes should not be

performed during grabbing (during image acquisition).

- The BinningHorizontal and BinningVertical settings are linked.  
If you change one of them, the other will also change to the same setting.
- The BinningHorizontalMode and BinningVerticalMode settings are interlocked.  
If you change one of them, the other will also change to the same setting.
- It cannot be used in conjunction with the ROI feature. Valid only at full scale.
- The frame rate is the same as at full scale.

**4.15. Defect pixel correction**

- This function compensates for "defective pixels" contained in the data output from the sensor.
- Data is managed in two main types.  
Factory data  
It retains white and black defects detected in the factory.  
You can't erase this data.
- User registration data  
If the defect increases after shipment, it can be further compensated.  
DefectPixelDefault allows you to delete user-registered defect data.
- The number of points that can be registered as a user is 512 points. (However, each CH is limited to 64 points.) )

[ CH (Channel) ] The image is processed inside the camera with an 8CH interleave.

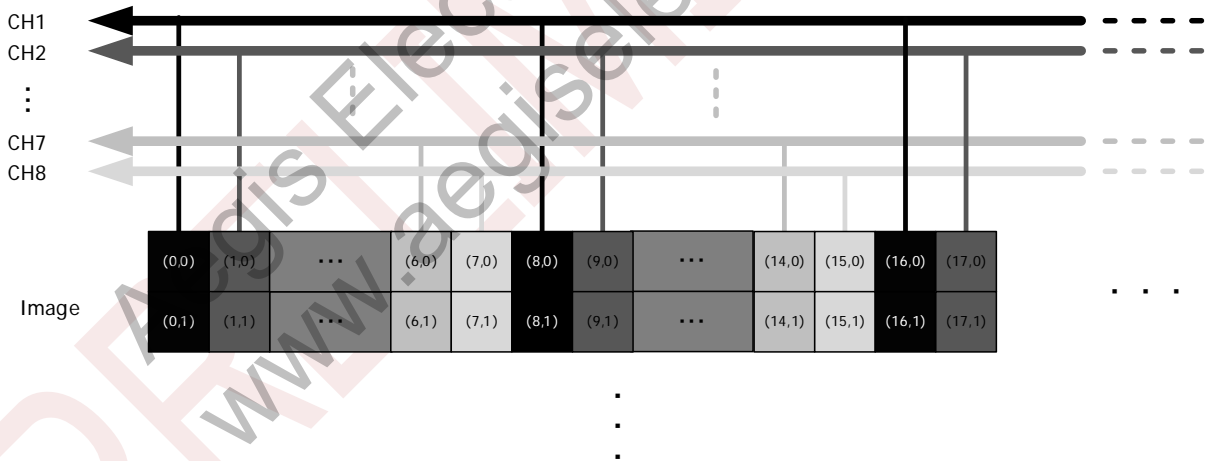

- On/Off Control of Fault Compensation

AnalogControl	
DefectPixelCorrection	On/Off

- ♦ DefectPixelCorrection: Select Enable or Disable Defect Pixel Correction.
  - ※ Please note that factory data and user registration data are not differentiated and both are turned on/off.
  - ※ When enabling MultiROI, set DefectPixelCorrection to Off.
  - ※ If you have the noise filter enabled, please disable it and then set it to Off.

- User registration (coordinate designation)

This function allows you to register and delete any pixel as defective pixels by specifying X and Y coordinates.



As shown in the figure on the left, refer to the pixel values of the top, bottom, left, and right to calculate the X pixel value.

Even if you register a new X while the defective pixels of X1, X2, X3, and X4 are already registered,

X is not compensated.

AnalogControl	
DefectPixelAdd	(Execute)
DefectPixelAddOffsetY	0~4095 [Not eligible for saving settings]
DefectPixelAddOffsetX	0~3071 [Not eligible for saving settings]
DefectPixelDelete	(Execute)
DefectDetectionStatus	(ReadOnly)

- DefectPixelAddOffsetY: Specify the Y coordinate to be registered (Coordinates before binning when binning)
- DefectPixelAddOffsetX: Specify the X coordinate to be registered (Coordinates before binning when binning)
- DefectPixelAdd: The specified coordinates are registered as trapped pixel correction points.
- DefectPixelDelete: Deletes data that has been registered as a defective pixel correction point with the specified coordinates.
  - ※ The DefectPixelDelete command allows you to delete only user-registered (coordinated) data. Factory data cannot be deleted (if you specify the same coordinates as the factory defect data, it will be ignored).
  - ※ When registered with the DefectPixelAdd command, it is not stored in non-volatile memory. If you want to save it to non-volatile memory, run the UserSetSave command.
  - ※ Registration and deletion are limited for MultiROI (feasible for full-size and SingleROI).
- DefectDetectionStatus – Indicates the result of the user-registered defect detection action.

0	User registration defect correction data is not available
Number (512 or less)	Number of user registration defects
Error	
0x000e0001 (917505)	The total number of user registration defect correction data exceeds the maximum number of registrations (512 points).
0x000e0002 (917506)	The maximum number of users can register for a single CH (64) has been

- Delete all user registration information

You can delete the information registered by the user by specifying coordinates or defect detection in bulk with the following command.

AnalogControl	
DefectPixelDefault	(Execute)

- DefectPixelDefault : User registration (Coordinate Designation and Defect Correction) Delete all data.

- Defect Registration Data Display

You can view the information of the registered factory data and user registration data.

AnalogControl
---------------

RegisteredDefectSelector	UserState/InitialState	[Not eligible for saving settings]
RegisteredDefectNumber	(ReadOnly)	
DefectPixelNumber	1~512 (UserState) 1~1536 (InitialState)	[Not eligible for saving settings]
DefectPixelOffsetY	(ReadOnly)	
DefectPixelOffsetX	(ReadOnly)	
DefectPixelType	(ReadOnly)	

- RegisteredDefectSelector — Select the type of data to display:
  - UserState: User registration data
  - InitialState: Factory Data
- RegisteredDefectNumber — Displays the number of defects being corrected.
- DefectPixelNumber : Specifies the number of the defect table that is registered in the selected data.
- DefectPixelOffsetY :DefectPixelNumber displays the Y coordinates of the defect specified in it.
  - If the table number has no defect data, 65535 is displayed.
  - When binning, the coordinates before binning are displayed.
  - ROI displays ROI coordinates.
- DefectPixelOffsetX :Displays the X coordinates of the defect specified by the efectPixelNumber.
  - If the table number has no defect data, 65535 is displayed.
  - When binning, the coordinates before binning are displayed.
  - ROI displays ROI coordinates.
- DefectPixelType :D Indicates the defect type specified by efectPixelNumber.
  - 1: Factory white defect
  - 2: Factory black defects
  - 7: User Addition Registration Defect
  - 65535: Tables without defective data

AnalogControl		
ChannelNumber	1~8	[Not eligible for saving settings]
DefectPixelChannelCount	(ReadOnly)	

- ChannelNumber : Specifies the channel number for defect handling.
- DefectPixelChannelCount — Displays the number of defects for the channel number specified in ChannelNumber. The number of types selected in the RegisteredDefectSelector.

**4.16. Noise Filter**

- This is a function that compensates for pixel defects in real time.
  - Since this feature is used in conjunction with pixel defect correction, the noise filter cannot be set to True when DefectPixelCorrection is off.

PixelCorrectionControl	
ImpulseNoiseFilter	True/False
ImpulseNoiseFilterThreshold	0~4095

- ♦ ImpulseNoiseFilter
  - ♦ If set to False, the noise filter function will not work.
  - ♦ If true, the compensation is applied for the point where the difference between the surrounding and

featured pixels is greater than the value of ImpulseNoiseFilterThreshold.

- ※ Adverse effects of overcorrection may occur. Be sure to check the image before using it.
- ※ If the threshold is set to 4095, it will no longer detect defects.
- ※ Please check the image and adjust the threshold according to your usage.

[Note]

- MultiROI is not supported.

#### 4.17. Shading Correction

- This function compensates for the drop in ambient light caused by lenses and other factors.

AnalogControl	
ShadingCorrectionDataSelector	Off/Table1/Table2/Table3/Table4
DetectShading	(Execute)

- ShadingCorrectionDataSelector :

Shading Off or select the Shading Correction Table to use.

If you select Table1- Table4, the correction function will be turned on for each correction value.

\*MultiROI and shading correction cannot be used together. It can be used in conjunction with SingleROI.

Before Shading Correction

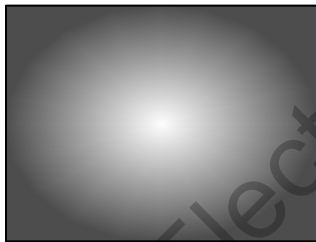

After Shading Correction



- DetectShading :

Table1- You can retrieve correction data to the specified Table by performing DetectShading while selecting Table4.

When a uniform level of subject, such as a pattern box, is imaged on the entire screen and shading detection is performed, shading correction data is automatically calculated. The calculated correction data is stored in the table selected in the ShadingCorrectionDataSelector.

[Note]

- Obtain correction data only while the camera is in operation.  
(Shading correction data cannot be obtained when the camera is not output.)
- When performing shading detection, turn off partial scanning and perform it at full scale.
- When UserSetSave is executed, the correction data of Table1~Table4 is stored in non-volatile memory.
- The compensation data is retained even when Default is run on UserSetLoad.
- When performing a vertical reversal, obtain the shading correction data again.

#### 4.18. Black Level Adjustment

AnalogControl	
BlackOffset	-2048~2047 [-50%~+50%]

- **BlackOffset:** It is a function that adjusts the black level of the sensor.  
This feature does not specify the absolute value of the black level, but rather adjusts relative to it. Set the 12-bit converted number.  
\*Please do not change the values while the image is being acquired.

#### 4.19. Test Pattern Indication

- The camera outputs a test pattern that can be used to check the operation of the system.

ImageFormatControl	
TestPattern	Off GreyScale

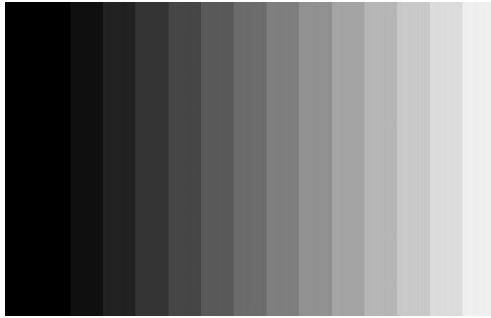

\*Cannot be used in conjunction with the cursor display.

#### 4.20. Cursor Indication

- Display the cursor on the output image.

ImageFormatControl	
CursorPattern	On/Off
CursorOffsetX	0~4095
CursorOffsetY	0~3071
CursorColor	White/Black

- **CursorPattern** : Specifies whether or not the cursor is displayed.
- **CursorOffsetX** : Specifies the X coordinate of the vertical cursor.
- **CursorOffsetY** : Specifies the Y coordinate of the horizontal cursor.
- **CursorColor** : Specifies the color of the cursor. (White/Black)

\*It cannot be used in conjunction with the test pattern display.

[Note]

- When displaying partial (ROI), the cursor coordinates are the origin of (0,0) in the upper left corner of the active area.
- When the displayed image is zoomed out, the cursor may not be displayed.

#### 4.21. LED Operating Modes

- Change the LED behavior on the rear of the camera. Refer to the LED indicator for the lighting pattern.

DeviceControl	
DeviceIndicatorMode	Active ErrorStatus

	Inactive
--	----------

- DeviceIndicatorMode: Choose from three types of LED behavior.
  - Active: CoaXPressDisplay communication status.
  - ErrorStatus: Normally turned off and turned on only when an error occurred.
  - Inactive: The lights are always turned off.

#### 4.22. Temperature Indication

- Displays the value of the temperature register of the camera's sensor.

DeviceControl		
DeviceTemperatureSelector	Sensor FPGA	[Not eligible for saving settings]
DeviceTemperature	(ReadOnly)	

- DeviceTemperatureSelector: Select the temperature measurement location in the camera.
- DeviceTemperature: Displays the temperature of the selected area in ° C.

[Note]

- The readings are not calibrated.

#### 4.23. Camera Timing IO

- The LineSelector and LineSource settings set the input and output of the 6-pin circular connector.

Digital IO Control		
LineSelector	Line0 Line1	[Not eligible for saving settings]
LineMode[LineSelector]	Input Output	
LineSource[LineSelector]	Off FrameTrigger ExposureActive FrameActive LineActive TriggerPacketActive	

- LineSelector: establishment/Select the Line you want to view.
  - Line0: No.3 Pin of 6 Pin Circular Connector
  - Line1: No.5 Pin of 6 Pin Circular Connector
- LineMode: Displays the input/output direction of the selected Line.
  - \* If LineMode=Input is set to TriggerSource, it cannot be changed to Output.
- LineSource: Select the signal for the selected Line from the following:
  - Off : 0 Fixed.
  - FrameTrigger (Input) : Receive a start trigger.
  - ExposureActive (Output) : Hi-active outputs the exposure period of the image sensor.
  - FrameActive (Output) : Outputs the lifetime of the frame with Hi-Active.
  - LineActive (Output) : Outputs the lifetime of the line with Hi-Active.
  - TriggerPacketActive(Output) : Decodes and outputs the uplink trigger packet signal.
  - \* If the LineSource does not match the LineMode (in parentheses above), it will be changed to Off.

**4.24. SourceTag Reset**

DigitalIOControl	
SourceTagReset	(Execute)

- Reset the SourceTag in the image header to 0.

PRELIMINARY  
Aegis Electronic Group  
www.aegiselect.com

## 5. Factory Settings

Feature	Initial Data	Explanation
<b>DeviceControl</b>		
DeviceUserID	""	No user string (16 characters) setting
DeviceUserString	""	No user string (256 characters) setting
DeviceIndicatorMode	Active	LED operating mode CoaXPress communication status display
<b>ImageFormatControl</b>		
PixelFormat	Mono8	monochrome 8bit
RegionSelector	Region0	Partial Region (ROI) Region0 Enabled State
RegionMode	On	Partial Area (ROI) Behavior On
Width	4096	Divided Area (ROI) Horizontal 4096pixel (Full Size)
Height	3072	Partial Area (ROI) Vertical 3072line (Full Size)
OffsetX	0	Partial Area (ROI) Horizontal Start Position 0
OffsetY	0	Partial Region (ROI) Vertical Start Position 0
SensorROIEnable	False	MultiROI Action Off
SensorROISelector	ROI0	
SensorROIMode	Off	
SensorROIWidth	4096	
SensorROIHeight	3072	
SensorROIOffsetX	0	
SensorROIOffsetY	0	
BinningHorizontal	1	Binning mode disabled
BinningHorizontalMode	Average	Binning Average Mode Settings
BinningVertical	1	Binning mode disabled
BinningVerticalMode	Average	Binning Average Mode Settings
ReverseX	False	Left and right flip OFF
ReverseY	False	Flip up and down OFF
CursorPattern	Off	Cursor display off
CursorX	0	X coordinate of vertical cursor = 0
CursorY	0	Horizontal cursor Y vertical = 0
CursorColor	White	Cursor Color = White
TestPattern	Off	Test Pattern Display Off
<b>AcquisitionControl</b>		
TriggerSelector	AcquisitionStart	Internal Sync Mode (Freerun)
TriggerMode	Off	Internal Sync Mode (Freerun)
TriggerSource	LinkTrigger0	CXP UpLink Triggers
TriggerActivation	RisingEdge	
ExposureTime	21588	Exposure Time 21588 $\mu$ s
AcquisitionFrameRate	46.008743286132 81	Frame rate @ CXP6 Mono8
<b>AnalogControl</b>		
Gain	1.000	Gain 1.00x
Gamma	1.0	Gamma correction value 1.00
BlackOffset	0	Black Level Default
ShadingCorrectionDataSelector	Off	Shading Correction Off
ImpulseNoiseFilter	False	Noise Filter OFF
ImpulseNoiseFilterThreshold	4095	Noise Filter Threshold

<b>PixelCorrectionControl</b>		
DefectivePixelCorrection	On	Defect pixel correction On
DefectivePixelAddOffsetX	0	Specify the X coordinate of the correction pixel = 0
DefectivePixelAddOffsetY	0	Y coordinate designation of correction pixel = 0
DefectivePixelThresholdValue	4095	Threshold for defect pixel detection
<b>TransferControl</b>		
CxpLinkConfiguration	CXP6_X1	CXP-6 (6.25Gbps), 1 link
<b>DigitalIOControl</b>		
LineMode[Line0]	Input	No. 3 Pin Trigger Input of 6-Pin Circular Connector
LineMode[Line1]	Output	No. 5 Pin Trigger Output of 6-Pin Circular Connector
LineSource[Line0]	Off	No.3 Pin Trigger Input of 6 Pin Circular Connector Off
LineSource[Line1]	Off	No.5 Pin Trigger Output of 6 Pin Circular Connector Off

**6. Dimensios**

**6.1. Camera Dimensios**

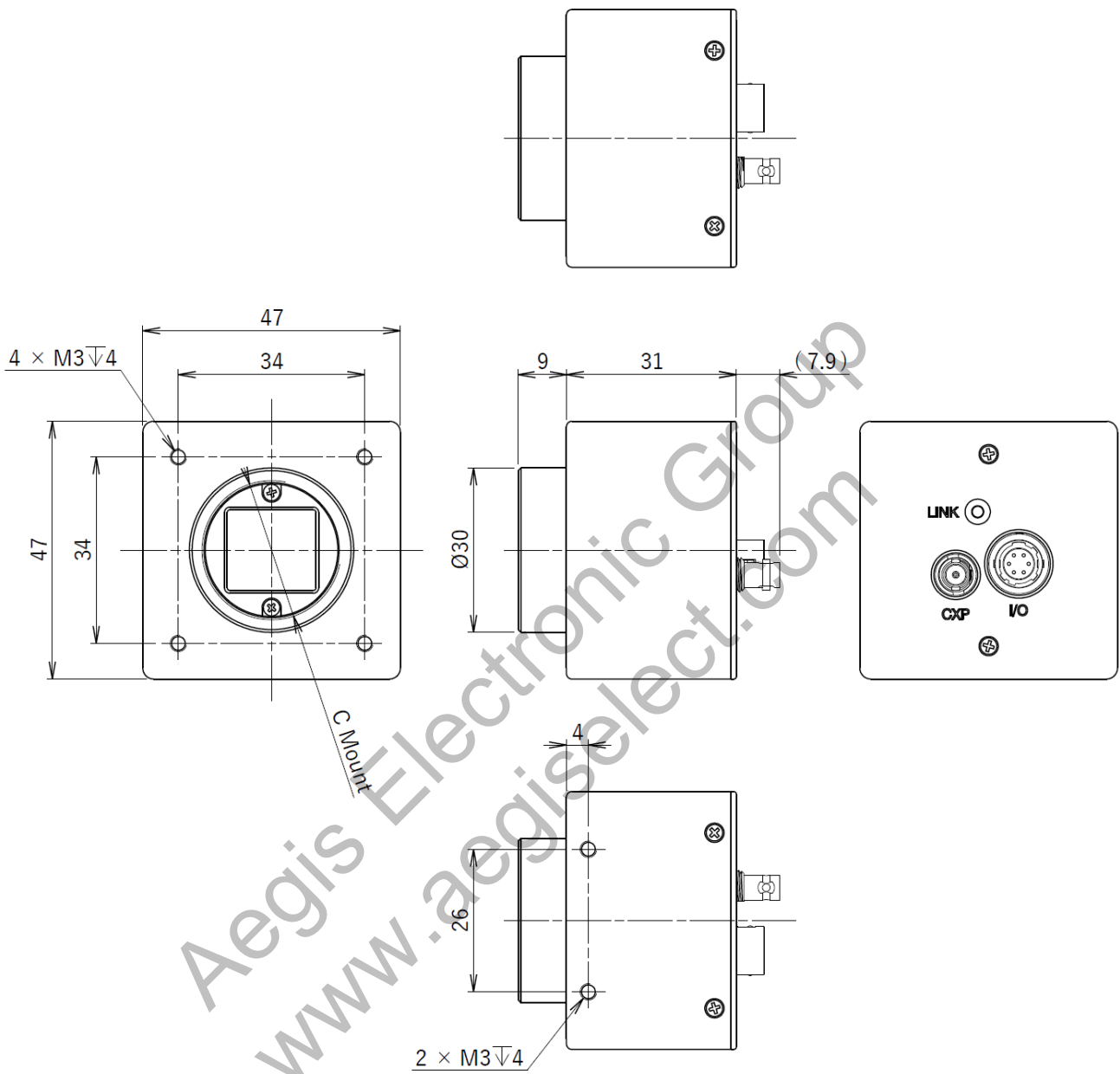

6.2. Optical Axis Accuracs

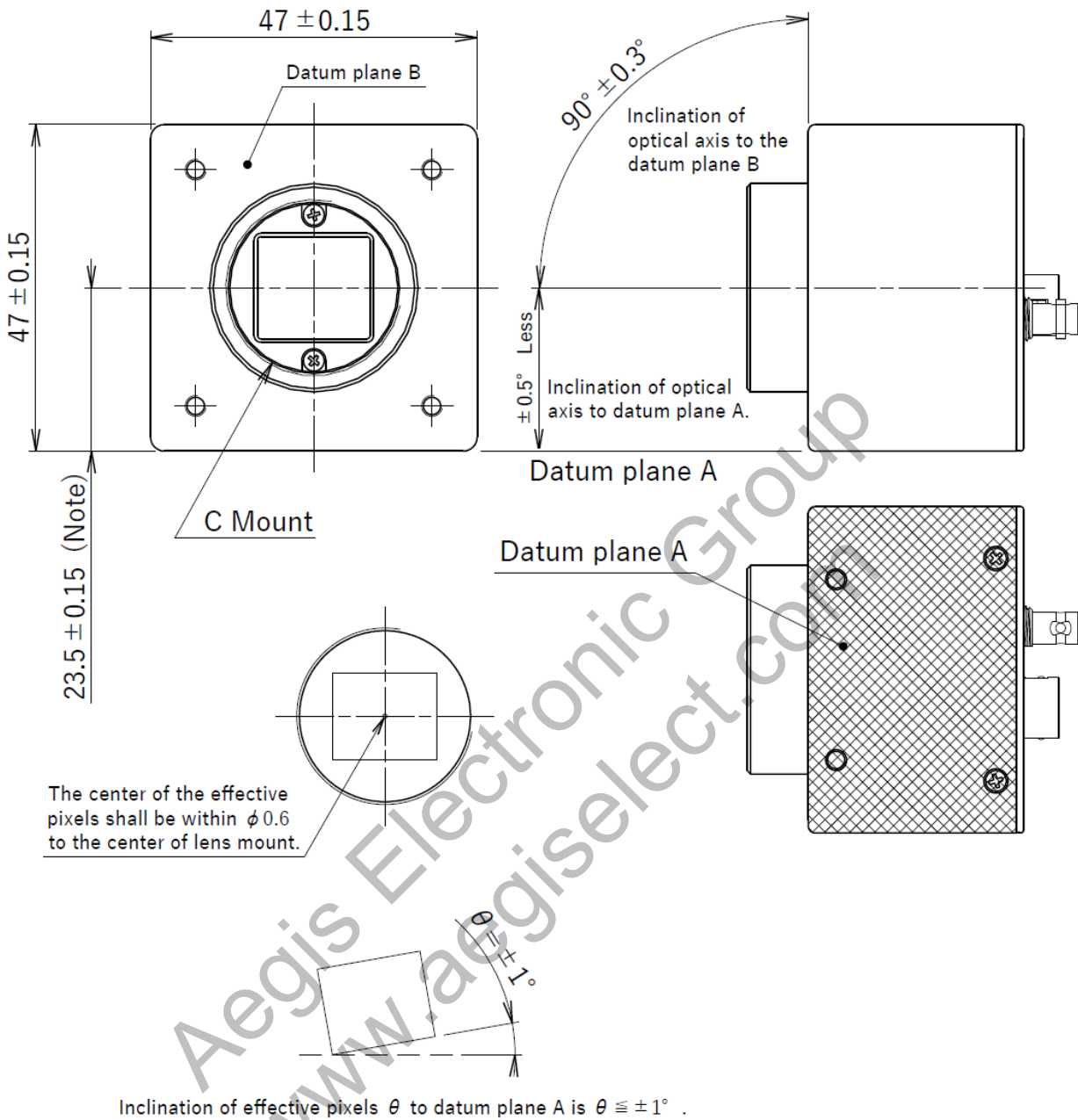

Note:Dimensions from datum plane A to the center of the lens mount.

937-0046-00  
(Unit : mm)

## **7. Case for Indemnity (Limited Warranty)**

### **7.1. Product Warranty**

The warranty period of this product is 3 years from the date of shipment from our company.

During this period, if a malfunction occurs due to our design or manufacturing, we will repair it free of charge in accordance with the product service in clause 7.3.

However, damage or breakdown caused by the customer's negligence in handling, or natural disasters such as fire, earthquake, lightning strike, storm and flood damage, or force majeure is not covered by the warranty.

Repairs after the warranty period has expired will be repaired for a fee if repaired is possible.

### **7.2. CMOS pixel defects.**

At the time of shipment, noticeable pixel defects are corrected and shipped, but after the product is shipped, new pixel defects may occur due to the unique characteristics of the imaging sensor, and some defect levels may increase over time. These are excluded from the product warranty.

For details of pixel defect correction, please contact our sales department.

### **7.3. Product Support**

If the product does not work properly due to any factor after purchasing the product, please contact the dealer where you purchased it for investigation, analysis, and repair.