

CIS

CoaXPress I/F

5M Visible + SWIR Wideband Camera

VCC-5CXP1SW

Product Specifications

(Preliminary)

CIS Corporation

Table of Contents

1. Handling Precautions	1
1.1. Notes	1
1.2. Restrictions on Applications	1
1.3. Disclaimers	1
1.4. Image Quality Limitations	1
2. Product outline	2
2.1. Features	2
2.2. Bundled Items	2
3. Specifications	3
3.1. General Specifications	3
3.2. Input/Output Specifications	4
3.2.1 TRIGGER_IN (6-pin connector, 3-pin or 5-pin)	4
3.2.2 Signal_out (6-pin connector, 3-pin or Pin 5)	4
3.3. External Connector Pin Assignment	6
3.3.1 6-pin circular connector (I/O)	6
3.3.2 75 Ω Micro BNC Connector	6
3.3.3 LED Indicator	6
3.4. Spectral Response	8
3.5. Frame rate	9
3.5.1 Frame rate in internal sync mode	9
3.5.2 Frame rate in external trigger mode	9
4. Camera Features	10
4.1. How to set it up	10
4.2. Device Information	10
4.2.1 Camera Information	10
4.2.2 User Information	10
4.3. Saving and Initializing Settings	10
4.4. Link speed and number of links	12
4.5. Pixel format	12
4.6. Flip	12
4.7. Trigger Mode	14
4.7.1 Internal synchronization mode (freerun mode)	14
4.7.2 External trigger mode	15
4.7.3 Fixed Trigger Shutter Mode + H-sync trigger (LineSync)	16
4.7.4 Fixed Trigger Shutter Mode + CLK sync triggers (ClockSync)	18
4.7.5 Pulse Width Trigger Shutter Mode + H-Sync Trigger (LineSync)	19
4.7.6 Pulse Width Trigger Shutter Mode + CLK Sync Trigger (ClockSync)	21
4.7.7 External trigger input prohibition timing	22
4.8. Exposure Time	24
4.8.1 Manual shutter calculation formula when triggering H Sync (LineSync)	24
4.8.2 Manual shutter setting in CLK Sync mode	24
4.9. Gain	24
4.10. Sensor Black Level Adjustment	25
4.11. Partial Scan (SingleROI)	25
4.12. Partial Scan (MultiROI)	25
4.13. 2x2 binning mode	27
4.14. Pixel defect correction	29
4.15. Noise Filter	31
4.16. Test Pattern Display	32

4.17.	Cursor display.....	32
4.18.	LED Operating Modes.....	32
4.19.	Camera Timing I/O.....	32
4.20.	Save User ID.....	33
4.21.	Temperature display.....	34
4.22.	Connection Reset.....	34
4.23.	Gamma correction.....	34
4.24.	Image quality selection mode.....	35
4.25.	Shading Correction.....	35
5.	Factory Settings.....	37
6.	Dimensions.....	39
6.1.	External Dimensions.....	39
6.2.	Optical Axis Accuracy.....	40
7.	Case for Indemnity.....	41
7.1.	Product Warranty.....	41
7.2.	CMOS Pixel Defect.....	41
7.3.	Product Support.....	41

1. Handling precautions

1.1. Notes

- For camera protection, do not use in dusty or humid areas.
- Please handle the camera with great care to avoid strong impact or static electricity. It can cause a breakdown.
- To protect the CMOS image sensor, please do not directly image direct sunlight or high-brightness lights. Also, when not in use, please wear a protective cap.
- Connect to the camera in accordance with "3.3. External Connection Connector Specification". Please note that incorrect connections can not only damage the camera itself, but also cause irreparable failure to the connected equipment.
- If there is an AC leak from the device connected to the camera (monitor/computer, etc.), the camera may be broken. Please check the ground potential between each other and make sure that there is no problem before connecting.
- The power supply voltage of the camera should be used correctly within the specifications. If you use a power supply that does not meet the specifications or is unstable, the camera may malfunction or malfunction.
- All camera failures or malfunctions caused by incorrect use without following the above precautions are not covered by the product warranty.

1.2. Restrictions on Applications

- This product is not designed and manufactured with the consideration that it will be used in devices that are directly related to human life, devices that may harm the human body, the space industry, etc., and should not be used for those applications.
- Please avoid using it under conditions or environments other than those specified, especially in applications where safety is required, or contact us.
- This product is prohibited from use for military-related purposes by the List Regulations.

1.3. Disclaimers

- Damage or breakdown caused by earthquakes, lightning, floods, fires, or other force majeure is not covered by the warranty.
- Damage caused by the customer's negligence or damage caused by failure to comply with the contents of this specification is not covered by the warranty.
- Failures caused by repairs or modifications made by customers other than our company are not covered by the warranty.

1.4. Image Quality Limitations

This product has different image quality characteristics from ordinary silicon sensors. Please refer to the "Appendix: 5CXP1SW image quality and other points to note" at the end of the book and use it based on its characteristics.

2. Product Outline

The VCC-5CXP1SW is a CoaXPress output camera using a 1/1.4-inch 5-megapixel visible+SWIR wideband image sensor.

2.1. Features

- Enclosure 65mm x 65mm x 65mm size
- Global shutter system Visible + SWIR sensor
- CoaXPress CXP-6/CXP-12
- 1 lane
- PoCXP support
- Maximum cable length 24m (CXP-12), 40m (CXP-6)
- ROI/Multi-ROI
- Binning addition and average
- Exposure, Gain Settings
- External trigger mode (fixed trigger shutter mode / pulse width trigger shutter mode)
- Compliant with CoaXPress standard (GenICam support)
- C-mount

2.2. Bundled Items

- Standard configuration
 - Camera body

3. Specifications

3.1. General Specifications

Electrical Specifications			
Pixel sensor	Imaging Devices	1/1.4" Global Shutter Visible + SWIR	
	Effective number of pixels	2592(H) × 2056(V)	
	Pixel size	3.45μm(H) × 3.45μm(V)	
Video Output Mode		Ver,1.1.1 complied, CXP6_X1 / CXP12_X1	
Video Output Format		Mono8 / Mono10 / Mono12	
Frame rate	CXP6 8bit/10bit/12bit	105.14fps/80.69fps/68.03fps	
	CXP12 8bit/10bit/12bit	(Repealed) 131.92fps/120.89fps/70.95fps	
Synchronous method		Internal synchronization	
Video output pixel size (maximum pixel size)		2592 (H) × 2056(V)	
Video Signal (Gain 0dB)	White clip level	255digit	MONO8bit
	Setup Levels	0~1digit	At MONO8bit, at factory settings
	Dark Shading	0~6 digit (H/V)	At MONO8bit, at factory settings
Standard Sensitivity		TBD	
Minimum subject illumination		TBD	
Gain variable Range		x1~x8 (0dB~18dB)	
Shutter speed		16[μs]~200,000[μs]	
Gamma correction		Yes (γ=0.1~2.2)	
Trigger-Mode		Freerun mode (internal camera trigger) Trigger Mode (Host, External Terminal) Fixed trigger shutter Pulse width trigger shutter	
Partial Scan		8 areas (max), vertical & horizontal variable size (However, horizontal offsets are common across all ROIs.)	
Supply voltage		PoCXP: 18.5~26V	
Power consumption		4.2 W (CXP12) [Freerun]	
Mechanical Specifications			
Dimensions		H: 65mm W: 65mm D: 65mm excluding protrusions	
weight		TBD g	
Lens mount		C-mount	
Environmental Specifications			
Safety/Quality standard		CE (to be obtained) EMC 2014/30/EU Conformity Standard Emission: EN61000-6-4:2007+A1:2011 Immunity: EN61000-6-2:2019 IEC61000-4-5 (surge) is not applicable. If the cable length is longer than 30 m or if the wiring is to be done outdoors Use a surge protector to prevent surge contamination.	
		RoHS 2011/65/EU (EU)2015/863 Conform to EN50581(RoHS2)	
Durability	Vibration	Acceleration	: 98m/s ² (10G)
		Frequency	: 20 ~ 200Hz
		Direction	: X, Y, Z 3 directions
		Testing time	: 120 points in each direction
	Shock	No malfunction shall occur with the maximum 980 m/s ² (100) G for	

		±X, ±Y, and ±Z 6 directions without packing.
Operation guaranteed temperature	0 ~ +45°C	Humidity 20 ~ 80%RH with no condensation.
Storage Temperature	-25 ~ +60°C	Humidity 20 ~ 80%RH with no condensation.

3.2. Input/Output Specifications

3.2.1 TRIGGER_IN (6-pin connector, pin 3 or pin 5))

- Open Collector Input
- You can enter triggers directly from external devices.

If you want to use this terminal, set the following:

- Set the LineSelector of the DigitalIOControl to Line0 (pin 3) or Line1 (pin 5).
- Set DigitalIOControl's LineMode to Input.
- Set DigitalIOControl's LineSource to FrameTrigger.
- Set AcquisitionControl's TriggerSource to LineSelector.

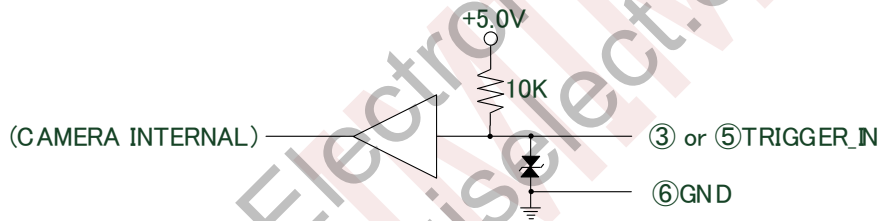

3.2.2 Signal_out(6-pin connector , pin 3 or pin 5)

- Open collector output
- It can output the timing signal inside the camera.

If you want to use this terminal, set the following:

- Set the LineSelector of the DigitalIOControl to Line0 (pin 3) or Line1 (pin 5).
- Set DigitalIOControl's LineMode to Output.
- Set to signal to output DigitalIOControl's LineSource.

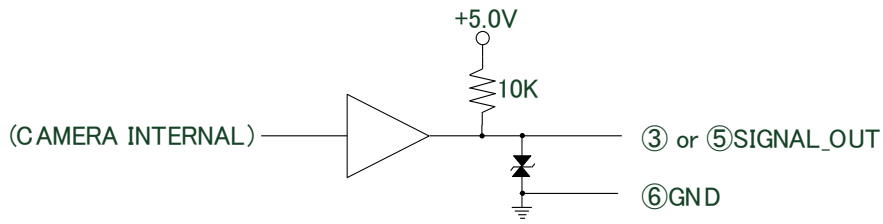

PRELIMINARY
Aegis Electronic Group
www.aegiselect.com

3.3. External Connector Pin Assignment

3.3.1 6-Pin Circular Connector (I/O)

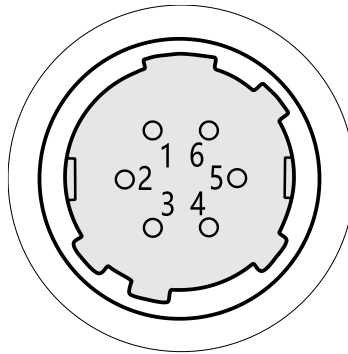

HR10-7R-6PA(Hirose or equivalent)

Pin Number	Signal Name	remarks
1	NC	
2	NC	
3	Line0	TRIGGER_IN SIGNAL_OUT (Exposure/FVAL/LVAL/LinkTrigger 選択出力)
4	NC	
5	Line1	TRIGGER_IN SIGNAL_OUT (Exposure/FVAL/LVAL/LinkTrigger 選択出力)
6	Common	TRIGGER_IN. Return of SIGNAL_OUT (common)

*NC = Non-Connection . Do not connect anything to the terminals.

3.3.2 75 Ω Micro BNC Connector

- This is the image output signal of CoaXPress.
- PoCXP is supported.

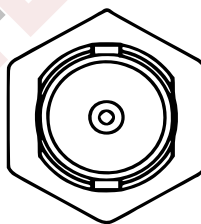

3.3.3 LED Indicator

- When DeviceIndicatorMode is Active, the emission state indicates the state of the camera.

LED status	Camera Status
off	No power supply
Green/Orange Fast Flashing [12.5Hz]	No cable connected
Green Lighting	Device and host connection established
Green Fast Flashing [12.5Hz]	During video data transfer
Orange Low flashing [1Hz]	Waiting for trigger input

Red Fast Flashing [12.5Hz]	Image Transfer Error Occurs, Incorrect Trigger Detected [Error]
----------------------------	-----------------------------------------------------------------

*If an incorrect trigger is detected while using the external trigger synchronization mode, an error will be displayed.

PRELIMINARY
Aegis Electronic Group
www.aegiselect.com

3.4. Spectral Response

* Excludes lens characteristics, IR cut filter characteristics, and light source characteristics.

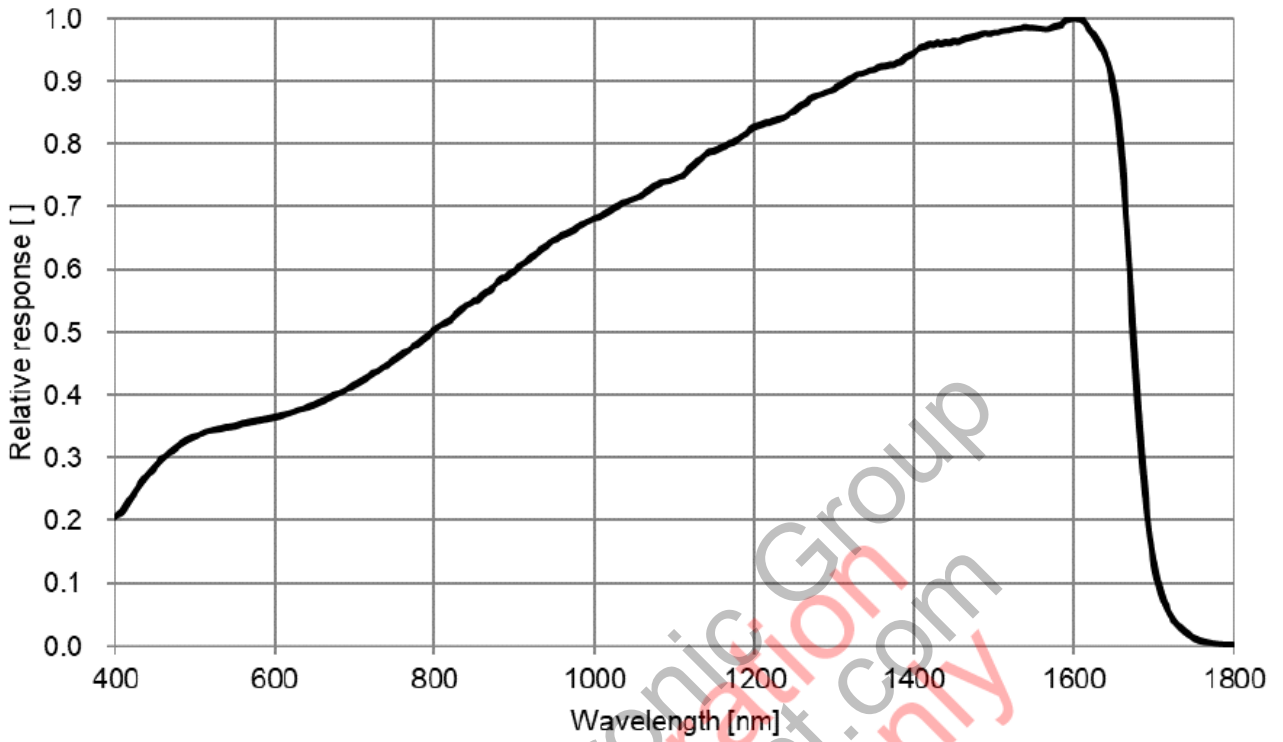

3.5. Frame rate

3.5.1 Frame rate in internal sync mode

H-Sync Trigger (Linesync)

The frame rate can be calculated using the following formula.

$$\text{Frame rate} = 1 / (1 \text{ line time} \times (\text{Number of output image lines} + 84)) \text{ [fps]}$$

Please refer to the table below for the time of one line and the frame rate values for full-frame output.

* Frame rate at full frame = 1/(time for 1 line x (2056+84)).

ConnectionConfig	PixelFormat	1 line time [μs]	When full-size Frame rate [fps]	When full-size Frame Time [ms]
CXP12_X1	Mono8	3.542087542	131.9249494	7.58006734
	Mono10	3.865319865	120.8928978	8.271784512
	Mono12	6.585858586	70.95350037	14.09373737
CXP6_X1	Mono8	4.444444444	105.1401869	9.511111111
	Mono10	5.791245791	80.68898066	12.39326599
	Mono12	6.868686869	68.03188565	14.6989899

The time and frame rate values for one line at 2x2 binning output are the same as above.

You can also read the frame rate during internal synchronization with the following command.

AcquisitionControl	
AcquisitionFrameRate	(ReadOnly)

- ♦ AcquisitionFrameRate : Displays the frame rate in internal synchronization mode (freerun mode).
- *Even in external trigger mode, the frame rate in internal sync mode is displayed.

CLK Sync Trigger (ClockSync)

The frame rate can be calculated using the following formula. Therefore, the frame rate corresponding to the exposure market value is uniquely determined.

$$\text{Frame rate} = 1 / (\text{Exposure Time} - 14.802\mu\text{s} + (1 \text{ line time} \times (\text{Number of output image lines} + 84))) \text{ [fps]}$$

3.5.2 Frame rate in external trigger mode

The fastest frame rate for both H sync triggers (LineSync) and Clk sync triggers (ClkSync) is the same as the above internal sync values.

- *The trigger input should be a period below the highest frame rate above.
- *The time of the 1st line is "3.5.1.Frame Rate in Internal Sync Mode.
- *For details on the external sync mode, please refer to "4.6.2 External Trigger Mode.

4. Camera Features

4.1. How to set it up

- Complies with the CoaXPress standard.

Each configuration item name complies with the GenICam Standard Features Naming Convention (SFNC).

The

corresponding SFNC versions can be obtained in DeviceSFNCVersionMajor, DeviceSFNCVersionMinor, and DeviceSFNCVersionSubMinor.

4.2. Device Information

4.2.1 Camera Information

DeviceControl	
DeviceModel	ReadOnly
DeviceVersion	ReadOnly
DeviceFirmwareVersion	ReadOnly
DeviceSerialNumber	ReadOnly

- DeviceModel : Camera model name
- DeviceVersion : Circuit version
- DeviceFirmwareVersion : Firmware Versions
- DeviceSerialNumber : Camera Serial No.

TransferLayerControl		
DeviceTapGeometry	Geometry_1X_1Y	ReadOnly

4.2.2 User Information

DeviceControl	
DeviceUserID	Manual
DeviceUserString	Manual

You can set a string (including NUL characters (¥0)) for the DeviceUserID and up to 256 characters for the DeviceUserString for the camera. When you run "UserSetSave", it is stored in the non-volatile memory in the camera.

- Regardless of the UserSetSelector, it is a setting in the camera.
- Running UserSetLoad with UserSetSelector=Default maintains the current settings.

When launched with UserSetDefault=Default, it reads out the saved settings.

4.3. Saving and Initializing Settings

- This is a function that stores the operating settings in the camera's non-volatile memory and loads the settings in the non-volatile memory.

UserSetControl		
UserSetSelector	Default UserSet0 UserSet1 UserSet2	[Not eligible for saving settings]
UserSetLoad	Execute	

UserSetSave	Execute	
UserSetDefault	Default UserSet0 UserSet1 UserSet2	

- ♦ UserSetSelector : Select the setpoint in non-volatile memory to store or read the current setpoint
 - Default : Factory Initial Settings (UserSetLoadOnly executable. UserSetSave is not executable)
 - UserSet[0-2] : User Settings
 - ※ The Default area has the default settings, so you cannot save any settings.
 - ※ The value of the UserSetSelector cannot be saved even if you run UserSetSave. It will always be Default at startup.
 - Select UserSetLoad or UserSetSave each time you run.
 - ♦ UserSetLoad :UserSetSelectorLoad the stored settings from the selected area in the Load
 - When the UserSetSelector is Default, it reads out the factory settings.
 - CxpLinkConfiguration, PixelFormat, DeviceUserID, DeviceUserString, UserSetDefault, Defective pixel correction values, and Shading correction values retain their settings.
 - ♦ UserSetSave :Saves the current settings in the user settings area. UserSetSelectorUserSet[0-2].
 - When Default is selected, only UserSetLoad is enabled, and UserSetSave is not possible.
 - ♦ UserSetDefault : Select the settings when the camera starts up.
 - Load the selected settings and the camera will start.
 - Even if you select Default, DeviceUserID, DeviceUserString, defect pixel correction, shading correction, and boundary correction value will read the saved settings.
- UserSetDefault stores the settings immediately when set.
 - UserSetLoad should not be run while grabbing (fetching images).
 - After running UserSetLoad, the camera changes the set value to the Loaded value. However, the display of commands may not be updated depending on the display software you use, so please update the commands.
 - Defective pixel correction value, DeviceUserID, and DeviceUserString retain their current values even when performing a default UserSetLoad.
 - Even after executing UserSetLoad, ConnectionConfig, PixelFormat, and ImageQualityMode will retain their current settings.
 - The following settings have a single storage area and do not depend on UserSet0, 1, and 2, but are saved with UserSetSave.
 - UserSetDefault, DeviceUserID, DeviceUserString, Defective pixel correction values, Shading correction values, boundary correction value

The combination for saving and performing the invocation of the settings is as follows:

UserSetSelector	UserSetLoad/Save	state
Default	UserSetLoad	Factory Settings Call
	UserSetSave	- (Cannot be executed)
UserSet[0-2]	UserSetLoad	User Settings Call
	UserSetSave	User Settings Save

4.4. Link speed and number of links

Transfer Control	
CxpLinkConfiguration	CXP6_X1 CXP12_X1

- CXP6_X1: Link speed=6.250Gbps, Link count=1
- CXP12_X1: Link speed=12.50Gbps, Link count=1

* Do not change the CxpLinkConfiguration while grabbing (while acquiring images).

4.5. Pixel format

ImageFormatControl	
PixelFormat	Mono8 Mono10 Mono12

- PixelFormat: Choosing a pixel format
 - Mono8: monochrome8-bit
 - Mono10: monochrome10-bit
 - Mono12: monochrome12-bit

* Do not change the PixelFormat while grabbing (while acquiring an image).

4.6. Flip

ImageFormatControl	
ReverseX	True/False
ReverseY	True/False

- ReverseX: Flip the image in the X direction
- ReverseY: Flip the image in the Y direction

* Do not change ReverseX/Y while grabbing (while acquiring images).

* When used in conjunction with ROI, the origin coordinate (0) of OffsetY is displayed on the display screen, regardless of the inversion On/Off.

The coordinates associated with the order of setting ReverseY and ROI are shown below.

• Reversal of ROI state

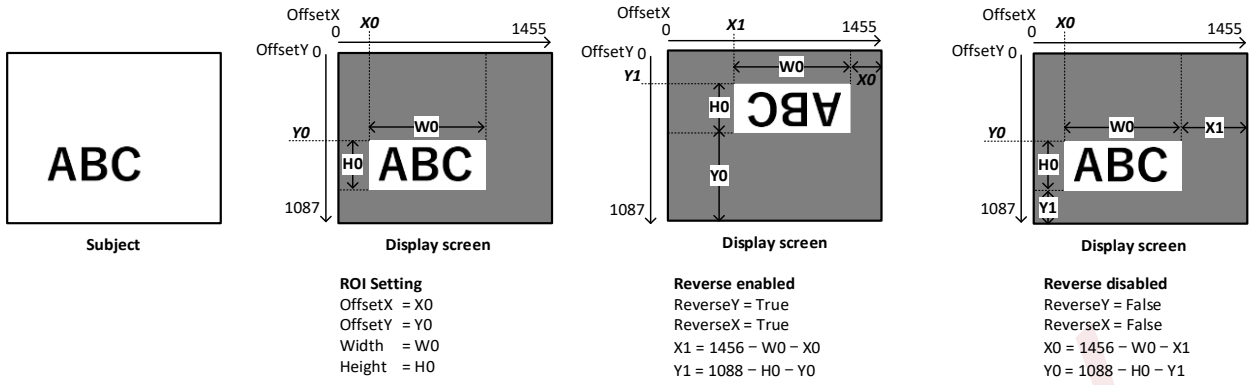

• ROI in reversed state

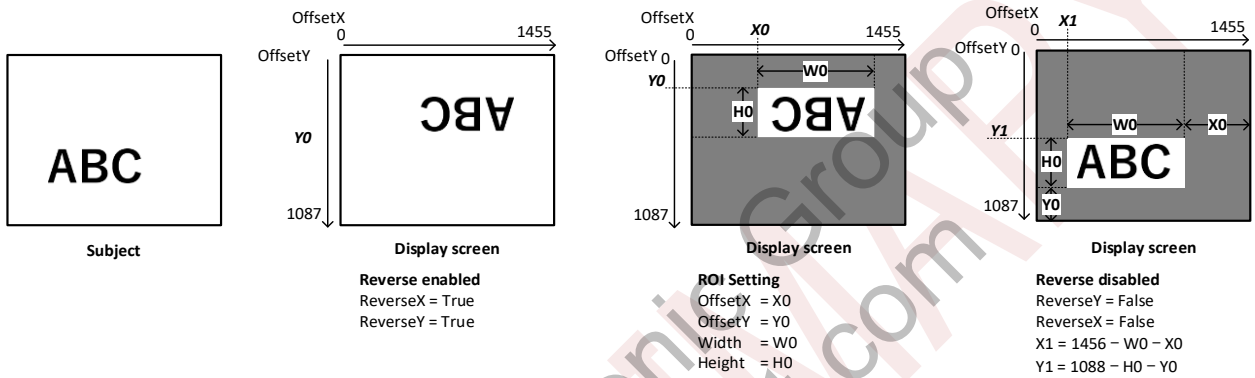

4.7. Trigger Mode

There are two trigger modes: internal synchronization mode and external trigger mode. You can select it with the following command:

Acquisition Control	
TriggerMode	Off/On
TriggerSelector	AcquisitionStart FrameStart

- TriggerMode: Trigger Mode (TriggerSelectorlinked to it)
 - Off: It works in internal synchronization mode (free run mode). (TriggerSelector = AcquisitionStart)
 - On: It works in external trigger mode. (TriggerSelector = FrameStart)

*Do not change TriggerMode while grabbing (while acquiring images).
- TriggerSelector:Trigger Selector (TriggerModelinked to it)
 - AcquisitionStart: Works in internal synchronization mode (free run mode). (TriggerMode = Off)
 - FrameStart: Works in external trigger mode. (TriggerMode = On)

*Do not change the TriggerSelector while grabbing (while capturing an image).

4.7.1 Internal synchronization mode (freerun mode)

- This mode does not require external trigger input, but reads out the video using a trigger that is continuously created inside the camera.
- Set TriggerMode to Off and TriggerSelector to AcquisitionStart.
- If SensorSyncMode is selected as ClockSync, the Exposure Time and Effective Line are automatically set so that they do not overlap.
- The frame rate is "3.5.1. See Frame Rate in Internal Sync Mode.
- The exposure time is set with the ExposureTime command. 「4.7. Exposure Time.
- The timing chart and timing parameters in internal sync mode are shown below.

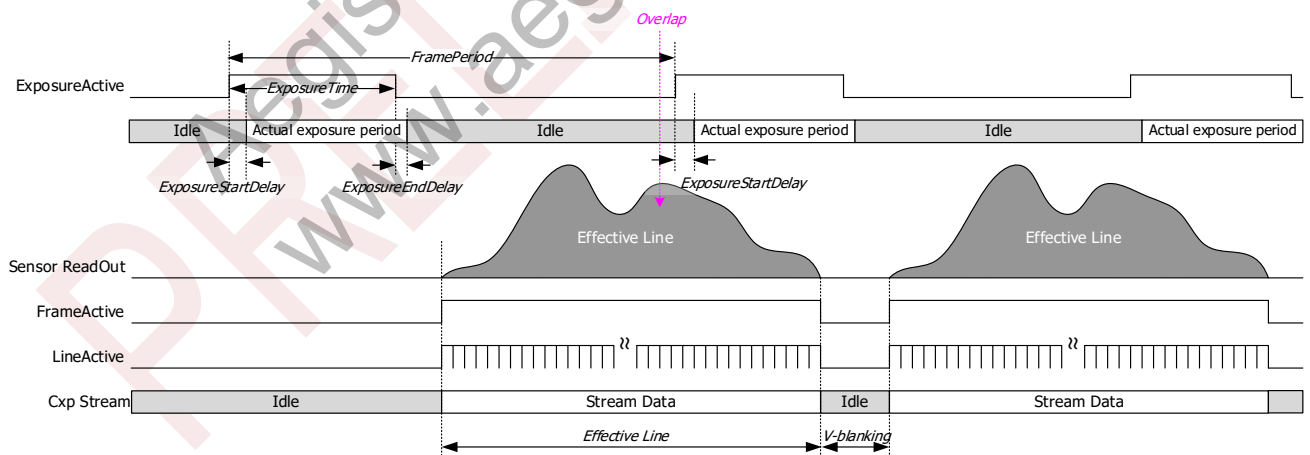

Vertical Sync Timing Chart (Freerun) TriggerMode=Off

Timing Parameter	Value	Description
ExposureStartDelay	2~4	Delay time from ExposureActive rise to start of exposure inside the sensor [H]
ExposureEndDelay	2H +14.802~4H +14.802	Delay time from exposureActive descent to completion of exposure inside the sensor [μ s]
V-blanking	84	Number of Vertical Blanking Lines [H]

*The time of 1 hour is "3.5.1. See the time on one line in the section "Frame rate in internal sync mode".

4.7.2 External trigger mode

- This mode captures the video at any time by inputting a trigger signal.
- Set TriggerMode to On and TriggerSelector to FrameStart. When off, it is in internal sync mode.
- You can select advanced functions by using the following commands: (When selecting a function, please do it with the trigger input stopped.)

Acquisition Control	
SensorSyncMode	LineSync ClockSync
TriggerSource	LinkTrigger0 Line0 Software
TriggerSoftware	(Execute)
TriggerActivation	RisingEdge FallingEdge LevelHigh LevelLow

- **SensorSyncMode:** Specify the synchronization mode for the trigger.
 - LineSync:** H Synchronous Trigger Mode (Exposure time controlled by line)
 - *Overlapping operation (exposure during image readout) enables high frame rate operation.
 - *Due to H synchronization, there is a possibility that one line of jitter may be generated for the external trigger input.
 - ClockSync:** CLK Synchronous Trigger Mode (Controls Exposure Time by Sensor Clock)
 - *Overlapping operation (exposure during image reading) is not possible.
 - *For CLK synchronization, exposure operation can be started with low latency for external trigger inputs.
- **TriggerSource:** Trigger Source Select (External trigger input destination).
 - LinkTrigger0:** Enter the trigger from the CoaXPress Host Device
 - *For how to generate triggers, please refer to the specifications of the Host Device (grabber board, etc.).
 - Line0:** Enter the trigger from the 6-pin circular connector.
 - Software:** Enter a trigger in the TriggerSoftware command.
 - *You can select Software only when the TriggerActivation is RisingEdge.
- **TriggerSoftware:** Issue a software trigger. Generate a trigger inside the camera and shoot one frame. This can only be done when TriggerSource is set to Software.
- **TriggerActivation:** Trigger Activation (Mode or polarity to start video capture).
 - RisingEdge:** Fixed Trigger Shutter Mode: Start exposure at the rising edge (Timed)
 - FallingEdge:** Fixed Trigger Shutter Mode: Start Exposure at Falling Edge (Timed) (※)
 - LevelHigh:** Pulse Width Trigger Shutter Mode: Exposure during High Active Period (TriggreWidth)
 - LevelLow:** Pulse Width Trigger Shutter Mode: Exposure during Low Active Period (TriggreWidth)

(※)

*If you set FallingEdge and LevelLow when setting LinkTrigger0, the image may be disturbed at the start of the first grab after setting. Please be careful when using it.

Trigger Mode Combination

*Please refer to the next section for details of each combination.

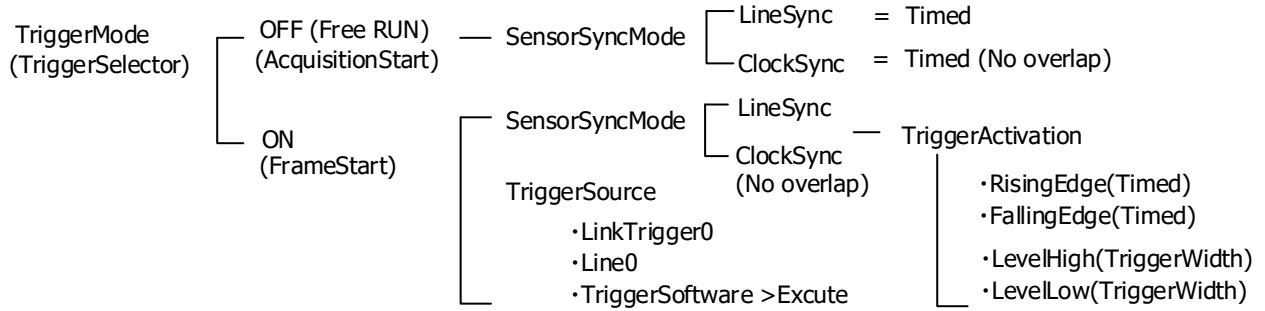

4.7.3 Fixed Trigger Shutter Mode + H-Sync Trigger (LineSync)
 (TriggerMode=On , SensorSyncMode=LineSync , TriggerActivation= RisingEdge)

□ This mode starts the exposure with an external trigger input and performs the exposure at the time set in the ExposureTime command "Section 4.8".

□ The trigger is captured synchronously to H in the camera. Because the following trigger can be entered during image reading (=Overlap)

It can operate at high speeds. However, please note that H-synchronous acquisition will cause 1 hour of jitter in the exposure timing.

□ The frame rate (= trigger input period) is set to "3.5.2.Frame rate in external trigger mode or less than the fastest frame rate listed in the section

Please make it to.

□ There are restrictions on trigger input, so please refer to "4.6.7. Please refer to "When to prohibit external trigger input".

□ The timing chart and timing parameters in this operating mode are shown below.

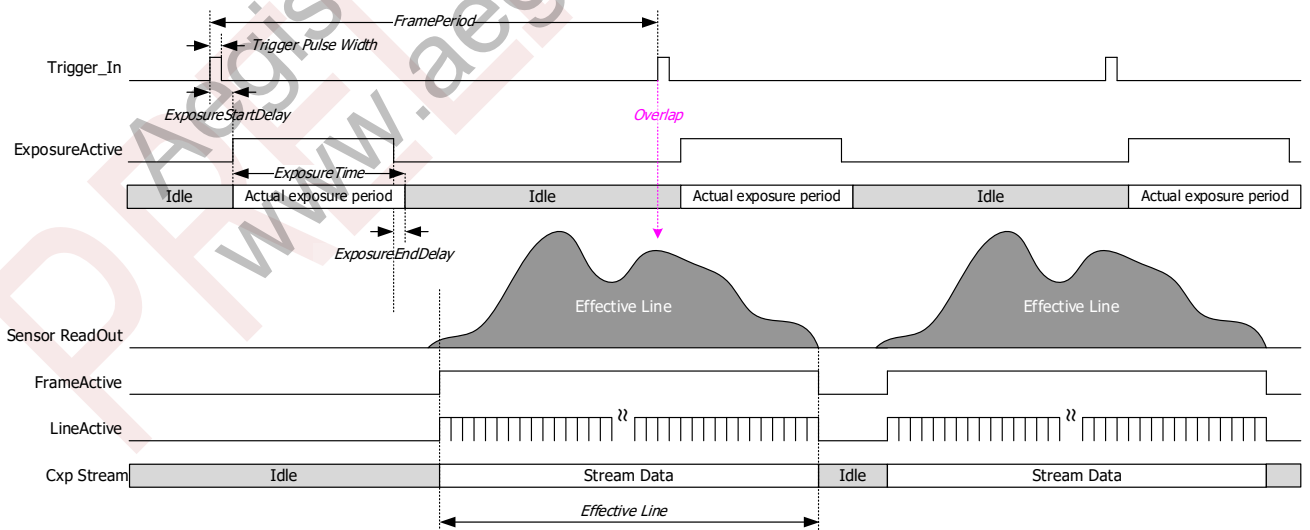

Vertical Sync Timing Chart (Fixed Trigger Shutter Mode + H-Sync Trigger (LineSync))

Timing Parameter	Value	Description
Trigger Pulse Width	1	Trigger Input Pulse Width (Min) [H]
ExposureStartDelay	2 ~ 4	Delay time from ExposureActive rise to start of exposure inside the sensor [H]

ExposureEndDelay	2H +14.802~4H +14.802	Delay time from ExposureActive descent to completion of exposure inside the sensor [μ s]
------------------	-----------------------------	-----------------------------------------------------------------------------------------------

*The time of 1 hour is "3.5.1. See the time on one line in the section "Frame rate in internal sync mode".

PRELIMINARY
Aegis Electronic Group
www.aegiselect.com

4.7.4 Fixed Trigger Shutter Mode + CLK Sync Trigger (ClockSync)

(TriggerMode=On , SensorSyncMode=ClockSync , TriggerActivation= RisingEdge)

□ This mode starts the exposure with an external trigger input and performs the exposure at the time set by the ExposureTime command (Section 4.8).

□ The trigger is synchronized to the CLK in the camera to initiate the exposure with low latency. However, during image reading, the following

You cannot enter triggers.

□ The frame rate (= trigger input period) is set to "3.5.2.Frame rate in external trigger mode or less than the fastest frame rate listed in the section

Please make it to.

□ There are restrictions on trigger input, so please refer to "4.6.7. Please refer to "When to prohibit external trigger input".

□ The timing chart and timing parameters in this operating mode are shown below.

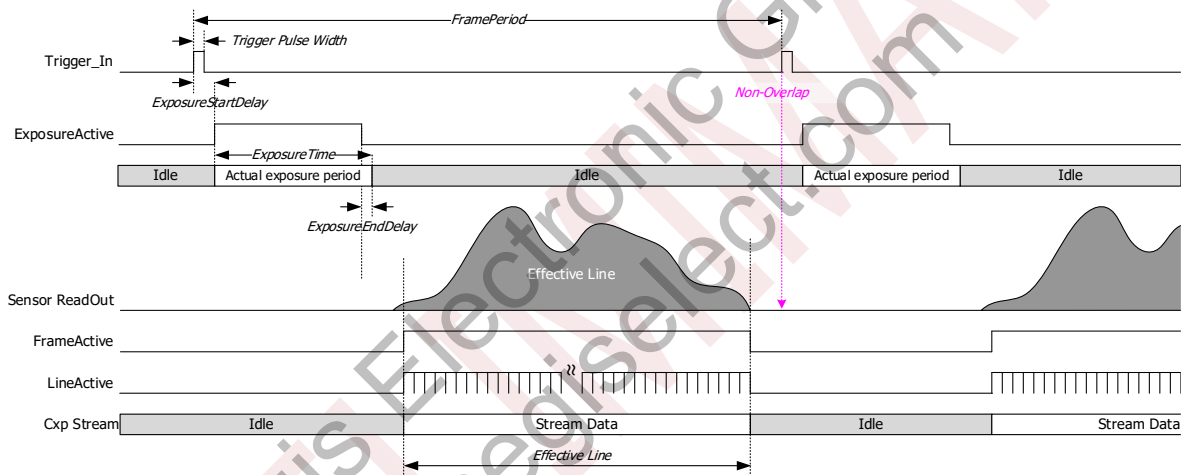

Vertical Sync Timing Chart (Fixed Trigger Shutter Mode + CLK Sync Trigger (ClockSync))

Timing Parameter	Value	Description
Trigger Pulse Width	1	Trigger Input Pulse Width (Minimum) [μs]
Exposure Time Delay	0.13	Delay time from trigger input rise to ExposureActive rise [μs]
Actual Exposure Delay	14.802	Delay time from ExposureActive descent to completion of exposure inside the sensor [μs]
Dataout Delay	74+FPGA	Time from ExposureActive Descent to FrameActive Rise [H]

*The time of 1 hour is "3.5.1. See the time on one line in the section "Frame rate in internal sync mode".

*ExposureActive is output only for the time of the Exposure Time setting minus the Actual Exposure Delay.

4.7.5 Pulse Width Trigger Shutter Mode + H-Sync Trigger (LineSync)

(TriggerMode=On , SensorSyncMode=LineSync , TriggerActivation=LevelHigh)

□ This mode starts the exposure with an external trigger input and controls the exposure time with the trigger pulse width.

□ The trigger is captured synchronously to H in the camera. Because the following trigger can be entered during image reading (=Overlap)

It can operate at high speeds. However, please note that H-synchronous acquisition will cause 1 hour of jitter in the exposure timing.

*Jitter in 1H may occur both at the beginning and end of exposure. Please note that exposure time fluctuations may occur.

□ It is also possible to perform long exposures by extending the pulse width of the trigger. However, during long exposures, dark noise, shading,

The noise may be noticeable.

□ The frame rate (= trigger input period) is set to "3.5.2.Frame rate in external trigger mode or less than the fastest frame rate listed in the section

Please make it to.

□ There are restrictions on trigger input, so please refer to "4.6.7. Please refer to "When to prohibit external trigger input".

□ The timing chart and timing parameters in this operating mode are shown below.

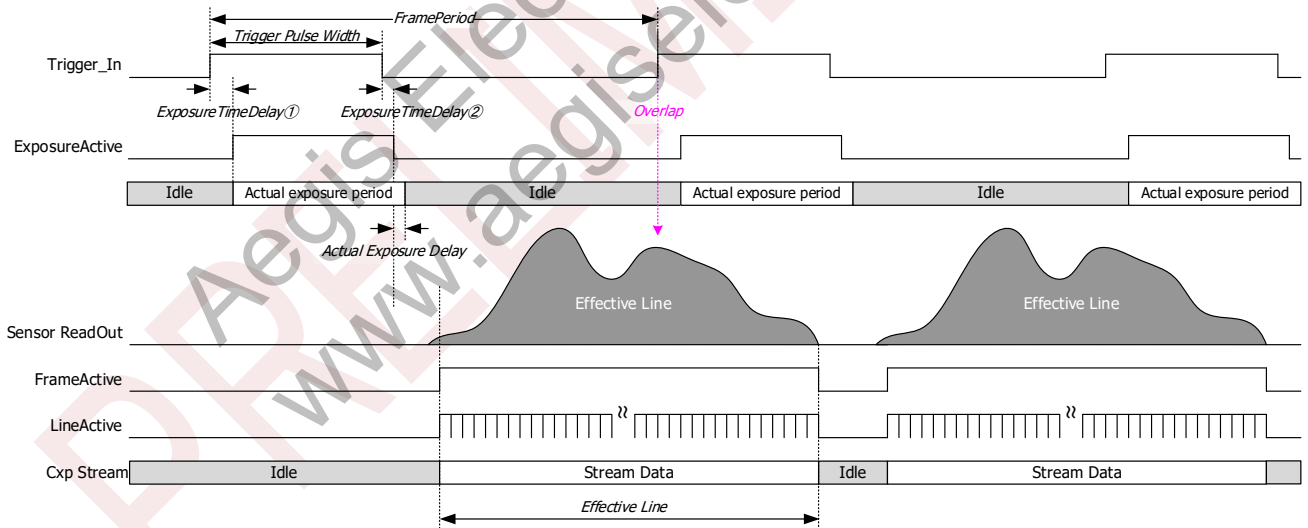

Vertical Sync Timing Chart (Pulse Width Trigger Shutter Mode + H Sync Trigger (LineSync))

Timing Parameter	Value	Description
Trigger Pulse Width(min) (max)	1	Trigger Input Pulse Width (Min) [H]
	200	Trigger Input Pulse Width (Max) [ms]
Exposure Time Delay ①	2 ~ 4	Delay Time from Trigger Input Elevation to ExposureActive Elevation [H]
Exposure Time Delay ②	2 ~ 4	Delay time from trigger input downhill to ExposureActive upright downhill [H]

Actual Exposure Delay	14.802	Delay time from ExposureActive descent to completion of exposure inside the sensor [μ s]
-----------------------	--------	-----------------------------------------------------------------------------------------------

*The time of 1 hour is "3.5.1. See the time on one line in the section "Frame rate in internal sync mode".

PRELIMINARY
Aegis Electronic Group
www.aegiselect.com

4.7.6 Pulse Width Trigger Shutter Mode + CLK Sync Trigger (ClockSync)
 (TriggerMode=On , SensorSyncMode=ClockSync , TriggerActivation=LevelHigh)

□ This mode starts the exposure with an external trigger input and controls the exposure time with the trigger pulse width.

□ Triggers are synchronized to the CLK in the camera, allowing exposures to start and end with low latency. However, during image readout,

You cannot enter the following triggers:

□ The frame rate (= trigger input period) is set to "3.5.2.Frame rate in external trigger mode or less than the fastest frame rate listed in the section

Please make it to.

□ There are restrictions on trigger input, so please refer to "4.6.7. Please refer to "When to prohibit external trigger input".

□ The timing chart and timing parameters in this operating mode are shown below.

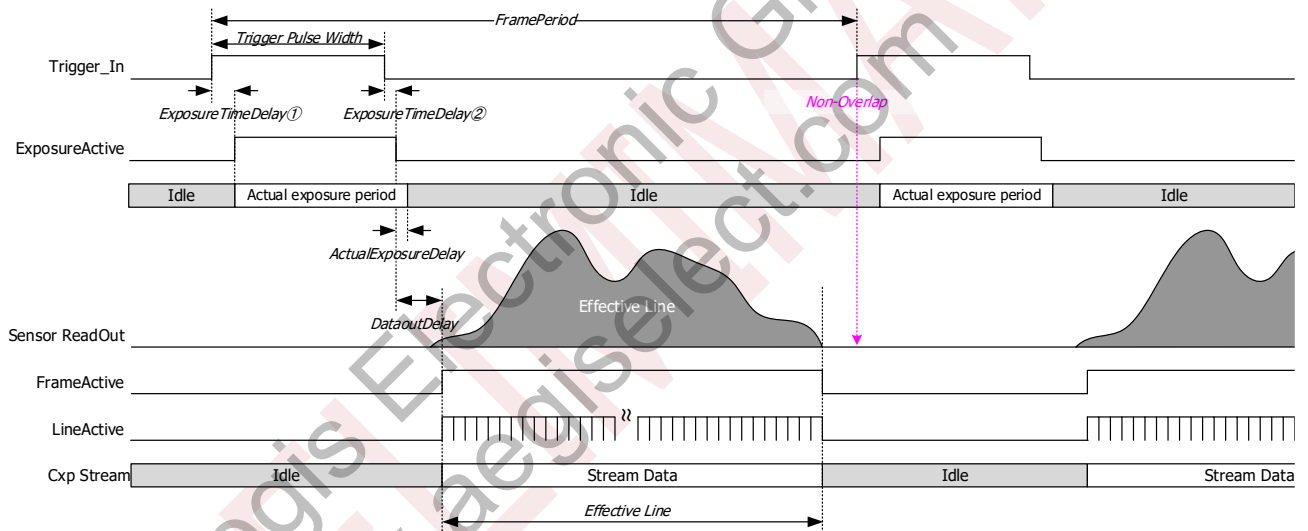

Vertical Sync Timing Chart (Pulse Width Trigger Shutter Mode + CLK Sync Trigger (ClockSync))

Timing Parameter	Value	Description
Trigger Pulse Width(min)	16	Trigger Input Pulse Width (Minimum) [μs]
	(max) 200	Trigger Input Pulse Width (Max) [ms]
Exposure Time Delay ①	0.13	Delay time from trigger input rise to ExposureActive rise [μs]
Exposure Time Delay ②	0.13	Delay time from trigger input upward to ExposureActive upright descent [μs]
Actual Exposure Delay	14.802	Delay time from ExposureActive descent to completion of exposure inside the sensor [μs]
Dataout Delay	Measure	Time from ExposureActive Descent to FrameActive Rise [H]

*The time of 1 hour is "3.5.1. See the time on one line in the section "Frame rate in internal sync mode".

4.7.7 External trigger input prohibition timing

The input timing of external triggers has the following restrictions: Please note that failure to meet these constraints will result in an error.

(1) When SensorSyncMode=ClockSync, the following trigger cannot be entered until the image readout is complete.

(The Trigger Inhibit Period below is prohibited from entering triggers) Please enter the following trigger after the readin

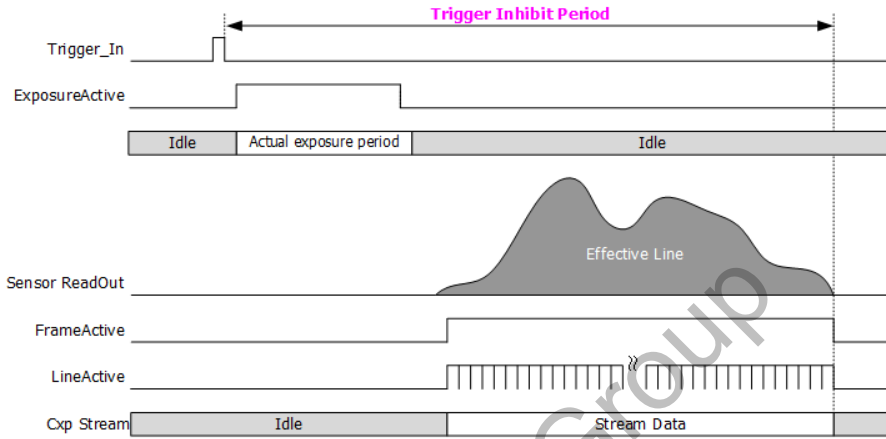

(2) When SensorSyncMode=LineSync, the following trigger can be entered during image readout, but the exposure cannot be terminated before the readout is complete. After the reading is complete, finish the exposure of the next frame and start the readout.

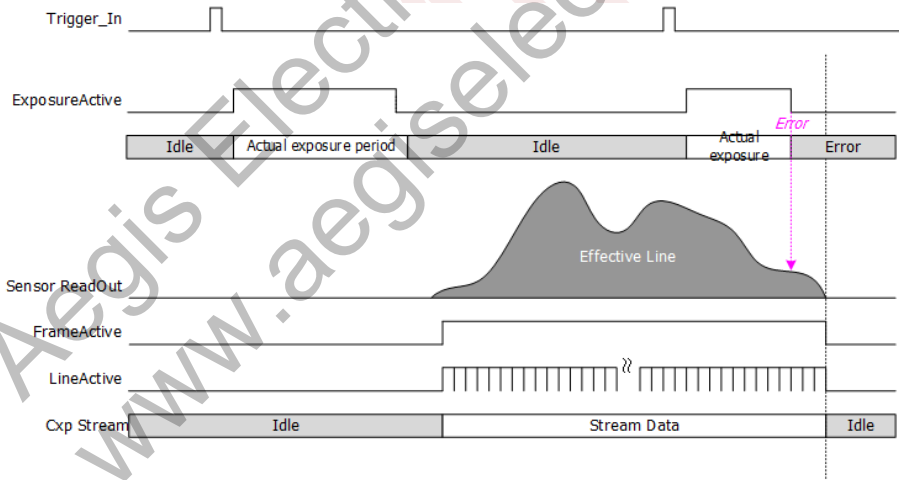

(3) When SensorSyncMode=LineSync and TriggerActivation= RisingEdge/FallingEdge, the following triggers cannot be entered during the exposure period:

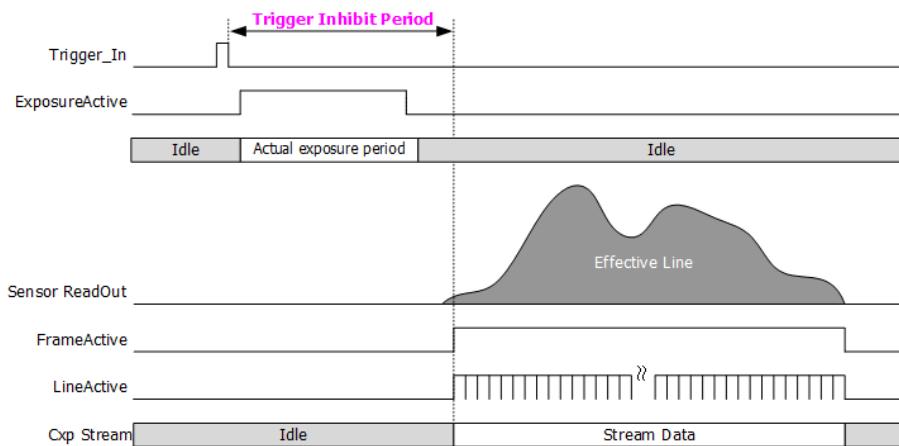

If an external trigger is entered during the ban period, the LED on the back of the camera will be in an error glowing state, and the status can be checked with the following command.

Acquisition Control	
IllegalTriggerFlag	0 or 1 (ReadOnly)

- IllegalTriggerFlag: If there is a trigger input in the prohibition timing, It will be "1".

Device Control	
ErrorFlagReset	(Execute)

- ErrorFlagReset: Reset IllegalTriggerFlag to "0".

4.8. Exposure Time

Acquisition Control	
ExposureMode	Timed TriggerWidth
ExposureTime (us)	LineSync 時: ExposureTime.Min~ExposureTime.Max ClockSync 時: 16μs~200ms

- ExposureMode: You can check whether the current mode is Timed or TriggerWidth.
- ExposureTime: Set the exposure time in us. Effective when ExposureMode is Timed.
 - When H synchronization is triggered, the value (us) rounded to the input value in 1H increments is set.

For details, see 4.7.1.

- When CLK synchronization is triggered, it is set in increments of about 1 us.

- ExposureTime.Min :AndxposureTimeThe minimum exposure time that can be set is displayed in US units.
- ExposureTime.Max :AndxposureTimeThe maximum exposure time that can be set is displayed in US units.

CXP Rate	Pixel Format	ExposureTime.Min[us]	ExposureTime.Max[us]
CXP6	Mono8	24	9330
	Mono10	26	12153
	Mono12	29	14412
CXP12	Mono8	22	7439
	Mono10	23	8117
	Mono12	28	13819

4.8.1 Manual shutter calculation formula when triggering H Sync (LineSync)

ExposureTime is rounded to a number that applies to the following formula.

$$\text{Exposure Time} = \text{1 line time} \times \text{number of exposure lines} + 14.802\mu\text{s}$$

The minimum number of exposure lines is 2 lines.

- The maximum number of exposure lines is clipped at 2056 or the total number of lines at partial time.

4.8.2 Manual shutter setting in CLK Sync mode

- Minimum setting: 16us (approximate)
- Maximum setting value: 200ms(Approximate)
- *Unlike H sync mode, clips are not performed with the number of effective lines.
- Setting unit: 1 μs (approximate)

※74. There is a slight error because it is generated from a clock of 25MHz.

4.9. gain

AnalogControl	
Gain	1.00 ~ 128.00
HighSensitivityMode	LCG/HCG

- Gain: 0 from 1.00x to 128.00x.01 You can set it arbitrarily in step.
It is possible to set it to 16.00x or more, but it is inevitable that the image quality will deteriorate at high gain (around 16x) and the fixed pattern noise will become noticeable. Please use it after evaluation.
*The 8-bit mode is internally granted 4times offset gain, and the image quality deteriorates significantly when it is 4times or more.

- ◆ HighSensitivityMode : High sensitivity mode will be set.
 - LCG Normal mode
 - HCG High sensitivity mode (About 8.6dB sensitivity is improved, but more prone to saturation)

4.10. Sensor Black Level Adjustment

AnalogControl	
BlackOffset	-64 ~ 63

- ◆ BlackOffset: It is a function that adjusts the black level of the sensor.
 - This feature does not specify the absolute value of the black level, but rather adjusts relative to it.
 - This setting value is a 12-bit converted value, 1/4 of the set value at 10-bit, and 1/4 of the set value at 8-bit
 - It will be 1/16.

4.11. Partial Scan (SingleROI)

- This mode allows you to speed up the frame rate by cutting out and reducing the readout area.

ImageFormatControl	
RegionSelector	Region0 (ReadOnly)
RegionMode	Off/On
RegionDestination	Stream0 (ReadOnly)
Width	64~2592
Height	64~2056
OffsetX	0~(2592-Width)
Offsets	0~(2056-Height)

- ※ Make sure you don't change the values while retrieving the image.

- SingleROI

- The RegionSelector is fixed to Region0.
- By turning on RegionMode, Width, Height, OffsetX, and OffsetY can be set.
- RegionDestination is fixed to Stream0.
- You can specify the size of the ROI in X direction in 8 pixels in Width.
- You can specify the size of the ROI in the Y direction in 4-line increments in Height.
- OffsetX allows you to specify the Offset from the left in the X direction of the ROI in 8-pixel increments.
- OffsetY allows you to specify the Offset from above the Y direction of the ROI in 4-line increments.
- OffsetX and OffsetY must be configured to meet the following conditions:
OffsetX+Width<=2592, OffsetY+Height<=2056

- Cannot be used in conjunction with Binning.
- It can be used in conjunction with shading correction and defect correction.

4.12. Partial Scan (MultiROI)

- This mode can speed up the frame rate by cutting out and reducing multiple vertical areas, but it cannot be used in conjunction with Shading correction or defect correction.

ImageFormatControl	
SensorROIEnable	False/True
SensorROISelector	ROI0~ROI7
SensorROIMode[SensorROISelector]	Off/On
SensorROIWidth[SensorROISelector]	64~2592
SensorROIHeight[SensorROISelector]	64~2056 ※
SensorROIOffsetX[SensorROISelector]	0~(2592-SensorROIWidth)
SensorROIOffsetY[SensorROISelector]	0~(2056-Height) ※

※ For SensorROIHeight and SensorROIOffsetY, make sure that the area of all active SensorROIs does not exceed the full-size area. Also, make sure that the SensorROI areas set in each SensorROIHeight and SensorROIOffsetY do not overlap.

※ Make sure you don't change the values while retrieving the image.

□ MultiROI

- Setting SensorROIEnable to True will enable the MultiROI setting.
- You can modify the SensorROIMode, SensorROIWidth, SensorROIHeight, SensorROIOffsetX, and SensorROIOffsetY settings for the ROI configured in SensorROISelector.
- SensorROIMode toggles whether to enable or disable the ROI you set in SensorROISelector. SensorROIEnable=False. If SensorROIMode=On, use SensorROIWidth/SensorROIHeight/SensorROIOffsetX/SensorROIOffsetY is not configurable. If you want to change the settings, set SensorROIMode=Off
- SensorROIWidth sets the horizontal size of MultiROI. The same settings for each ROI. You can specify it in 8pixel increments.
- SensorROIHeight sets the vertical size of the ROI set in SensorROISelector. You can set individual vertical sizes for each ROI. It can be specified in 4-line increments.
- SensorROIOffsetX sets the horizontal offset for MultiROI. The same settings for each ROI. You can specify it in 8pixel increments.
- SensorROIOffsetY sets the vertical offset of the ROI set in the SensorROISelector. You can set individual vertical offsets for each ROI. It can be specified in 4-line increments.

Example:

```

SensorROIEnable      True
SensorROIMode[ROI0]  On
SensorROIWidth[ROI0] 640 *This is the same width for all ROIs.
SensorROIHeight[ROI0] 64
SensorROIOffsetX[ROI0] 128 *OffsetX is common for all ROIs.
SensorROIOffsetY[ROI0] 12

SensorROIMode[ROI1]  On
SensorROIWidth[ROI1] 640 *This is the same width for all ROIs.
SensorROIHeight[ROI1] 128
SensorROIOffsetX[ROI1] 128 *OffsetX is common for all ROIs.
SensorROIOffsetY[ROI1] 256

SensorROIMode[ROI2]  On
SensorROIWidth[ROI2] 640 *This is the same width for all ROIs.
SensorROIHeight[ROI2] 64
SensorROIOffsetX[ROI2] 128 *OffsetX is common for all ROIs.
SensorROIOffsetY[ROI2] 512

```

- SensorROI Mode[ROI3] On
- SensorROI Width[ROI3] 640 *This is the same width for all ROIs.
- SensorROI Height[ROI3] 1000
- SensorROI OffsetX[ROI3] 128 *OffsetX is common for all ROIs.
- SensorROI OffsetY[ROI3] 700

- SensorROI Mode[ROI4] Off
- SensorROI Mode[ROI5] Off
- SensorROI Mode[ROI6] Off
- SensorROI Mode[ROI7] Off

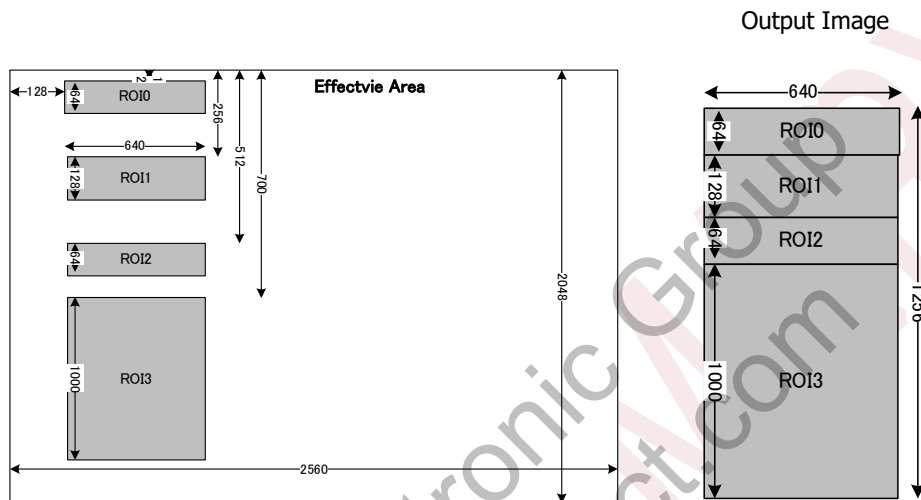

4.13. 2x2 binning mode

□ You can set the binning mode (simple addition mode, average mode).

ImageFormatControl	
BinningHorizontal	1~2
BinningHorizontalMode	Sum/Average
BinningVertical	1~2
BinningVerticalMode	Sum/Average

• BinningHorizontal: Set horizontal binning to be enabled or disabled.

- 1: Disable binning
- 2: Binning enabled

• BinningHorizontalMode: Horizontal binning mode.

Sum: Additive mode (outputs 4 pixels of height and width as 1 pixel). The sensitivity is about 4 times higher.

Average: Average mode (outputs 4 pixels of height and width as 1 pixel). The sensitivity will be the same as usual.

• BinningVertical: Set the vertical binning to be enabled or disabled.

- 1: Disable binning
- 2: Binning enabled

• BinningVerticalMode: Vertical binning mode.

Sum: Additive mode (outputs 4 pixels of height and width as 1 pixel). The sensitivity is about 4 times higher.

Average: Average mode (outputs 4 pixels of height and width as 1 pixel). The sensitivity will be the same as usual.

[Note]

- The settings of BinningHorizontal and BinningVertical cannot be changed while grabbing (while acquiring images).
- The settings of BinningHorizontal and BinningVertical are linked.
If you change one of them, the other will also change to the same settings.
- You cannot enable 2x2 binning for anything other than full-size.

4.14. Pixel defect correction

- This is a function that registers data and corrects the coordinates of "defective pixels" contained in the sensor.
- Defect coordinate data is managed in two main types.

Factory data

It retains white and black spot defect data detected at the time of product shipment.
You can't erase this data.

- User registration data

This is data that users can register, such as when defects increase after shipment.
DefectPixelDefault can delete user-registered defect data.

- Defect pixel correction information is kept separately during normal and up-down flips.
(The position and number of defective pixels are different between normal and up-and-down flipping.)
- The number of points that can be registered as a user is 2048. (However, each CH is limited to 256 points.)

[CH (Channel)] The image is processed by 8CH interleaved inside the camera.

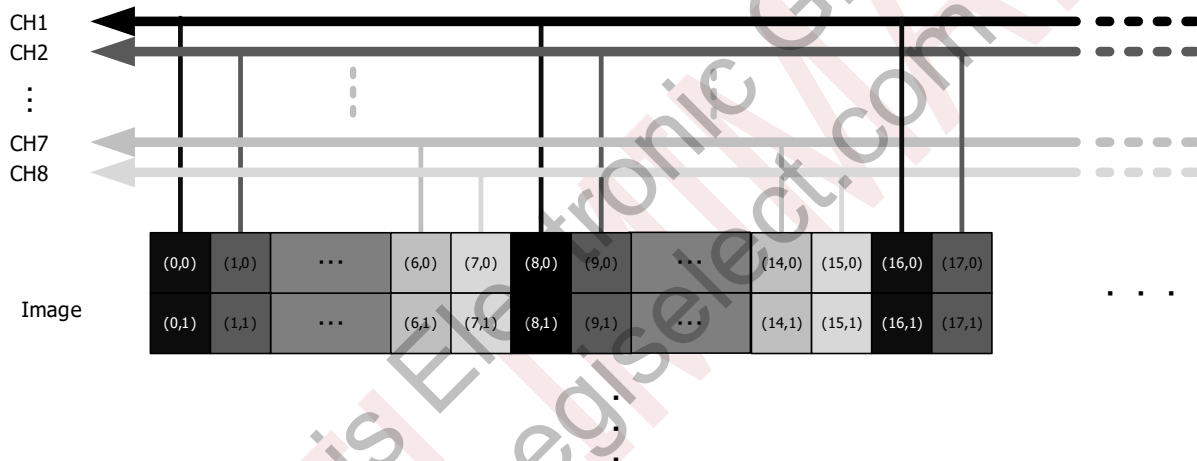

- On/Off Control of Fault Compensation

AnalogControl	
DefectPixelCorrection	On/Off

- DefectPixelCorrection: Select Enable or Disable Defect Pixel Correction.
 - *Please note that factory data and user registration data are not distinguished, and both are turned on/off.
 - *When enabling MultiROI, set DefectPixelCorrection to Off.
 - *If the noise filter is enabled, please disable it and then set it to Off.

- User registration (coordinate designation)

This function allows you to register and delete any pixel as defective pixels by specifying X and Y coordinates.



*For black and white models
Refer to the pixel values of the top, bottom, left, and right as shown on the left to calculate the X pixel value.
Even if you register a new X while the defective pixels of X1, X2, X3, and X4 are already registered, X is not compensated.

AnalogControl		
DefectPixelAdd	(Execute)	
DefectPixelAddOffsetY	0~2591	[Not eligible for saving settings]
DefectPixelAddOffsetX	0~2055	[Not eligible for saving settings]
DefectPixelDelete	(Execute)	
DefectDetectionStatus	(ReadOnly)	

- DefectPixelAddOffsetY: Specify the Y coordinate to be registered(Coordinates before binning when binning)
- DefectPixelAddOffsetX: Specify the X coordinate to be registered(Coordinates before binning when binning)
- DefectPixelAdd: The specified coordinates are registered as trapped pixel correction points.
- DefectPixelDelete: Deletes data that has been registered as a defective pixel correction point with the specified coordinates.

specified coordinates.

*The DefectPixelDelete command allows you to delete only the data that has been registered as a user (coordinates specified). Factory data cannot be deleted. (If you specify the same coordinates as the factory defect data, it will be ignored.)

*When registered with the DefectPixelAdd command, it is not stored in non-volatile memory. If you want to save it in non-volatile memory, run the UserSetSave command.

- DefectDetectionStatus – Indicates the result of the user-registered defect detection action.

0	User registration defect correction data is not available
Numeric (1024 or less)	Number of user registration defects
Error	
0x000e0001(917505)	The total number of user registration defect correction data exceeds the maximum number of registrations (512 points).

- Delete all user registration information

Information registered by users through coordinate designation and defect detection can be deleted in bulk with the following command.

AnalogControl	
DefectPixelDefault	(Execute)

- DefectPixelDefault :Delete all user registration (coordinate designation and defect correction) data.

- Defect Registration Data Display

You can view the information of the factory data and user registration data that has been registered.

AnalogControl		
RegisteredDefectSelector	UserState/InitialState	[Not eligible for saving settings]
RegisteredDefectNumber	(ReadOnly)	
DefectPixelNumber	1~512	[Not eligible for saving settings]
DefectPixelOffsetY	(ReadOnly)	
DefectPixelOffsetX	(ReadOnly)	
DefectPixelType	(ReadOnly)	

- RegisteredDefectSelector — Select the type of data to display:

©2025 CIS Corporation. All rights reserved.

UserState: User registration data
 InitialState: Factory Data

- RegisteredDefectNumber — Displays the number of defects being corrected.
- DefectPixelNumber : Specifies the number of the defect table that is registered in the selected data.
- DefectPixelOffsetY : DefectPixelNumber displays the Y coordinates of the defect specified in it.

If the table number has no defect data, 65535 is displayed.

When binning, the coordinates before binning are displayed.

- DefectPixelOffsetX : D displays the X coordinates of the defect specified by the effectPixelNumber.

If the table number has no defect data, 65535 is displayed.

When binning, the coordinates before binning are displayed.

- DefectPixelType : D Indicates the defect type specified by effectPixelNumber.
 - 1: Factory white defect
 - 2: Factory black defects
 - 7: User Addition Registration Defect
 - 65535: Tables without defective data

AnalogControl	
ChannelNumber	1~8 [Not eligible for saving settings]
DefectPixelChannelCount	(ReadOnly)

- ChannelNumber: Specifies the channel number for defect handling.
- DefectPixelChannelCount — Displays the number of defects for the channel number specified in ChannelNumber.

The number of types selected in the RegisteredDefectSelector.

※ Even when used with Binning, it is displayed in a full-size coordinate system.

4.15. Noise Filter

- This is a function that compensates for pixel defects in real time. Since this feature is used in conjunction with pixel defect correction, the noise filter cannot be set to True when DefectPixelCorrection is off.

[Note]

- This feature is not supported in the case of MultiROI.

PixelCorrectionControl	
ImpulseNoiseFilter	True/False
ImpulseNoiseFilterThreshold	0~4095

- ◆ ImpulseNoiseFilter

If set to False, the noise filter function will not work.

If true, the correction is set for the point where the difference between the surrounding pixels and the featured pixels is greater than the value of ImpulseNoiseFilterThreshold.

Multiply.

*Adverse effects due to overcorrection may occur. Be sure to check the image before using it.

*If the threshold is set to 4095, the defect will no longer be detected.

*Please check the image and adjust the threshold according to the usage situation.

4.16. Test Pattern Display

Test patterns can be output from the camera that can be used to check the operation of the system.

ImageFormatControl	
TestPattern	Off GreyScale GrayHorizontalRamp

*Cursor display is exclusive control.

4.17. Cursor display

You can display the cursor on the screen. *Test pattern display is exclusive control.

ImageFormatControl	
CursorPattern	On/Off
CursorOffsetX	0 ~ 2591
CursorOffsetY	0 ~ 1055
CursorColor	White/Black

- CursorPattern: Specifies whether or not the cursor is displayed.
- CursorOffsetX: Specifies the X coordinate of the vertical cursor.
- CursorOffsetY: Specifies the Y coordinate of the horizontal cursor.
- CursorColor: Specify the color of the cursor. (White/Black)

*Test pattern display is exclusive control.

[Note]

- When displaying partial (ROI), the cursor coordinates are the origin of (0,0) in the upper left corner of the active area.
- When the displayed image is zoomed out, the cursor may not be displayed.

4.18. LED Operating Modes

Change the LED behavior on the rear of the camera. For details on the lighting pattern, see "3.3.3. LED Indicators.

DeviceControl	
DeviceIndicatorMode	Active ErrorStatus Inactive

- DeviceIndicatorMode: Choose from three types of LED behavior.
 - Active: Displays the CoaXPress communication status.
 - ErrorStatus: Normally turned off and turned on only when an error occurred.
 - Inactive: Lights are always turned off.

4.19. Camera Timing I/O

You can view/select the functions of the 3,5 pins of the 6-pin circular connector.

Digital IO Control	
LineSelector	Line0 Line1
LineMode[LineSelector]	Input Output
LineSource[LineSelector]	Off FrameTrigger ExposureActive

	FrameActive LineActive TriggerPacketActive
--	--------------------------------------------------

- ◇ LineSelector: Select the Line you want to set up/display.
 Line0: No. 6 Pin Circular Connector3 Pin
 Line1: No. 6 Pin Circular Connector5 Pin
- ◇ LineMode: Displays the input/output direction of the selected Line.
- ◇ LineSource: Select the signal for the selected Line from the following:
 Off : 0 fixed.
 FrameTrigger (Input) : Receives a start trigger.
 ExposureActive (Output) : Hi-active output of the exposure period of the image sensor.
 FrameActive (Output) : Outputs the lifetime of the frame with Hi-Active.
 LineActive (Output) : Prints the lifetime of the line in Hi-Active.
 TriggerPacketActive(Output) : Decode and output the uplink trigger packet signal.
 * If LineSource does not match LineMode (in parentheses above), it will be changed to Off.

Digital IO Control	
LineSelector	Line0 Line1
LineMode [LineSelector]	Input Output
LineSource [LineSelector]	Off FrameTrigger ExposureActive FrameActive LineActive TriggerPacketActive

- ◇ LineSelector: Select the Line you want to set up/display.
 Line0: No. 6 Pin Circular Connector3 Pin
 Line1: No. 6 Pin Circular Connector5 Pin
- ◇ LineMode: Displays the input/output direction of the selected Line.
- ◇ LineSource: Select the signal for the selected Line from the following:
 Off : 0 fixed.
 FrameTrigger (Input) : Receives a start trigger.
 ExposureActive (Output) : Hi-active output of the exposure period of the image sensor.
 FrameActive (Output) : Outputs the lifetime of the frame with Hi-Active.
 LineActive (Output) : Prints the lifetime of the line in Hi-Active.
 TriggerPacketActive(Output) : Decode and output the uplink trigger packet signal.
 * If the LineSource does not match LineMode (in parentheses above), it will be changed to Off.

4.20. Save User ID

You can register any ID or string with the camera.

DeviceControl	
DeviceUserID	Manual
DeviceUserString	Manual

- DeviceUserID: You can set a string of up to 16 characters (including NUL characters (¥0)) on the camera.
- DeviceUserString: Strings up to 256 characters (NUL characters (including ¥0)) can be set to the camera.

When you run "UserSetSave", it is stored in the non-volatile memory in the camera.

※ This item maintains the set value even if you run "UserSetLoad" in "Default".

4.21. Temperature display

This function is used to monitor and control the temperature of the camera.

DeviceControl	
DeviceTemperatureSelector	Sensor Motherboard FPGA
DeviceTemperature	(ReadOnly)
FanSpeed	Off Low High

- ◆ DeviceTemperatureSelector : Select the temperature measurement point.
 - Sensor : Displays the temperature of the CMOS sensor.
 - Motherboard : Displays the temperature of the FPGA.
- ◆ DeviceTemperature : Displays the temperature in °C equivalent.
*This temperature is not calibrated. It is a reference value.
- ◆ FanSpeed : Select the operation of the built-in fan.
 - Off : Stop it
 - Low : Low speed operation
 - High : High speed operation
- ◆ Please do not block the vents on the left and right sides of the chassis.

4.22. Connection Reset

In the event of a CXP connection problem, you can reset the Device with the following commands.

Transfer Control	
ConnectionReset	1(Execute)

- ◆ ConnectionReset: Reset your device and reconnect it automatically.
 - ※ It will take a few seconds to reconnect, so please make sure it is reconnected before using it.
 - * Some items (DeviceTemperature, IllegalTriggerFlag, etc.) may be temporarily displayed with an error until the reconnection is completed. Please re-retrieve it after reconnecting.

4.23. Gamma correction

Gamma correction can be performed.

AnalogControl	
Gamma	0.10~2.20 coefficient settings

- ◆ Gamma : Gamma correction value is

0.10~2. It can be set up to 20 in 0.01 steps.

[Note] The gamma table is updated at the image output timing, and the gamma table is rewritten when it is in continuous operation.

(Approx. 20ms: Command ACK is approximate) is applied when the image is output after

completion.

If you change the gamma factor while waiting for the trigger, the trigger after the table rewrite is completed
Output gamma update images.

4.24. Image quality selection mode

This is the ability to choose the quality of the output image.

AnalogControl	
ImageQualityMode	StandardMode LowFrameRateMode

- ♦ Image Quality Mode : Image quality selection mode
 - ♦ StandardMode : Standard Mode
 - ♦ LowFrameRateMode : StandardMode ComparedS/N Improvement Modes
However, the frame rate and sensitivity are reduced.
The frame rate will be the same value as at 10-bit.
PixelFormat can only be set when Mono8 is configured. If you select Mono 10/12, it will update to Standard Mode.

4.25. Shading Correction

- This function compensates for the drop in ambient light caused by lenses and other factors.

AnalogControl	
ShadingCorrectionDataSelector	Off/Table1/Table2/Table3/Table4
DetectShading	(Execute)

- ♦ ShadingCorrectionDataSelector :
Shading Off or select the Shading Correction Table to use.
If you select Table1- Table4, the correction function will be turned on for each correction value.
*MultiROI and shading correction cannot be used together. It can be used in conjunction with SingleROI.
- ♦ DetectShading :
Table1- You can retrieve correction data to the specified Table by performing DetectShading while selecting Table4.
When detecting shading, make sure to set MultiROI to OFF and full-size.
Image the entire screen of a uniform level of subject, such as a pattern box.
To save the obtained correction data, run UserSetSave.

Before Shading Correction After Shading Correction

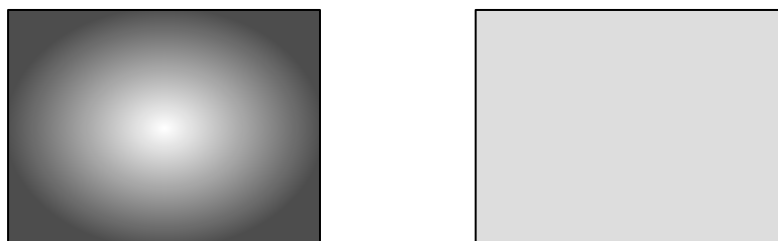

[Note]

- Obtain correction data only while the camera is in operation.
(Shading correction data cannot be obtained when the camera is not output.)

- When UserSetSave is executed, the correction data of Table1~Table4 is stored in non-volatile memory at the same time.
- Correction data is retained even if Default is run on UserSetLoad.
- When performing a vertical reversal, please obtain the shading correction data again.
- ShadingCorrectionCannotbe executed if DataSelector is Off.

PRELIMINARY
Aegis Electronic Group
www.aegiselect.com

5. Factory Settings

function	data	explanation
DeviceControl		
DeviceUserID		No user string (16 characters) setting
DeviceUserString		No user string (256 characters) setting
DeviceIndicatorMode	Active	LED operating mode CoaXPress communication status display
ImageFormatControl		
PixelFormat	Mono8	monochrome 8bit
RegionSelector	Region0	Partial Area (ROI) Region0 Enabled State
RegionMode	On	Partial Area (ROI) Operation On
Width	2592	Partial Area (ROI) Horizontal 2592pixel (Full-Size)
Height	2056	Partial Area (ROI) Vertical 2056line (Full Size)
OffsetX	0	Partial Area (ROI) Horizontal Start Position 0
Offsets	0	Partial Area (ROI) Vertical Start Position0
SensorROIEnable	False	Multi ROI Off
SensorROISelector	ROI0	
SensorROIMode	Off	
SensorROIWidth	2592	
SensorROIHeight	2056	
SensorOffsetX	0	
SensorOffsetY	0	
BinningHorizontal	1	2x2 binning mode disabled
BinningHorizontalMode	Average	Binning Average Mode Settings
BinningVertical	1	2x2 binning mode disabled
BinningVerticalMode	Average	Binning Average Mode Settings
ReverseX	FALSE	Left and right flip OFF
ReverseY	FALSE	Flip up and down OFF
CursorPattern	Off	Cursor display off
CursorOffsetX	1296	X coordinate of vertical cursor = 1296
CursorOffsetY	1024	Y vertical of horizontal cursor = 1024
CursorColor	White	Cursor Color = White
TestPattern	Off	Test Pattern Display Off
AcquisitionControl		
TriggerSelector	AcquisitionStart	Internal Sync Mode (Freerun)
TriggerMode	Off	Internal Sync Mode (Freerun)
SensorSyncMode	LineSync	H Sync Mode
TriggerSource	LinkTrigger0	CXP UpLink Triggers
TriggerActivation	RisingEdge	Rising Edge
ExposureTime	9330.0	Exposure time 9330 μ s
AcquisitionFrameRate	105.1401	Frame rate@CXP6 Mono8
AnalogControl		
Gain	1.00	gain1.00x
Gamma	1.00	Gamma correction value 1.00
BlackOffset	0.0	Black Level Default
ShadingCorrectionDataSelector	Off	Shading Correction Off
ImageQualityMode	StandardMode	Image quality selection mode (standard mode)

ImpulseNoiseFilter	False	Noise Filter OFF
ImpulseNoiseFilterThreshold	4095	Noise Filter Threshold
DefectPixelCorrection	On	Defect pixel correction On
DefectPixelAddOffsetX	0	Specify the X coordinate of the correction pixel = 0
DefectPixelAddOffsetY	0	Y coordinate designation of correction pixel = 0
TransportLayerControl		
CxpLinkConfiguration	CXP6_X1	CxpLinkConfiguration, CXP-6(6.25Gbps), 1Link
DigitalIOControl		
LineSelector	Line0	Line0
LineMode	Input	Trigger Input
LineSource	Off	0 Fixed

※ ConnectionConfig , PixelFormat , ImageQualityMode are not work in UserSetLoad

6. Dimensions

6.1. External Dimensions

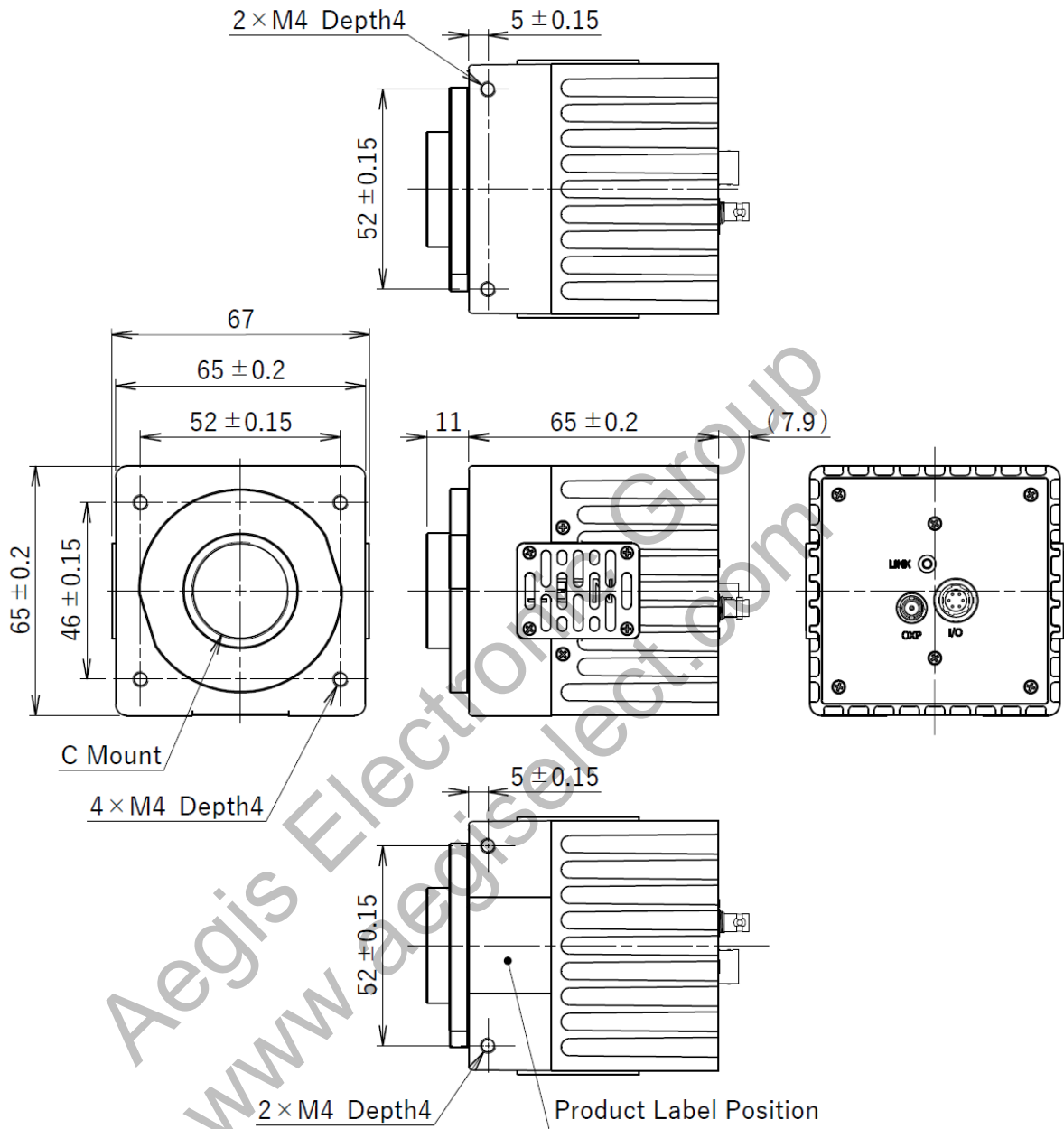

Note1) C mount screws comply with ANSI/ASME B1.1,1-32UN(2B)

935-0212-00
(Unit : mm)

6.2. Optical Axis Accuracy

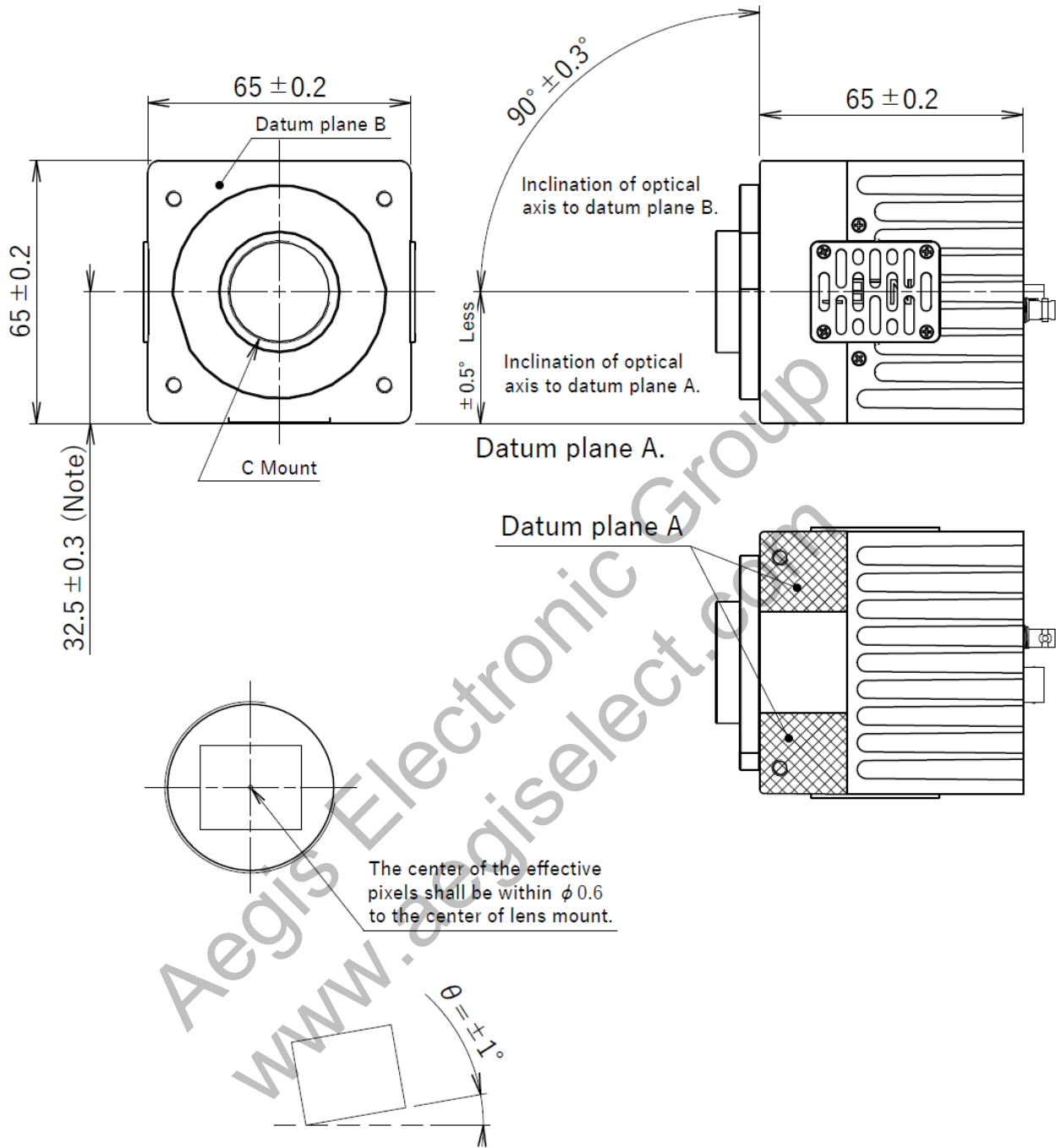

Inclination of effective pixels θ to datum plane A is $\theta \cong \pm 1^\circ$.

Note:Dimensions from datum plane A to the center of the lens mount.

937-0047-00
(Unit : mm)

7. Case for Indemnity (Limited Warranty)

7.1. Product Warranty

The warranty period of this product is 3 years from the date of shipment from our company.

During this period, if a malfunction occurs due to our design or manufacturing, we will repair it free of charge in accordance with the product service in clause 7.3.

However, damage or breakdown caused by the customer's negligence in handling, or natural disasters such as fire, earthquake, lightning strike, storm and flood damage, or force majeure is not covered by the warranty.

Repairs after the warranty period has expired will be repaired for a fee if repaired is possible.

7.2. CMOS Pixel Defect

At the time of shipment, noticeable pixel defects are corrected and shipped, but after the product is shipped, new pixel defects may occur due to the unique characteristics of the imaging sensor, and some defect levels may increase over time. These are excluded from the product warranty.

For details of pixel defect correction, please contact our sales department.

7.3. Product Support

If the product does not work properly due to any factor after purchasing the product, please contact the dealer where you purchased it for investigation, analysis, and repair.