

# CIS

**CoaXPress I/F  
2M pixels CMOS (RAW) Camera**

# VCC-2CXP6R

**Product Specifications  
& Operational Manual**

**CIS Corporation**

## Table of Contents

1.	Handling Precautions.....	1
1.1.	Camera Handling Precautions.....	1
1.2.	Restrictions on Applications.....	1
1.3.	Disclaimers (Exception Clause).....	1
2.	Product Outline.....	2
2.1.	Features.....	2
3.	Specifications.....	3
3.1.	General Specifications.....	3
3.2.	Input and Output Specifications.....	5
3.2.1	6pins Circular Connector No.5 pin: TRIGGER_IN Circuit.....	5
3.2.2	6pins Circular Connector No.3 pin SIGNAL_OUT Circuit.....	5
3.3.	External Connector Pin Assignment.....	6
3.3.1	6pins Circular Connector HR10-10R-12PA(73) (HIROSE) or Equivalent.....	6
3.3.2	75Ω BNC Connector.....	6
3.3.3	LED Indicator.....	7
3.4.	Spectral Response.....	7
4.	Output Timing.....	8
4.1.	Horizontal Sync Timing.....	8
4.2.	Vertical Sync Timing.....	9
5.	Camera Functions.....	10
5.1.	Camera Interface.....	10
5.2.	How to Save and Initialize Settings.....	10
5.3.	Link Speed and Link Count.....	10
5.4.	Pixel Format (RAW).....	11
5.5.	Trigger Mode.....	11
5.5.1	Internal Sync Mode (Free Run Mode).....	11
5.5.2	External Trigger Sync Mode.....	11
5.6.	Trigger Sync Mode and Delay Time to Start Exposure.....	13
5.7.	Restrictions on Trigger Pulse Input Timing.....	14
5.8.	Fixed Trigger Shutter Mode (LineSync) H Sync Trigger.....	15
5.9.	FAST Fixed Trigger Shutter Mode (ClockSync) CLK Sync Trigger.....	16
5.10.	Pulse Width Trigger Shutter Mode (LineSync) H Sync Trigger.....	17
5.11.	FAST Pulse Width Trigger Shutter Mode (ClockSync) CLK Sync Trigger.....	18
5.12.	Exposure Time.....	19
5.13.	Formula to Calculate Manual Shutter Values with H Sync Mode.....	20
5.14.	Manual Shutter Settings with CLK Sync Mode (FAST Trigger Mode).....	20
5.15.	Gain.....	20
5.16.	Gamma Correction.....	20
5.17.	Partial Scan (ROI).....	21
5.18.	White Balance.....	23
5.19.	Black Level Adjustment.....	24
5.20.	Image Quality Selecting Mode.....	24
5.21.	Defective Pixel Correction.....	24
5.22.	Test Pattern Indication.....	28
5.23.	Cursor Indication.....	28
5.24.	LED Operational Mode.....	28
5.25.	Camera Timing Output.....	29

---

- 5.26. User ID ..... 29
- 5.27. Temperature Indication ..... 29
- 6. Factory Settings ..... 30
- 7. Dimensions ..... 31
  - 7.1. Camera Dimensions ..... 31
  - 7.2. Optical Axis Accuracy ..... 32
- 8. Case for Indemnity (Limited Warranty) ..... 33
  - 8.1. Product Warranty ..... 33
  - 8.2. CMOS Defective Pixels ..... 33
  - 8.3. Product Support ..... 33

Aegis Electronic Group  
www.aegiselect.com

## 1. Handling Precautions

### 1.1. Camera Handling Precautions

- Do not use or store camera in dusty or humid places.
- Do not apply excessive force, vibration, or static electricity that could damage camera. Please handle camera with care.
- Do not shoot direct images that are extremely bright (e.g., strong light source, sun, etc.). When extremely strong light source is shot, smear or blooming may occur. Put the lens cap on or protect the lens with seal when camera is not in use.
- Follow the instructions in [Chapter 3.3, "External Connector Pin Assignment"](#) for connecting camera. Improper connection may cause damages not only to the camera but also to the connected devices.
- Confirm mutual ground potential carefully before connecting camera to monitors or computers. Any AC leak from the connected devices may cause damages or destroy the camera.
- Do not apply excessive voltage. (Use only the specified voltage.) Unstable or improper power supply voltage may cause damages or malfunction of the camera.
- Our warranty does not apply to damages or defects caused by irregular and/or abnormal use of the product.

**Our warranty does not apply to damages or defects caused by neglecting the instructions and precautions explained in this manual.**

### 1.2. Restrictions on Applications

- The camera must not be used for any nuclear equipment or aerospace equipment with which mechanical failure or malfunction could result in serious bodily injury or loss of human life.
- The camera must not be used under conditions or environments other than those specified in this manual.

### 1.3. Disclaimers (Exception Clause)

CIS should not be liable for any damages or losses if;

- damages or losses are caused by earthquake, lightning strike, fire, flood, or other acts of God.
- damages or losses are caused by deliberate or accidental misuse by user, or failure to observe information and instructions explained in this manual.
- damages or losses are caused by repair or modification conducted by user or any unauthorized party.

## 2. Product Outline

VCC-2CXP6R is color camera with CoaXPress interface utilizing 1/1.7 type CMOS image sensor. Compact in size, 29mm (H) x 29mm (W) x 55mm (D) with 2M pixels resolution. Complies with CoaXPress Version 1.1.1. Must have function ready for Machine Vision applications such as trigger shutter, ROI, Gain, black level adjustment, defective pixel correction, and PoCXP. Suitable for various FA/Machine vision applications.

### 2.1. Features

- Small footprint: 29mm(H) x 29mm(W) x 55mm(D)
- Global shutter type CMOS sensor
- Complies with CoaXPress CXP-3 and CXP-6
- Exposure setting, Gain setting
- External trigger mode (Fixed trigger shutter mode / Pulse width trigger shutter mode)
- Complies to GenICam
- C mount

Aegis Electronic Group  
www.aegiselect.com

## 3. Specifications

## 3.1. General Specifications

<b>Electrical Specifications</b>			
Image sensor	Sensor type	1/1.7", Global shutter type CMOS sensor	
	Effective pixels	1632(H) × 1248(V)	
	Unit cell size	4.5μm(H) × 4.5μm(V)	
Interface		Complies with CoaXPress Ver. 1.1.1., CXP-6 / CXP-3 x1	
Video output frequency	Pixel clock frequency	74.25MHz	
Video output format		Mono8 / Mono10 / Mono12 , BayerRG8 / BayerRG10 / BayerRG12	
Frame rate	CXP-3 8bit/10bit/12bit x1 lane	119.5fps/97.3fp/82.7fps	
	CXP-6 8bit/10bit/12bit x1 lane	239fps/194.5fps/165.5fps	
Sync system		Internal sync.	
Resolution (The maximum pixel size)		1632(H) × 1248(V)	
Video signals (Gain 0dB)	White clip level	255	with 8bit
	Set up level	0~2	with 8bit
	Dark shading	4 or less for both horizontal and vertical	with 8bit
Sensitivity		F11 2000lx (Shutter speed 1/30s, Gain 0dB, BayerRG 8 ) F5.6 2000lx (Shutter speed 1/30s, Gain 0dB, BayerRG 10,12 )	
Minimum illumination		F1.4 2.0lx (Shutter speed 1/30s, Gain +18dB, BayerRG 8, level=50%) F1.4 7.5lx (Shutter speed 1/30s, Gain +18dB, BayerRG 10, 12, level=50%)	
Gain variable range		x1~x64 (0dB~+36dB) [Warranty coverage]	
Shutter speed		Manual	
Trigger mode		Free run mode (Camera internal trigger) Trigger mode (Host, External terminal) · Fixed trigger shutter · Pulse width trigger shutter	
Partial scan		Vertical 8 areas can be set.	
Power requirements		PoCXP: 18.5~26V	
Power consumption		3.4W(CXP-3), 3.6W (CXP-6), [with free run]	
<b>Mechanical Specifications</b>			
Dimensions		H:29mm W:29mm D:55mm excluding projection	
Weight		Approx. 66g	
Lens mount		C mount	

<b>Environmental Specifications</b>			
Safety/Quality standards			
UL: Complies with UL standard including materials. CE: EMC 2014/30/EU EN61000-6-4:2007+A1:2011 for Emission EN61000-6-2:2005 for Immunity RoHS: 2011/65/EU, 2015/863/EU EN50581(RoHS2)			
Durability	Vibration	Acceleration	: 98m/s <sup>2</sup> (10G)
		Frequency	: 20 ~ 200Hz
		Direction	: X, Y, and Z 3 directions
		Testing time	: 120min each
	Shock	No malfunction with 980m/s <sup>2</sup> (100G) for ±X, ±Y, and ±Z, 6 directions without packaging.	
Operational temperature		0 ~ +45°C	
		Humidity: 20 ~ 80%RH with no condensation.	
Storage temperature		-25 ~ +60°C	
		Humidity 20 ~ 80%RH with no condensation.	

Aegis Electronic Group  
 www.aegiselect.com

3.2. Input and Output Specifications

3.2.1 6pins Circular Connector No.5 pin: TRIGGER\_IN Circuit

- 5.0V, 3.3V CMOS level / TTL level
- Input voltage Low: 0.5Vdc (Max), High: 2.1Vdc (Min)

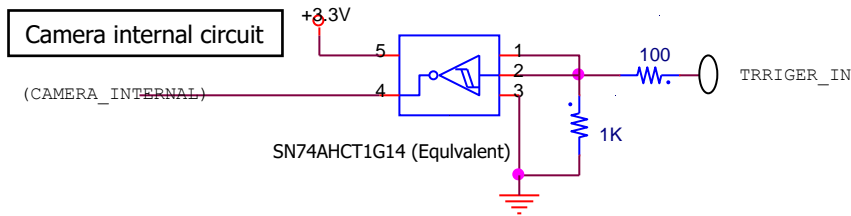

3.2.2 6pins Circular Connector No.3 pin SIGNAL\_OUT Circuit

- 5.0V CMOS logic level output
- Output voltage Low: 0.35Vdc (Max), High: 4.5Vdc (Min)

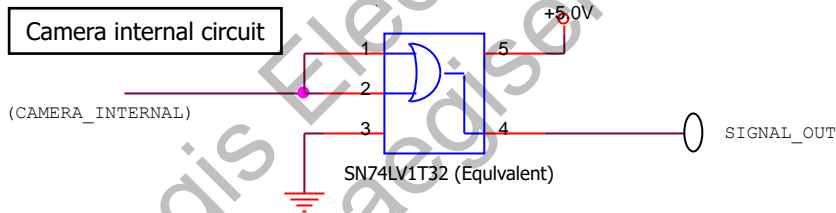

3.3. External Connector Pin Assignment

3.3.1 6pins Circular Connector HR10-10R-12PA(73) (HIROSE) or Equivalent

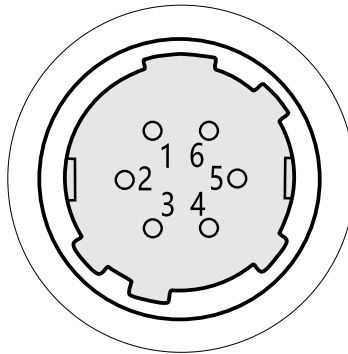

HR10A-7R-6PB (Hirose) or equivalent

Pin No.	Signals	Description
1	NC	
2	NC	
3	SIGNAL_OUT	Exposure/FVAL/LVAL/LinkTrigger
4	NC	
5	TRIGGER_IN	Trigger input
6	GND	Electrically connected with camera chassis.

※ NC=Non-Connection. Do not connect anything to the terminal.

3.3.2 75Ω BNC Connector

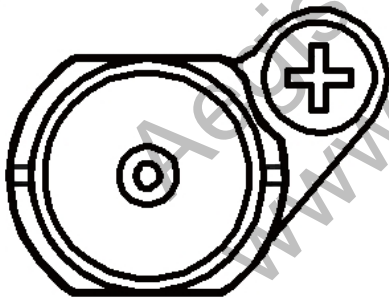

(BCJ-BPLHA CANARE)

3.3.3 LED Indicator

- With LED indicator Active, lighting patterns show the camera status by its way of lighting.

OFF	No power supply.
Green lighting	Completion of connection between device and host.
Green fast blinking [12.5Hz] ※	Transmitting video data.
Orange slow blinking [1Hz]	Waiting for a trigger input.
Red fast blinking [12.5Hz]	System error occurred.

- ※ When TriggerMode is Off, the LED will blink with 12.5Hz. When TriggerMode is On, the LED will blink in trigger cycle. (It may appear as lighted status at fast trigger mode.)

3.4. Spectral Response

- ※ Excludes characteristics of lens, IR cut filter, and light source.

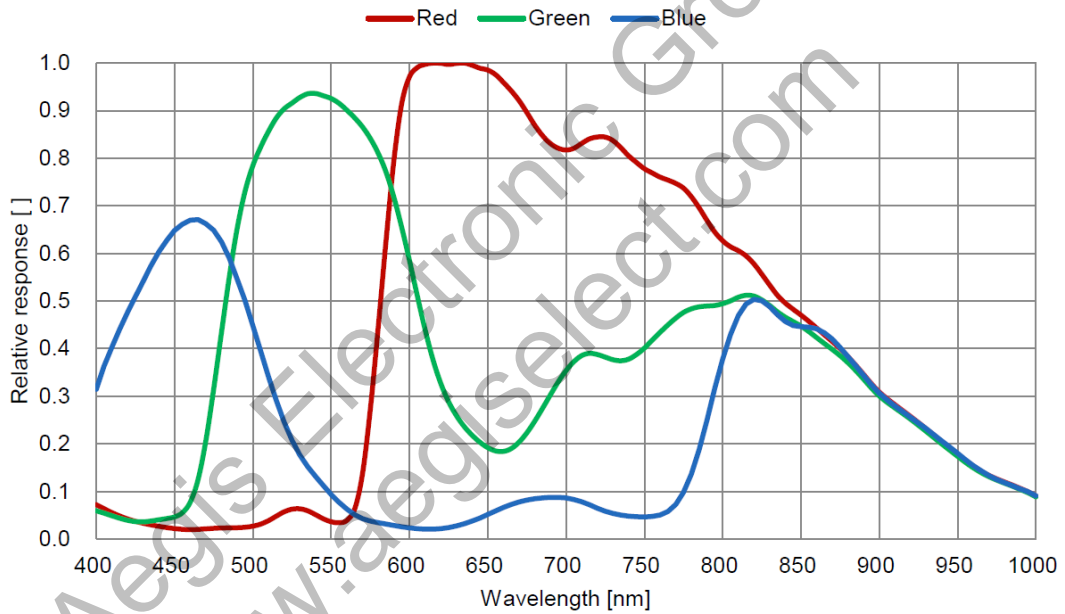

4. Output Timing

4.1. Horizontal Sync Timing

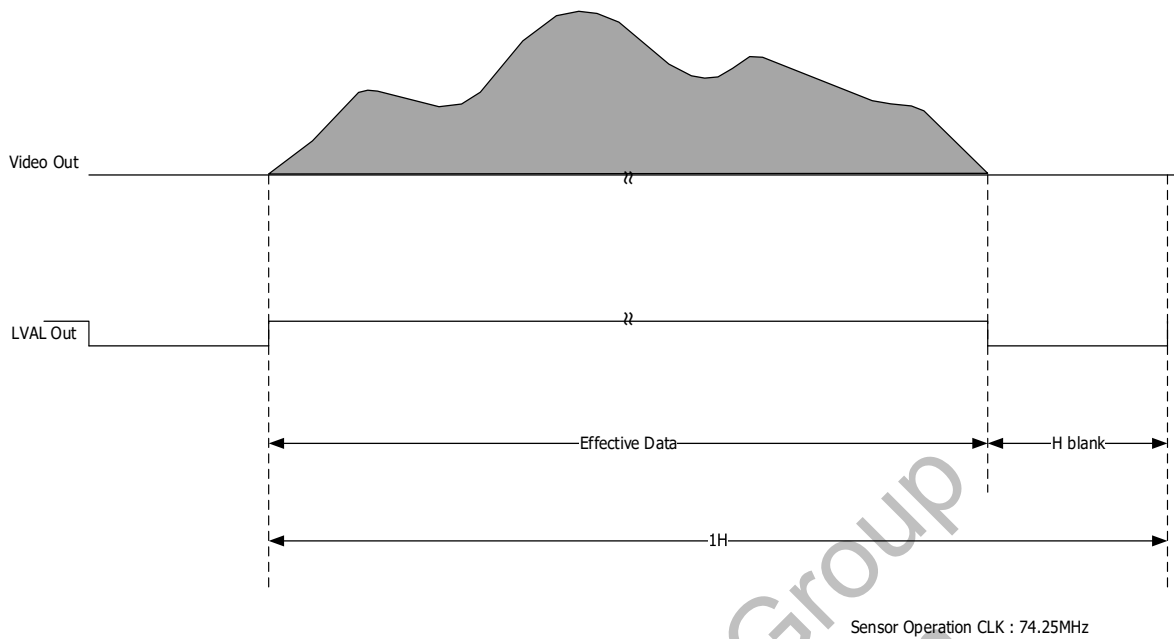

- ※ The time for 1H will change depends on the link rate and video output format.
- ※ The blanking pixel number for 1H will change depends on the link rate and video output format.

Effective pixel numbers and blanking pixel numbers

Link rate	Video output format	Effective Data	H blank	1H total pixel numbers	Time for 1H [us]
CXP-3	BayerRG/Mono8	204	268	472	6.36
	BayerRG/Mono10	204	376	580	7.81
	BayerRG/Mono12	204	480	684	9.21
CXP-6	BayerRG/Mono8	204	32	236	3.18
	BayerRG/Mono10	204	86	290	3.91
	BayerRG/Mono12	204	138	342	4.61

Sensor Operation clk 74.25 MHz

4.2. Vertical Sync Timing

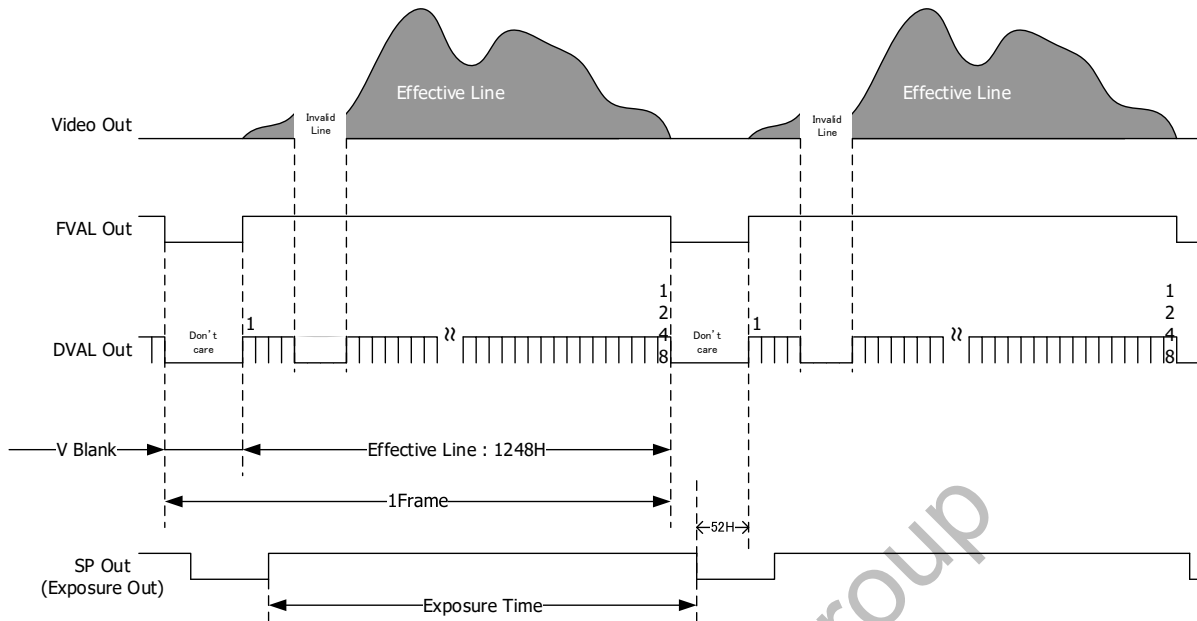

- ※ The time for 1 frame will change depends on the link rate and video output format.
- ※ The blanking line number for 1 frame will change depends on the link rate and video output format.

Effective line numbers and blanking line numbers

Link rate	Video output format	Effective line	V blank	1 frame total line number	Time for 1H [us]	Time for 1 frame [ms]
CXP-3	BayerRG/Mono8	1248	68	1316	6.36	8.37
	BayerRG/Mono10	1248	68	1316	7.81	10.28
	BayerRG/Mono12	1248	64	1312	9.21	12.08
CXP-6	BayerRG/Mono8	1248	68	1316	3.18	4.18
	BayerRG/Mono10	1248	68	1316	3.91	5.15
	BayerRG/Mono12	1248	64	1312	4.61	6.05

Sensor Operation clk 74.25 MHz

5. Camera Functions

5.1. Camera Interface

Complies with CoaXPress interface standard.

5.2. How to Save and Initialize Settings

UserSets	
UserSetSelector	Default UserSet0
UserSetLoad	Execute
UserSetSave	Execute

- Select UserSet0 with UserSetSelector and execute "UserSetSave" to save settings in operation into camera non-volatile memory.
  - ※ Settings are not subject to save to Default (factory settings).
  - ※ Values of UserSetSelector are not subject to save with UserSetSave. Please set values before executing UserSetLoad or UserSetSave.
- UserSetLoad loads Default (factory setting) or UserSet0 (user save area) selected with UserSetSelector.
  - ※ Do not execute UserSetLoad while grabbing (acquiring images).
- Defective pixel correction values and UserID are not subject to UserSetLoad for Default. (Camera keeps those values).
- ConnectionConfig, PixelFormat, and ImageQualityMode keep settings in operation even when executing UserSetLoad. Therefore, please set them with commands.

UserSetSelector	Default	UserSetLoad >Excute	= Initialize(Factory setting)
	UserSet0	UserSetLoad >Excute	= Initialize(User setting)
		UserSetSave >Excute	= User setting Save

5.3. Link Speed and Link Count

Transfer Control	
ConnectionConfig	CXP3_X1 CXP6_X1

- ◆ CXP-3: Link speed=3.125Gbps, Link count=1
- ◆ CXP-6: Link speed=6.250Gbps, Link count=1

※ Do not change ConnectionConfig while grabbing (acquiring images).

5.4. Pixel Format (RAW)

ImageFormatControl	
PixelFormat	BayerRG8 BayerRG10 BayerRG12 Mono8 Mono10 Mono12

- ◆ BayerRG8 : Bayer 8bit
- ◆ BayerRG10 : Bayer 10bit
- ◆ BayerRG12 : Bayer 12bit
- ◆ Mono8 : Monochrome 8bit
- ◆ Mono10 : Monochrome 10bit
- ◆ Mono12 : Monochrome 12bit

※ Do not change PixelFormat while grabbing (acquiring images).

5.5. Trigger Mode

5.5.1 Internal Sync Mode (Free Run Mode)

- This is a mode to use internal triggers continuously generated.
- Turn off TriggerMode and set TriggerSelector to AcquisitionStart.
- The table below shows frame rate when ROI is disabled.

PixelFormat	CXP6_X1	CXP3_X1
BayerRG/Mono8	239.0	119.5
BayerRG/Mono10	194.5	97.2
BayerRG/Mono12	165.4	82.7

5.5.2 External Trigger Sync Mode

- This is a mode to input external trigger signals to capture images by any preferred timings.
- Set TriggerSelector to AcquisitionStart and set TriggerSource to either Software/LinkTrigger0/Line0, and turn on TriggerMode.

Acquisition Control	
TriggerMode	On/Off
TriggerSyncMode	LineSync ClockSync
TriggerSelector	AcquisitionStart FrameStart
TriggerActivation	RisingEdge FallingEdge LevelHigh LevelLow
TriggerSource	Software LinkTrigger0 Line0
TriggerSoftware	Execute

- ◆ TriggerMode

- ◆ On : Enable trigger selected with TriggerSource. (TriggerSelector = FrameStart)
- ◆ Off : Disable trigger selected with TriggerSource. (TriggerSelector = AcquisitionStart)

※ Do not change Trigger Mode while grabbing (acquiring) images.

- ◆ TriggerSyncMode

- ◆ LineSync: H sync trigger mode (Control exposure time per line)  
Fixed/pulse width trigger shutter mode  
Overlapping operation (exposure while readout images) is valid.
- ◆ ClockSync: CLK sync trigger mode (Control exposure time per sensor clock)  
FAST fixed/FAST pulse width trigger shutter mode  
Overlapping operation (exposure while readout images) is invalid.

※ Switch TriggerSyncMode when there is no trigger input.

※ Set free run mode (internal sync) after set to LineSync mode.

- ◆ TriggerSelector

This is to select how to start capturing video or its polarity out of the followings.

- ◆ AcquisitionStart : Free run mode [Internal sync mode]
- ◆ FrameStart : External trigger mode

※ Do not change TriggerSelector while grabbing (acquiring) images).

- ◆ TriggerActivation

This is to select how to start capturing video or its polarity out of the followings.

- ◆ RisingEdge: Fixed trigger shutter mode: Rising edge (Timed)
- ◆ FallingEdge: Fixed trigger shutter mode: Falling edge (Timed)
- ◆ LevelHigh: Pulse width trigger shutter mode: High active (TriggerWidth)
- ◆ LevelLow: Pulse width trigger shutter mode: Low active (TriggerWidth)

- ◆ TriggerSource

This is to select where to send external triggers.

- ◆ Software: TriggerSoftware
- ◆ LinkTrigger0: External trigger input from CoaXPress Host Device.  
Please refer to specification manuals of the Host Device such as frame grabber board to know how to generate triggers.
- ◆ Line0: External trigger input from 6pins circular connector.

◆ TriggerSoftware: Software trigger

Camera generates a trigger to capture one frame image by executing this command.  
 Make sure to set TriggerSource to Software.

※ Software Trigger is valid when TriggerActivation is Rising Edge.

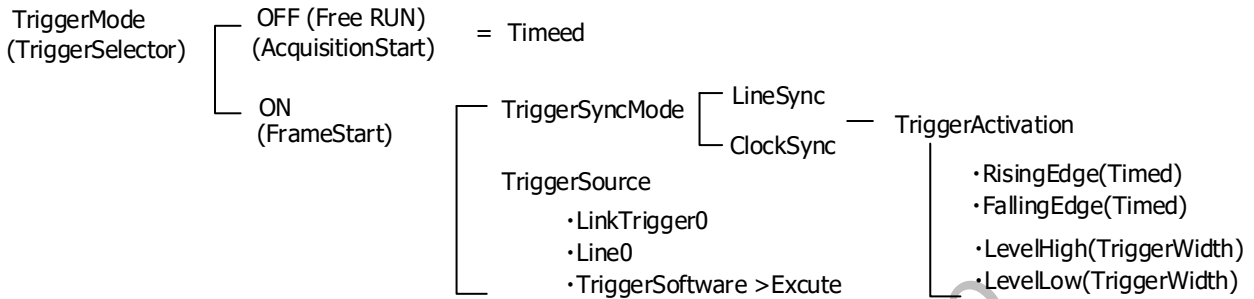

5.6. Trigger Sync Mode and Delay Time to Start Exposure

• H sync trigger mode (LineSync):

1H of jitter may occur from inputting trigger to exposure. (Overlapping operation is valid.)

• CLK sync trigger mode (ClockSync):

Less delay time from trigger input, and the precise trigger operation is valid. (Overlapping operation is invalid.)

Trigger sync mode and delay time to start exposure

	CXP6_X1	CXP3_X1
Delay Time to Start Exposure with H sync trigger (LineSync)	Approx. 4H~5H	Approx. 4H~5H
Delay Time to Start Exposure with CLK sync trigger (ClockSync)	Approx. 0.13us	Approx. 0.13us

5.7. Restrictions on Trigger Pulse Input Timing

- User can input a trigger for the next frame while camera is reading out signals. However, do not input a trigger pulse to end exposure while camera is reading out signals. In other words, a trigger pulse to start reading out signals for the next frame before completion of reading out signals for the prior frame is restricted.

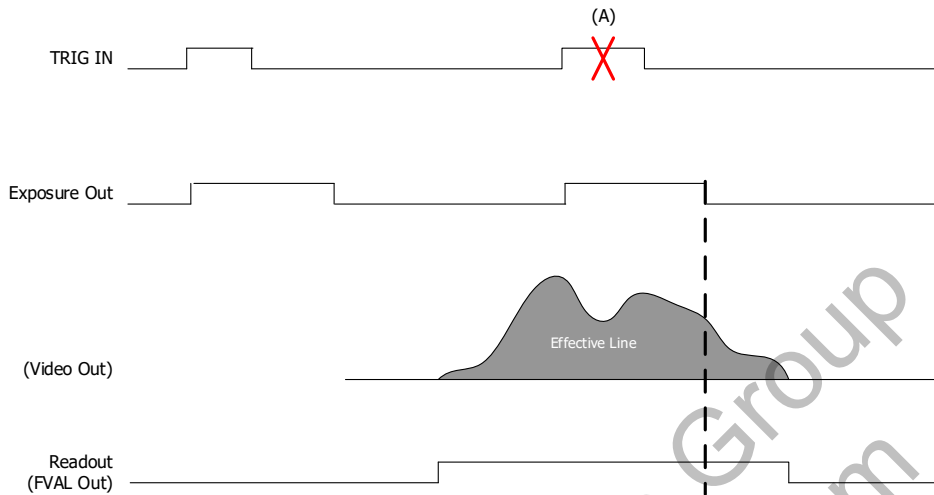

•If there is a trigger input with restricted timing explained in the above, "IllegalTriggerFlag" becomes "1".

Acquisition Control	
IllegalTriggerFlag	0 or 1

※ Since overlapping operation is invalid with CLK sync trigger mode, the trigger at this timing will be masked and "IllegalTriggerFlag" will not become "1".

Device Control	
ErrorFlagReset	Execute

This is to reset IllegalTriggerFlag to "0".

5.8. Fixed Trigger Shutter Mode (LineSync) H Sync Trigger

(TriggerMode=On, TriggerSyncMode=LineSync, TriggerActivation= RisingEdge)

- This is a mode to start exposure with external trigger input and expose for a set period.
- Trigger operation is H sync V sync reset.
- The delay time (Exposure Time Delay) from detecting trigger edge in the camera to starting exposure is 2H~3H.
- 1H jitter will occur to Exposure Time Delay since external trigger signal synchronizes with H inside the camera.
- Trigger pulse width to input must be longer than 1H. (Please refer to 1 line width for each mode in the table below.)

Link rate	Video output format	Time for 1H [us]
CXP-3	BayerRG/Mono8	6.36
	BayerRG/Mono10	7.81
	BayerRG/Mono12	9.21
CXP-6	BayerRG/Mono8	3.18
	BayerRG/Mono10	3.91
	BayerRG/Mono12	4.61

- There is an exposure time period for approx. **4.997μs** at the edge right after exposure output.

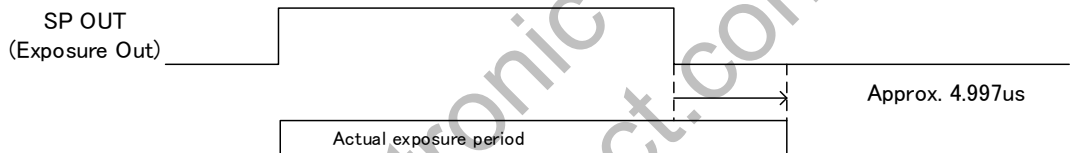

- User can input a trigger while camera is outputting images. However, do not input a trigger signal to start outputting next images before completion of outputting the prior images.
  - Trigger input while exposure period (Exposure Time) will be ignored in the camera. ((A) in the drawing below)
- Do not use a trigger shorter than 1 frame cycle.

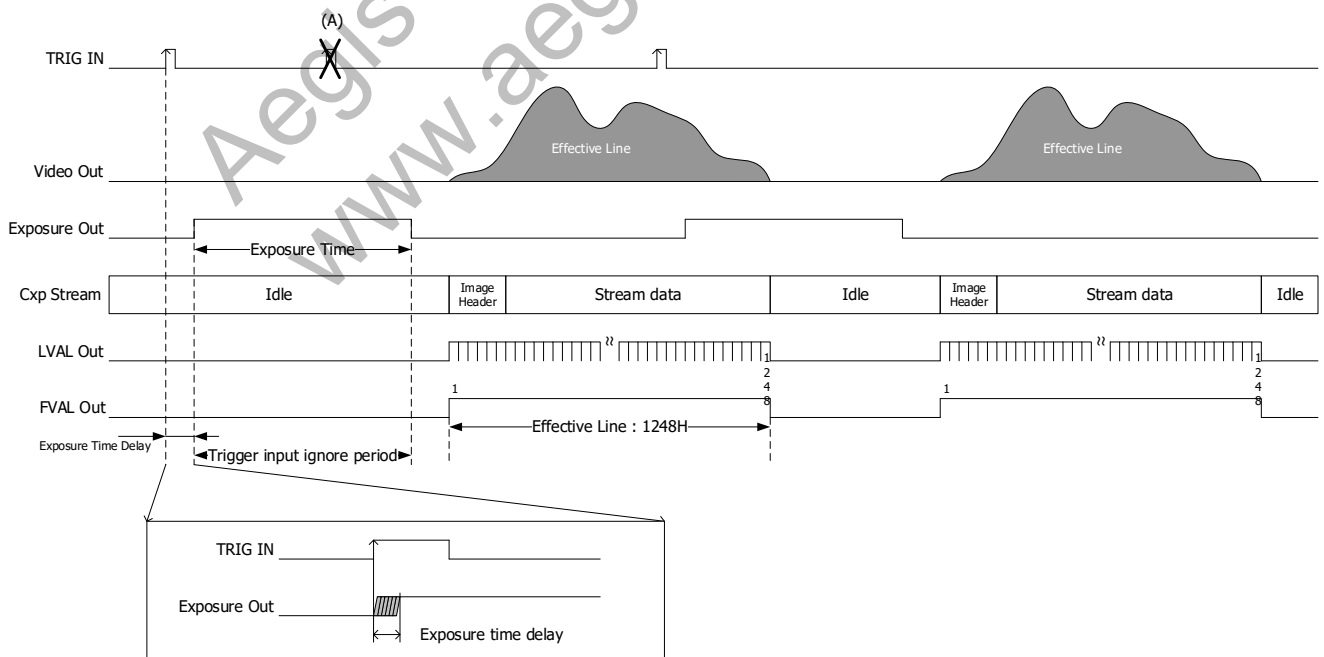

5.9. FAST Fixed Trigger Shutter Mode (ClockSync) CLK Sync Trigger

(TriggerMode=On, TriggerSyncMode=ClockSync, TriggerActivation= RisingEdge)

- This is a mode to start exposure with external trigger input and expose for a set period.
- Trigger operation is CLK sync V sync reset.
- The delay time (Exposure Time Delay) from detecting trigger edge in the camera to starting exposure is approx. 0.13μs.
- Trigger pulse width to input must be longer than 1μs.
- There is an exposure time period for approx. **4.997μs** at the edge right after exposure output.

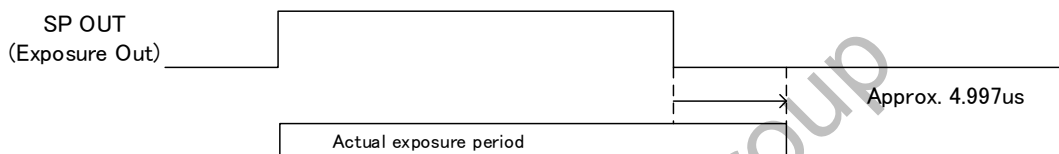

- The next trigger input while outputting images cannot be accepted.
- Trigger input while exposure period (Exposure Time) and readout period will be ignored in the camera. ((A) and (B) in the drawing below)

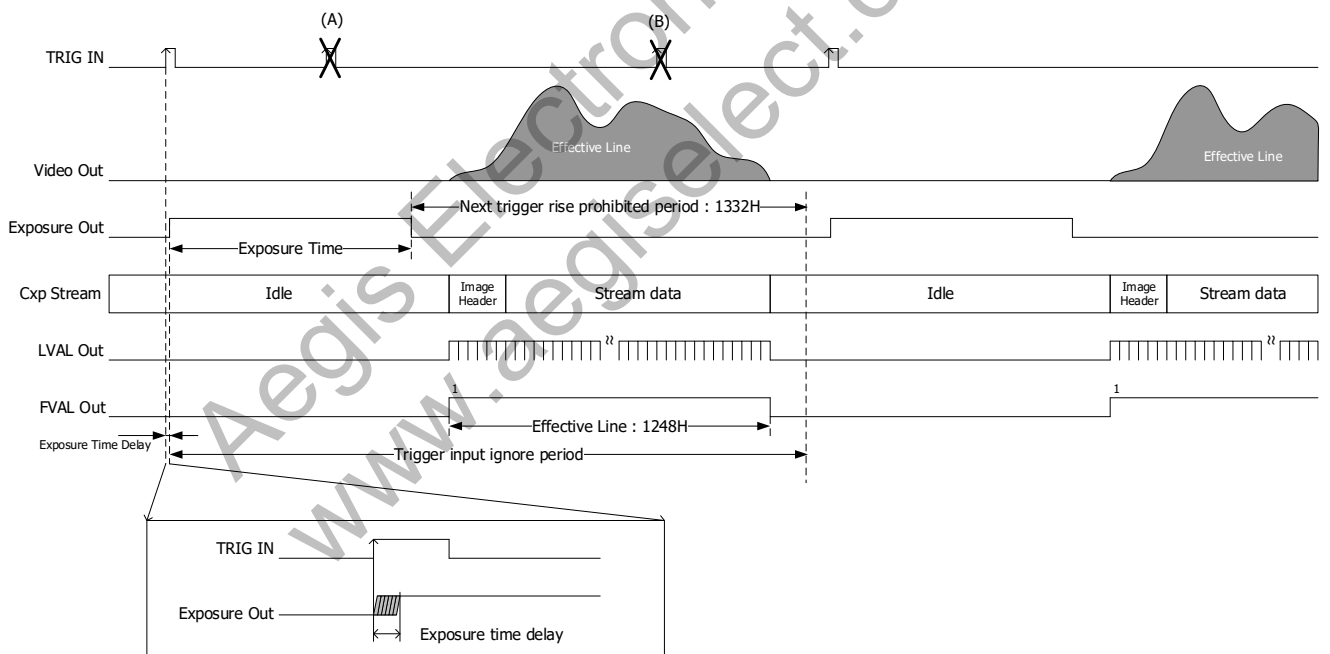

5.10. Pulse Width Trigger Shutter Mode (LineSync) H Sync Trigger  
(TriggerMode=On, TriggerSyncMode=LineSync, TriggerActivation=LevelHigh)

- This is a mode to start exposure with external trigger input and set exposure time with pulse width of trigger signals.
- Trigger operation is H sync V sync reset.
- The delay time (Exposure Time Delay①) from detecting trigger edge in the camera to starting exposure is  $4H \sim 5H$ .
- The delay time (Exposure Time Delay②) from detecting the trigger edge in the camera to end exposure is

**$4H + 4.997\mu s \sim 5H + 4.997\mu s$ .**

- Approx. 1H jitter will occur to Exposure Time Delay ① and ② since external trigger signal synchronizes with H inside the camera. Jitters may occur at both start and end edges of exposure with pulse width trigger shutter mode. At this time, exposure time will change so that flicker may be shown in the image, especially when high speed shutter is set. This flicker sometimes can be eliminated with fixed trigger shutter mode. However, this problem can be solved by inputting trigger pulse with synchronizing it to the camera H cycle (LVAL).
- Pulse width 1H (Min.) ~ Approx. 2 frames  
Functionally, there is no upper limitation, but noises such as dark noise shadings may be noticeable at long time exposure.
- There is an exposure time period for approx.  **$4.997\mu s$**  at the edge right after exposure output.



- Trigger input while exposure period (Exposure Time) will be ignored in the camera. Do not use a trigger shorter than 1 frame cycle.
- User can input a trigger while camera is outputting images.  
However, do not input a trigger signal to start outputting next images before completion of outputting the prior images. ((A) in the drawing below)

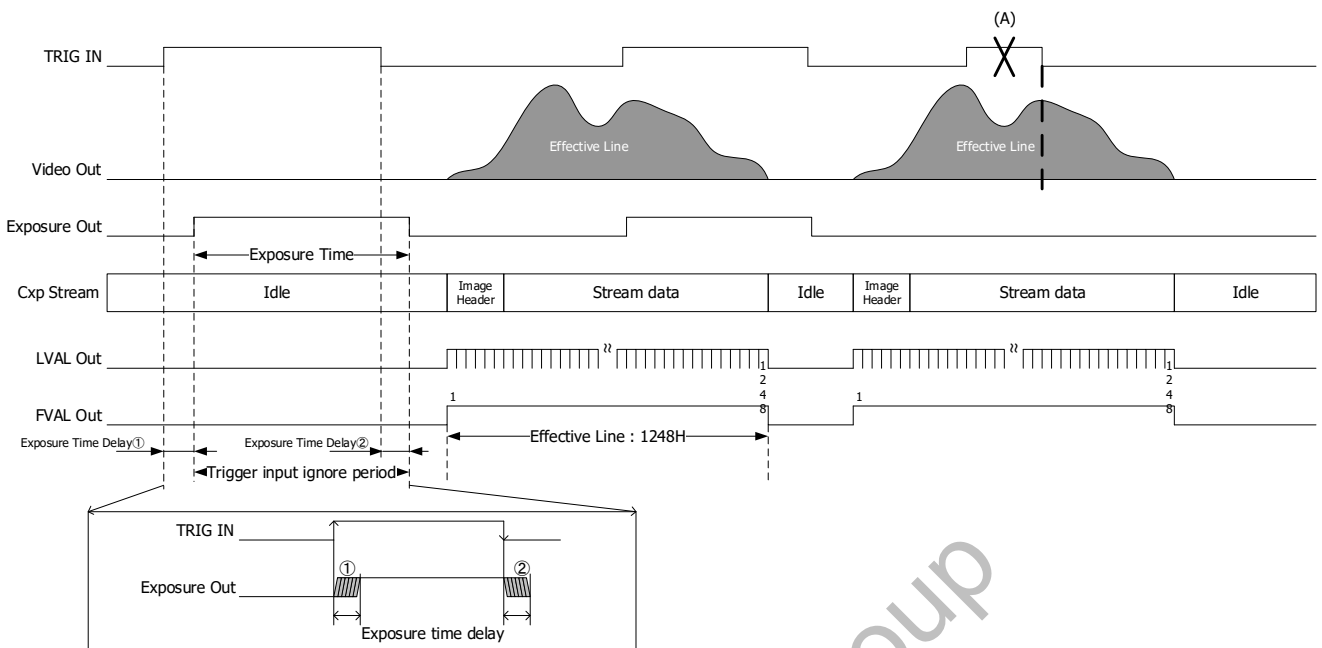

5.11. FAST Pulse Width Trigger Shutter Mode (ClockSync) CLK Sync Trigger  
 (TriggerMode=On, TriggerSyncMode=ClockSync, TriggerActivation=LevelHigh)

- This is a mode to start exposure with external trigger input and set exposure time with pulse width of trigger signals.
- Trigger operation is CLK sync V sync reset.
- The delay time (Exposure Time Delay①) from detecting trigger edge in the camera to starting exposure is approx. 0.13μs.
- The delay time (Exposure Time Delay②) from detecting trigger edge in the camera to end exposure is approx. 4.997μs.
- Pulse width 0.74μs (Min.) ~ Approx. 2 frames  
 Functionally, there is no upper limitation, but noises such as dark noise shadings may be noticeable at long time exposure.
- There is an exposure time period for approx. **4.997μs** at the edge right after exposure output.

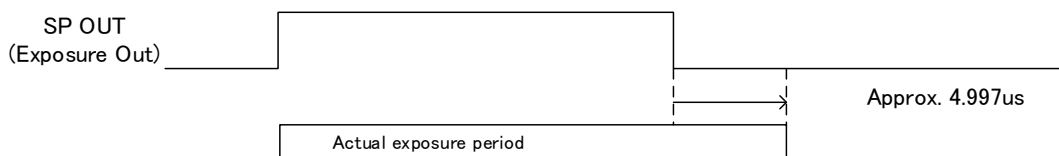

☐ Trigger input while readout period will be ignored in the camera. ((A) in the drawing below)

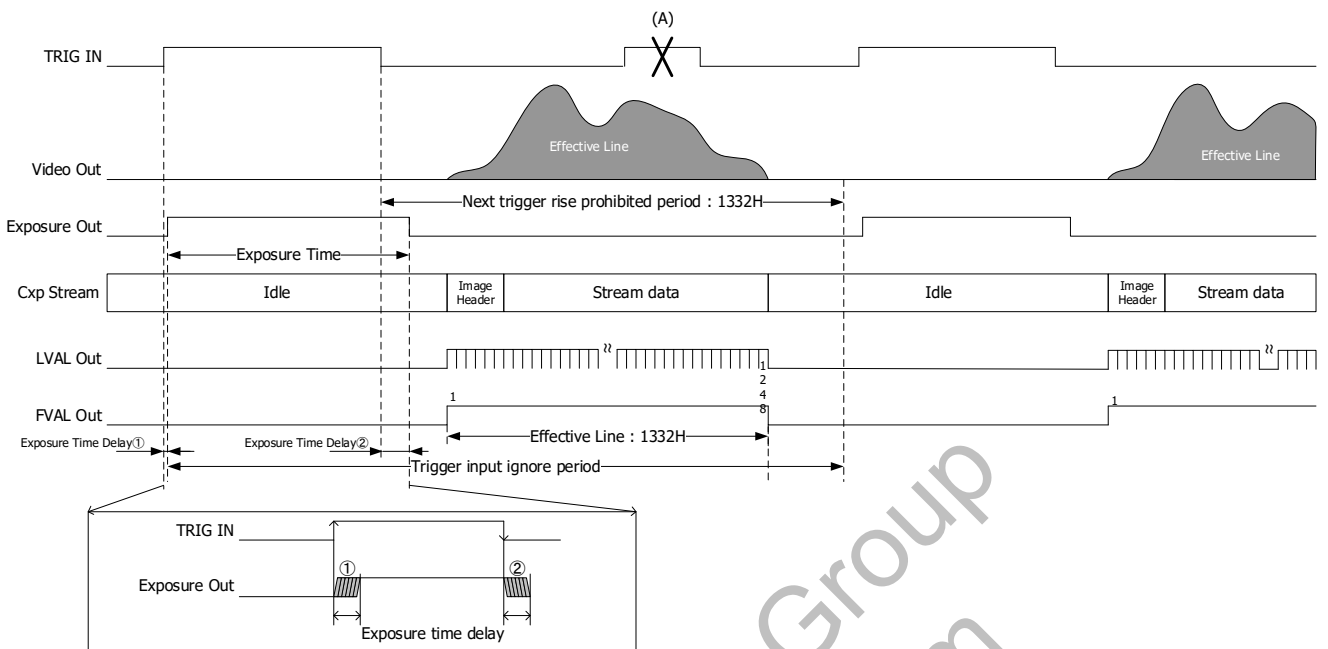

5.12. Exposure Time

Acquisition Control	
ExposureMode	Timed TriggerWidth
ExposureTime (us)	5us~Max. exposure time: LineSync 10uS~200ms: ClockSync
ExposureTimeMax	(ReadOnly)

ExposureMode (Read only): This is to check if current mode is Timed or TriggerWidth (PWC).

ExposureTime: Exposure time (Valid when ExposureMode is Timed.)

- Set per 1H when the trigger operation is H sync. It will return the value (us) rounded by 1H per Min. 1H mode.
- Set per approx. 1us when the trigger operation is CLK sync.

ExposureTimeMax: Max. exposure time

- Set the smaller value than ExposureTimeMax when the camera is internal sync mode. It will depend on partial scan (ROI) settings, PixelFormat, and link rate.

- ※ The maximum of H sync trigger mode (LineSync) will be clipped with effective line count (Including when the camera is set to ROI).
- ※ CLK sync trigger mode (ClockSync) can be set in the range of 10us~200ms. It will not be clipped with effective line count.

## 5.13. Formula to Calculate Manual Shutter Values with H Sync Mode

The value will be corrected to the value corresponds to the following formula.

Formula: Exposure time = Time for 1 line (Please refer to the table below) × Exposure line count + **4.997μs**

Link rate	Video output format	Time for 1H [us]
CXP-3	BayerRG/Mono8	6.36
	BayerRG/Mono10	7.81
	BayerRG/Mono12	9.21
CXP-6	BayerRG/Mono8	3.18
	BayerRG/Mono10	3.91
	BayerRG/Mono12	4.61

- ※ The Min. setting value will be clipped with 1, and the Max. value will be clipped with 1248 or with the total line count of partial mode.

## 5.14. Manual Shutter Settings with CLK Sync Mode (FAST Trigger Mode)

Exposure time = Setting value + **4.997μs**

•Min. setting value: **10μs** (Approximate value)

•Max. setting value: **200ms** (Approximate value)

※ Unlike H sync mode, exposure time will not be clipped with total line count, etc.

※ Bright point may be noticeable with long time exposure.

•Setting unit: 1μs (Approximate value) ※Slight differences may occur since it is generated by 74.25MHz.

## 5.15. Gain

AnalogControl	
Gain	Manual

User can set gain value in the range of x1.00~x256.00.

However, with high gain settings, noise will increase and image quality deteriorates.

## 5.16. Gamma Correction

AnalogControl	
Gamma	0.10~1.80

Gamma: This is to set gamma correction value per 0.01 step.

[Note]

Camera updates gamma table at the timing of image output. With continuous operation mode, camera applies the updated gamma table at the timing of image output after completion of rewriting gamma table (approx. 20ms: refer to Command ACK as a rough guide)

If user changes gamma coefficient while waiting for a trigger input, camera outputs images with updated gamma table with a trigger after completion of rewriting gamma table.

## 5.17. Partial Scan (ROI)

- This is to increase frame rate by cutting and reducing read out area.
- It will be Idle output when RegionMode of Region 1~8 are all OFF.
- User can select up to 8 areas for partial area.

<b>ImageFormatControl</b>	
RegionSelector	EffectiveRegion , Region1~8
RegionMode	On/Off
RegionDestination	Stream0
Width	1632
Height	8~1248 (Multiples of 8)
OffsetX	0
OffsetY	0~1240 (Multiples of 8)

- RegionSelector: This is to select Region to set.  
User can set 8 partial areas with Region 1~8. Select EffectiveRegion to check Width and Height of the effective partial area.  
  
※ Make sure to set RegionSelector to EffectiveRegion to start capturing images.
- RegionMode: On/Off of the Region1~8. User can check if there is an effective region with EffectiveRegion.  
※ Enabled only when Width, Height, OffsetX, and OffsetY are effective.
- RegionDestination: Selection of Stream to output. Fixed with Stream0.
- Width: Width of Region. This model VCC-2CXP6R is fixed to 1632.
- Height: Height of Region.  
※ Make sure that OffsetY and Height do not overlap with other regions.
- OffsetX: Offset for X direction of Region. This model VCC-2CXP6R is fixed to 0.
- OffsetY: Offset for Y direction of Region.  
※ Make sure that OffsetY and Height do not overlap with other regions.

In case of setting 3 partial areas:

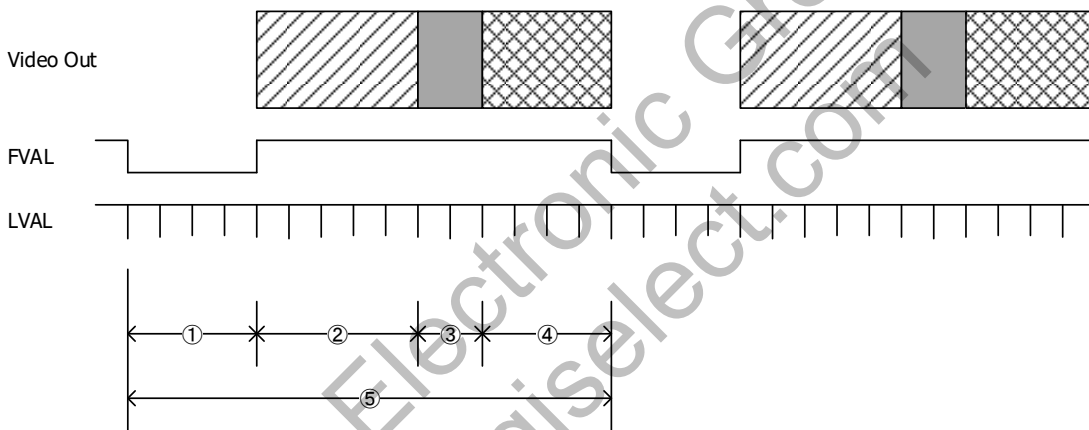
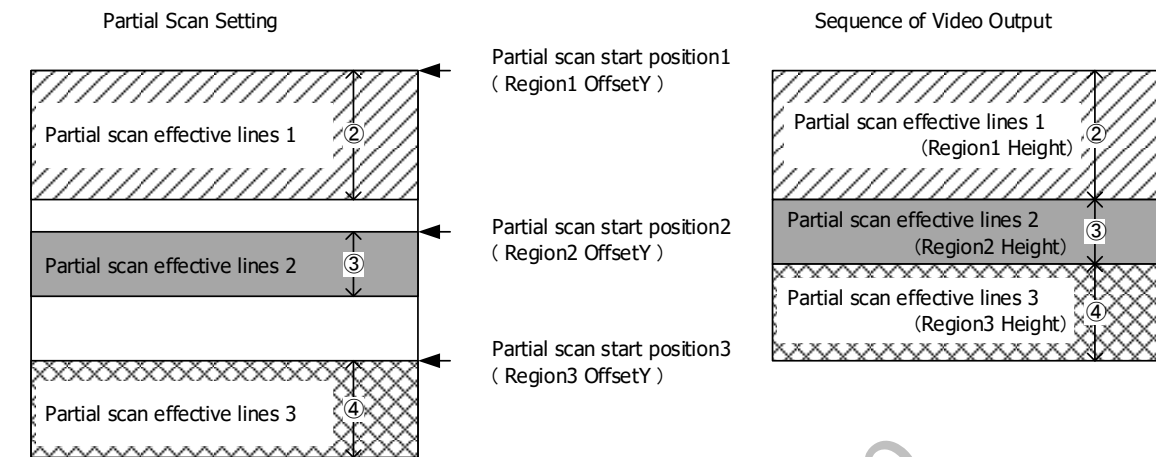

- ① : V blanking line
- ② : Partial area 1
- ③ : Partial area 2
- ④ : Partial area 3
- ⑤ : Total line count per frame

When setting several partial scan areas, make sure that start positions and effective lines do not overlap each area.

$$\square \text{ Total line count per frame} = \text{V blanking lines} + \text{Partial effective line 1} + \text{Partial effective line 2} + \dots + \text{Partial effective line 8}$$

However, make sure that sum total of partial effective line numbers from 1~8 (except V blanking lines) is less than 1248.

V blanking lines will be **64 or 68H** with partial mode.

- Frame rate = 1 / (Total line count per frame × Time for 1 line)

Time for 1 line

Link rate	Video output format	Time for 1H [us]
CXP-3	BayerRG/Mono8	6.36
	BayerRG/Mono10	7.81
	BayerRG/Mono12	9.21
CXP-6	BayerRG/Mono8	3.18
	BayerRG/Mono10	3.91
	BayerRG/Mono12	4.61

- The line numbers with partial scan setting can be set from 8 lines. Only multiple numbers of 8 can be set.
- With partial scan, the effective line count of manual shutter setting becomes the maximum value (except at ClkSync trigger).
- When switch between Full frame scan mode and Partial scan mode, or changing partial settings, 1 frame after the change will be invalid.

**Especially with fixed trigger shutter mode and pulse width trigger shutter mode, input a dummy trigger first, then use subsequent triggers as actual video signals.**

#### 5.18. White Balance

AnalogControl	
BalanceRatioSelector	Red Blue
BalanceWhiteAuto	Off Once
BalanceRatio	0.00~8.00

- ◆ BalanceWhiteAuto: This is to adjust white balance gain automatically.
  - ◆ Off : Waiting
  - ◆ Once : Adjust white balance automatically with one push.

Select "Once" of BalanceWhiteAuto to adjust white balance automatically and return to off.

BalanceRatio shows new gain of color component selected with BalanceRatioSelector.

Shoot an object with achromatic color to full screen to execute BalanceWhiteAuto. Recommendation is approx. 50% of signal level to execute.

※Set RegionSelector to EffectiveRegion to execute "Once" of BalanceWhiteAuto.

※More than 2 partial areas disable BalanceWhiteAuto.

Enables the following commands only when BalanceWhiteAuto is OFF.

- ◆ BalanceRatioSelector : This is to select the color component you wish to change with BalanceRatio.
- ◆ BalanceRatio : This is to set gain in the range of x0 ~ x8.

If user set Red with BalanceRatioSelector, set BalanceRatio to 1.0, then change BalanceRatioSelector to Blue, and set BalanceRatio to 1.0, white balance becomes invalid.

## 5.19. Black Level Adjustment

- This is to adjust black level of image sensor.

AnalogControl	
BlackOffset	-64~63

[Note]

This is not a function to set absolute value of black level.

Black level of image sensor can be changed proportionally.

This is a value converted by 12bit. The value will be equivalent to  $\pm 16$  with 10bit, and equivalent to  $\pm 4$  with 8bit.

User can change setting values while capturing images. However, disturbance images may occur.

## 5.20. Image Quality Selecting Mode

- This is to select image quality of output image.

AnalogControl	
Image Quality Mode	StandardMode LowNoiseMode LowFrameRateMode

- ◆ Image Quality Mode: Image quality selecting mode
- ◆ StandardMode: Standard mode
- ◆ LowNoiseMode: SN will be improved compared to StandardMode, however the sensitivity will be decreased.
- ◆ LowFrameRateMode: SN will be improved compared to LowNoiseMode, however frame rate and sensitivity will be decreased. Valid only with Mono8 and BayerRG8.

## 5.21. Defective Pixel Correction

- This is a function to detect and correct defective pixels in output data from the sensor.
- There are two types of defective pixel data.
  - Defective data registered at factory  
Black and white defective pixel data registered upon shipment from our factory. These data cannot be over-written.
  - Defective data registered by user  
Data registered by user. In addition to the correction of defective pixel data registered upon shipment, we provide a method to update the defective pixel data. With DefectPixelDefault command, user can delete these user-registered data.

- User can register up to 128 points. (Note: Up to 32 points per CH.)

[CH (Channel)]

Camera performs image processing with 4CH interleave.

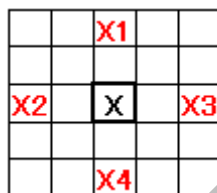
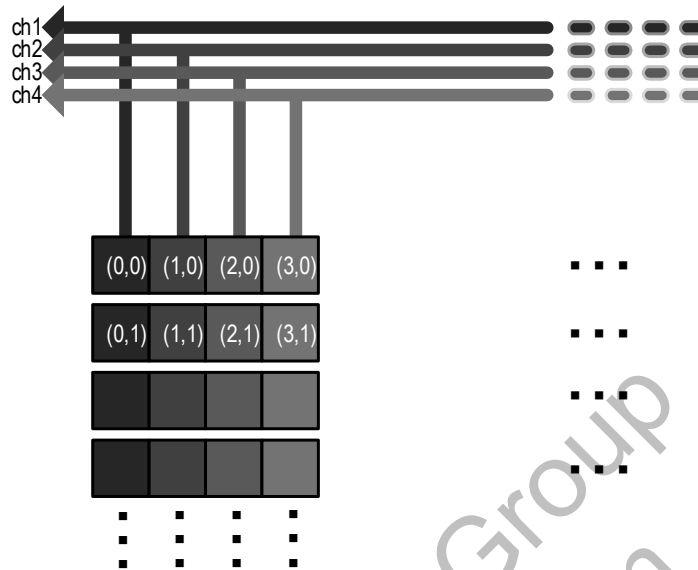

Defective pixel correction function calculates value for X pixel referring to peripheral pixels (up and down, left and right). When all peripheral pixels, X1, X2, X3, and X4, are already registered as defective pixels, user cannot correct the X pixel.

- How to control defective pixel correction

This is to turn ON/OFF defective pixel correction processing.

Defective pixel correction data at factory and defective pixel correction data registered by user will be both controlled at the same time.

AnalogControl	
DefectPixelCorrection	On/Off
DefectPixelAdd	(Execute)
DefectPixelAddOffsetY	0~1247
DefectPixelAddOffsetX	0~1631
DefectPixelDelete	(Execute)

- Defective data registered by user

This is to add the designated X and Y coordinate.

Any preferred pixels can be registered and deleted as defective pixels by designating coordinates.

- DefectPixelCorrection: This is to select valid/invalid of defective pixel correction.
- DefectPixelAddOffsetY: Designate Y coordinate
- DefectPixelAddOffsetX: Designate X coordinate
- Please execute DefectPixelAdd to register the designated coordinate as a defective pixel correction point.
- Please execute DefectPixelDelete to delete the designated coordinate registered as defective pixel correction point.

- ◇ Defective pixel correction cannot be enabled while binning.
- ◇ If the coordinate same as defective data at factory is designated, it will be ignored.
- ◇ Only the defects added by "Defective pixel detection registered by user" or "Defective pixel added by user" can be deleted. Factory setting data cannot be deleted by this command.

□ Defective pixel detection registered by user

This is to detect and register correction data of white defect caused by image sensor.

<b>AnalogControl</b>	
DefectDetectionThesholdValue	0~4095
DefectDetection	(Execute)
DefectDetectionStatus	(ReadOnly)
DefectPixelDefault	(Execute)
DefectCorrectMode	Reacquire/Add

◆ DefectDetectionThesholdValue:

This is to set a threshold value (0~4095: 12bit conversion) for user defective pixel detection. Data which exceeds the luminance level designated here will be registered.

With 8bit images, designate a value of 16 times of signal level as a threshold value.

◆ DefectDetection:

This is to detect defective pixels registered by user.

Function automatically registers pixels that exceed the level designated with DesignefectDetectionThresholdValue. Make sure to shield light from image sensor to execute. Function reflects defective pixel correction registered by user immediately after execution. Execute UserSetSave after DefectDetection to save data into non-volatile memory.

◆ DefectDetectionStatus:

This is to indicate results of defective pixel detection proceeded by user.

0 Value (128 or less)	No defective pixel correction data registered by user. When the function is operated normally. (Number of defective pixels detected and registered by user.)
0x000e0001 (917505)	Total number of defective pixel correction data exceeds the maximum number to register. (128 points)
0x000e0002 (917506)	Total number of defective pixel correction data exceeds the maximum number to register in one CH. (32)

When the value 129 or more is indicated, check if user threshold value (DefectDetectionThresholdValue) and the indication of defective pixels are appropriate.

※Please note that error may be indicated in decimal.

- ◆ DefectPixelDefault : This is to delete entire defective pixel correction data registered by user.
- ◆ DefectCorrectMode : This is to select detection mode of defective pixels out of the followings.

Reacquire mode: This mode deletes defective pixel data except those added by one point addition and reacquire defective pixels.

Add mode: This mode acquires defective pixels in addition to the current pixels registered.

## [Note]

- ♦ Make sure to acquire defective pixel correction data when camera is in operation.
- ♦ Make sure to turn OFF partial scan or binning mode to detect defective pixels. (Size must be 1632 x 1248 to execute).
- ♦ To acquire user defective pixel correction data by changing threshold value of DefectDetectionThresholdValue, execute DefectPixelDefault first to delete defective pixel correction data registered by user and reacquire it.
- ♦ Maximum number of defective pixels to register and to correct may not always be the same due to following reasons.
  - (1) With white defects detection, if one of interleave channel reaches the maximum number of defective pixels to register, correction stops. Function registers data up to that point, outputs error, and ends its operation.
  - (2) When there is no effective pixel around the pixel to add (on the left, right, top, and bottom), user can register but cannot correct that pixel.

## □ Indication of defective pixel coordinates

This is to indicate the coordinates of defective pixels registered by user.

AnalogControl	
RegisteredDefectSelector	UserState/InitialState
DefectPixelNumber	1~128/1~384
DefectPixelOffsetY	(ReadOnly)
DefectPixelOffsetX	(ReadOnly)
DefectPixelType	(ReadOnly)

- ♦ RegisteredDefectSelector : This is to select the types of registered defects.
- ♦ DefectPixelNumber : This is to designate a table number of the defective data registered at factory and by user.
- ♦ DefectPixelOffsetY : This is to indicate Y coordinate of the defective pixel designated with DefectPixelNumber. When user designated a table number with no defective pixel data, it shows 65535.
- ♦ DefectPixelOffsetX : This is to indicate X coordinate of the defective pixel designated with DefectPixelNumber. When user designated a table number with no defective pixel data, it shows 65535.
- ♦ DefectPixelType : This is to indicate the types of defects designated with DefectPixelNumber.
  - 1: White defects registered upon shipment from factory
  - 2: Black defects registered upon shipment from factory
  - 6: Defects registered by user
  - 7: Defects additionally registered by user
  - 65535: Table without defects

AnalogControl	
ChannelNumber	1~4
DefectPixelChannelCount	(ReadOnly)

- ◆ ChannelNumber: This is to designate channel number of defective pixel processing.
- ◆ DefectPixelChannelCount: Indicate the number of defective pixels for the channel designated with ChannelNumber.  
The number of defective pixel of the designated channel number is the sum total of defective pixel number upon shipment and the number of defective pixels registered by user.

5.22. Test Pattern Indication

- This is to output test pattern from camera. This is useful to check if your system is operating properly.

ImageFormatControl	
TestPattern	Off ColorBar

※ Test pattern indication cannot be used when cursor is indicated.

5.23. Cursor Indication

- This is to indicate cursor on your display screen.

ImageFormatControl	
CursorPattern	Off/On
CursorOffsetX	X coordinate
CursorOffsetY	Y coordinate
CursorColor	White/Black

※ Cursor indication cannot be used when test pattern is indicated.

- CursorPattern: Cursor indication On/Off.
- CursorOffsetX: X coordinate of vertical cursor.
- CursorOffsetY: Y coordinate of horizontal cursor.
- CursorColor: This is to select the color of cursor. (black or white)

5.24. LED Operational Mode

- This is to change operational mode of LED at the rear of camera. For information on lighting patterns, refer to [Section 3.3.3. LED Indicator](#).

DeviceControl	
DeviceIndicatorMode	Active ErrorStatus Inactive

- Active : Indication of communication status of CoaXPress.
- ErrorStatus : OFF with normal operation. Lights only with system error.
- Inactive : ALL LED OFF

5.25. Camera Timing Output

- According to LineSource settings, camera outputs the following signals through pin No. 3 of 6pins circular connector.

Digital IO Control	
LineSelector	Line0
LineMode	Output
LineSource	OFF ExposureActive FrameActive LineActive TriggerPacketActive

•LineSource

- ExposureActive                      This is to indicate exposure period of image sensor with Hi Active.
- FrameActive                            This is to indicate effective period of frame with Hi Active.
- LineActive                              This is to indicate effective period of video output line with Hi active.
- TriggerPacketActive                  This is to decode and output packet signals of uplink trigger from frame grabber.

5.26. User ID

- Set a letter string as DeviceUserID with up to 16 characters including NUL letter ( ). Execute UserSetSave to save these letter strings to camera non-volatile memory. These data will be kept even executing "UserSetLoad" with "Default."

DeviceControl	
DeviceUserID	Manual

5.27. Temperature Indication

- This is to indicate temperature of image sensor ( C).

DeviceControl	
DeviceTemperature	ReadOnly

[Note]

The value of register is not calibrated. Please regard it as reference value.

## 6. Factory Settings

Function	Data	Descriptions
TriggerSelector	AcquisitionStart	Equivalent to TriggerMode=Off
TriggerMode	Off	Operate with TriggerSelector at the same time.
TriggerSyncMode	LineSync	Horizontal sync mode
TriggerSource	LinkTrigger0	UP link trigger
TriggerActivation	RisingEdge	Rising edge
ExposureTime	7938.0	7.938ms
Gain	1.00	x1.00
Gamma	1.00	Gamma coefficient=1.00
DefectPixelCorrection	On	Defective pixel correction On/Off
DefectPixelAddOffsetX	0	X coordinate of defective pixel
DefectPixelAddOffsetY	0	Y coordinate of defective pixel
DefectDetectionThesholdValue	50	Threshold value of defective pixel detection
BlackOffset	0	Black level initial value
PixelFormat	BayerRG8	RAW model
ConnectionConfig	CXP3_X1	CxpLinkConfiguration
TestMode	NomalOperation	Link test Off
RegionSelector	EffectiveRegion	Specify the number for partial area (ROI) (Region1)
RegionMode	On	Partial area (ROI) operation On/Off
Height	1248	Specify height of Partial area (ROI)
OffsetY	0	Specify the start position of partial area (ROI)
TestPattern	Off	Cannot use cursor indication at the same time.
CursorPattern	Off	Cannot use test pattern at the same time.
CursorOffsetX	816	Position of cursor X
CursorOffsetY	623	Position of cursor Y
CursorColor	White	Cursor color White/Black
BalanceRatioSelector	Red	RAW model
BalanceWhiteAuto	Off	RAW model
DeviceIndicatorMode	Active	Display LED indicator
LineSource	Off	Circular 6P-3pin output setting
DeviceUserID		User set letter string (16 letters)

7. Dimensions

7.1. Camera Dimensions

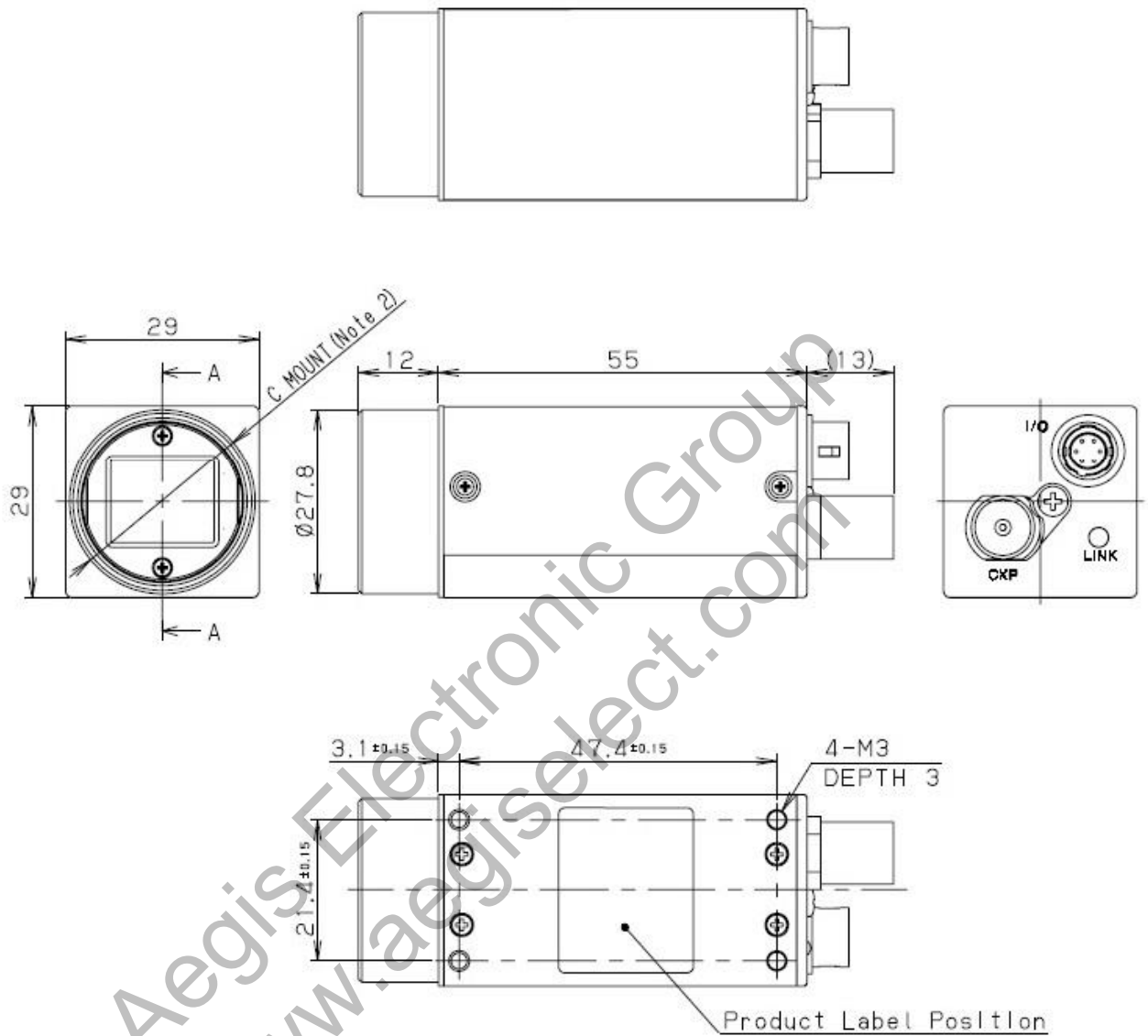

Note2) C mount screws comply with ANSI/ASME B1.1.1-32UN (2B).

Note1) Screw length from the lens mount surface shall be less than 6 mm. And protruding portion of the C mount lens shall be less than 10 mm.

935-0188-00  
(Unit:mm)

7.2. Optical Axis Accuracy

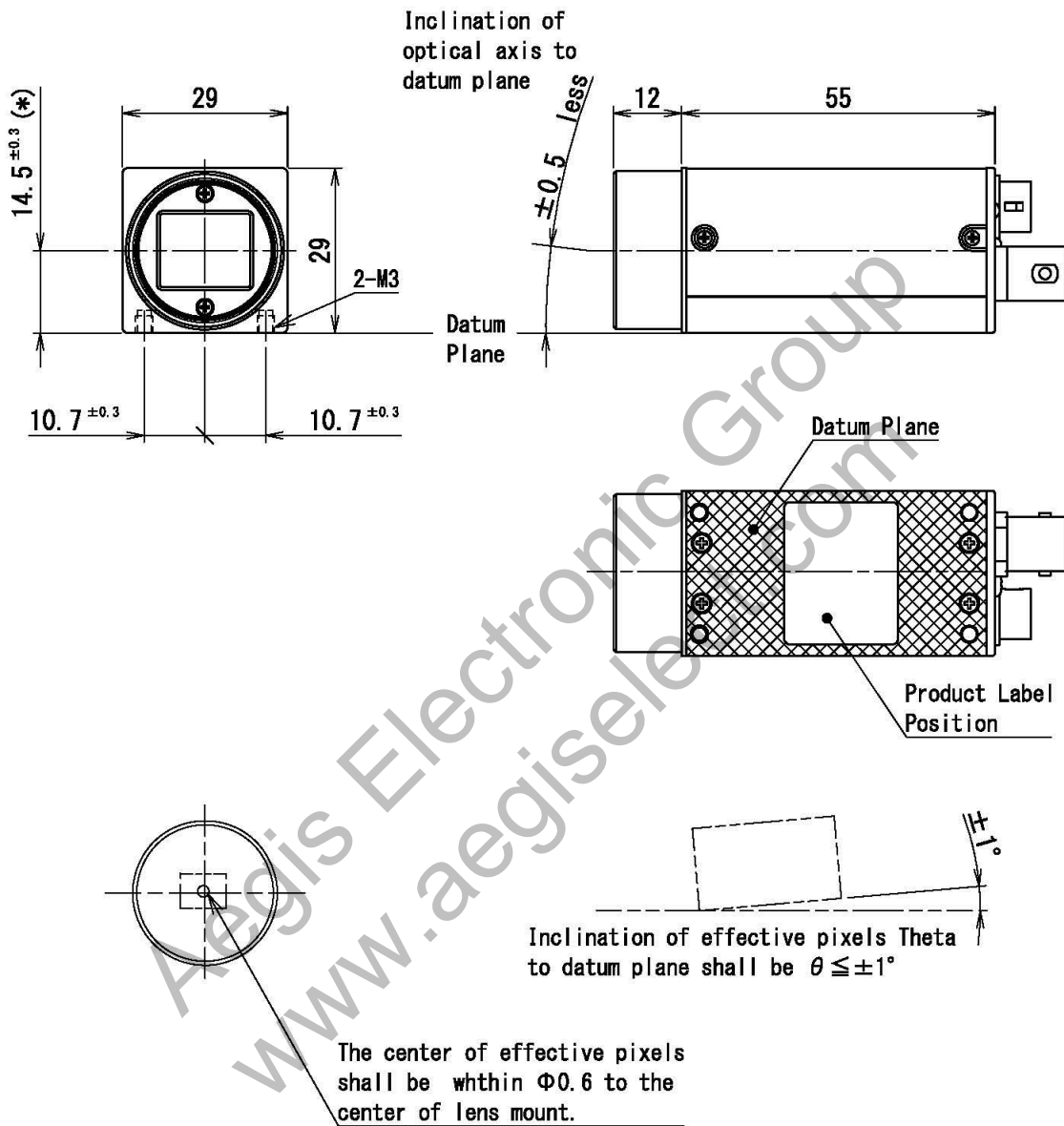

(\*)Dimension from datum plane to the center of lens mount.

937-0012-00  
(Unit:mm)

## 8. Case for Indemnity (Limited Warranty)

### 8.1. Product Warranty

The term of warranty of this product is within 3 years from the date of shipping out from our factory.

If you use the product properly and discover a defect during the warranty period, and if that was caused by designing or manufacturing, CIS Corporation, at its option, repairs or replaces it at no charge to you. Products out of warranty period will be subject to charge.

CIS should not hold responsible for damages or losses if;

- damages or losses are caused by earthquake, lightning strike, fire, flood or other acts of God.
- damages or losses are caused by deliberate or accidental misuse by user, or failure to observe the information contained in the instructions in this Product Specification and Operational Manual.
- damages or losses are caused by repair or modification conducted by customer or any unauthorized party.

### 8.2. CMOS Defective Pixels

CIS applies defective pixel correction prior to the shipment of the product. However, the number of defective pixels are subject to increase due primarily to the effect of cosmic rays. Due to this nature, CIS should not hold responsible for the natural increase of defective pixels.

### 8.3. Product Support

Should you have any problems in function of the product you purchased, and if you need our further analysis and/or repair, please contact your local distributor.

Aegis Electronic Group  
www.aegiselect.com