

CIS

**Camera Link I/F
12M Pixels CMOS
Color (RAW) Camera**

VCC-12CL4R

**Product Specifications
& Operation Manual**

CIS Corporation

Table of Contents

	PAGE
1. Handling Precautions	3
2. Product Outline	4
3. System Configuration	4
3.1. Camera	4
3.2. Optional Accessories	4
3.3. Free Software	4
3.4. Packaging	4
4. Specifications	5
4.1. General Specifications	5
4.2. Input and Output Signals Specifications	6
4.3. CMOS Spectral Response ※The lens characteristics and illuminant characteristics are excluded.	7
4.4. Video Output Format	7
5. Camera Function Settings	9
5.1. The List of Preset Shutter	11
5.2. Formula to Calculate Manual Shutter Values	12
5.3. Manual Shutter Settings at CLK Sync. Mode (FAST Trigger Mode)	12
5.4. Notes for Function Settings	12
6. External Connector Pin Assignment	13
6.1. 12pins Circular Connector HR10-10R-12PA(73) (HIROSE) or equivalent	13
6.2. Camera Link Connector 12226-1100-00PL (SUMITOMO 3M)	14
6.3. PoCL Selection Switch (SW1)	14
7. Timing Chart	15
7.1. Horizontal Sync. Timing (2Tap Configuration mode)	15
7.2. Vertical Sync. Timing (2Tap Configuration mode)	15
7.3. Horizontal Sync. Timing (4Tap Configuration mode)	16
7.4. Vertical Sync. Timing (4Tap Configuration mode)	16
7.5. Horizontal Sync. Timing (8Tap Configuration mode)	17
7.6. Vertical Sync. Timing (8Tap Configuration mode)	17
7.7. Horizontal Sync. Timing (10Tap Configuration mode)	18
7.8. Vertical Sync. Timing (10Tap Configuration mode)	18
7.9. Fixed Trigger Shutter Mode	19
7.10. FAST Fixed Trigger Shutter Mode	20
7.11. Pulse Width Trigger Shutter Mode	21
7.12. FAST Pulse Width Trigger Shutter Mode	22
8. Partial Scan Mode	23
9. Serial Communication Function	25
10. Defective Pixel Correction	26
11. User Data SAVE/Read-out Function	29
11.1. Save User Data	29
11.2. Reading Out of User Data	29
12. Factory Settings	30
13. Sensor Optical Axis Accuracy	31
14. Dimensions	32
15. Case for Indemnity	33

16.	CMOS Pixel Defect	33
17.	Product Support	33
18.	Ordering Information	33
19.	Licensing	33

Aegis Electronic Group
www.aegiselect.com

1. Handling Precautions

The camera must not be used for any nuclear equipment or aerospace equipment with which mechanical failure or malfunction could result in serious bodily injury or loss of human life. Our warranty does not apply to damages or defects caused by irregular and/or abnormal use of the product.

Please observe all warnings and cautions stated below.

Our warranty does not apply to damages or malfunctions caused by neglecting these precautions.

- Do not use or store the camera in the extremely dusty or humid places.
- Do not apply excessive force or static electricity that could damage the camera. Handle the camera with care.
- Do not shoot direct images that are extremely bright (e.g., light source, sun, etc.), and when camera is not in use, put the lens cap on.
- Follow the instructions in [Chapter 6, "External Connector Pin Assignment"](#) for connecting the camera. Improper connection may cause damages not only to the camera but also to the connected devices.
- Confirm the mutual ground potential carefully before connecting the camera to monitors or computers. Any AC leaks from the connected devices may cause damages or destroy the camera.
- Do not apply excessive voltage. (Use only the specified voltage.) Unstable or improper power supply voltage may cause damages or malfunction of the camera.
- The voltage ripple of camera power DC +12V±10% shall be within ±50mV. Improper power supply voltage may cause noises on the video signals.
- The rising time of camera power supply voltage shall be less than +10V, Max 60ms. Please avoid noises like chattering when rising.

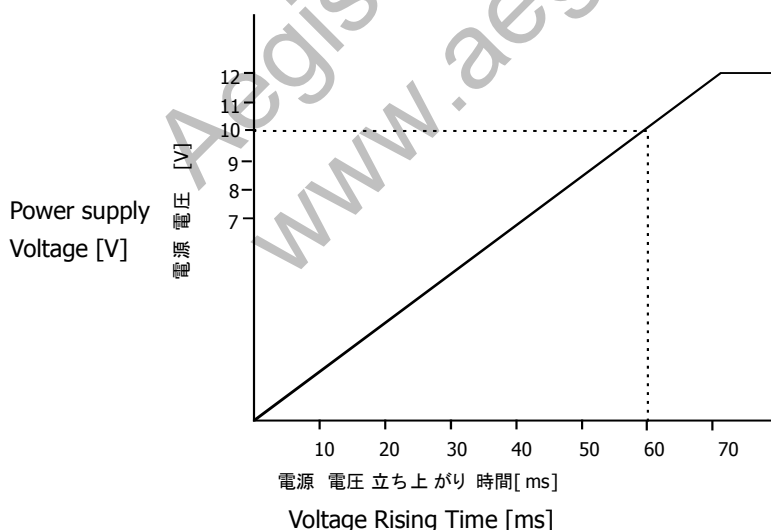

[About Heat Dissipation]

CIS basically recommends you to use M42 mount or F mount lenses with VCC-12CL4R camera.

Lens mount conversion rings are prepared.

Using 4pcs of M4 screws at the front and fixing the camera on a metal frame also helps to dissipate heat effectively.

2. Product Outline

VCC-12CL4R is a Camera Link interfaced and 12M resolution color camera module. 12.29M pixels, 1.1 type (diagonal length 17.6mm) color CMOS sensor is utilized. Entire pixels can be read out at 1/53s with FULL Configuration output.

Features

- Global shutter CMOS sensor
- Camera Link Base, Medium, FULL, 8tap10bit, 10tap8bit are supported
- Fixed trigger shutter mode, Pulse width trigger shutter mode
- Full frame rate and video output are as below.

2Tap Base Configuration	13.324fps	8bit/10bit
4Tap Medium Configuration	26.647fps	8bit/10bit
8Tap FULL Configuration	53.294fps	8bit
8Tap10bit Configuration	53.294fps	10bit
10Tap8bit Configuration	62.984fps	8bit
Factory Setting: 4Tap8bit Configuration		

3. System Configuration

3.1. Camera

- Camera, VCC-12CL4R

3.2. Optional Accessories

- M42-F Lens Mount Conversion Ring

3.3. Free Software

- CIS control panel software for evaluation purpose only is downloadable via our web.
CIS shall be exempted from taking responsibility and held harmless for damage or malfunction of your hardware and software caused by using this control software. The purpose of this control software prepared is for user to check operation and evaluate our products. Please be noted that CIS does not customize the program nor provide source code.

3.4. Packaging

- Individual Carton
- Master Carton (20pcs/carton)

Note) Master carton may vary depends on the quantity to be shipped.

4. Specifications

4.1. General Specifications

(1) Pickup Device	Device type	Diagonal length 17.6mm (1.1 type) Global shutter color CMOS			
	Effective pixel number	4096(H) × 3000(V)			
	Unit cell size	3.45μm(H) × 3.45μm(V)			
(2) Video Output Frequency	Pixel clock	84.86MHz			
	2tap Configuration mode:	Horizontal Frequency	40.947KHz	Horizontal Clock	2080CLK
		Vertical Frequency	13.324Hz	Scanning Lines	3062H
	4tap Configuration mode:	Horizontal Frequency	81.593KHz	Horizontal Clock	1040CLK
		Vertical Frequency	26.647Hz	Scanning Lines	3062H
	8tap Configuration mode:	Horizontal Frequency	163.19KHz	Horizontal Clock	520CLK
		Vertical Frequency	53.294Hz	Scanning Lines	3062H
	10tap Configuration mode:	Horizontal Frequency	192.86KHz	Horizontal Clock	440CLK
		Vertical Frequency	62.984Hz	Scanning Lines	3062H
(3) Sync. System	Internal sync. system				
(4) Video Output	2Tap Base Configuration				
	4Tap Medium Configuration				
	8Tap Full Configuration				
	8Tap10bit Configuration				
	10Tap8bit Configuration				
(5) Output Format	Sensor AD	10bit			
	Camera Link output	8bit/10bit RAW output			
(6) Sensitivity	F5.6 2000lx (Shutter speed 1/27s(OFF), Gain 0dB, 4tap8bit Configuration mode)				
(7) Minimum Illumination	F1.4 2.3 lx (Shutter speed 1/27s(OFF), Gain +36dB, 4tap8bit Configuration mode)				
(8) Power Requirements	DC+12V±10% 12 pins circular connector or PoCL				
(9) Power Consumption	3.6 W (DC+12V IN, 4Tap 8bit Configuration mode, Full frame scan output)				
	4.0 W (DC+12V IN, 10Tap 8bit Configuration mode, Full frame scan output)				
(10) Dimensions	Please refer to the overall dimension drawings. (H:55mm W:55mm D:25mm excluding projection)				
(11) Weight	Approx. 100g				
(12) Lens Mount	M42 mount ※Please refer to the overall dimension drawings.				
(13) Optical Axis Accuracy	Please refer to the drawings of CMOS Optical Axis Accuracy.				
(14) Gain Variable Range	0dB ~ +36dB (Guaranteed range)				
(15) White Balance Adjustable Range	2800K ~ 9000K				
(16) Shutter Speed Variable Range	OFF ~ Approx. 1/51,000s (At 10tap mode)				
(17) Trigger Mode	Fixed shutter trigger mode, Pulse width shutter trigger mode				
(18) Partial Scan	Full frame scan ~ 4 line (4 lines/step)				
(19) Safety/Quality Standards	UL: Conform to UL Standard including materials and others.				
	CE				
	EMC	2014/30/EU			
		Emission	: EN61000-6-4:2007+A1:2011		
		Immunity	: EN61000-6-2:2005		
	RoHS	2011/65/EU			
	Conformity Standards	EN50581 (RoHS 2)			
	KC	R-R-cIs-VCC-12CL4M			
(20) Durability	Vibration	Acceleration	: 98m/s ² (10G)		
		Frequency	: 20~200 Hz		
		Direction	: X,Y,Z 3 directions		
		Testing time	: 120 min for each directions		
	Shock	No malfunction shall be occurred with 980m/s ² (100G) for ±X,±Y, and ±Z, 6 directions.			
(21) Operational Environment	Operation guaranteed temperature	- 5 ~ +45°C	Humidity	20 ~ 80%RH With no condensation.	
(22) Storage Environment	-25 ~ +60°C Humidity 20 ~ 80%RH With no condensation.				

4.2. Input and Output Signals Specifications

(1)Video Output Data	Effective video output	4096(H) × 3000(V)	At Full frame scan
(2)Sync. Signal Output	LVAL :No. 6 pin	12pins circular connector (TTL output)	
	FVAL :No. 7 pin		
	EXPOSURE :No. 9 pin		
	DVAL :No. 10pin		
	LVAL :No. 11pin		
	FVAL	Camera Link output (LVDS)	
	DVAL		
	SP(EXPOSURE)		
(3)Trigger Input	Polarity	Positive/Negative Switchable	Selectable
	Pulse width	1H(Min.) ~ Approx. 2 frame	
		Functionally, no upper limitation is set but at long time exposure, dark noises and shading noises might be noticeable.	
	Trigger input :No. 11 pin	12 pins circular connector (TTL)	
	:CC1	Camera Link input (LVDS)	
(5)Serial Communications	SerTC (Serial to Camera)	Camera Link input (LVDS)	
	SerTFG (Serial to Frame Grabber)	Camera Link output (LVDS)	
Video Signals	White clip level	At digital 10bit	: 3FFh
	Setup level	At digital 10bit	: 8±3h
	Dark shading	At digital 10bit	: Both horizontal and vertical should be under 00Fh. (Condition: Gain 0dB)

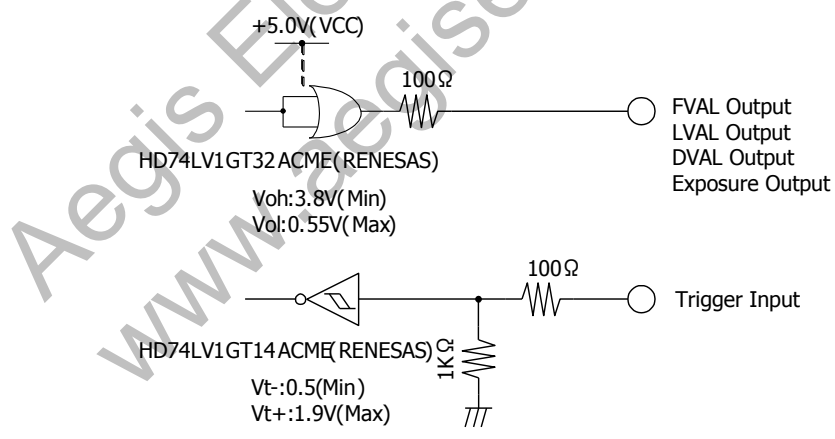

IO Interface of 12pins Circular connector at rear

4.3. CMOS Spectral Response ※The lens characteristics and illuminant characteristics are excluded.

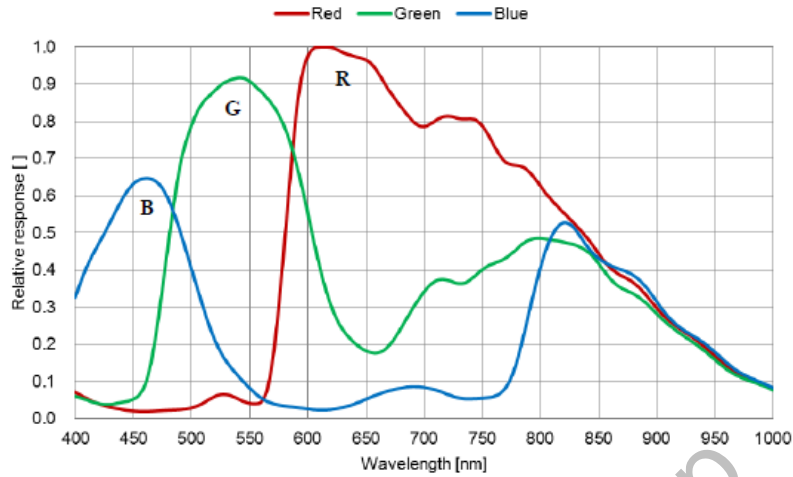

4.4 Video Output Format

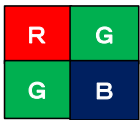

Bayer Pattern : RGGB

※ Please note that Bayer Pattern shall also flip when the output image is set to vertical flip and horizontal flip.

(1) 2tap Base Configuration mode : 13.324fps

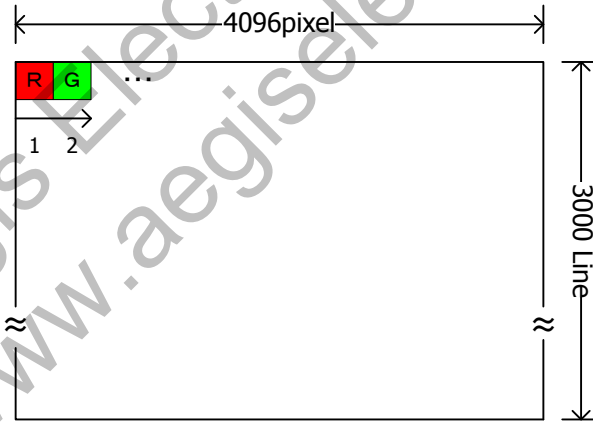

(2) 4tap Medium Configuration mode : 26.674fps

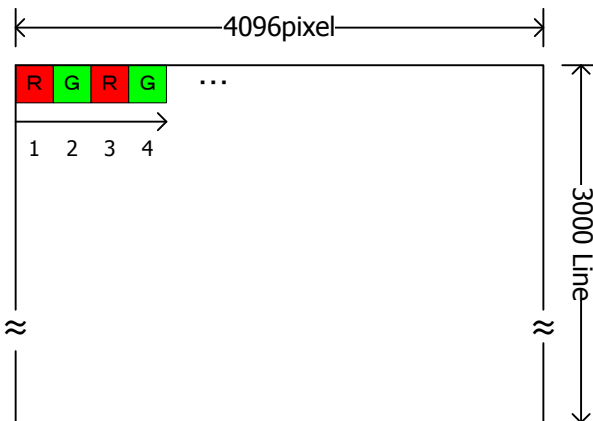

(3) 8tap Full, 8tap10bit Configuration mode : 53.294fps

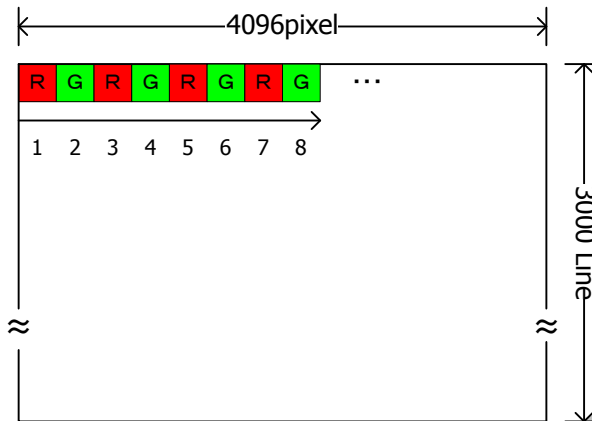

(4) 10tap8bit Configuration mode : 62.984 fps

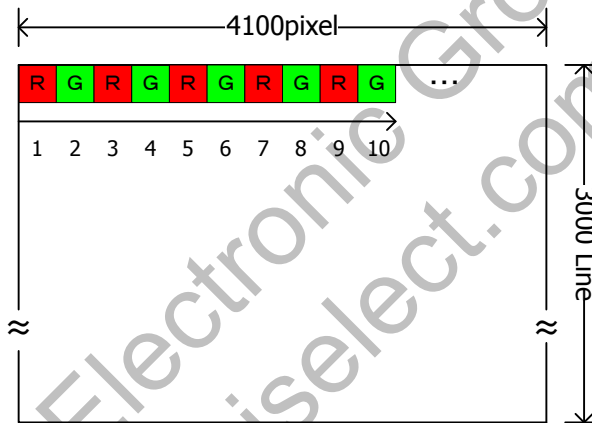

Aegis Electronic Group
www.aegiselect.com

5. Camera Function Settings

Camera functions can be set with serial communications.

Function	Address	Data	Description
Camera Mode	1	0	2Tap 8bit/10bit
		1	4Tap 8bit/10bit
		2	8Tap 8bit/10bit
		3	10Tap 8bit
Output Data Selection	2	0	8bit output
		1	10bit output (Invalid at 10Tap mode)
Trigger Shutter Mode ※FAST trigger mode is forced to be disabled at normal shutter mode. To enable FAST trigger mode, fixed trigger shutter mode or pulse width trigger shutter model shall be selected.	3	0	Normal shutter mode (Free-run) (Shutter speed can be set with address 23 and 24).
		1	Fixed trigger shutter mode (Shutter speed can be set with address 23 and 24)
		2	Pulse width trigger shutter mode (Shutter speed can be set with trigger pulse width).
Trigger Polarity	4	0	Positive
		1	Negative
Trigger Input	5	0	Camera Link CC1
		1	12pins circular connector No.11 pin (TTL)
FAST trigger mode selection ※Trigger mode to capture the trigger input with H cycle or the mode to capture the trigger input with CLK sync is switchable. However, please be noted that overlapped operation cannot be operative at CLK sync mode. This mode is effective to avoid hunting at high speed shutter operation.	6	0	H sync. mode (Trigger is taken with H sync.) ※A trigger during outputting images can be input (Overlap operation is doable). ※Exposure time during normal shutter mode and fixed trigger shutter mode can be set per H.
		1	FAST trigger mode (Trigger is taken with CLK sync.) ※A trigger during outputting images cannot be input (Overlap operation is not doable). ※Exposure time of manual shutter during fixed trigger shutter mode is changed to be set per μ s (approximate value).
Test Pattern	7	0	OFF
		1	Color bar (Output is valid only when the cursor is OFF.)
		2	Color bar (Gradation) (Output is valid only when the cursor is OFF.)
Cursor Display	8	0	OFF
		1	ON (Cursor output has its priority when test pattern output is ON.)
Cursor X Coordinate	9	0 ~ 4095	Horizontal 4096 pixels (Factory setting is 0. When operating coordinate, it is reset to (0, 0).)
Cursor Y Coordinate	10	0 ~ 2999	Vertical 3000 line (Factory setting is 0. When operating coordinate, it is reset to (0, 0).)
Output Image Horizontal Flip When in operation, the cursor is reset to (0, 0).	11	0	Normal
		1	Horizontal flip
Output Image Vertical Flip When in operation, the cursor is reset to (0, 0).	12	0	Normal
		1	Vertical flip

Defective Pixel Correction	13	0	OFF
		1	ON
Serial Communications Baud Rate Selection ※INIT command is excluded.	14	0	9,600baud
		1	115,200baud
Black Level Adjustment	16	0 ~ 15	Adjustment of black level (To return to factory settings, please execute INIT command.)
Gain	20	0	0dB fixed gain
		1	+ 6dB fixed gain
		2	+12dB fixed gain
		3	+18dB fixed gain
		4	+24dB fixed gain
		5	+30dB fixed gain
		6	+36dB fixed gain
		11	Manual gain (Please refer to the address 21.)
Manual Gain	21	0 ~ 480	0~ + 48dB (1dig=0.1dB)
Shutter	23	0 ~ 15	Preset shutter (Please refer to the List of Preset Shutter)
		16	Manual shutter (Please refer to the address 24)
Manual Shutter	24	1 ~ 3000	1line/step (Please refer to Formula to Calculate Manual Shutter Values)
Manual Shutter (At FAST trigger)		15 ~ 200,000	Specify the exposure time with μ s (approximate value). Please refer to the manual shutter settings of FAST trigger mode (CLK sync mode)
White Balance	30	0	Through
		1	White balance preset register 1 (Please refer to the address 31 and 33)
		2	White balance preset register 2 (Please refer to the address 31 and 33)
		3	White balance preset register 3 (Please refer to the address 31 and 33)
Manual White Balance R	31	0 ~ 800	Unit [%] The saturation level of R shall fall at the setting under 100.
Manual White Balance B	33	0 ~ 800	Unit [%] The saturation level of B shall fall at the setting under 100.
One Push White Balance Trigger	34	1,2,3	Write Only. When executed, it specifies the register where to save the preset. (=White balance preset register 1, 2, and 3). The set values at that time shall be reflected to the address 31, 33, and the selected white balance preset register. Execute this with shooting a single object for the photometrical purpose of entire screen.
Vertical Partial (Lump Settings)	50	3 parameters	The 1 st parameter: Partial number (0~7) The 2 nd parameter: Start line (0~2996 per 4 lines) The 3 rd parameter: Effective line numbers (4~3000 per 4 lines)
		1 parameter at acquisition	Specify the partial numbers (0~7).

Vertical Partial Mode	54	0	OFF
When in operation, the cursor is reset to (0, 0).		1	Reflect the value set by the address 50, then set vertical partial ON.
Factory Settings	INIT	None	Restore the settings to the factory settings.
Data Save	SAVE	None	Save the camera settings.
White Defect Detection by Users	100	2 parameters	Detect the later occurred white defects and register them.
Addition of Defect Pixels by Users	101	2 parameters	Register the defective pixels specified with (x, y).
Deletion of Defect Pixels by Users	102	2 parameters	Delete the defective pixels specified with (x, y).
Complete Deletion of Defect Pixels by Users	103	1 (fixed)	Delete all the defect pixels detected and registered by the user.
Indication of Defect Pixels	104	0 at set up	Turn OFF the indication of bright point
		1 at set up	Indicate the position of the correcting pixel with lighting.
		1 at set up	Indicate the list of data at ex-factory and the registered data by the user.
		2 at set up	Indicate only the list of the registered data by the user.
		3 at set up	Indicate the registered number of the defect pixels per reed.
		4 at set up	Line up and indicate the registered number of the defect pixels per reed.
		User Data Settings	200

※ Do not set any address or data other than specified the above.

5.1. The List of Preset Shutter

4096dot X 3000line				
Data	2Tap mode	4Tap mode	8Tap mode	10Tap mode
0	1/14(OFF)	1/27(OFF)	1/54(OFF)	1/64(OFF)
1	1/60	1/60	1/60	↑
2	1/100	1/100	1/100	1/100
3	1/150	1/150	1/150	1/150
4	1/200	1/200	1/200	1/200
5	1/250	1/250	1/250	1/250
6	1/500	1/500	1/500	1/500
7	1/1000	1/1000	1/1000	1/1000
8	1/2000	1/2000	1/2000	1/2000
9	1/2500	1/2500	1/2500	1/2500
10	1/5000	1/5000	1/5000	1/5000
11	1/10000	1/10000	1/10000	1/10000
12	1/16000	1/20000	1/20000	1/20000
13	1/26000	1/26000	1/30000	1/29000
14	↑	1/38000	1/38000	1/40000
15	↑	↑	1/49000	1/51000

5.2. Formula to Calculate Manual Shutter Values

Formula : Exposure Time = Time for 1 line (Please refer to the chart below) × Address 24 set value + **14.26μs**

Camera Mode	Time for 1 line
2Tap Configuration mode	24.512μs
4Tap Configuration mode	12.256μs
8Tap Configuration mode	6.128μs
10tap Configuration mode	5.185μs

※ The minimum setting value shall be 1 and the maximum setting value shall be clipped with 3000 or the total line number for partial settings.

5.3. Manual Shutter Settings at CLK Sync. Mode (FAST Trigger Mode)

- The minimum setting value: **15μs** (approximate value)
- The maximum setting value: **200ms** (approximate value)
 - ※ At long exposure settings, bright spot may be noticeable.
- Setting unit: Per 1μs (approximate value)
 - ※ Slight differences may occur since it is generated by **74.25MHz** clock.

5.4. Notes for Function Settings

- ※ 2 seconds shall be waited after power is turned on for the camera to operate properly.
- ※ We don't have an assumption that vertical image flip, horizontal image flip, partial settings, and one push auto white balance trigger commands shall be reflected immediately. Please note that a dummy trigger is needed at trigger mode.
- ※ When camera mode (Tap mode) is changed, please re-set other functions, too.
- ※ When gain is set to over +36dB, image quality deterioration is inevitable. Please evaluate first.

6. External Connector Pin Assignment

6.1. 12pins Circular Connector HR10-10R-12PA(73) (HIROSE) or equivalent

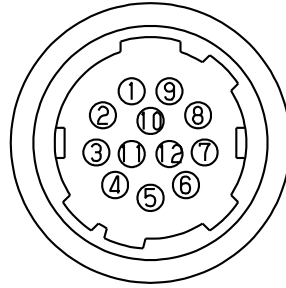

Pin No.	Description
1	GND
2	Power input (DC+12V)
3	GND
4	NC
5	GND
6	LVAL output
7	FVAL output
8	GND
9	Exposure output
10	DVAL output
11	TRIGGER input
12	GND

6.2. Camera Link Connector 12226-1100-00PL (SUMITOMO 3M)

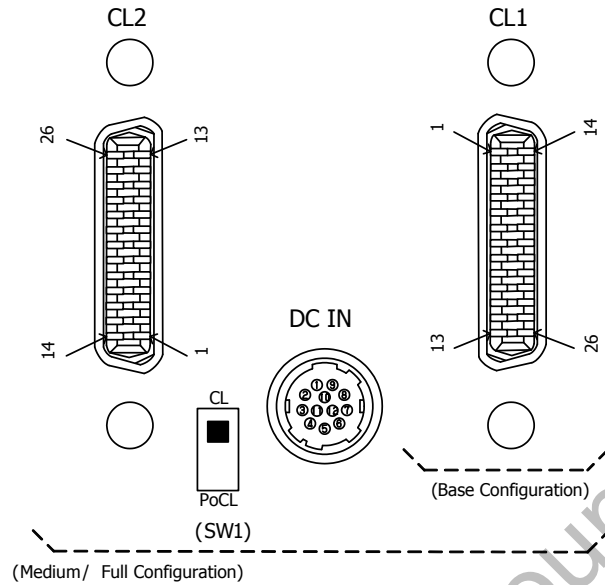

Connector (CL2)

Pin No.	Description	Pin No.	Description
1	NC/ +12V(PoCL)	14	GND
2	Y0-	15	Y0+
3	Y1-	16	Y1+
4	Y2-	17	Y2+
5	Yclk-	18	Yclk+
6	Y3-	19	Y3+
7	100Ω	20	Terminated
8	Z0-	21	Z0+
9	Z1-	22	Z1+
10	Z2-	23	Z2+
11	Zclk-	24	Zclk+
12	Z3-	25	Z3+
13	GND	26	NC/ +12V(PoCL)

Connector (CL1)

Pin No.	Description	Pin No.	Description
1	NC/ +12V(PoCL)	14	GND
2	X0-	15	X0+
3	X1-	16	X1+
4	X2-	17	X2+
5	Xclk-	18	Xclk+
6	X3-	19	X3+
7	SerTC+	20	SerTC-
8	SerTFG-	21	SerTFG+
9	CC1- (Trigger IN -)	22	CC1+ (Trigger IN +)
10	CC2+	23	CC2-
11	CC3-	24	CC3+
12	CC4+	25	CC4-
13	GND	26	NC/ +12V(PoCL)

6.3. PoCL Selection Switch (SW1)

- (1) PoCL...To be selected when a PoCL frame grabber board is used and power is fed via the frame grabber board.
- (2) CL... To be selected when Non-PoCL frame grabber board is used. Power shall be fed via 12pins circular connector.

※ Please make sure that power is OFF when changing the switch settings. If the switch setting was changed while the power is ON, it may cause malfunction or damages to the camera.

※ There is a mode that exceed the power consumption standard value (4.0W) of PoCL (×1 cable) power feeding. We recommend to feed the power via both CL1 and CL2 at PoCL, or use 12pins circular connector.

7. Timing Chart

7.1. Horizontal Sync. Timing (2Tap Configuration mode)

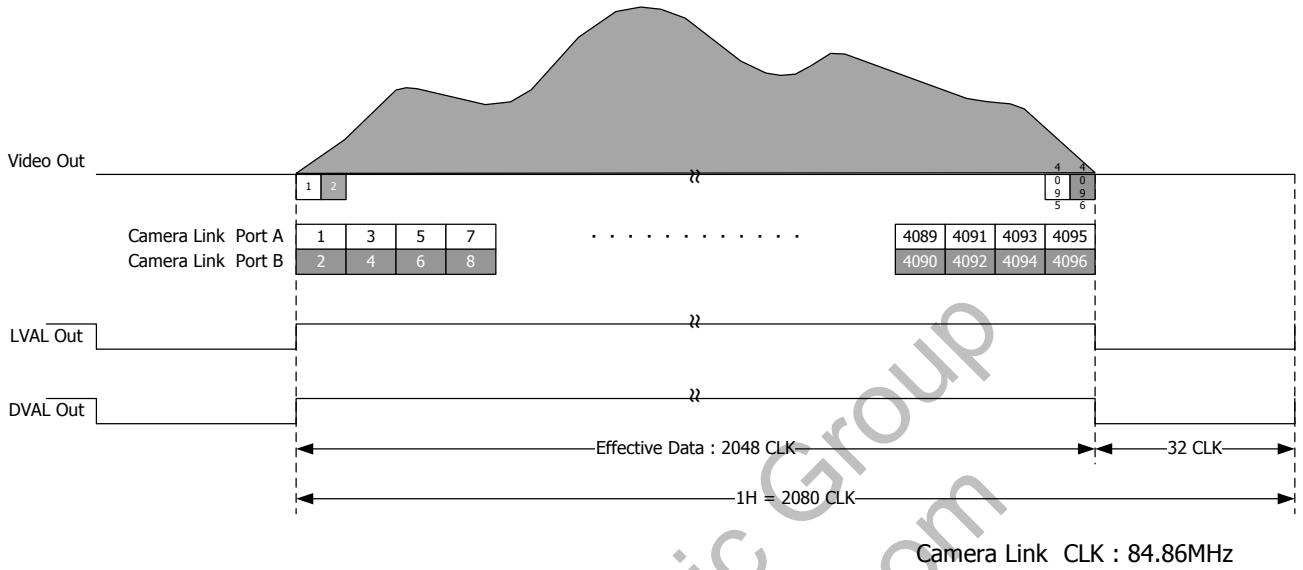

7.2. Vertical Sync. Timing (2Tap Configuration mode)

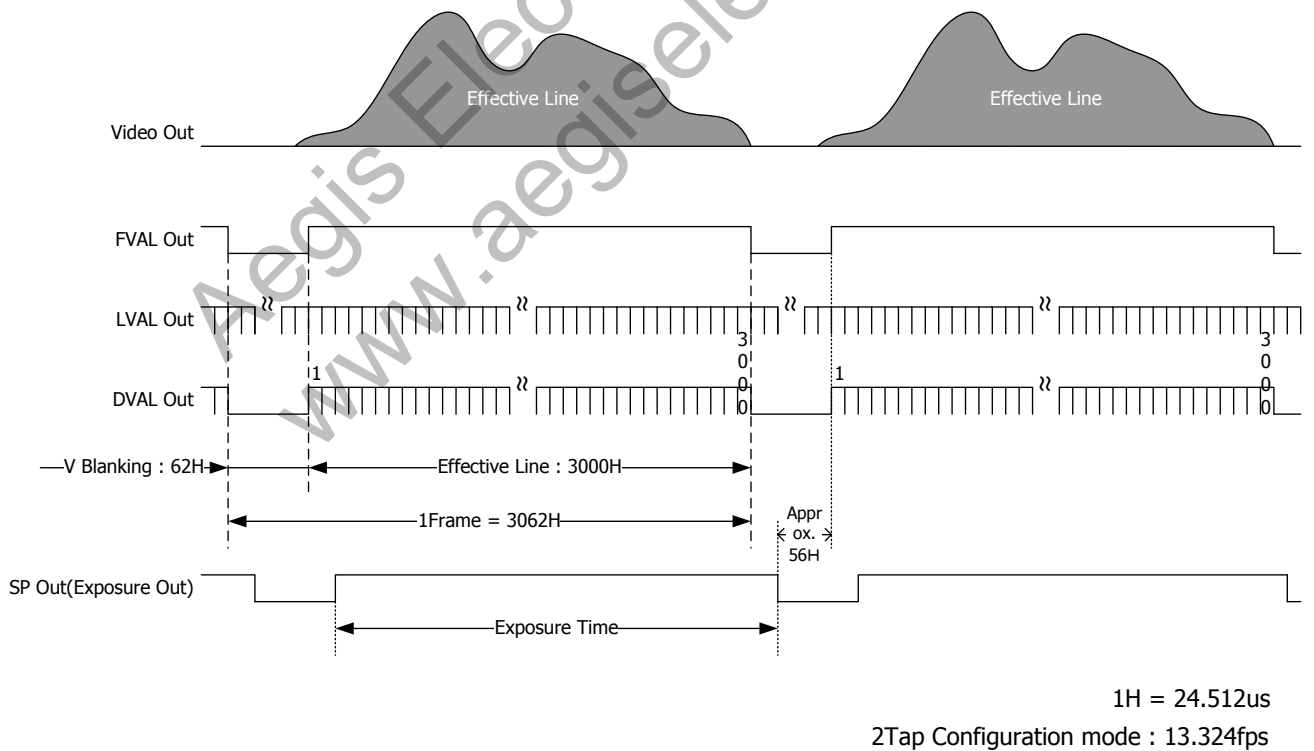

7.3. Horizontal Sync. Timing (4Tap Configuration mode)

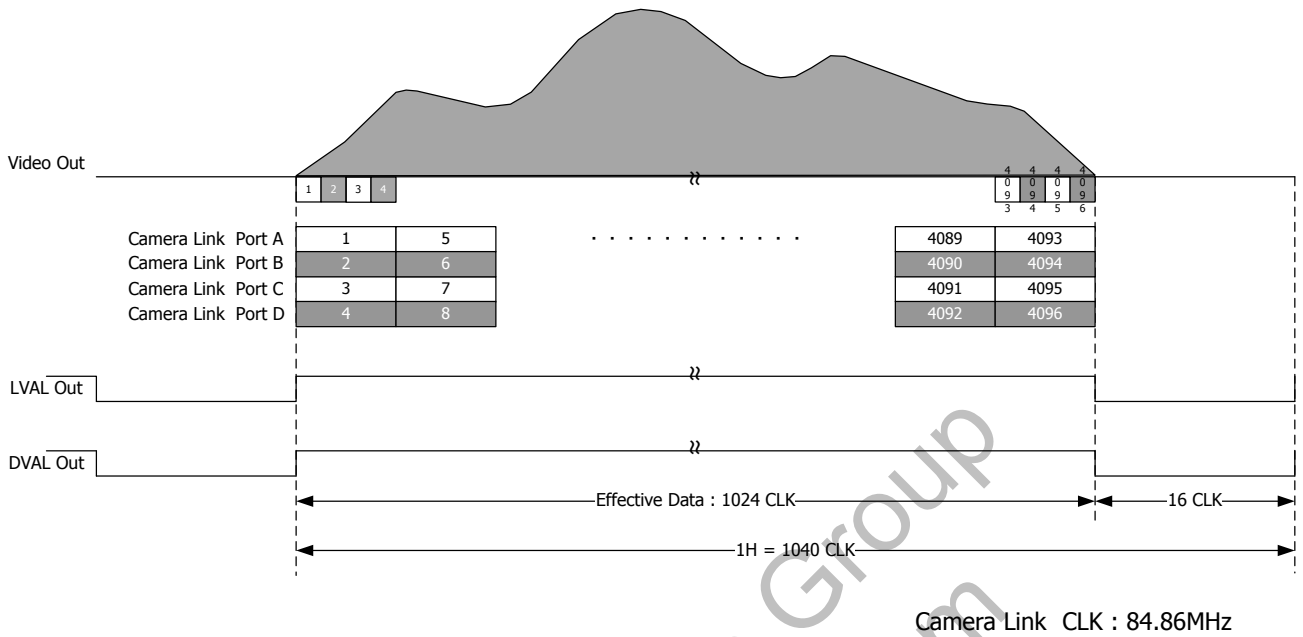

7.4. Vertical Sync. Timing (4Tap Configuration mode)

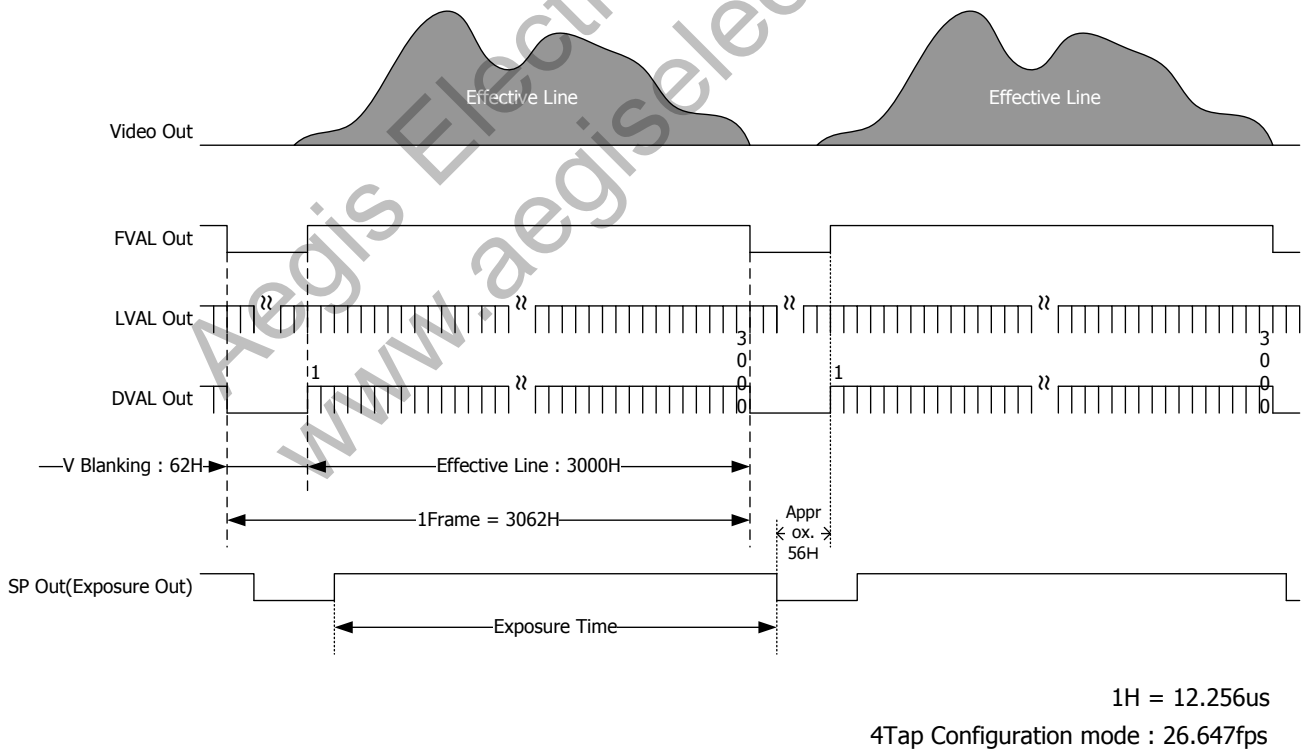

7.5. Horizontal Sync. Timing (8Tap Configuration mode)

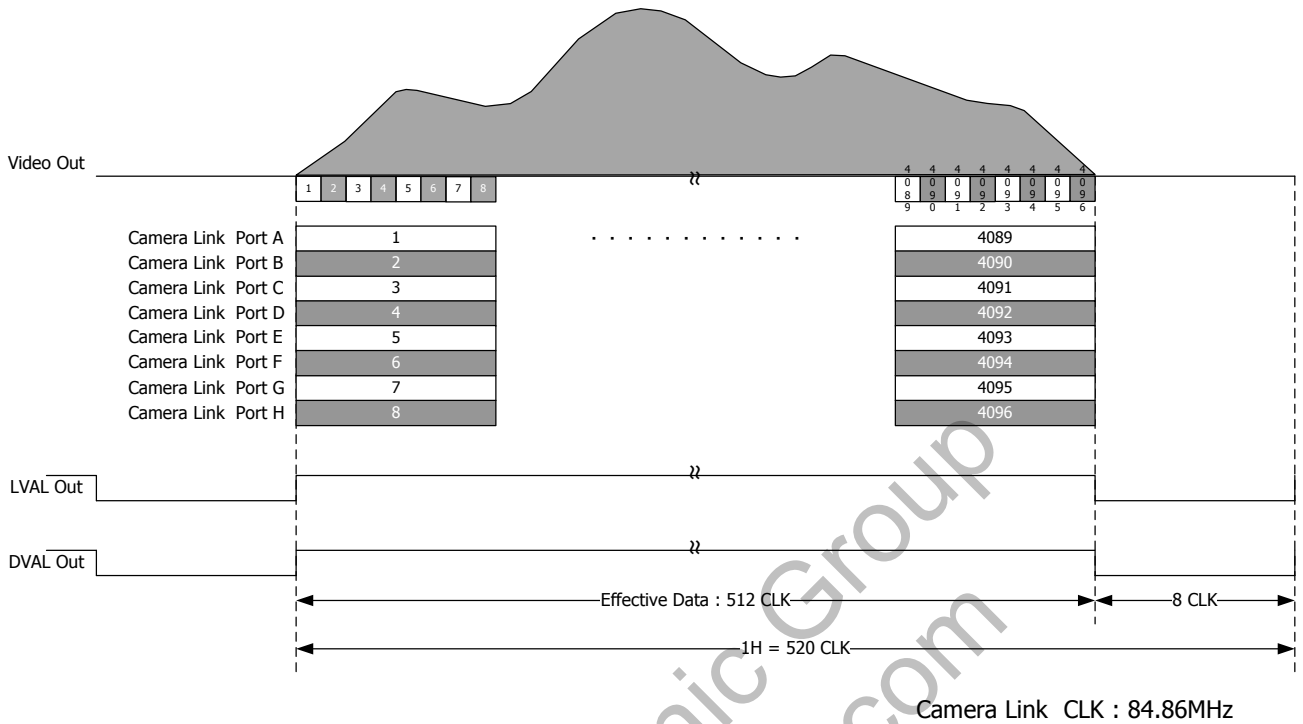

7.6. Vertical Sync. Timing (8Tap Configuration mode)

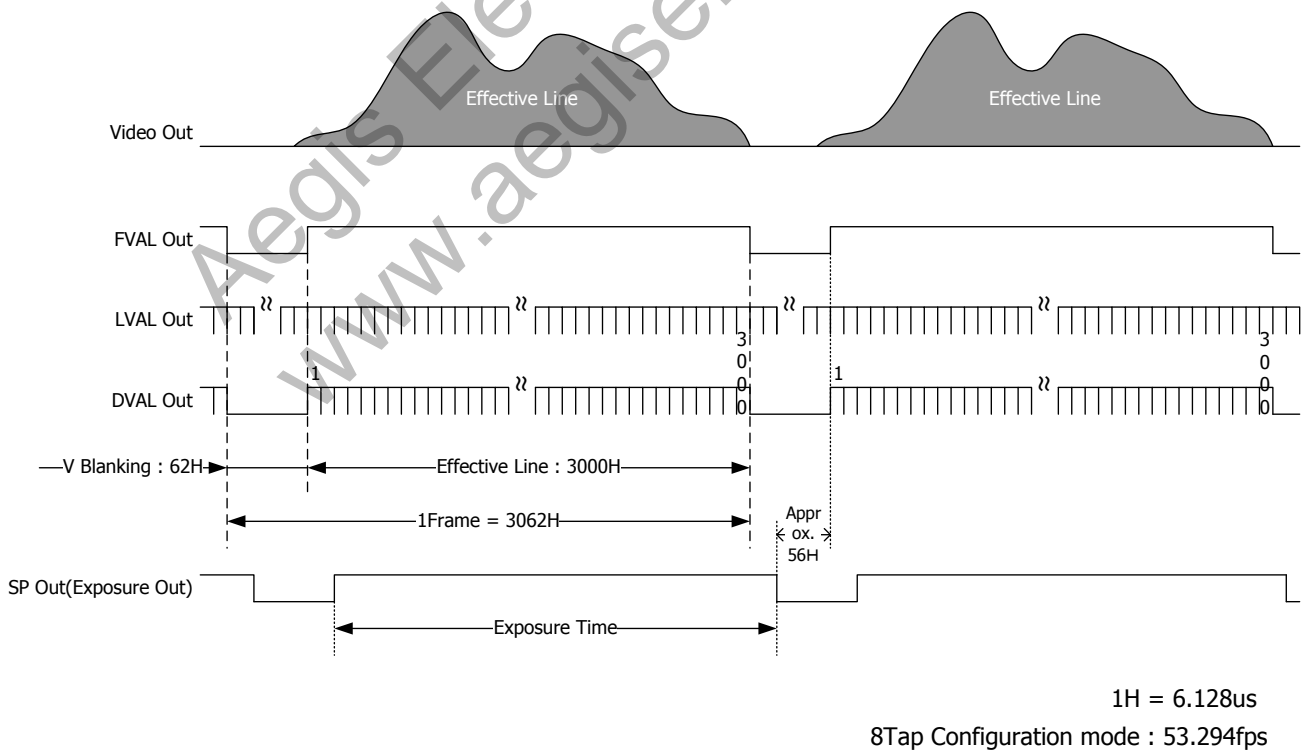

7.7. Horizontal Sync. Timing (10Tap Configuration mode)

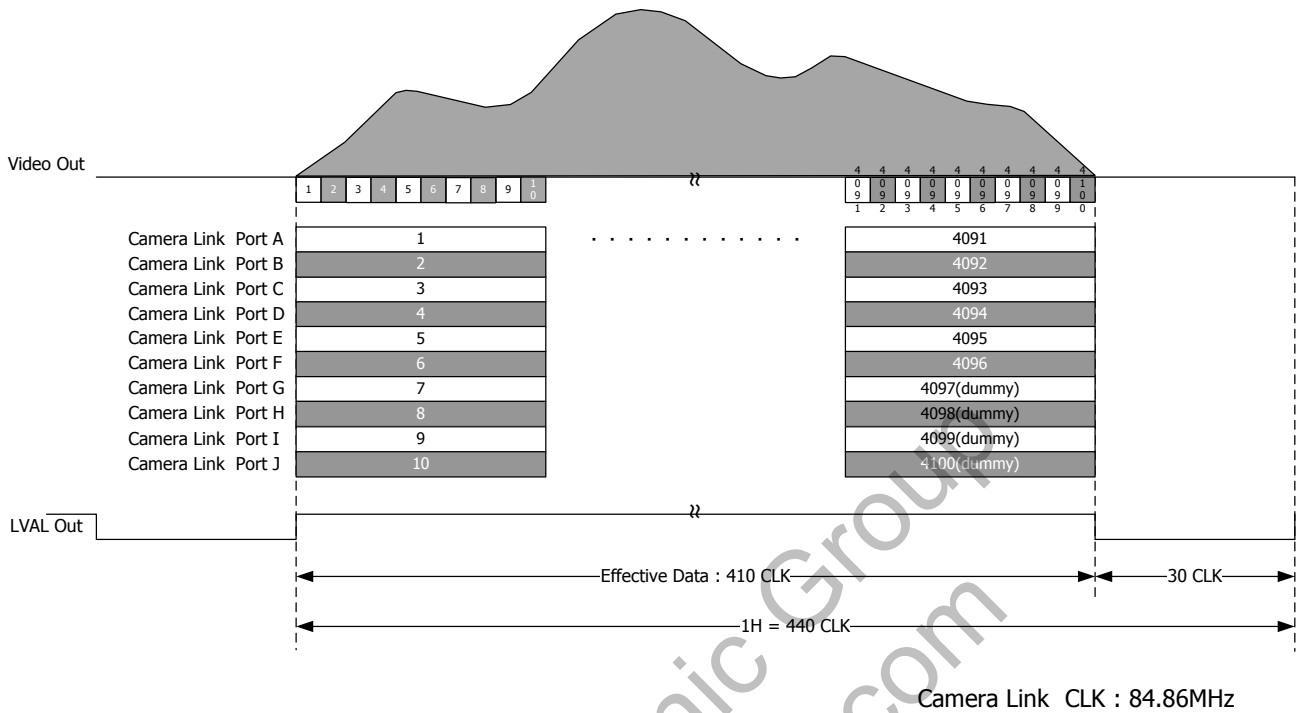

7.8. Vertical Sync. Timing (10Tap Configuration mode)

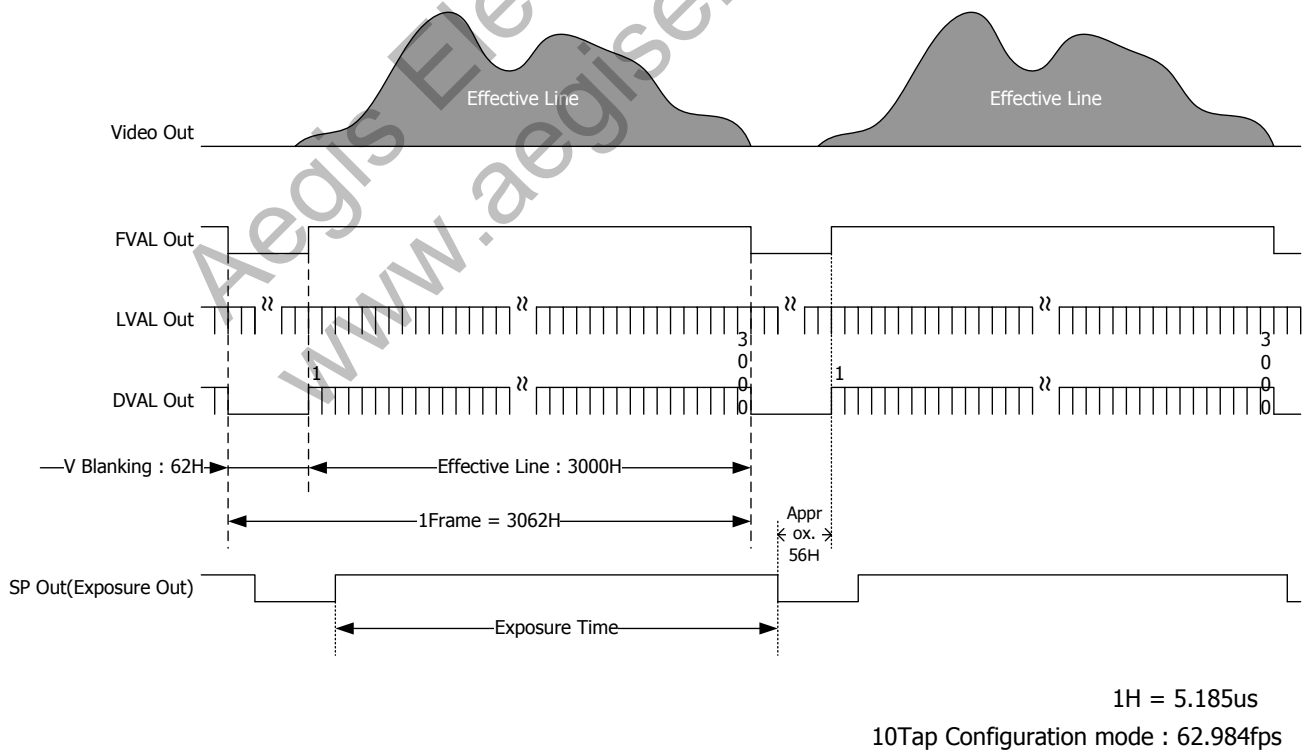

7.9. Fixed Trigger Shutter Mode

- This is the mode to start exposure with external input trigger signals, and set the exposure time with serial Commands.
 - Trigger operation is H Sync., and V-sync. Reset system. The delay time (Exposure Time Delay) from detecting trigger edge in the camera to actually starting exposure is 2H ~ 3H.
- Since the external trigger signals synchronize with camera internal H signals, 1H jitter occurs to Exposure Time Delay. The trigger pulse with the minimum 1H and more shall be input (Please refer to the table below for the details of 1 line width).

Camera Mode	Time for 1 line
2Tap Configuration mode	24.512μs
4Tap Configuration mode	12.256μs
8Tap Configuration mode	6.128μs
10Tap Configuration mode	5.185μs

- There is an exposure time period for approx. **14.26μs** at the edge right after the exposure output.



- Triggers can be accepted while outputting images. However, please note that the trigger signal to start the next video outputting should not be input before the completion of outputting the prior images.
 - Trigger input during the exposure time shall be ignored in the camera. (Please refer to (A) in the drawing below.)
- Please note that the trigger shorter than 1 frame cycle shall not be used.

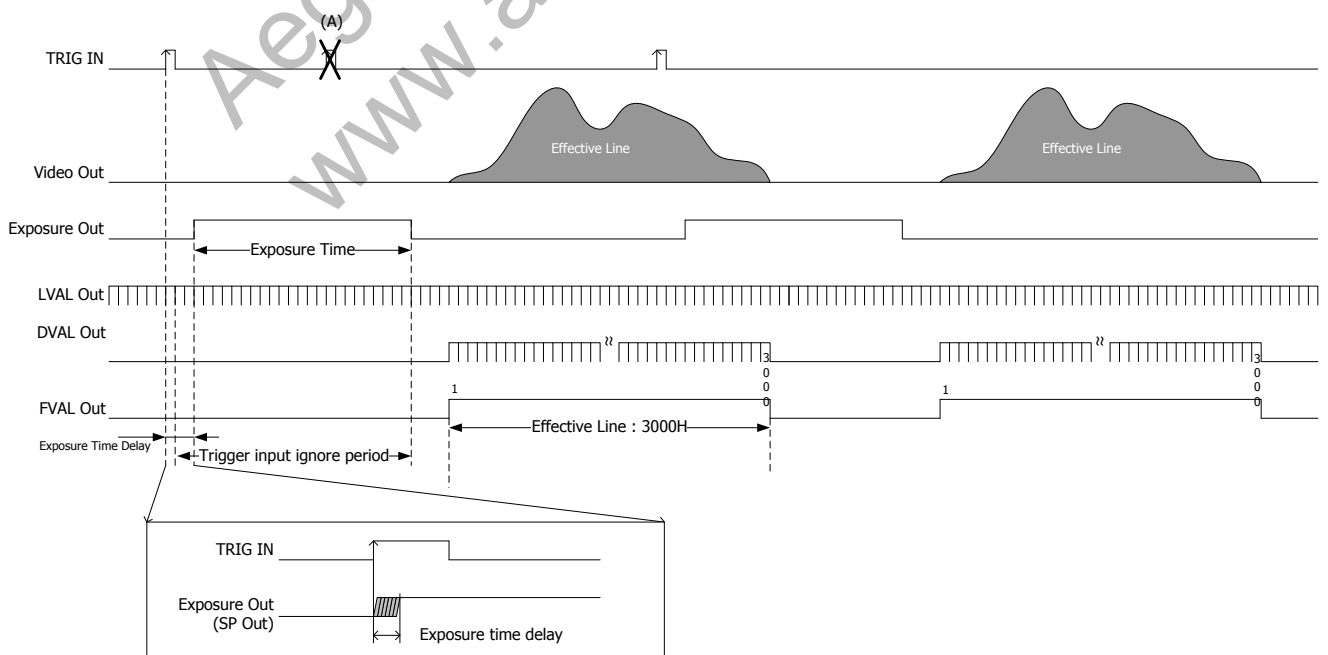

7.10. FAST Fixed Trigger Shutter Mode

- This is the mode to start exposure with external input trigger signals, and set the exposure time with serial commands.
- Trigger operation is CLK sync. and V-sync. reset system.

The delay time (Exposure Time Delay) from detecting trigger edge in the camera to actually starting exposure is approx. 0.05 μ s. Input more than 1 μ s width pulse as a trigger.

- There is an exposure time period for approx. **14.26 μ s** at the edge right after exposure output.



- Trigger input while outputting images cannot be accepted.

Trigger input during exposure time or readout time shall be ignored in the camera. (Please refer to (A) and (B) in the drawing below.)

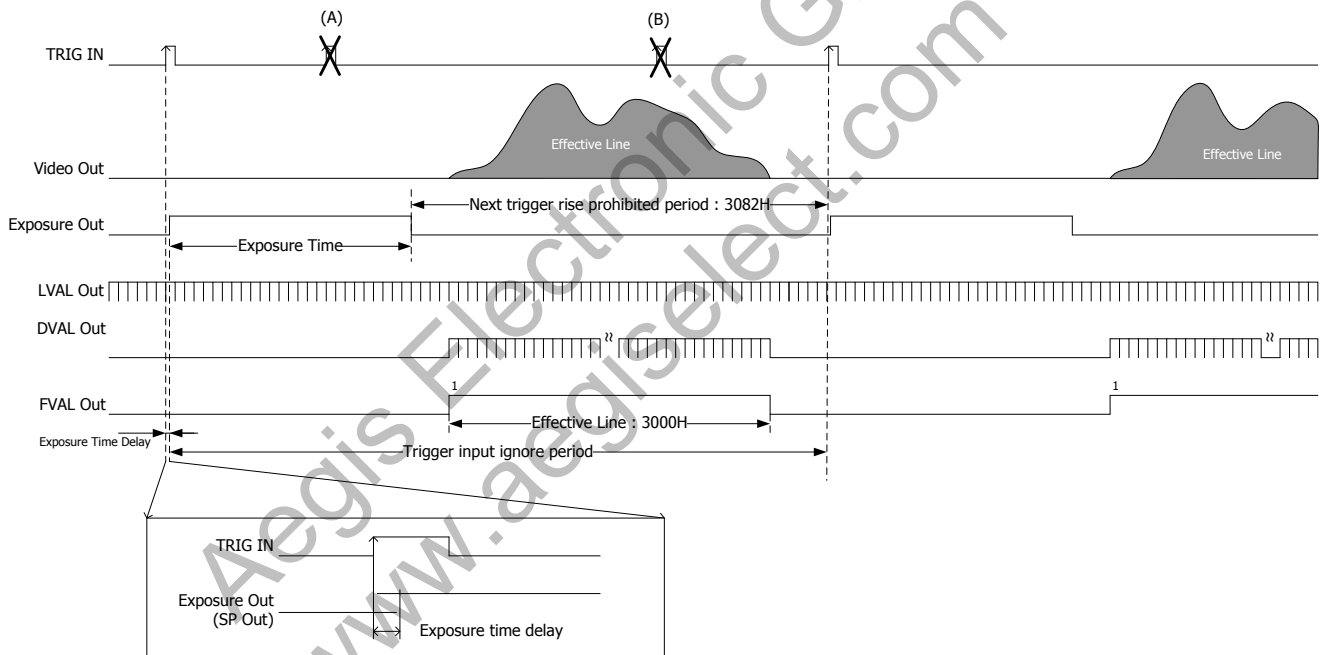

7.11. Pulse Width Trigger Shutter Mode

- This is the mode to start exposure with external input trigger signals, and set the exposure time with pulse width of the trigger signals.
- Trigger operation is H Cycle, and V-sync. reset system.
The delay time (Exposure Time Delay①) from detecting trigger edge in the camera to actually starting exposure is 2H ~ 3H. The delay time (Exposure Time Delay②) from detecting trigger edge in the camera to end exposure is **2H+14.26μs ~ 3H+14.26μs**.
- Since the external trigger signals synchronize with camera internal H cycle, approx. 1H jitter occurs to Exposure Time Delay ① and ②. In case of pulse width trigger mode, jitters may occur at both start and end edges of exposure. At this time, exposure time would change so that flicker might be noticeable in the image, especially when high speed shutter is set. This flicker sometimes can be eliminated when fixed trigger shutter mode is used. However, this problem can be solved by inputting a trigger pulse with synchronizing it to the camera internal H cycle (LVAL).
- Pulse width is min. 1H to approx. 2 frames.
Functionally, there is no upper limitation, but noises such as dark noise shadings may be noticeable at long time exposure.
- There is an exposure time period for approx. **14.26μs** at the edge right after exposure output.



- Trigger input during exposure time shall be ignored in the camera. However, please do not use a trigger shorter than 1 frame cycle.
- Triggers can be accepted while outputting images. However, please note that a trigger signal to start the next video output should not be input before completion of outputting the prior images. (Please refer to (A) in the drawing below).

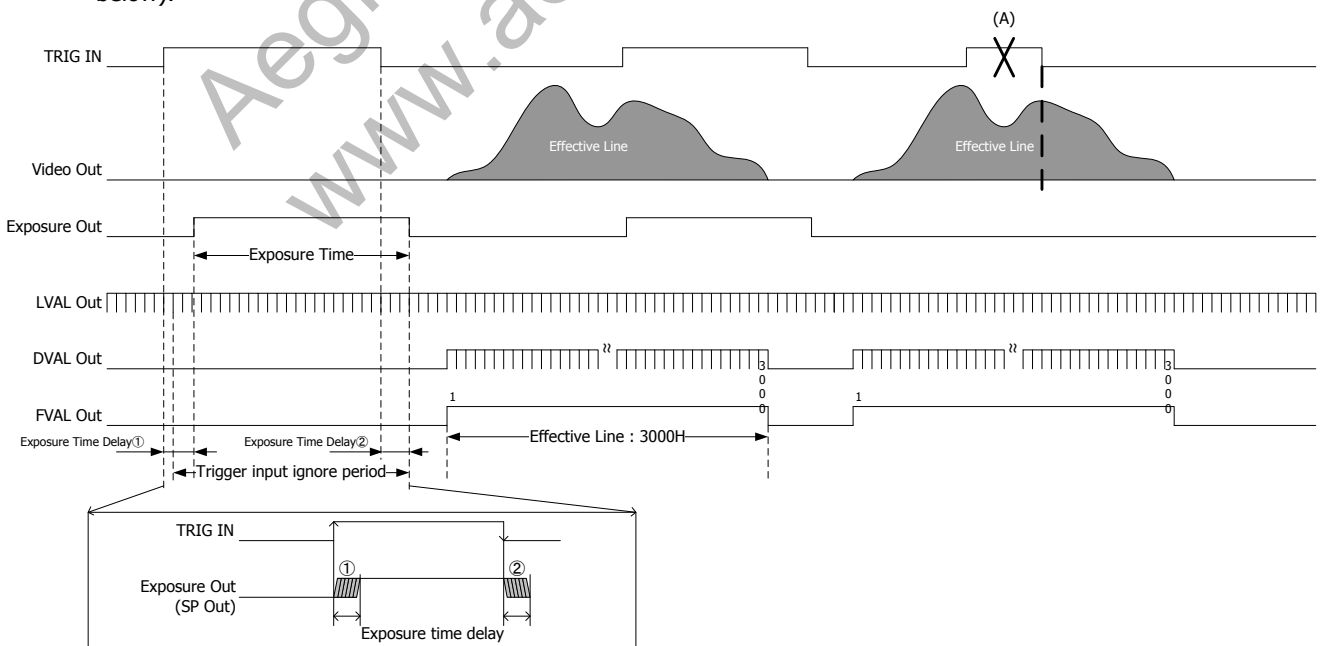

7.12. FAST Pulse Width Trigger Shutter Mode

- This is the mode to start exposure with external input trigger signals, and set the exposure time with pulse width of the trigger signals.
- Trigger operation is CLK sync., and V-sync. Reset system. The delay time (Exposure Time Delay①) from detecting trigger edge in the camera to actually starting exposure is **approx. 0.05μs**. The delay time (Exposure Time Delay ②) from detecting trigger edge in the camera to end exposure is **approx. 14.26μs**.
- Pulse width is min. **0.74μs** to approx. 2 frames. Functionally, there is no upper limitation, but noises such as dark noise shadings may be noticeable at long time exposure.
- There is an exposure time period for **approx. 14.26μs** at the edge right after the exposure output.



- Trigger input during readout time shall be ignored in the camera. (Please refer to (A) in the drawing below.)

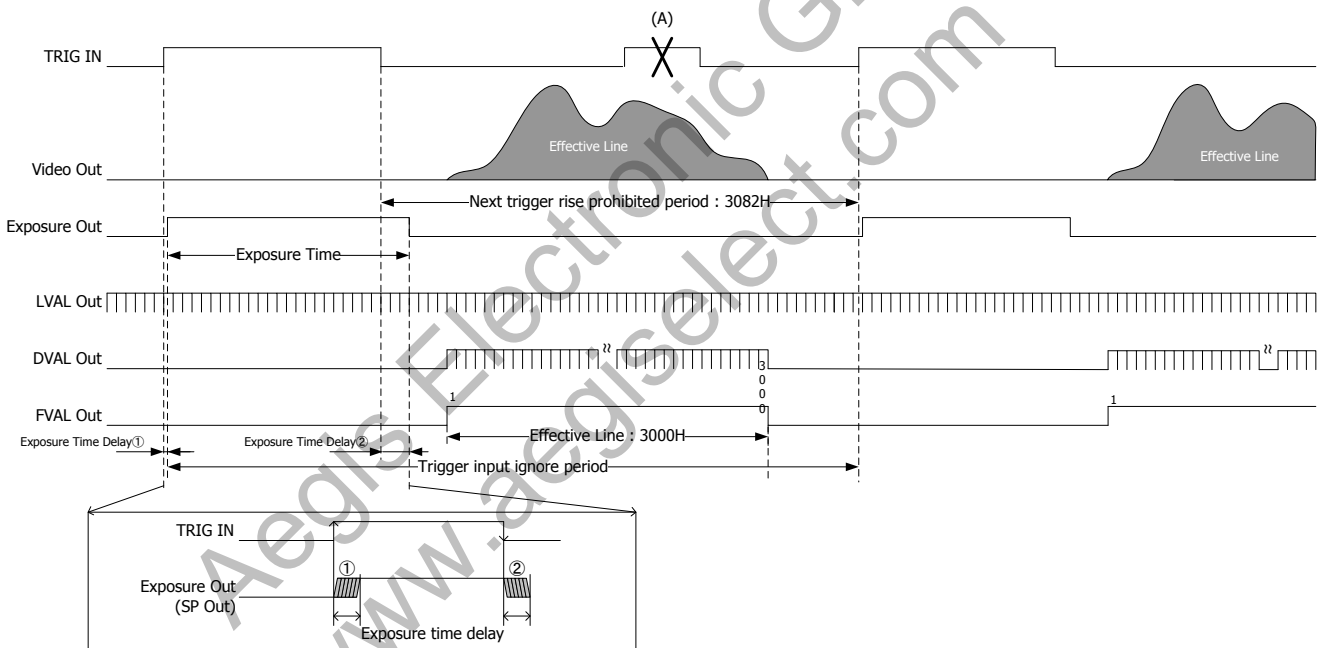

8. Partial Scan Mode

The maximum 8 partial areas can be set by serial commands

Example : 3 partial areas to be set

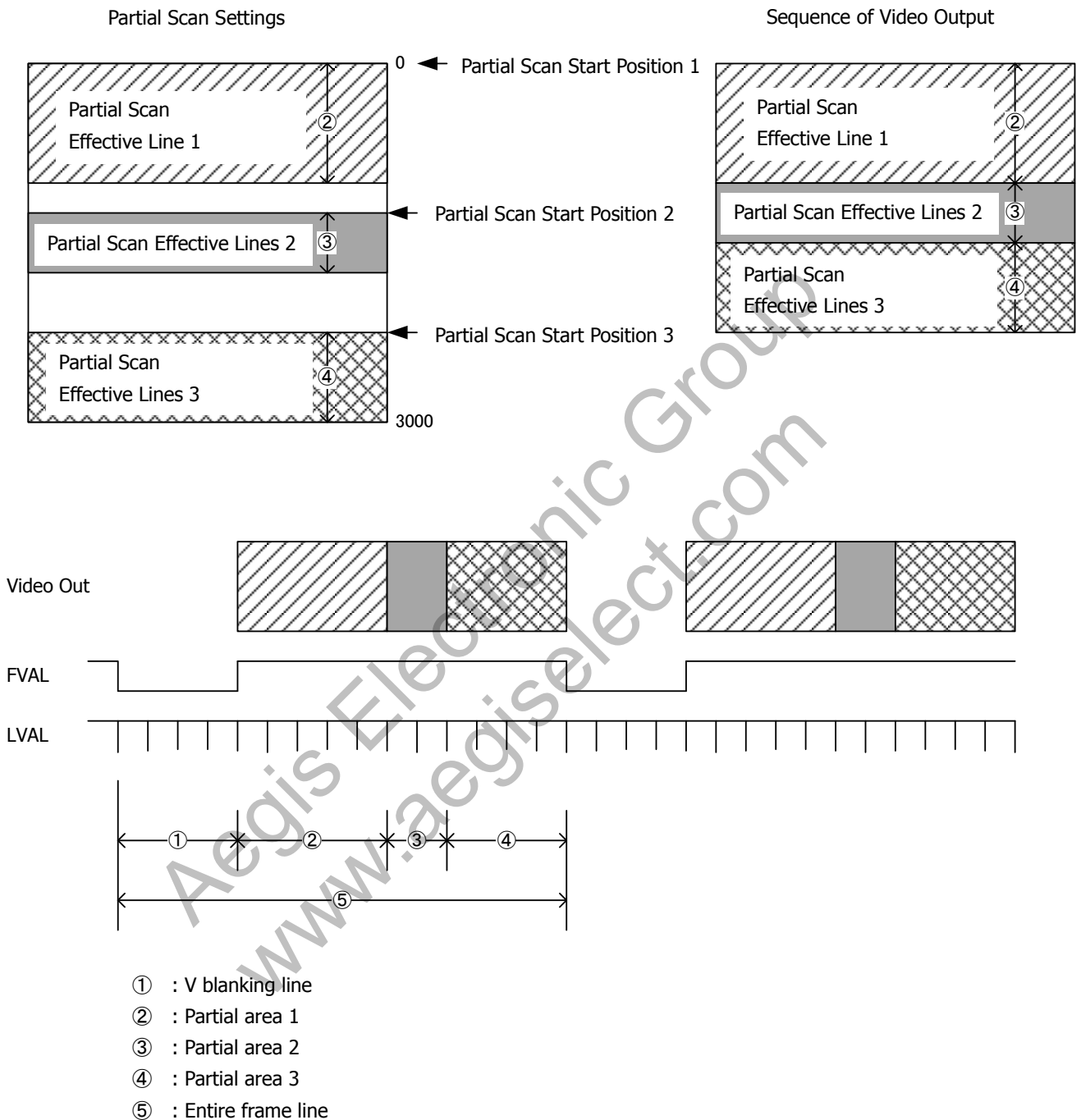

When setting several partial scan areas, please set the start position and effective lines trying not to overlap the areas.

When setting several areas, set them in ascending order of their start position.

Entire frame line count = V blanking line count + Partial effective line 1 + Partial effective lines 2 + ... + Partial effective lines 8

Please note that sum total of partial effective line count from 1 ~ 8 (except V blanking line) has to be less than 3000.

V blanking line at partial mode is **62H**.

- Frame rate = 1 / (Entire frame line count × Time for 1 line)

Time for 1 line

Camera Mode	Time for 1 Line
2Tap Configuration mode	24.512μs
4Tap Configuration mode	12.256μs
8Tap Configuration mode	6.128μs
10Tap Configuration mode	5.185μs

- Setting Example

	Effective lines	Frame rate (Entire frame line count)							
		2Tap mode		4Tap mode		8Tap mode		10Tap mode	
4 (Min.)	4 H	fps	(H)	fps	(H)	fps	(H)	fps	(H)
.	.	618.1	66	1236.3	66	2472.5	66	2922.2	66
Vertical: VGA equivalent	480 H	fps	(H)	fps	(H)	fps	(H)	fps	(H)
.	.	75.3	542	150.5	542	301.1	542	355.8	542
Vertical: XGA equivalent	768 H	fps	(H)	fps	(H)	fps	(H)	fps	(H)
.	.	49.2	830	98.3	830	196.6	830	232.4	830
Vertical: SXGA equivalent	1024 H	fps	(H)	fps	(H)	fps	(H)	fps	(H)
.	.	37.6	1086	75.1	1086	150.3	1086	177.6	1086
Vertical: UXGA equivalent	1200 H	fps	(H)	fps	(H)	fps	(H)	fps	(H)
.	.	32.3	1262	64.7	1262	129.3	1262	152.8	1262
3000 (Max.)	3000 H	fps	(H)	fps	(H)	fps	(H)	fps	(H)
Full frame		13.3	3062	26.6	3062	53.3	3062	63.0	3062

- The line numbers at partial scan setting can be set from 4 lines. Only multiple numbers of 4 can be set.
- As to the manual shutter setting value at partial scan, the effective line number becomes the maximum value.
- At partial scan setting ON/OFF, the coordinates of a cursor is reset to (0, 0).
- To change the partial setting (address 50), execute it at partial OFF.
- When you switch modes between Full frame scan mode and Partial scan mode, or when you change Partial scan settings, the first one frame right after the changes shall be invalid.

Especially at fixed trigger shutter mode and pulse width trigger shutter mode, input a dummy trigger first, and use the next trigger as an actual video signal.

9. Serial Communication Function

Via camera link serial communication function, the camera can be controlled.

(1) The settings for serial communication

Baud rate	9,600bps or 115,200bps
Data	8bit
Stop bit	1bit
Parity	None
XON/XOFF	Not controlled

(2) Control code

- The control code conforms to ASCII code.
- A control code consists of command, parameter and CR (0Dh). Changing the camera setting or acquiring the setting information can be done by issuing commands from PC.

Command	Parameter 1	Parameter 2~7	Function
GU	Address	Data 1	Obtain setting information
SU	Address	Data	Change camera settings
INIT	None	None	Restore to the factory settings
SAVE	None	None	Save the camera settings
GSI	1	None	Acquire its model name

As to the address and the data, please refer to the [Section 5. "Camera Function Settings"](#).

(3) How to set a command

- Input a command in capital letters.
- Separate between a command and a parameter by one space.
- From the head of input character to the linefeed code [¥r]or[¥n] is analyzed as one command.
- Parameter with 0x shall be analyzed by hexadecimal and parameter as is shall be analyzed by decimal.
- No decimal fraction or alphabet shall be input.
- The identifiable letters from the head are to be analyzed.
- The returned command from the PC will be received by the camera, and then echoed back.
- Please refer to [Section 5. "Camera Function Settings"](#) for the details on address and data.
- Please do not input any other numbers or words listed on [Section 5. "Camera Function settings."](#)
- Do not issue the next command until the prompt shows the completion of the prior command.

(4) Setting examples

【Example of Get Command】

To get the information of the address 21

[Send] GU[sp]21[¥r] or[¥n]

[Returned value] 50[¥r] [¥n]

[Returned value] [¥r] [¥n]

[Returned value] >[sp]

[Acquired data + Linefeed]

[Linefeed]

[Prompt + Space]

[¥r]=CR(0x0D)

[¥n]=LF(0x0A)

[sp]=Space(0x20)

【Example of Set Command】

To set 30 to the address 21

[Send] SU[sp]21[sp]30[¥r]or[¥n]

[Returned value] [¥r] [¥n]

[Linefeed]

[Returned value] >[sp]

[Prompt + Space]

- The registerable number of pixel defects and the correctable number of pixel defects may not be always the same.
 - (1) With white defects detection, if one of the strip read reached the maximum number, correction could not be performed. In such case, the data up to that point are registered, error shall be output, and the operation shall end.
 - (2) If no effective pixel exists up next to the next, down next to the next, right next to the next, or left next to the next, to the pixel to be corrected, this pixel can be registered but cannot be corrected.

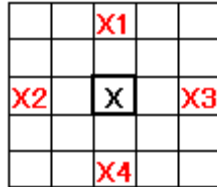

For example, when X1, X2, X3, and X4 are already registered as defected pixels, X can be added to be registered, but it cannot be corrected.

- White Defects Detection by the users (Address 100)

This is the function to register the pixels automatically if a pixel exceeds the level specified by the user. Please note that no lights should be in the sensor surface to use this function. There are two kinds of parameters for commands.

The First Parameter: Threshold (0 ~ 1023)

The data with luminance level more than the specified level here shall be registered.
 ※16 times value of the image signal level shall be specified as the threshold value.

The Second Parameter: Additional flag (0, 1)

When 0 is specified, all of user's white defects data registered by that time are cleared out, and data will be newly registered.
 When 1 is specified, only newly detected white defects data will be added to the old data registered by that time.

- ◇ Even when the Additional Flag 0 is specified, the added data with the Address 101 would not be deleted.

- Additional registration of defective pixel by users (Address 101)

This is the function to register any defective pixels specifying its coordinate. There are two parameters for commands.

The First Parameter: X Coordinate
 The Second Parameter: Y Coordinate

- ◇ When the same defected pixel as the one registered at our Ex-factory was specified, it shall be ignored.

- Deletion of defected pixels data registered by users (Address 102)

This is the function to delete the defective pixel data detected and registered by the users with specifying their coordinate. There are two parameters for commands.

The First Parameter: X Coordinate
 The Second Parameter: Y Coordinate

- ◇ Only the registered data by users, with address 100 or address 101, can be deleted.
The data registered at our Ex-factory cannot be deleted by this command.

- Entire deletion of defective pixels data registered by users (Address 103)

This is to delete all defective pixels data detected and registered by the users, with Address 100 and Address 101. Please execute this when you wish to redo your detection and registration from the beginning, or when you wish to restore all the registration to the factory settings. This can be executed by SU 103 1.

- Indication of defected pixels (Address 104)

Operation for when setting data and when acquiring data are different.

(1) When setting (SU 104)

This is the function to indicate the actually corrected pixels by that time, with 75% brightness. On/Off can be executed by parameters.

Parameter 0: OFF
Parameter 1: ON

- ◇ Bright point indication function cannot be saved.

(2) When acquiring (GU 104)

This is the function to indicate the registered defective pixels. Three kinds of lists can be indicated by parameters.

Parameter 1: Entire lists, both ex-factory data, and the added and registered data by the users, are shown.
Parameter 2: Only the list added and registered by the users is shown.

(Example of indication)

925	443	W
1228	460	W
1271	488	W
500	500	P
1098	520	W
930	629	U

From the left, X coordinate, Y coordinate, and the type of defects.

[Type of defects]

W: White defects registered at Ex-factory
B: Black defects registered at Ex-factory
U: White defects registered by the user
P: Defects added by the user

Parameter 3: Indicates the number of the registered defective pixels per CH
(Data at Ex-factory + Data registered by the user)

Parameter 4: Indicates the number of the registered defected pixels per CH
(Data registered by the user only)

[Notes for coordinate indication]

•X coordinate and Y coordinate shown are the one for the current image. When vertical partial (SU50, 54), horizontal flip (SU 11), or vertical flip (SU 12) is changed, the coordinates to be indicated shall be changed accordingly.

- The lists shown by parameters 3 and 4 are only the registered data in the currently shown image area.
(When indication image size was reduced, some registered data by the user could be out of area. In such case, the coordinate points out of the indication area would not be shown.)
- To show the coordinate points out of the area, execute parameter 1 or parameter 2. These points would be shown as minus coordinate or as the coordinate one of the out of image size.

11. User Data SAVE/Read-out Function

This is the function for users to save any data with 32 byte (Address 0~31).

Set the data to the specified address with command and issue SAVE command to save the user data. These data are not initialized by INIT command.

For the details for protocol, please refer to the [Section 9. "Serial Communication Function."](#)

11.1. Save User Data

There are two ways to write in the data.

Data shall be set per 1 byte (0~255 or 0x00~0xFF).

(1) Data writing with 1 byte

```

【Send】SU[sp]200[sp]Write address[sp]Data
【Returned value】[Yr][Yn]
【Returned value】>[sp]

```

(2) Continuous data writing

The maximum four of 1 byte (0~255 or 0x00~0xFF) data can be set with space partitions.

If more numbers than the address were set, error would occur.

```

【Send】SU[sp]200[sp]Write address[sp]Data[sp]Data[sp]Data[sp]Data
【Note】 Please make sure to insert [sp] one by one.
【Returned value】[Yr][Yn]
【Returned value】>[sp]

```

11.2. Reading Out of User Data

This is to specify the address and the number of data to be read out.

Data are shown with hexadecimal with space partitions.

When data count more than the address are specified, error would occur and it would not be read out.

```

【Send】GU[sp]200[sp]Readout address[sp]Readout count
【Returned value】0xnn[sp]0xnn[sp]0xnn[sp][Yr][Yn]
【Returned value】>[sp]

```

12. Factory Settings

Function	Address	Data
Camera Mode	1 1:	4tap Configuration mode
Output Data Selection	2 0:	8bit output
Trigger Shutter Mode	3 0:	Normal shutter mode (Free-run)
Trigger Polarity	4 0:	Positive
Trigger Input	5 0:	Camera Link CC1
FAST Trigger Mode Selection	6 0:	H sync. mode
Test Pattern Output	7 0:	OFF
Cursor Indication	8 0:	OFF
Horizontal Flip of the Output Image	11 0:	Normal
Vertical Flip of the Output Image	12 0:	Normal
Defective Pixel Correction	13 1:	ON
Serial Communication Baud Rate	14 0:	9600baud
Black Level Settings	16 0:	
Gain	20 0:	0dB
Shutter	23 0:	OFF
White Balance	30 0:	Through
Vertical Partial Mode	54 0:	OFF (3000line)

Factory setting for rear switch

Power Selection SW1 CL side

13. Sensor Optical Axis Accuracy

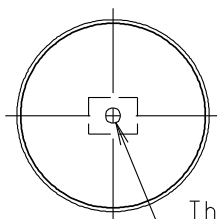
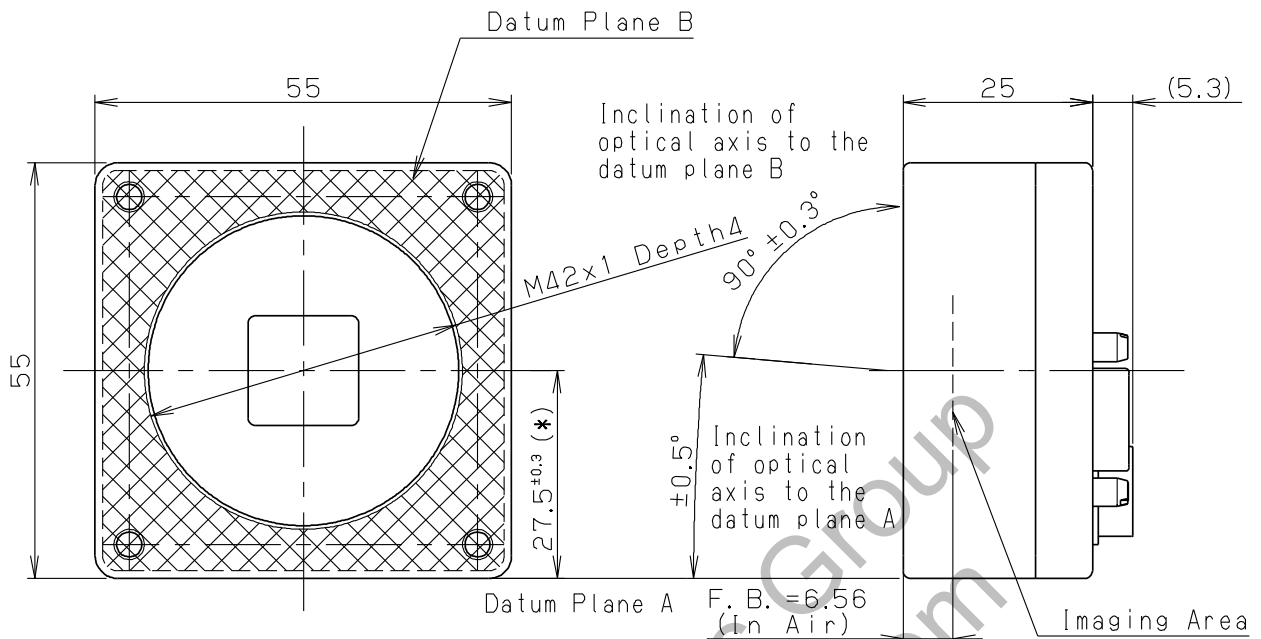

The center of the effective pixels shall be within 0.6 to the center of the lens mount.

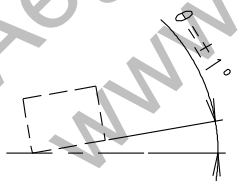

Inclination of the effective pixels θ to the datum plane is $\theta \leq \pm 1^\circ$.

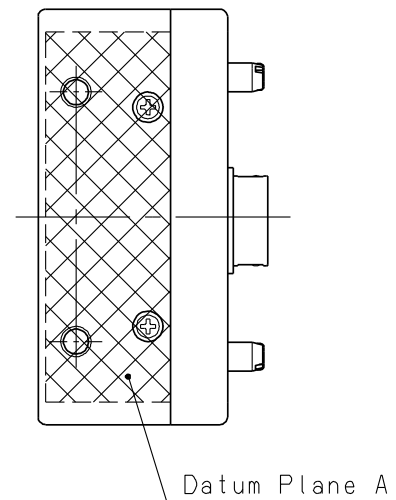

*) Dimensions from the datum plane A to the center of the lens Mount

910-017-00
(Unit : mm)

14. Dimensions

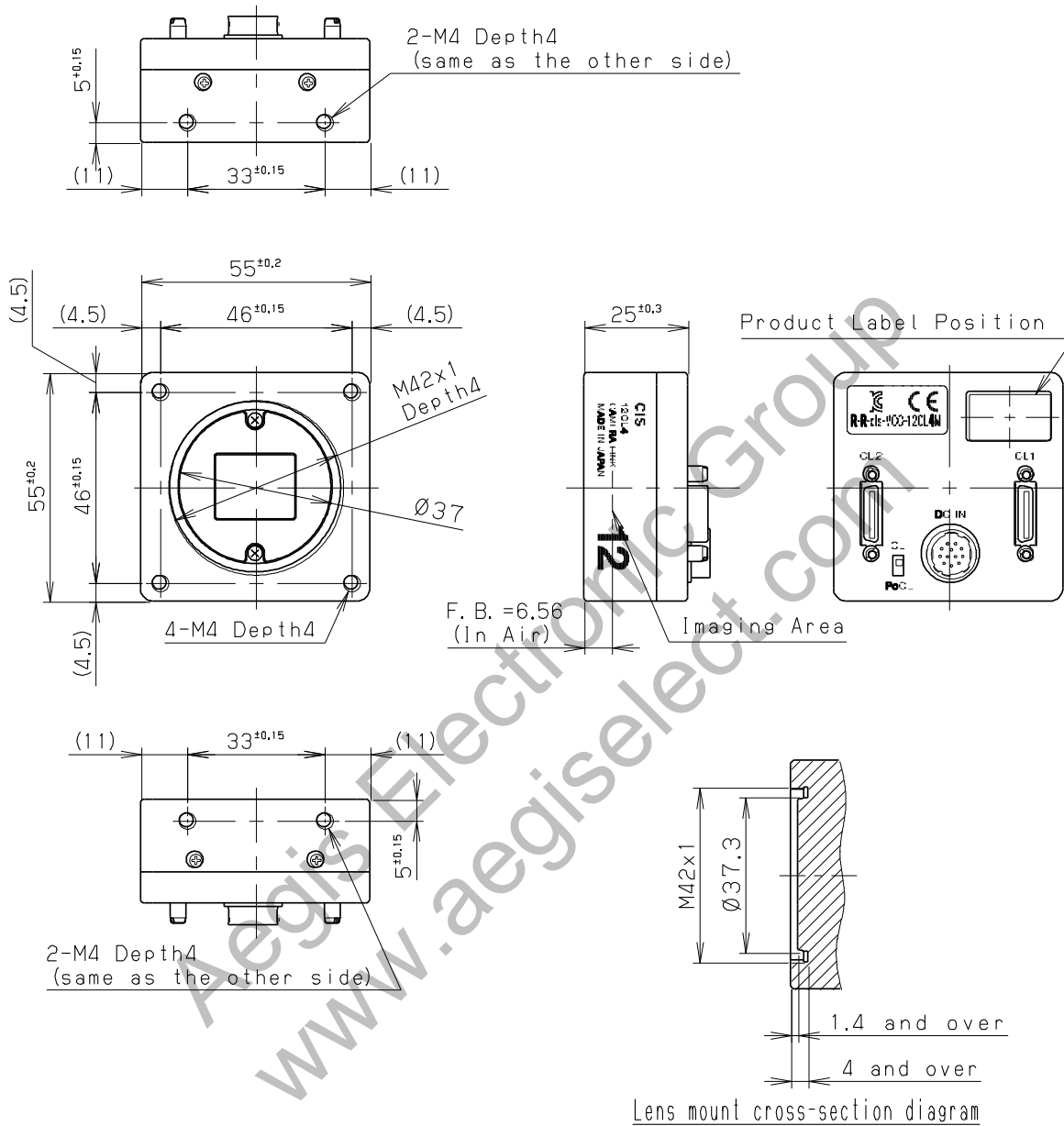

Note 2) Lens mount screw complies with M42x1.0-6H. Please refer to ISO 68-1, 965-1
(or JIS B0205-1, B0209-1).

Note 1) Please make sure the protrusion portion does not interfere with the lens selected.
Refer to the Lens mount cross-section diagram for the details.

935-0139-00
(Unit : mm)

15. Case for Indemnity

The term of warranty of this product is within 3 years from the date of shipping out from our factory.

If you use the product properly and discover a defect during the warranty period, and if that was caused by designing or manufacturing, CIS Corporation, at its option, repairs or replaces it at no charge to you. Products out of warranty period will be subject to charge. CIS repairs the products as long as it is repairable.

CIS shall be exempted from taking responsibility and held harmless for damages or losses incurred by the following cases.

- In case damages or losses are caused by earthquake, lightning strike, fire, or other acts of God.
- In case damages or losses are caused by deliberate or accidental misuse by the user, or failure to observe the information contained in the instructions in this Product Specification and Operational Manual.
- In case damages or losses are caused by repair or modification conducted by the customer or any unauthorized party.

16. CMOS Pixel Defect

CIS compensates the noticeable CMOS pixel defects found at the shipping inspection prior to our shipment. On very rare occasions, however, CMOS pixel defects might be noted with time of usage of the products. Cause of the CMOS pixel defect is the characteristic phenomenon of CMOS sensor itself and CIS is exempted from taking any responsibilities for them. Should you have any questions on CMOS pixel defects compensation please contact us.

17. Product Support

Should you have any problems in function of the product you purchased, and if you need our further analysis and/or repair, please contact the dealer you purchased it from.

18. Ordering Information

If you wish to change the default setting of baud rate, please order as the model name below.

Model name	Baud rate (bps)
VCC-12CL4R-1	115,200

19. Licensing

This camera utilizes μ T-Kernel source code in accordance with μ T-License of T-Engine forum (www.t-engine.org).