

CIS

Camera Link I/F
5.01M Pixels CMOS B/W Camera

VCC-5CL4MHS

Product Specifications & Operational Manual

CIS Corporation

©2017 CIS Corporation. All rights reserved.

Table of Contents

| | PAGE |
|--|------|
| 1. Handling Precautions | 2 |
| 2. Product Outline | 3 |
| 3. System Configuration..... | 3 |
| 3.1. Camera | 3 |
| 3.2. Optional Accessories | 3 |
| 3.3. Free Software..... | 3 |
| 3.4. Packaging | 3 |
| 4. Specifications | 4 |
| 4.1. General Specifications | 4 |
| 4.2. Camera Input and Output Signals Specifications | 5 |
| 4.3. CMOS Spectral Response | 6 |
| 4.4. Video Output Format | 6 |
| 5. Camera Function Settings | 7 |
| 5.1. The List of Preset Shutter | 9 |
| 5.2. Formula to Calculate Manual Shutter Values at H Sync mode..... | 9 |
| 5.3. Manual Shutter Settings with CLK Sync Mode (FAST Trigger Mode)..... | 9 |
| 5.4. Notes for Function Settings | 9 |
| 6. External Connector Pin Assignment | 10 |
| 6.1. 12pins Circular Connector HR10-10R-12PA(73) (HIROSE) or equivalent..... | 10 |
| 6.2. Camera Link Connector 12226-1100-00PL (SUMITOMO 3M)..... | 11 |
| 6.3. PoCL/CL Selection Switch (SW1)..... | 11 |
| 7. Timing Chart..... | 12 |
| 7.1. Horizontal Synchronous Signals Timing (10Tap8bit Configuration) | 12 |
| 7.2. Vertical Synchronous Signals Timing (10Tap8bit Configuration) | 12 |
| 7.3. Fixed Trigger Shutter Mode | 13 |
| 7.4. FAST Fixed Trigger Shutter Mode..... | 14 |
| 7.5. Pulse Width Trigger Shutter Mode | 15 |
| 7.6. FAST Pulse Width Trigger Shutter Mode..... | 16 |
| 8. Partial Scan Mode..... | 17 |
| 9. Remote Communication Function | 19 |
| 10. Pixel Defect Correction..... | 21 |
| 11. User Data SAVE/Read Out Function | 24 |
| 11.1. SAVE User Data..... | 24 |
| 11.2. Reading Out of User Data | 24 |
| 12. Factory Settings | 25 |
| 13. Sensor Optical Axis Accuracy..... | 26 |
| 14. Dimensions | 27 |
| 15. Case for Indemnity (Limited Warranty) | 28 |
| 16. CMOS Pixel Defect..... | 28 |
| 17. Product Support | 28 |
| 18. Ordering Information..... | 28 |
| 19. Licensing | 28 |

1. Handling Precautions

The camera must not be used for any nuclear equipments or aerospace equipments with which mechanical failure or malfunction could result in serious bodily injury or loss of human life. Our warranty does not apply to damages or defects caused by irregular and/or abnormal use of the product.

Please observe all warnings and cautions stated below.

Our warranty does not apply to damages or malfunctions caused by neglecting these precautions.

- Do not use or store the camera in the extremely dusty or humid places.
- Do not apply excessive force or static electricity that could damage the camera.
- Do not shoot direct images that are extremely bright (e.g., light source, sun, etc.), and when camera is not in use, put the lens cap on.
- Follow the instructions in Chapter 6, "External connector pin assignment" for connecting the camera. Improper connection may cause damages not only to the camera but also to the connected devices.
- Confirm the mutual ground potential carefully before connecting the camera to monitors or computers. Any AC leaks from the connected devices may cause damages or destroy the camera.
- Do not apply excessive voltage. (Use only the specified voltage.) Unstable or improper power supply voltage may cause damages or malfunction of the camera.
- The voltage ripple of camera power DC $+12V \pm 10\%$ shall be within $\pm 50mV$. Improper power supply voltage may cause noises on the video signals.
- The rising time of camera power supply voltage shall be less than $+10V$, Max 60ms. Please avoid noises like chattering when rising.

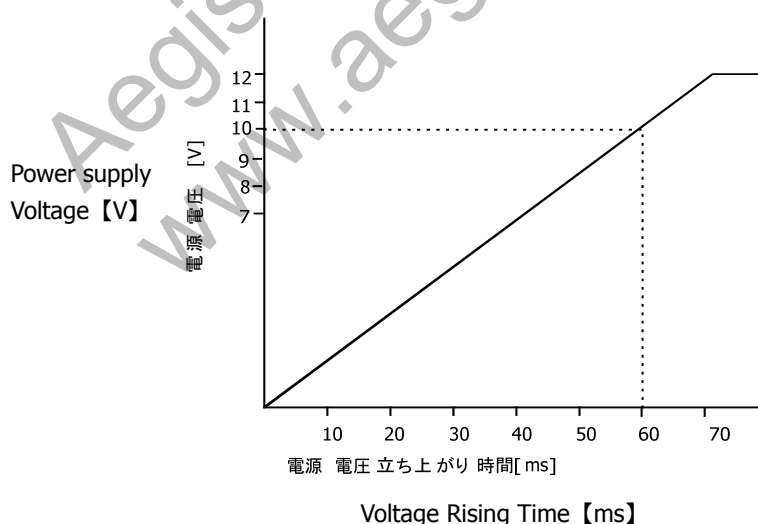

2. Product Outline

VCC-5CL4MHS is a Camera Link interfaced and 5M resolution, small industrial B/W camera module. 5.01M pixels, 2/3 type (diagonal length 11.1mm) B/W CMOS sensor is utilized. Video is output with 10 Tap 8 Bit Configuration. Entire pixels can be read out at 1/163.4s with Full Configuration output.

Features

- Global shutter CMOS sensor
- Camera Link 10tap 8 bit is supported
- Fixed trigger shutter mode, Pulse width trigger shutter mode
- Full frame rate and video output are as below.

| | | |
|--------------------------|-----------|------|
| 10Tap Base Configuration | 163.4 fps | 8bit |
|--------------------------|-----------|------|

3. System Configuration

3.1. Camera

- Camera, VCC-5CL4M

3.2. Optional Accessories

- M42-C Lens mount conversion ring
- M42-F Lens mount conversion ring

3.3. Free Software

- CIS control panel software for evaluation purpose only is downloadable via our web.

3.4. Packaging

- Individual Carton
- Master Carton (20pcs/carton)

Note) Master carton may vary depends on the quantity to be shipped.

4. Specifications

4.1. General Specifications

| | | | | | |
|-----------------------------------|---|--|-----------------------------|------------------|--------|
| (1) Pickup device | Device Type Effective pixel number Unit cell size | Diagonal length 11.1mm type (2/3type) Global shutter B/W CMOS 2448(H) x 2048(V) 3.45 μ m(H) x 3.45 μ m(V) | | | |
| (2) Video output frequency | Pixel Clock | 84.86 MHz | | | |
| | 10Tap 8bit Configuration mode: | Horizontal Frequency | 342.2kHz | Horizontal Clock | 248CLK |
| | | Vertical Frequency | 163.4 Hz | Scanning Lines | 2094 H |
| (3) Sync system | Internal Sync. System. | | | | |
| (4) Video output | 10Tap 8bit Configuration | | | | |
| (5) Resolution | 2048TV Lines | | | | |
| (6) Output format | Sensor AD | 8bit | | | |
| | Camera Link output | 8bit B/W output | | | |
| (7) Sensitivity | F4 400lx (Shutter speed 1/167s (OFF), Gain 0dB, 10tap8bit Configuration mode) | | | | |
| (8) Minimum illumination | F1.4 0.42lx (Shutter speed 1/167s(OFF), Gain+24dB,10tap8bit Configuration mode) | | | | |
| (9) Power requirements | DC+12V \pm 10% 12pins circular connector or PoCL | | | | |
| (10) Power consumption (Typ) | 3.3W (DC+12V IN, 10Tap8bit Configuration mode, Full frame scan output) | | | | |
| (11) Dimensions | Refer to overall dimension drawing. (H:55mm W:55mm D:25mm excluding projection) | | | | |
| (12) Weight | Approx. 100g | | | | |
| (13) Lens mount | M42 mount ※Refer to overall dimension drawing. | | | | |
| (14) Optical axis accuracy | Refer to drawing for CMOS Optical Axis Accuracy. | | | | |
| (15) Gain variable range | 0dB ~ +24dB (Guaranteed range) | | | | |
| (16) Shutter speed variable range | OFF ~ 1/60,000s | | | | |
| (17) Trigger shutter mode | Fixed Shutter Trigger Mode, Pulse Width Shutter Trigger Mode | | | | |
| (18) Partial scan | Full frame scan ~4 lines (4 lines/step) | | | | |
| (19) Safety/Quality standards | UL: Conform to UL Standard including materials and others. | | | | |
| | CE: Emission : To be applied for EN55022:2010(Class A) | | | | |
| | Immunity : To be applied for EN61000-6-2:2005 | | | | |
| | RoHS: Conform to RoHS. | | | | |
| (20) Durability | Vibration | Acceleration | : 98m/s ² (10G) | | |
| | | Frequency | : 20~200 Hz | | |
| | | Direction | : X,Y, and Z 3 directions | | |
| | | Testing time | : 120min for each direction | | |
| | Shock | No malfunction shall be occurred with 980m/s ² (100G) for \pm X, \pm Y, and \pm Z, 6 directions. | | | |
| (21) Operational environment | Temperature: | Performance guaranteed temperature: 0°C~+40°C | | | |
| | | Camera operation guaranteed temperature: -5°C~+45°C | | | |
| | Humidity: | RH 20~80% with no condensation. | | | |
| | | ※All the specifications specified in this manual is guaranteed under performance guaranteed temperature. ※All the camera functions operate normally under operation guaranteed temperature. | | | |
| (22) Storage environment | Temperature: | -25°C~+60°C | | | |
| | Humidity: | RH 20~80% with no condensation. | | | |

4.2. Camera Input and Output Signals Specifications

| | | |
|--------------------------|---|--|
| (1)Video Output Data | Effective Video Output | 2448(H) × 2048(V) At full frame scan mode |
| (2) Sync. Signal output | LVAL :No. 6 pin FVAL :No. 7 pin EXPOSURE :No. 9 pin DVAL :No.10pin | 12pins circular connector (LVTTTL output) |
| | LVAL FVAL | Camera Link output (LVDS) |
| (3)Trigger input | Polarity | Positive/Negative selectable |
| | Pulse width | 1H(min) ~Approx. 2 frames Functionally, no upper limitation is set but at long time exposure, dark noises and shading noises might be noticeable. |
| | Trigger input :No.11 pin :CC1 | 12pins circular connector (LVTTTL) Camera Link input (LVDS) |
| (5)Serial communications | SerTC (Serial to Camera) | Camera Link input (LVDS) |
| | SerTFG (Serial to Frame Grabber) | Camera Link output (LVDS) |
| Video signals | White Clip Level | At Digital 8bit : FFh |
| | Setup Level | At Digital 8bit : 2±1h (Condition: Gain 0dB) |
| | Dark Shading | At Digital 8bit : Both horizontal and vertical should be under 04h. (Condition: Gain 0dB) |

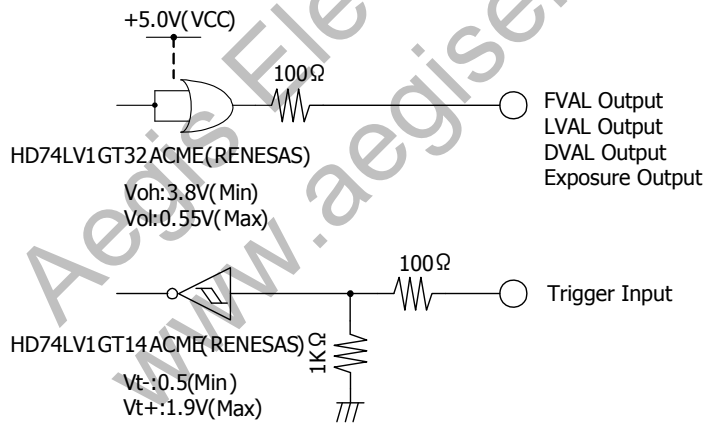

IO Interface of 12pins Circular connector at rear

4.3. CMOS Spectral Response

※The lens characteristics and illuminant characteristics are excluded.

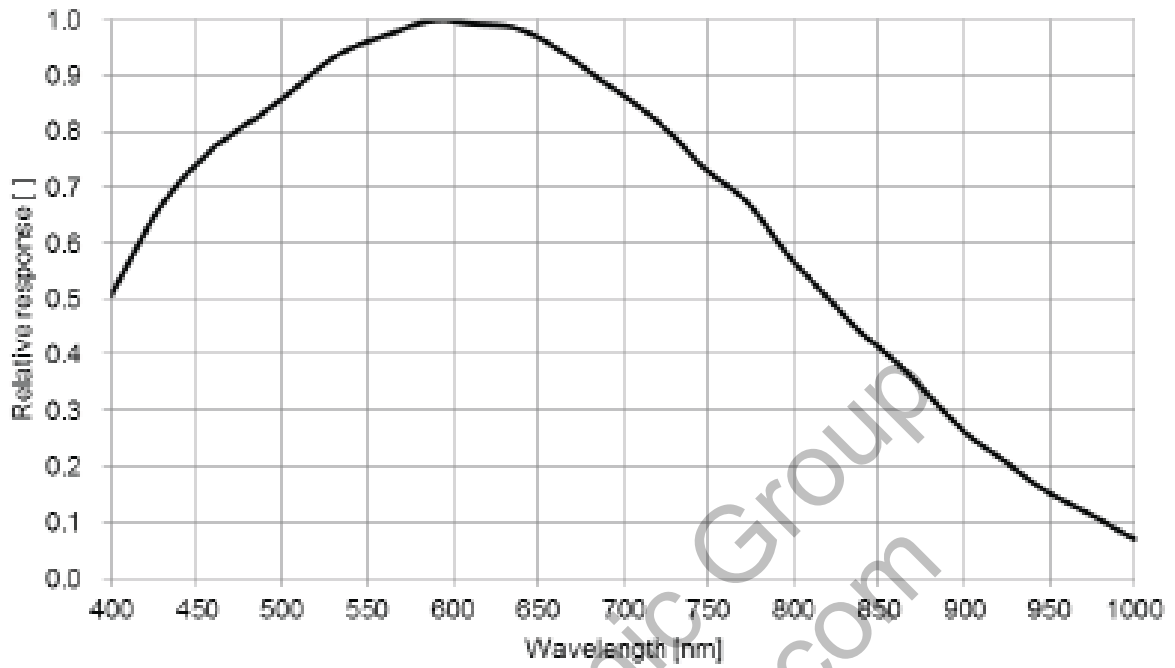

4.4 Video Output Format

(1) 10Tap 8bit Configuration Mode : 163.4fps

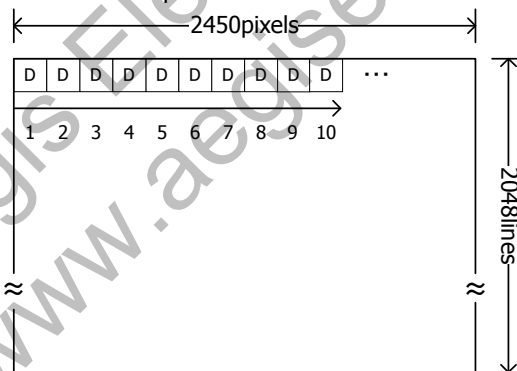

5. Camera Function Settings

Camera functions can be set with serial communications.

| Function | Address | Data | Description |
|---|---------|----------|---|
| Trigger Shutter Mode ※FAST trigger mode is forced to be disabled at normal shutter mode. To enable FAST trigger mode, fixed trigger shutter mode or pulse width trigger shutter model shall be selected | 3 | 0 | Normal shutter mode (Free-run) (Shutter speed can be set with address 23 and 24). |
| | | 1 | Fixed trigger shutter mode (Shutter speed can be set with address 23 and 24). |
| | | 2 | Pulse width trigger shutter mode (Shutter speed can be set with trigger pulse width). |
| Trigger Polarity | 4 | 0 | Positive |
| | | 1 | Negative |
| Trigger Input | 5 | 0 | Camera Link CC1 |
| | | 1 | 12pins circular connector No. 11 pin (TTL) |
| FAST trigger mode selection ※Trigger mode to capture the trigger input with H cycle or the mode to capture the trigger input with CLK sync is switchable. However, please be noted that overlapped operation cannot be operative at CLK sync mode. This mode is effective to avoid hunting at high speed shutter operation. Valid only when the address 3 is 1 or 2 | 6 | 0 | H sync mode (Trigger is taken with H sync). ※A trigger during outputting images can be input (Overlap operation is doable). ※Exposure time during normal shutter mode and fixed trigger shutter mode can be set per H. |
| | | 1 | FAST trigger mode (Trigger is taken with CLK sync). ※A trigger during outputting images cannot be input (Overlap operation is not doable). ※Exposure time of manual shutter during fixed trigger shutter mode is changed to be set per μ s (approximate value). |
| Test Pattern | 7 | 0 | OFF |
| | | 1 | Gray scale (Valid only when cursor is OFF) |
| | | 2 | Horizontal ramp (Valid only when cursor is OFF) |
| | | 3 | Vertical ramp (Valid only when cursor is OFF) |
| Cursor Display ON/OFF | 8 | 0 | OFF |
| | | 1 | ON (Cursor output has its priority when test pattern output is ON). |
| Cursor X Coordinate | 9 | 0 ~ 2447 | Horizontal 2448 pixels (Factory setting is 0. Reset to 0,0 when operating coordinate related settings.) |
| Cursor Y Coordinate | 10 | 0 ~ 2047 | Vertical 2048 lines (Factory setting is 0. Reset to 0,0 when operating coordinate related settings.) |
| Output image horizontal flip | 11 | 0 | Normal |
| | | 1 | Horizontal flip |
| Output image vertical flip | 12 | 0 | Normal |
| | | 1 | Vertical flip |
| Defective pixel correction | 13 | 0 | OFF |
| | | 1 | ON |
| Serial communications Baud rate selection ※INIT Command is excluded | 14 | 0 | 9,600 baud |
| | | 1 | 115,200 baud |
| Black Level Adjustment | 16 | 0~25 | Black level adjustment (To be restored to the factory settings with INIT command). |

| Function | Address | Data | Description |
|---|---------|--|---|
| Gain | 20 | 0 | 0dB fixed gain |
| | | 1 | + 6dB fixed gain |
| | | 2 | +12dB fixed gain |
| | | 3 | +18dB fixed gain |
| | | 4 | +24dB fixed gain |
| | | 5 | +30dB fixed gain |
| | | 6 | +36dB fixed gain |
| | | 11 | Manual gain (Refer to the address 21) |
| Manual gain | 21 | 0~480 | 0 ~ + 48dB (1dig=0.1dB) |
| Shutter | 23 | 0 ~ 15 | Preset shutter (Refer to Section 5.1. The List of Preset Shutter) |
| | | 16 | Manual shutter (Refer to the address 24) |
| Manual shutter | 24 | 1 ~ 2048 | 1line/step (Refer to Section 5.2. Formula to Calculate Manual Shutter Values) |
| Manual shutter at FAST trigger | | 14 ~200,000 | Specify exposure time with μ s (approximate value). Refer to the manual shutter settings of FAST trigger mode (CLK sync mode). |
| Vertical partial (lump settings) | 50 | 3 parameters | The 1 st parameter: Partial number (0~7) The 2 nd parameter: Start line (0~2044 per 4 lines) The 3 rd parameter: Effective line numbers (4~2048 per 4 lines) |
| | | 1 parameter at acquisition | Specify the partial numbers (0~7). |
| Vertical partial mode | 54 | 0 | OFF |
| | | 1 | Reflect the value set by the address 50, then set vertical partial ON. |
| Factory settings | INIT | None | Restore the settings to the factory settings. |
| Data save | SAVE | None | Save the camera settings. |
| White defect detection by users | 100 | 2 Parameters | Detect the later occurred white defects and register them. |
| Addition of defect pixels by users | 101 | 2 Parameters | Register the defective pixels specified with (x, y). |
| Deletion of defect pixels by users | 102 | 2 Parameters | Delete the defective pixels specified with (x, y). |
| Complete deletion of defect pixels by users | 103 | 1 (fixed) | Delete all the defect pixels detected and registered by the user. |
| Indication of defect pixels | 104 | 0 at set up | Turn OFF the indication of bright point |
| | | 1 at set up | Indicate the position of the correcting pixel with lighting. |
| | | 1 at setup | Indicate the list of data at ex-factory and the registered data by the user. |
| | | 2 at setup | Indicate only the list of the registered data by the user. |
| | | 3 at setup | Indicate the registered number of the defect pixels per reed. |
| | | 4 at setup | Line up and indicate the registered number of the defect pixels per reed. |
| User data settings | 200 | 2 Parameters All 0xFF at Ex-Factory | Set any data for the user area (32 byte). Save with SAVE command. |

※Do not set any address or data other than specified the above.

5.1. The List of Preset Shutter

| 2450x2048 | |
|-----------|------------|
| Data | 10Tap8bit |
| 0~3 | 1/167(OFF) |
| 4 | 1/200 |
| 5 | 1/250 |
| 6 | 1/500 |
| 7 | 1/1000 |
| 8 | 1/2000 |
| 9 | 1/2500 |
| 10 | 1/5000 |
| 11 | 1/10000 |
| 12 | 1/15000 |
| 13 | 1/25000 |
| 14 | 1/51000 |
| 15 | 1/60000 |

5.2. Formula to Calculate Manual Shutter Values at H Sync mode

Formula : Exposure Time = Time for 1 line (Refer to the below) x Address 24 set value + 13.73 μ s

| Camera Mode | Time for 1 line |
|-------------------------|-----------------|
| 10Tap8bit Configuration | 2.923 μ s |

※ The minimum setting value shall be 1 and the maximum setting value shall be clipped with 2048 or the total line number for partial settings.

5.3. Manual Shutter Settings with CLK Sync Mode (FAST Trigger Mode)

- The minimum setting value: 14 μ s (approximate value)
- The maximum setting value: 200ms (approximate value)
- ※With long exposure setting, bright spot may be noticeable.
- Setting unit: Per 1 μ s (approximate value)
- ※Slight differences may occur since it is generated by 74.25MHz clock.

5.4. Notes for Function Settings

- ※ 2 seconds shall be waited after power is turned on for the camera to operate properly.
- ※ Please be noted that Vertical flip, horizontal flip, and partial setting command cannot be reflected right away. Dummy triggers are needed at trigger mode.
- ※ When gain settings + 24dB is exceeded, deterioration in the image quality is inevitable. We recommend you to evaluate it first to use.

6. External Connector Pin Assignment

6.1. 12pins Circular Connector HR10-10R-12PA(73) (HIROSE) or equivalent

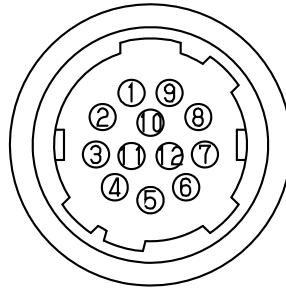

| Pin No. | Description |
|---------|----------------------|
| 1 | GND |
| 2 | Power Input (DC+12V) |
| 3 | GND |
| 4 | NC |
| 5 | GND |
| 6 | LVAL Output |
| 7 | FVAL Output |
| 8 | GND |
| 9 | Exposure Output |
| 10 | DVAL Output |
| 11 | TRIGGER Inputs |
| 12 | GND |

6.2. Camera Link Connector 12226-1100-00PL (SUMITOMO 3M)

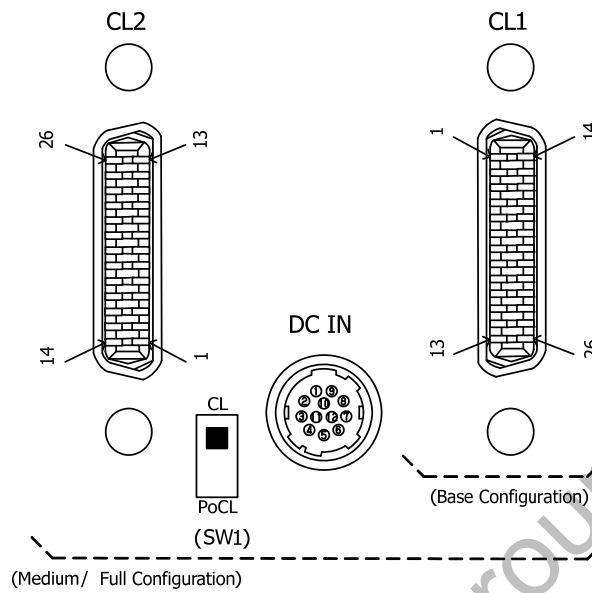

Connector (CL2)

| Pin No. | Description | Pin No. | Description |
|---------|---------------|---------|---------------|
| 1 | NC/+12V(PoCL) | 14 | GND |
| 2 | Y0- | 15 | Y0+ |
| 3 | Y1- | 16 | Y1+ |
| 4 | Y2- | 17 | Y2+ |
| 5 | Yclk- | 18 | Yclk+ |
| 6 | Y3- | 19 | Y3+ |
| 7 | 100Ω | 20 | Terminated |
| 8 | Z0- | 21 | Z0+ |
| 9 | Z1- | 22 | Z1+ |
| 10 | Z2- | 23 | Z2+ |
| 11 | Zclk- | 24 | Zclk+ |
| 12 | Z3- | 25 | Z3+ |
| 13 | GND | 26 | NC/+12V(PoCL) |

Connector (CL1)

| Pin No. | Description | Pin No. | Description |
|---------|---------------------|---------|---------------------|
| 1 | NC/+12V(PoCL) | 14 | GND |
| 2 | X0- | 15 | X0+ |
| 3 | X1- | 16 | X1+ |
| 4 | X2- | 17 | X2+ |
| 5 | Xclk- | 18 | Xclk+ |
| 6 | X3- | 19 | X3+ |
| 7 | SerTC+ | 20 | SerTC- |
| 8 | SerTFG- | 21 | SerTFG+ |
| 9 | CC1- (Trigger IN -) | 22 | CC1+ (Trigger IN +) |
| 10 | CC2+ | 23 | CC2- |
| 11 | CC3- | 24 | CC3+ |
| 12 | CC4+ | 25 | CC4- |
| 13 | GND | 26 | NC/+12V(PoCL) |

6.3. PoCL/CL Selection Switch (SW1)

- (1) PoCL...To be selected when a PoCL frame grabber board is used and power is fed via the frame grabber board.
- (2) CL... To be selected when Non-PoCL frame grabber board is used.

Please make sure that power is OFF when changing the switch settings. If the switch setting was changed while power is ON, it may cause malfunction or damages to the camera.

7. Timing Chart

7.1. Horizontal Synchronous Signals Timing (10Tap8bit Configuration)

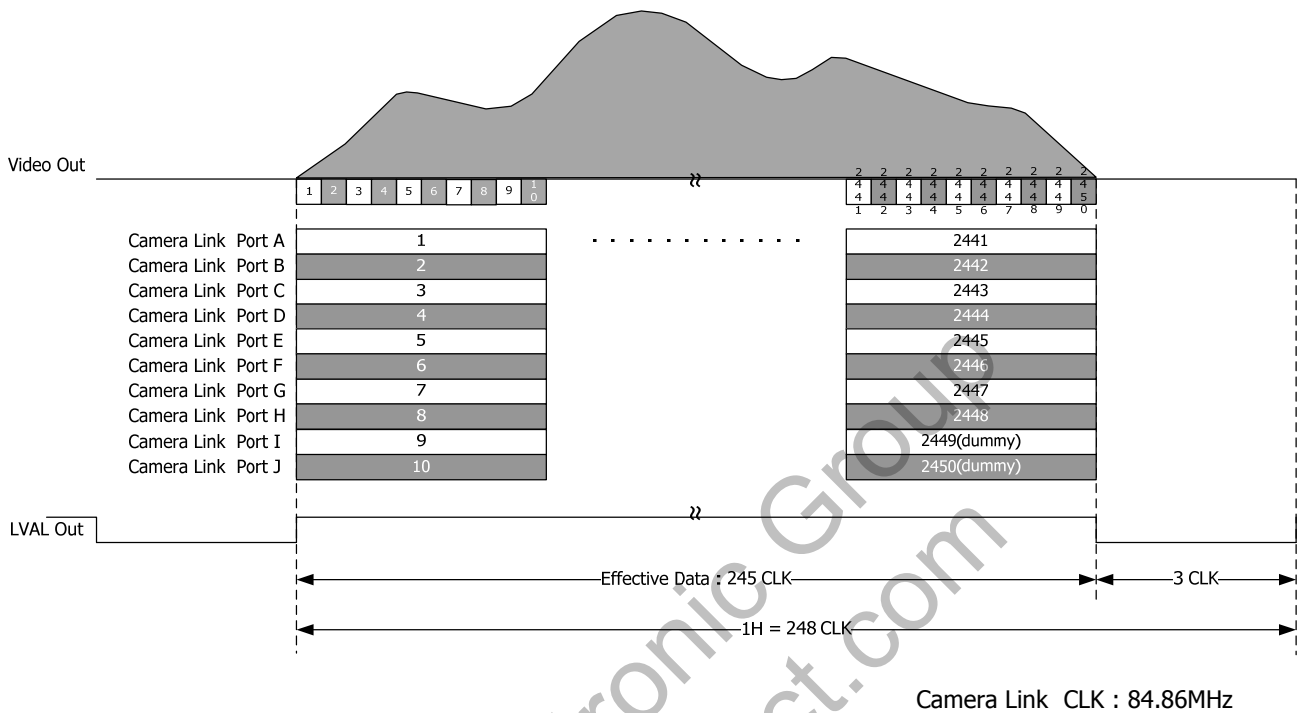

7.2. Vertical Synchronous Signals Timing (10Tap8bit Configuration)

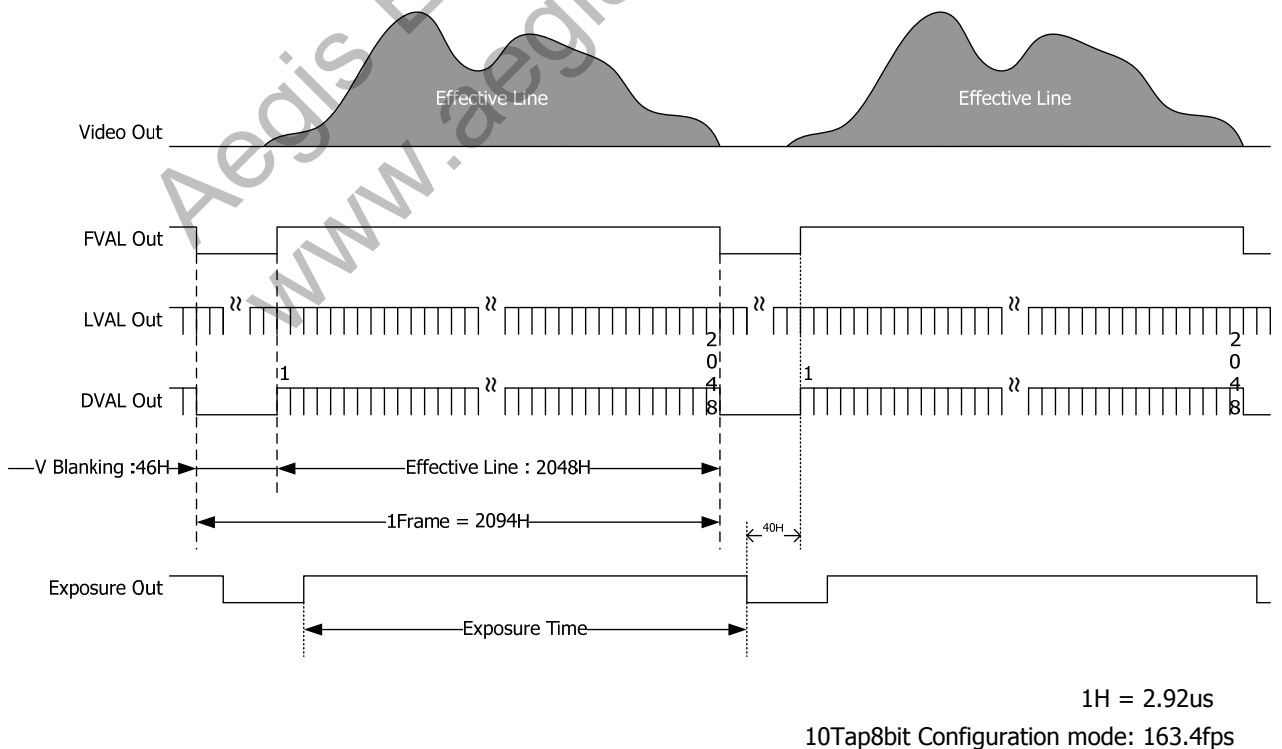

7.3.Fixed Trigger Shutter Mode

- This is the mode to start exposure with external input trigger signals, and set the exposure time with serial commands.
- Trigger operation is H Sync, and V-sync Restart system

The delay time (Exposure Time Delay) from detecting trigger edge in the camera to starting exposure is 2H~3H.

Since the external trigger signals sync with camera internal H signals, 1H jitter occurs to Exposure Time Delay.

The trigger pulse with the minimum 1H and more shall be input (Refer to the below for the details of 1 line width).

| Camera Mode | Time for 1 line |
|-------------------------|-----------------|
| 10Tap8bit Configuration | 2.923 μ s |

- There is an exposure time period for approx. 13.73 μ s at the edge right after exposure output.



- Triggers can be accepted while outputting video output images. However, please be noted that a trigger signal to start the next video outputting before completion of outputting the prior images should not be input.
- Trigger input during exposure time shall be ignored in the camera. (Refer to (A) in the drawing below).

Note that a trigger shorter than 1 frame cycle shall not be used.

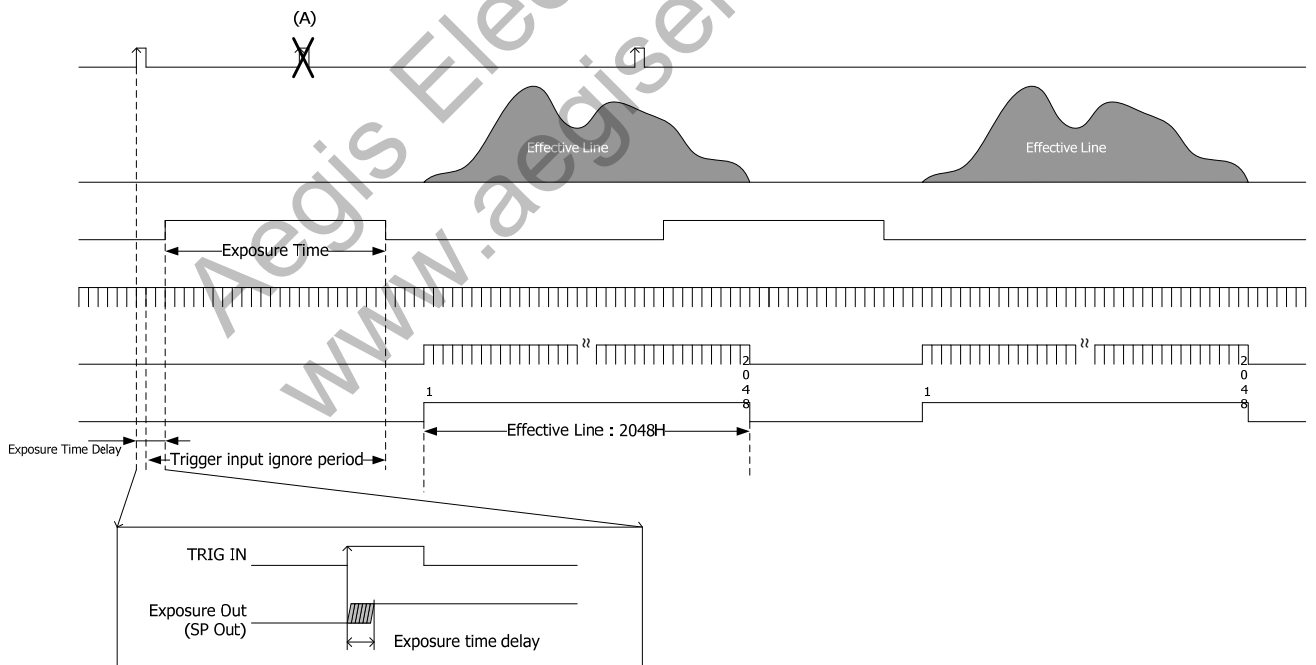

7.4. FAST Fixed Trigger Shutter Mode

- This is the mode to start exposure with external input trigger signals, and set the exposure time with serial commands.
- Trigger operation is CLK Sync, and V-sync Restart system.

The delay time (Exposure Time Delay) from detecting trigger edge in the camera to starting exposure is approx. 0.05 μ s. Input more than 1 μ s width pulse as a trigger.

- There is an exposure time period for approx. 13.73 μ s at the edge right after exposure output.



- Trigger input while outputting images cannot be accepted.

Trigger input during exposure time and video outputting shall be ignored in the camera. (Refer to (A) and (B) in the drawing below).

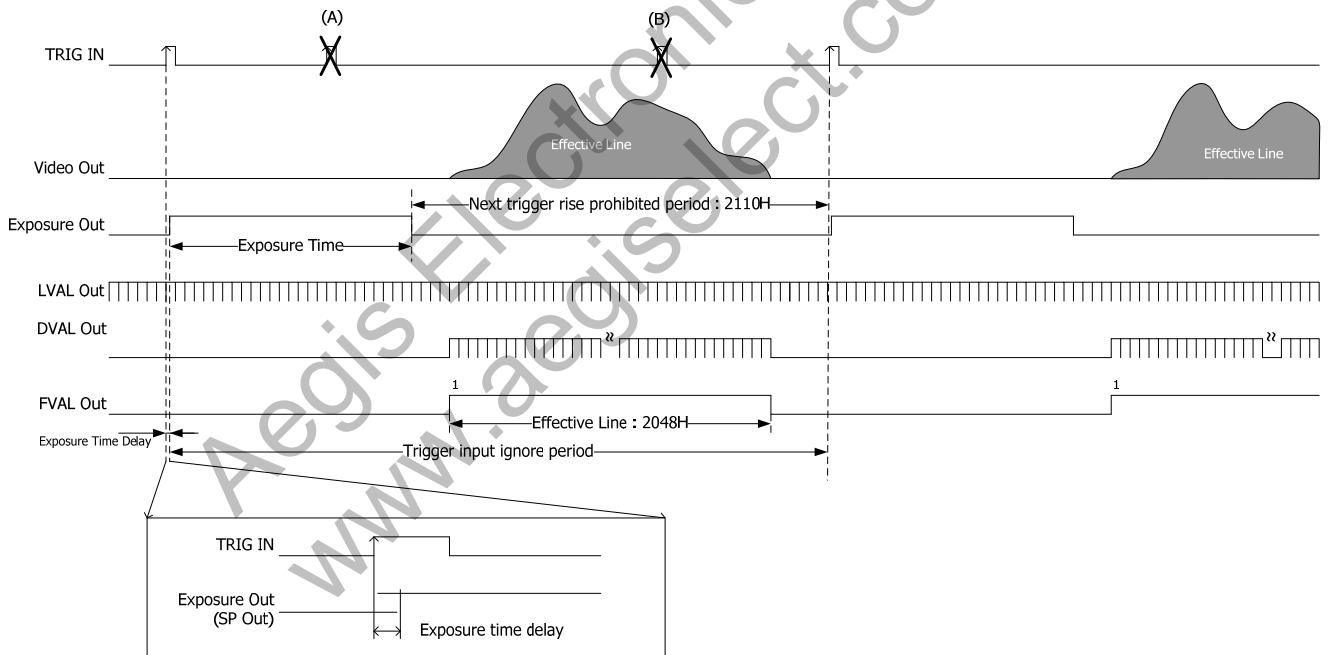

7.5. Pulse Width Trigger Shutter Mode

- This is the mode to start exposure with external input trigger signals, and set the exposure time with pulse width of the trigger signals.
- Trigger operation is H Sync, and V-sync Restart system.
 The delay time (Exposure Time Delay①) from detecting trigger edge in the camera to starting exposure is 2H~3H.
 The delay time (Exposure Time Delay②) from detecting trigger edge in the camera to end exposure is 2H+13.73 μs~3H+13.73 μs.
- Since the external trigger signals sync with camera internal H signals, 1H jitter occurs to Exposure Time Delay ① and ②. In case of pulse width trigger mode, jitters may occur at the both start and end edges of exposure. At this time, exposure time would change so that flicker might be noticeable in the image, especially when high speed shutter is set. This flicker sometimes can be eliminated when fixed trigger shutter mode is used. However, this problem can be solved by inputting a trigger pulse with synchronizing it to the camera internal H cycle (LVAL).
- Pulse width is min. 1H to approx 2 frames. Functionally, there is no upper limitation, but noises such as dark noises shadings may be noticeable at long time exposure.
- There is an exposure time period for approx. 13.73 μs at the edge right after exposure output.



- Trigger input during exposure time shall be ignored in the camera. However, a trigger shorter than 1 frame cycle shall not be used.
- Triggers can be accepted while outputting video output images. However, please be noted that a trigger signal to start the next video outputting before completion of outputting the prior images should not be input. (Refer to (A) in the drawing below).

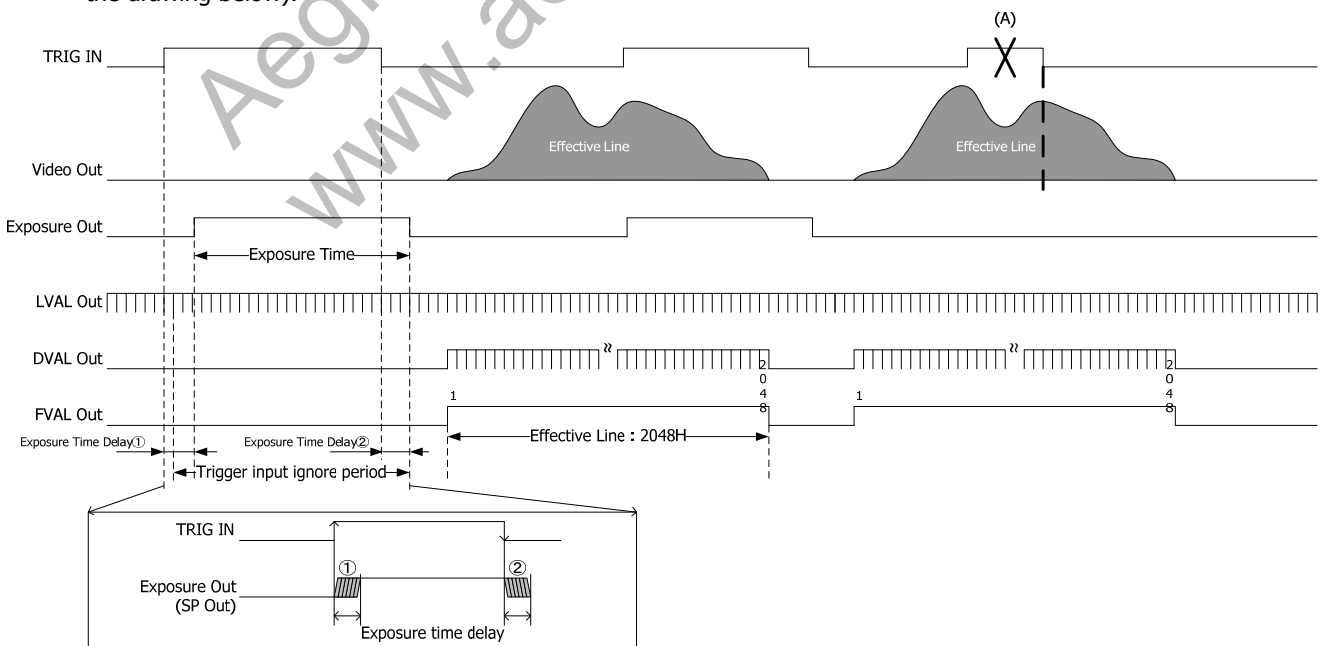

7.6. FAST Pulse Width Trigger Shutter Mode

- This is the mode to start exposure with external input trigger signals, and set the exposure time with pulse width of the trigger signals.
- Trigger operation is CLK Sync, and V-sync Restart system.
The delay time (Exposure Time Delay①) from detecting trigger edge in the camera to starting exposure is approx. $0.05 \mu s$. The delay time (Exposure Time Delay②) from detecting trigger edge in the camera to end exposure is approx. $13.73 \mu s$.
- Pulse width is min. $0.27 \mu s$ to approx 2 frames. Functionally, there is no upper limitation, but noises such as dark noises shadings may be noticeable at long time exposure.
- There is an exposure time period for approx. $13.73 \mu s$ at the edge right after exposure output.

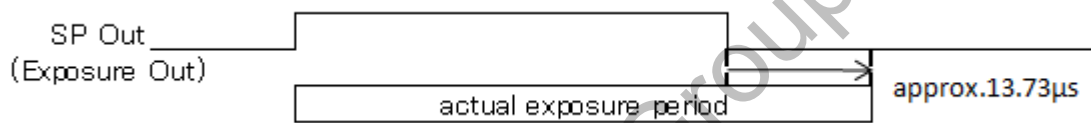

Trigger input during exposure time shall be ignored in the camera. (Refer to (A) in the drawing below).

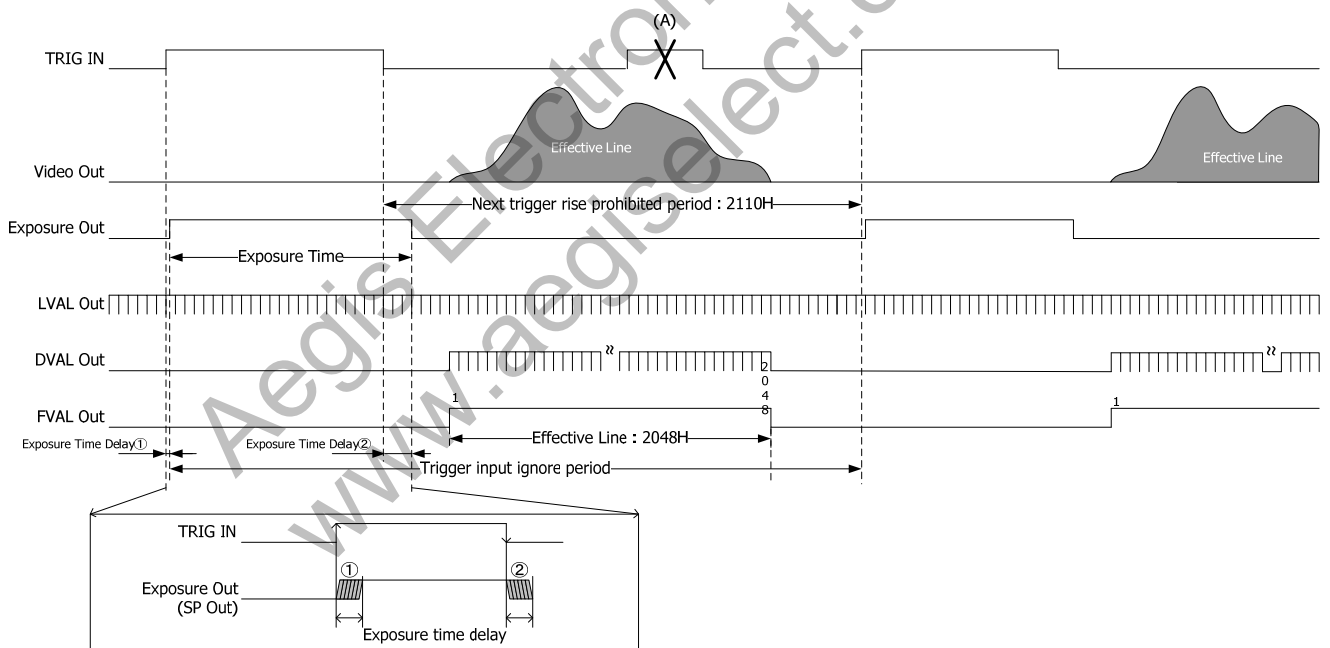

8. Partial Scan Mode

- Maximum 8 partial areas can be set by serial commands.

Example : 3 partial areas to be set.

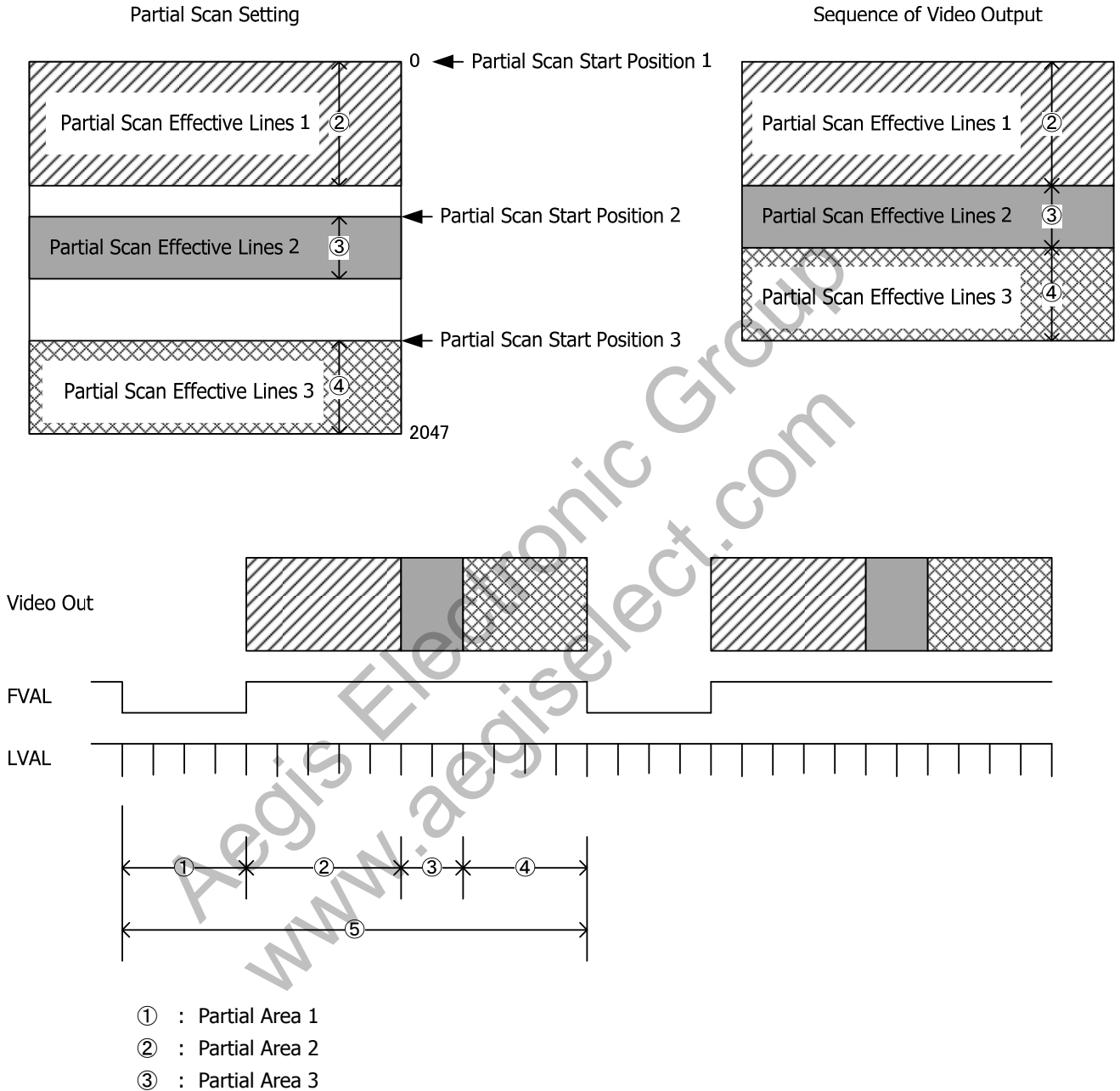

- When setting several partial scan areas, please set the start position and effective lines trying not to overlap the areas.
- When setting several areas, please set the areas in the numerical order of the start position.
- Total line count per frame = **V blanking lines** +
 Partial effective lines 1 + Partial effective lines 2 + ... + Partial effective lines 8

Note that Sum total of partial effective line numbers from 1~8 (except V blanking lines) has to be less than 2048.
 V blanking lines at partial mode is 46H.

- Frame rate = 1 / (Total line count per frame × Time for 1 line)

Time for 1 line

| Camera Mode | Time for 1 Line |
|-------------------------|-----------------|
| 10Tap8bit Configuration | 2.92 μs |

- ※ Frame rate with FAST trigger mode

$$\text{Frame rate} = 1 / (\text{Frame entire line number} \times \text{Time for 1 line} + \text{Exposure time})$$

- Setting Examples (At FAST trigger mode, the frame rates become different from the one of the chart below since overlapped operation is invalid at FAST trigger mode).

| | Effective Lines | Frame rate (Entire frame lines) | |
|---------------------------|-----------------|---------------------------------|------|
| | | 10tap8bit | |
| 4 (min) | 4 H | fps | (H) |
| . | . | 6843.3 | 50 |
| Vertical: VGA equivalent | 480 H | fps | (H) |
| . | . | 650.5 | 526 |
| Vertical: XGA equivalent | 768 H | fps | (H) |
| . | . | 420.4 | 814 |
| Vertical: SXGA equivalent | 1024 H | fps | (H) |
| . | . | 319.8 | 1070 |
| Vertical: UXGA equivalent | 1200 H | fps | (H) |
| . | . | 274.6 | 1246 |
| 2048 (max) | 2048 H | Fps | (H) |
| Full frame | | 163.4 | 2094 |

- The line numbers at partial scan setting can be set from 4 lines. Only multiple numbers of 4 can be set.
- The effective line numbers of the manual shutter setting value at partial scan setting become the maximum.
- When partial scan setting is set to ON or OFF, the coordinates of a cursor is reset to (0, 0).
- Changes to partial scan setting (Address 50) shall be done when partial scan setting is OFF.
- When you switch between Full Frame Scan Mode and Partial Scan Mode or when you change Partial scan settings, the first one frame right after the changes shall be invalid.

***Especially at fixed trigger shutter mode and pulse width trigger shutter mode, input a dummy trigger first, and use the next trigger as an actual video signal.**

9. Remote Communication Function

Via camera link serial communication function, the camera can be controlled.

(1) The settings for serial communication

| | |
|-----------|------------------------|
| Baud rate | 9,600bps or 115,200bps |
| Data | 8bit |
| Stop bit | 1bit |
| Parity | None |
| XON/XOFF | Not Controlled |

(2) Control Code

- The total control code conforms to ASCII code.
- A control code consists of command, parameter and CR (0Dh). The changes and acquisition of setting parameters can be done by issuing commands from PC.

| Command | Parameter 1 | Parameter 2~7 | Function |
|---------|-------------|---------------|----------------------------|
| GU | Address | Data 1 | Obtain setting information |
| SU | Address | Data | Change of camera settings |
| INIT | None | None | Restore factory settings |
| SAVE | None | None | Save the camera settings |
| GSI | 1 | None | Acquire its model name |

As for the address and the data, please refer to "5. Function settings".

(3) How to set a command

- Input a command in capital letters
- Separate between a command and a parameter by one space.
- From the head of input character to the linefeed code [¥r]or[¥n] is analyzed as one command.
- With 0x, the parameter shall be analyzed as hexadecimal number, and decimal number without 0x.
- The identifiable letters from the head are to be analyzed.
- The returned command from the PC will be received by the camera, and then echoed back.
- Refer to "Section 5. Function settings" for the address and data.
- Do not input values and letters other than the specified above command and those mentioned in "Section 5. Function settings"
- Do not issue the next command until the prompt which shows the completion of the prior command is shown.

(4) Setting Examples

【Example of Get Command】

To get the information of the address 21

[Send] GU[sp]21[¥r] or[¥n]

[Returned value] 50[¥r] [¥n]

[Returned value] [¥r] [¥n]

[Returned value] >[sp]

[Acquired data + Linefeed]

[Linefeed]

[Prompt + Space]

| |
|------------------|
| [¥r]=CR(0x0D) |
| [¥n]=LF(0x0A) |
| [sp]=Space(0x20) |

【Example of Set Command】

To set 30 to the address 21

[Send] SU[sp]21[sp]30[¥r]or[¥n]

[Returned value] [¥r] [¥n]

[Returned value] >[sp]

[Linefeed]

[Prompt + Space]

【Example of SAVE Command】

[Send] SAVE[¥r]or[¥n]
[Returned value] [¥r] [¥n] [Linefeed]
[Returned value] >[sp] [Prompt + Space]

(5) [¥r]or[¥n]

Make sure to input to indicate the end of the command.

(6) Initial settings

Input "INIT" to restore to the initial settings. (Not saved at this point).

(7) Data Save

Input "SAVE" to save the camera settings

[Returned value] [¥r] [¥n] [Linefeed]
[Returned value] >[sp] [Prompt + Space]

Aegis Electronic Group
www.aegiselect.com

10. Pixel Defect Correction

- This is the function to detect and correct the pixel defects in the data output from the sensor.
- Data are categorized into 2 types and controlled.
 - Data at Ex-Factory
The detected data of white pixel defects and black pixel defects at Ex-Factory are saved. Basically, these data cannot be erased.
 - Data the user registered
Data increased after shipment or the one registered by the user. These data can be erased anytime.
- Pixel defect correction data for normal mode and for vertical flip mode are saved separately. (Pixel defect position and number are different at normal mode and at vertical flip mode).
- The number of data registerable by users is 256. (Note: Up to 32 points per CH.)

「CH (Channel)」

Images are processed by 8ch interleave in the camera.

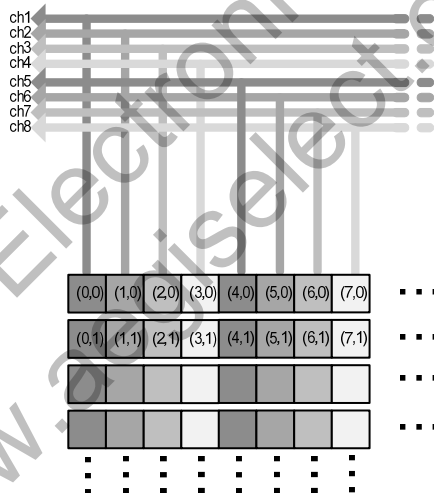

- The registerable number of pixel defects and the correctable number of pixel defects may not be always the same.
 - (1) With white defects detection, if one of the strip read reached the maximum number, correction could not be performed. In such case, the data up to that point are registered, error is output, and operation ends.
 - (2) If no effective pixel exists up next, down next, right next, or left next to the pixel to be corrected, this pixel can be registered but cannot be corrected.



For example, when X1, X2, X3, and X4 are already registered as defected pixels, X can be added to be registered but it cannot be corrected.

- White Defects Detection by the users. (Address 100).

This is the function to register the pixels automatically if a pixel exceeds the level specified by the user. Please be noted that no lights should be in the sensor surface to use this function.

There are 2 kinds of parameters for commands.

The First Parameter: Threshold (0~1023)

The data with luminance level more than the specified level here shall be registered.

※ In case of 8bit images, 4 times value of the image signal level shall be specified as the threshold value.

The Second Parameter: Additional Flag (0, 1)

When 0 is specified, all of user's white defects data registered by that time are cleared out, and data will be newly registered.

When 1 is specified, only newly detected white defects data will be added to the old data registered by that time.

- ◇ Even when the Additional Flag 0 is specified, the added data with the Address 101 would not be deleted.

- Additional registration of defected pixels by users (Address 101).

This is the function to register any defected pixels specifying its coordinate.

There are 2 parameters as commands.

The first parameter: X Coordinate

The second parameter: Y Coordinate

- ◇ When the same defected pixel as the one registered at our Ex-factory was specified, it shall be ignored.

- Deletion of defected pixels data registered by users (Address 102).

This is the function to delete the defected pixels data detected and registered by the users.

There are 2 parameters as commands.

The first parameter: X Coordinate

The second parameter: Y Coordinate

- ◇ Only the registered data by users, with Address 100 or Address 101, can be deleted. The data registered at our Ex-factory cannot be deleted by this command.

- Entire deletion of defected pixels data registered by users (Address 103).

This is to delete all defected pixels data detected and registered by the users, with Address 100 and Address 101.

Please execute this when you wish to redo your detection and registration from the beginning, or when you wish to restore all the registration to the factory settings. SU 103 1 to execute

- Indication of defected pixels (Address 104)

Operation when setting data and operation when acquiring data are different.

(1) When setting (SU 104)

This is the function to indicate the actually corrected pixels by that time, with 75% brightness.
On/Off is done by parameters.

Parameter 0: OFF
Parameter 1: ON

- ◇ Bright point indication function cannot be saved.

(2) When acquiring (GU 104)

This is the function to indicate the registered defected pixels.
3 kinds of lists can be indicated by parameters.

Parameter 1: Entire lists, both ex-factory data, and the added and registered data by the users, are shown.
Parameter 2: Only the list added and registered by the users is shown.

(Example of indication)

| | | |
|------|-----|---|
| 925 | 443 | W |
| 1228 | 460 | W |
| 1271 | 488 | W |
| 500 | 500 | P |
| 1098 | 520 | W |
| 930 | 629 | U |

From the left, X coordinate, Y coordinate, and the type of defects
[Type of defects]
W: White defects registered at Ex-factory
B: Black defects registered at Ex-factory
U: White defects registered by the user
P: Defects added by the user

Parameter 3: Indicates the number of the registered defected pixels per CH (Data at Ex-factory + Data registered by the user.)

Parameter 4: Indicates the number of the registered defected pixels per CH (Data registered by the user only.)

Please be noted the below and always check the status whenever you change the image indication size.

「Notes for coordinate indication」

- X coordinate and Y coordinate shown is the one for the current image. When vertical partial (SU50, 54), horizontal flip (SU11), or vertical flip (SU12) is changed, the coordinates to be indicated shall be changed accordingly.
- The lists shown by parameters 3 and 4 are only the registered data in the currently shown image area. (When indication image size was reduced, some registered data by the user could be out of area. In such case, the coordinate points out of the indication area would not be shown.)
- To show the coordinate points of out of the area, execute parameter 1 or parameter 2. These points would be shown as minus coordinate or as the one of the out of image size.

11. User Data SAVE/Read Out Function

This is the function for users to save any data with 32 byte (Address 0~31).

Set the data to the specified address with command and issue SAVE command to save user data. These data are not initialized by INIT command. For the details of protocol, please refer to the Section 9. Remote Communication Function.

11.1. SAVE User Data

There are two ways to write in the data.

Data shall be set per 1 byte (0~255 or 0x00~0xFF).

(1) Data writing with 1 Byte

【Send】 SU[sp]200[sp]Write Address[sp]Data
 【Returned value】[Yr][Yn]
 【Returned value】>[sp]

(2) Continuous data writing

The maximum 4 of 1 byte (0~255 or 0x00~0xFF) data can be set with space partitions.

If more numbers than the address were set, error would occur.

【Send】 SU[sp]200[sp]Write Address[sp]Data[sp]Data[sp]Data[sp]Data
 【Returned value】[Yr][Yn]
 【Returned value】>[sp]

11.2. Reading Out of User Data

Specify the address to be read out and the number of data to read out.

Data are shown with hexadecimal with space partitions.

When data count more than the address are specified, error would occur and it would not be read out.

【Send】 GU[sp]200[sp] Readout Address[sp]Read out Count
 【Returned value】 0xnn[sp]0xnn[sp]0xnn[sp][Yr][Yn]
 【Returned value】>[sp]

12. Factory Settings

| Function | Address | Data | |
|-------------------------------------|---------|------|--------------------------------|
| Trigger Shutter Mode | 3 | 0: | Normal shutter mode (Free-run) |
| Trigger Polarity | 4 | 0: | Positive |
| Trigger Input | 5 | 0: | Camera Link CC1 |
| FAST Trigger Mode Selection | 6 | 0: | H Sync mode |
| Test Pattern Output | 7 | 0: | OFF |
| Cursor Indication | 8 | 0: | OFF |
| Horizontal Flip of the Output Image | 11 | 0: | Normal |
| Vertical Flip of the Output Image | 12 | 0: | Normal |
| Defective Pixel Correction | 13 | 1: | ON |
| Serial Communication Baud Rate | 14 | 0: | 9600baud |
| Gain | 20 | 0: | 0dB |
| Shutter | 23 | 0: | OFF |
| Vertical Partial Mode | 54 | 0: | OFF (2048line) |

Factory setting for rear switch

| | | |
|-----------------|-----|---------|
| Power Selection | SW1 | CL side |
|-----------------|-----|---------|

13. Sensor Optical Axis Accuracy

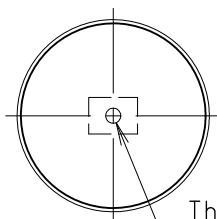
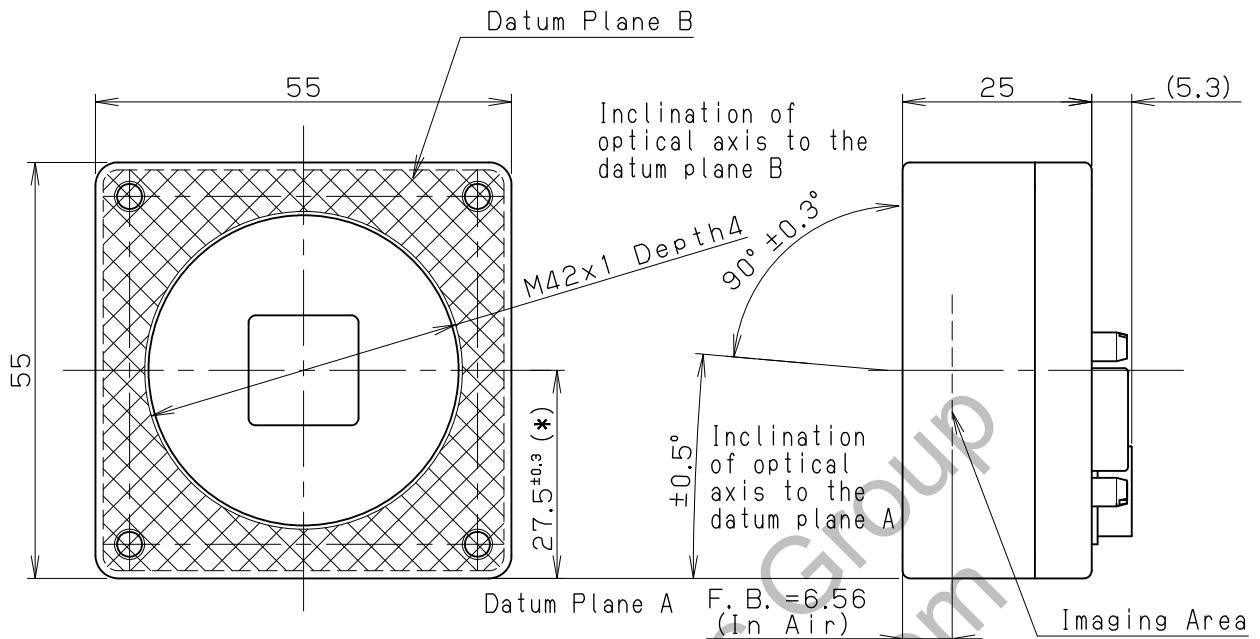

The center of the effective pixels shall be within 0.6 to the center of the lens mount.

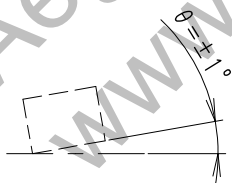

Inclination of the effective pixels θ to the datum plane is $\theta \leq \pm 1^\circ$.

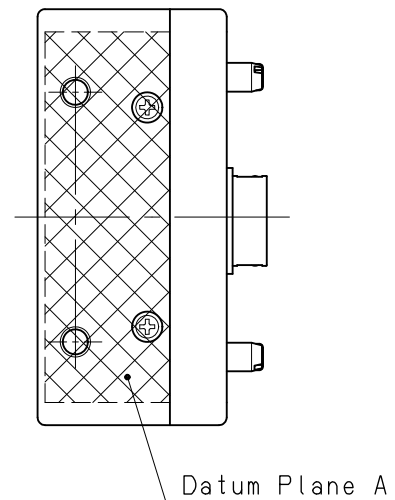

*) Dimensions from the datum plane A to the center of the lens Mount

910-017-00
(Unit : mm)

14. Dimensions

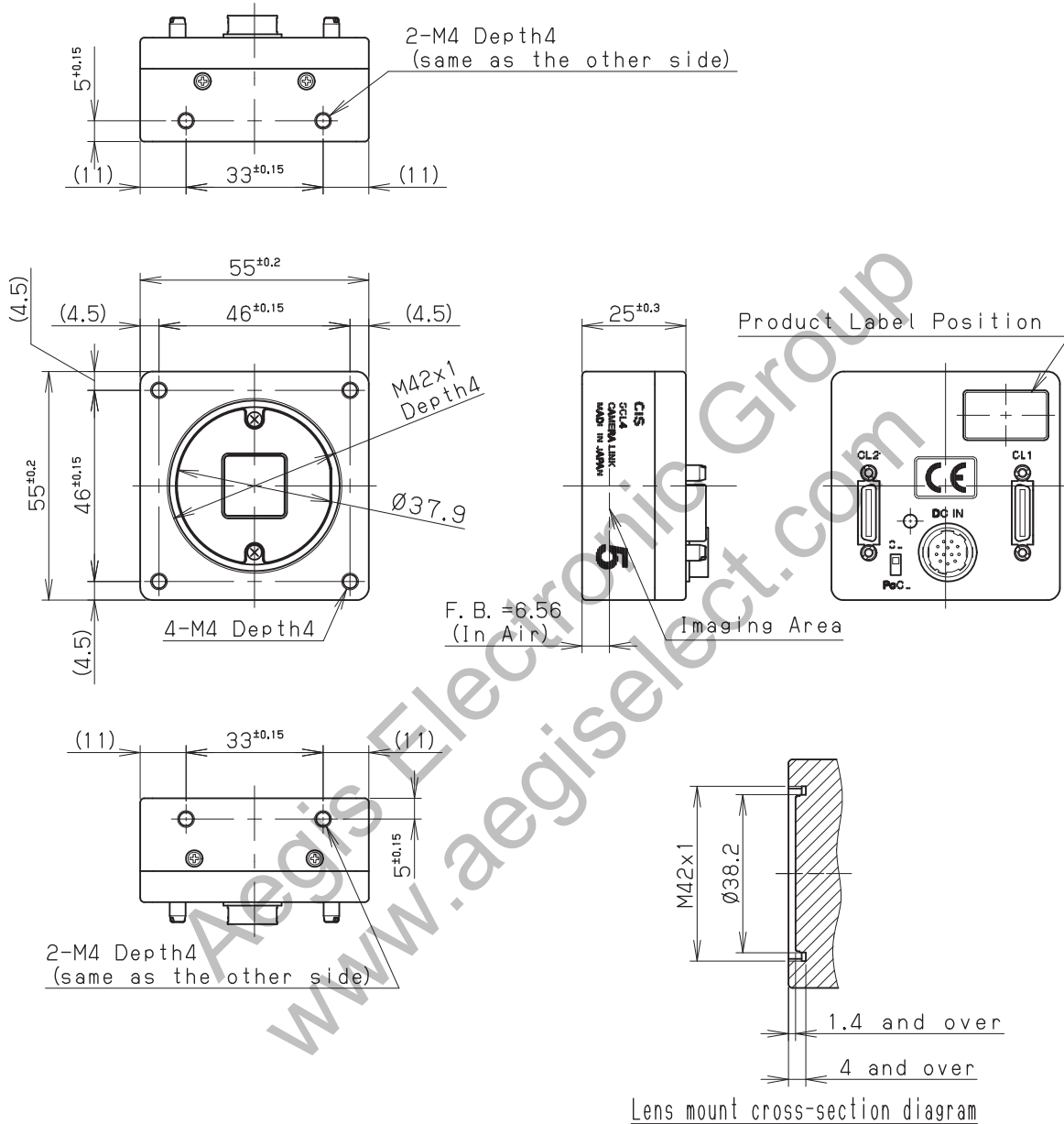

Note 2) Lens mount screw complies with M42x1.0-6H. Please refer to ISO 68-1, 965-1 (or JIS B0205-1, B0209-1).

Note 1) Please make sure the protrusion portion does not interfere with the lens selected. Refer to the Lens mount cross-section diagram for the details.

935-067-00
(单位: mm)

15. Case for Indemnity (Limited Warranty)

The term of warranty of this product is within 3 years from the date of shipping out from our factory. If you use the product properly and discover a defect during the warranty period, and if that was caused by designing or manufacturing, CIS Corporation, at its option, repairs or replaces it at no charge to you. Products out of warranty period will be subject to charge. CIS repairs the products as long as it is repairable.

CIS shall be exempted from taking responsibility and held harmless for damages or losses incurred by the following cases.

- In case damages or losses are caused by earthquake, lightning strike, fire, or other acts of God.
- In case damages or losses are caused by deliberate or accidental misuse by the user, or failure to observe the information contained in the instructions in this Product Specification and Operational Manual.
- In case damages or losses are caused by repair or modification conducted by the customer or any unauthorized party.

16. CMOS Pixel Defect

CIS compensates the noticeable CMOS pixel defects found at the shipping inspection prior to our shipment. On very rare occasions, however, CMOS pixel defects might be noted with time of usage of the products. Cause of the CMOS pixel defect is the characteristic phenomenon of CMOS sensor itself and CIS is exempted from taking any responsibilities for them. Should you have any questions on CMOS pixel defects compensation please contact us.

17. Product Support

Should you have any problems in function of the product you purchased, and if you need our further analysis and/or repair, please contact the dealer you purchased it from.

18. Ordering Information

| Model Name | Baud Rate (bps) |
|---------------|-----------------|
| VCC-5CL4MHS-1 | 115,200 |

19. Licensing

This camera utilizes μ T-Kernel source code in accordance with μ T-License of T-Engine forum (www.t-engine.org).