

CIS

CMOS MV Cameras

VCC-3CL5M/R

Product Specifications
& Operational Manual

CIS Corporation

Table of Contents

	Page
1. Handling Precautions	3
1.1. Camera Handling Precautions	3
1.2. Restrictions on Applications	3
1.3. Disclaimers (exception clause)	3
1.4. Precautions on Exporting	3
2. Product Outline	4
2.1. Features	4
2.2. System Configuration	4
3. Specifications	5
3.1. General Specifications	5
3.2. Part Names and Functions	7
3.3. CMOS Spectral Response	9
3.4. Output Data Configuration	10
4. Remote Communication	11
4.1. Serial Communication Specifications	11
4.2. Function Settings	13
5. Details on Function Settings	15
5.1. Shutter Mode	15
5.2. Shutter Time	17
5.3. White Balance Function	18
5.4. ROI Function	20
5.5. White Defect Pixel Correction	22
6. Dimensions	23
6.1. Camera Outline Drawing	23
6.2. Sensor Optical Axis Accuracy	24
7. Case for Indemnity (Limited Warranty)	25
7.1. Product Warranty	25
7.2. CMOS Pixel Defect	25
8. Supplementary Note	25
8.1. Product Support	25
8.2. Ordering Information	25

1. Handling Precautions

1.1. Camera Handling Precautions

- Do not apply excessive force or static electricity that could damage the camera. Handle the camera with care.
- Do not use or store the camera in the extremely dusty or humid places.
- Do not shoot direct images that are extremely bright (e.g., strong light source, sun, etc.). When strong light such as spot light was shed, blooming or smear may occur. Put the C mount lens cap on when camera is not in use.
- Confirm the mutual ground potential carefully before connecting the camera to monitors or computers. Any AC leaks or coupling noises from the connected devices may cause damages or destroy the camera.
- When mounting the camera to a seating base or others, please be careful not to make the lens contact the base. And refer to the camera drawings and note the restrictions on screws to be used.
- When attaching a lens to the camera, remove the C mount lens cap right before installation to avoid dust on the sensor.
- Follow the Industrial Wastes disposal methods and rules in accordance with the laws and regulations of respective countries and municipalities.
- 5 seconds shall be waited after power is turned ON to operate the camera properly.

1.2. Restrictions on Applications

- The camera must not be used for any nuclear equipment or aerospace equipment with which mechanical failure or malfunction could result in serious bodily injury or loss of human life. Our warranty does not apply to damages or defects caused by irregular and/or abnormal use of the product.
- The camera must not be used under conditions or environments other than specified in this manual.

1.3. Disclaimers (exception clause)

CIS shall be exempted from taking responsibility and held harmless for damages or losses incurred by the following cases.

- In case damages or losses are caused by earthquake, lightning strike, fire, flood disaster, or other acts of God.
- In case damages or losses are caused by deliberate or accidental misuse by the user, or failure to observe the information contained in the instructions in this Product Specification and Operational Manual.
- In case damages or losses are caused by repair or modification conducted by the customer or any unauthorized party.
- CIS compensates the noticeable CMOS pixel defects found at the shipping inspection prior to our shipment. On very rare occasions, however, CMOS pixel defects might be noted with time of usage of the products. Cause of the CMOS pixel defect is the characteristic phenomenon of CMOS sensor itself and CIS is exempted from taking any responsibilities for them.

1.4. Precautions on Exporting

- When exporting our products, fully follow administrative regulations, such as "Export Trade Control Order", "Foreign Exchange Control Order", and "Catch-All Controls", and carefully research on your end customer and its applications to classify and determine if it is appropriate to export.

※ Refer to the METI web (Ministry of Economy, Trade and Industry) for the details.

<http://www.meti.go.jp/policy/anpo/englishpage.html>

2. Product Outline

VCC-3CL5M and VCC-3CL5R are Camera Link interfaced, and 3M resolution industrial camera modules. 3M pixels, 1/1.8 type CMOS sensor is utilized. Entire pixels (2064x1544) can be read out at 55fps (at 3TAP output). 29mm cubic in size with 3M resolution, yet cost effective cameras.

2.1. Features

- Camera settings can be set via serial command communications from the host equipment.
- Global trigger shutter operation.
- Output bit length can be set, and output tap is selectable out of 1tap, 2tap, and 3 tap.
- ROI function
- Sub-sampling function
- Generates HV cross line signals
- 29mm cubic in size

2.2. System Configuration

- Camera
 - Camera
VCC-3CL5M or VCC-3CL5R (with seal-type C mount lens cap for image sensor protection)
- Packaging
 - Individual Carton
 - Master Carton (20pcs/carton)

Note) Master carton may vary depends on the quantity to be shipped.
- Free Software
 - CIS control panel software for evaluation purpose only is downloadable via our web.
CIS shall be exempted from taking responsibility and held harmless for damages or malfunction of your hardware and software caused by using this control software. The purpose of this control software prepared is for users to check operation and evaluate our products. Please be noted that CIS does not customize the program nor provide source code.

3. Specifications

3.1. General Specifications

Electrical Specifications	
(1) Pick up device	Device Type 1/1.8 type 3M pixels, Global shutter type CMOS sensor Effective pixel number 2064(H) x 1544(V) Unit cell size 3.45 μ m x 3.45 μ m Chip size Diagonal length 8.9mm
(2) Interface	Camera standard PoCL/non-PoCL Base Configuration Model Camera Link Version 1.2 complied Video output digital 8/10/12bit (1Tap, 2Tap), 8bit (3Tap) Mono/Raw Output data clock 74.25MHz
(3) Frame rate	Full Frame 55.69fps (3Tap), 45.48fps (2Tap), 22.78fps (1Tap)
(4) Effective video output	The maximum 2064(H) x 1544(V)
(5) Sensitivity	F5.6 400 lx 45fps (VCC-3CL5M) F5.6 2000 lx 45fps (VCC-3CL5R)
(6) Minimum illumination	F1.4 0.2 lx 45fps (VCC-3CL5M) F1.4 2.0 lx 45fps (VCC-3CL5R)
(7) Camera operational mode	Continuous read-out shutter operation Pre-set trigger shutter operation Pulse width trigger shutter operation
(8) Gain control Preset Manual	12 patterns x1 ~ x128 (0dB ~ 42dB) x1: 0 ~ x128: 420 (0dB ~ 42dB) 0.1dB step
(9) Shutter time Preset Manual	Continuous 11 patterns off ~ 1/17500s (2tap) Trigger (Preset) 12 patterns 1/30s ~ 1/50000s Continuous 1/30s ~ 1/17500s (2tap) Preset/Pulse Width Trigger 6 μ s ~ 200ms
(10) White balance WB Mode Manual	(VCC-3CL5R) Through / One push / Manual R/G gain 0 ~ 400% Color temperature range 2700K ~ 10000K
(11) ROI function Preset Manual	Center area 6 patterns Column Width Range: 264 ~ 2064 multiples of 12 Row Height Range: 8 ~ 1544 multiples of 4
(12) Sub-sampling	(VCC-3CL5M) OFF/ON x and y, 1 read and 1 skip
(13) Serial communication settings	System RS232c complied Baud rate 9600, 115200 bps
(14) Power requirements	DC 12V (10.5 ~ 15V Power IN terminal, 10.5V ~ 13V Digital I/F terminal)
(15) Power consumptions	1.9W

Mechanical Specifications	
(16) Dimensions	29(H) x 29(W) x 29(D) mm (without protruding portion)
(17) Weight	45g
(18) Lens mount	C-mount flange back: 17.526mm
(19) Optical axis accuracy	HV direction positioning accuracy: within $\phi 0.6\text{mm}$ HV direction rotation accuracy: $\pm 0.5^\circ$ Decline accuracy to the base surface: $\pm 0.2^\circ$
Environmental Specifications	
(20) Safety/Quality Standard	RoHS2 Conform to 2011/65/EU CE: EMC (Electro Magnetic Compatibility) 1)EMI (Electro Magnetic Interference) EN55022:2010 (Class A) 2)EMS (Electro Magnetic Susceptibility) EN61000-6-2:2010 KC: R-R-cIs-VCC-3CL5M ※The final judgment for EMC shall be complied as a whole system.
(21) Durability	Vibration ICE 60068-2-6 complied Acceleration : 98m/s^2 (10G) Frequency : 20 ~ 500 Hz, 1min/oct Direction : X, Y, and Z 3 directions Testing time : 120min for each direction
	Shock IEC 60068-2-27 complied Level : 980m/s^2 (100G) Direction : $\pm X$, $\pm Y$, and $\pm Z$ 6 directions
(22) Packaging	Drop impact IEC 60068-2-31 complied Height : 60cm Number of times : 1 time/6 sides
(23) Operational environment	Temperature: $-5 \sim 45^\circ\text{C}$ Humidity: 20 ~ 60%RH with no condensation
(24) Storage Environment	Temperature: $-25 \sim 60^\circ\text{C}$ Humidity: 20 ~ 80%RH with no condensation

3.2. Part Names and Functions

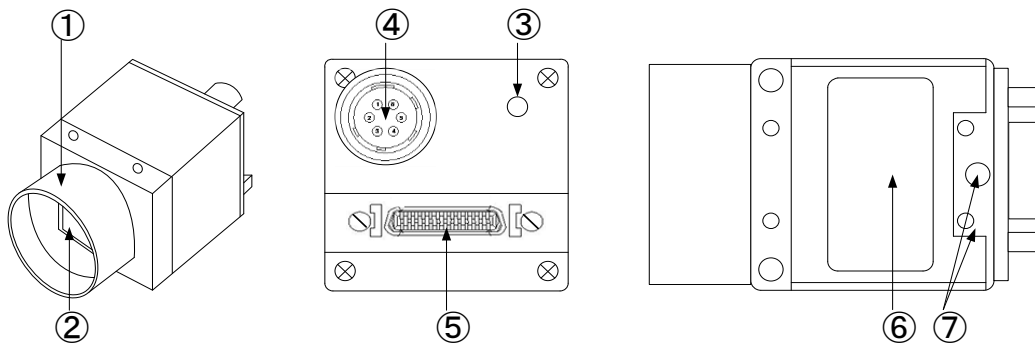

① Lens holder

To mount a C mount lens.

Screw length from the lens mount surface shall be less than 6mm. And protruding portion of the lens shall be less than 10mm.

② Image sensor / Optical filter

CMOS image sensor surface.

A dummy glass is attached on the surface of the sensor (VCC-3CL5M).

③ Status LED

The LED lights when the camera is connected and power is turned ON.

④ 6pins circular connector for external control

This is the connector to be used for trigger shutter operation or to supply power other than PoCL connector.

Usually, power is supplied via PoCL port, but this can be used when power is not enough or when you cannot supply power from others. Trigger IN signal is electrically insulated.

Never supply power via both 6pins circular connector and camera link connector at the same time.

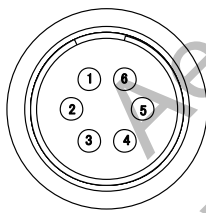

HR10A-7R-6PB
or equivalent
(HIROSE)

Pin No.	Signal Name	Description
1	Power IN	non-PoCL: Power Input (DC 12V typical)
2	NC	Not used
3	EEN OUT	Exposure Enable Output (Open Collector)
4	Trigger IN-	Trigger Input- (Isolated)
5	Trigger IN+	Trigger Input+ (Isolated)
6	GND	GND (for Pin 1)

Input/Output circuit for external control

Trigger IN terminal (TRIG_IN in the drawing) shall be capable of 10mA ~ 20mA.

And, 0.5mA ~ 5mA shall be added to EEN OUT terminal (EEN_OUT in the drawing) as load resistance for power (3.3V ~ 20V).

Example

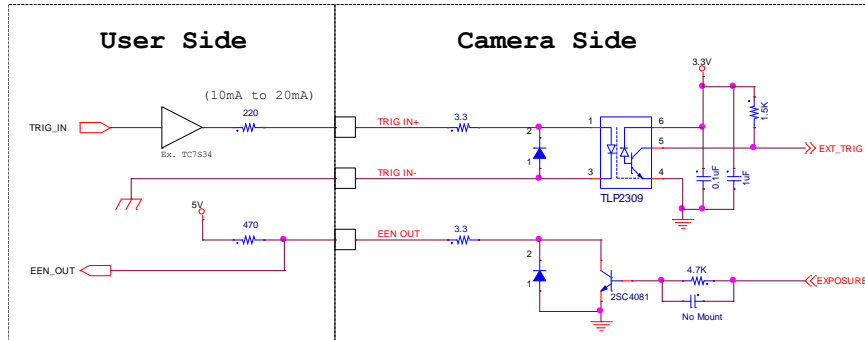

⑤ Auto selection of Camera Link connector PoCL/non-PoCL

This is the Camera Link connector for video signals/camera control.

Cables to be used varies depending on the conditions of the board to be connected.

For PoCL connection, pin number 1 and 26 are for power, so that a PoCL cable must be used.

For non-PoCL connection, pin number 1 and 26 are for GND, so that non-PoCL cable must be used.

Never supply power via both 6pins circular connector and camera link connector at the same time.

Camera Link Base Configuration
PoCL/non-PoCL

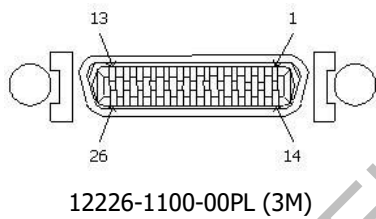

Pin No.	Signal Name	Description
1,26	Power IN or GND	PoCL : DC 12V Power Input non-PoCL: GND
13,14	GND	GND
2,15	X0-, X0+	X0_OUT0 differential pair for transmission
3,16	X1-, X1+	X1_OUT1 differential pair for transmission
4,17	X2-, X2+	X2_OUT2 differential pair for transmission
5,18	Xclk-, Xclk+	CLK OUT differential pair for transmission
6,19	X3-, X3+	X3_OUT3 differential pair for transmission
7,20	SerTC+, SerTC-	RXD Input differential pair for reception
8,21	SerTFC-, SerTFC+	TXD Output differential pair for transmission
9,22	CC1-, CC1+	Trigger Input differential pair for reception
10,23	CC2+, CC2-	Reserve differential pair for reception
11,24	CC3-, CC3+	Not used
12,25	CC4+, CC4-	Not used

⑥ Product Name Plate

When you need to contact CIS for analysis or questions, please let us know of its model name and serial number on the product name plate.

⑦ Screw holes for camera installation

Screw holes to attach the camera. M3 (Depth 3) x 3, M2 (Depth 3) x 6

3.3. CMOS Spectral Response

VCC-3CL5M mono

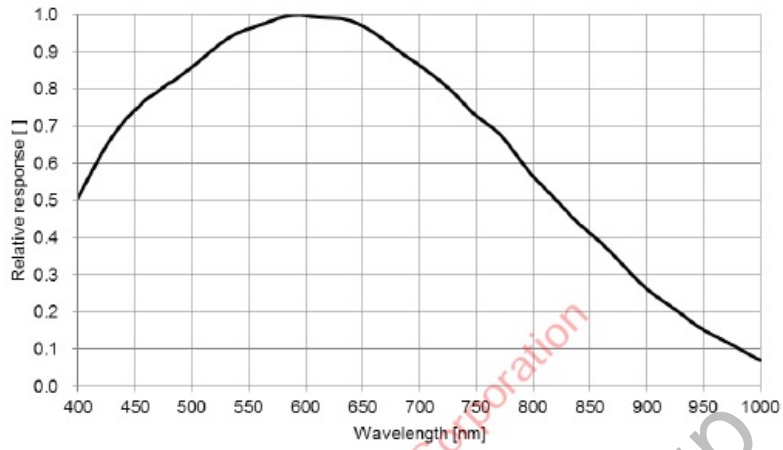

VCC-3CL5R color

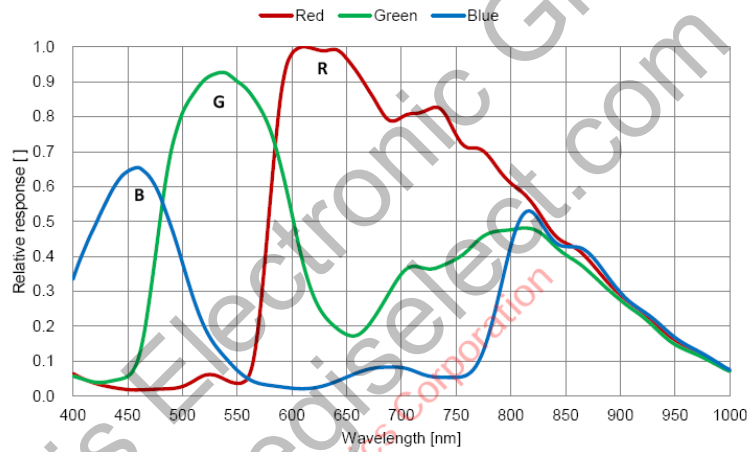

3.4. Output Data Configuration
Port Allocation

Port	8bit Output 1~3Tap	10bit Output 1~2Tap	12bit Output 1~2Tap
Port A0	DA[0] LSB	DA[0] LSB	DA[0] LSB
Port A1	DA[1]	DA[1]	DA[1]
Port A2	DA[2]	DA[2]	DA[2]
Port A3	DA[3]	DA[3]	DA[3]
Port A4	DA[4]	DA[4]	DA[4]
Port A5	DA[5]	DA[5]	DA[5]
Port A6	DA[6]	DA[6]	DA[6]
Port A7	DA[7] MSB	DA[7]	DA[7]
Port B0	DB[0] LSB	DA[8]	DA[8]
Port B1	DB[1]	DA[9] MSB	DA[9] MSB
Port B2	DB[2]		DA[10]
Port B3	DB[3]		DA[11]
Port B4	DB[4]	DB[8]	DB[8]
Port B5	DB[5]	DB[9] MSB	DB[9]
Port B6	DB[6]		DB[10]
Port B7	DB[7] MSB		DB[11] MSB
Port C0	DC[0] LSB	DB[0] LSB	DB[0] LSB
Port C1	DC[1]	DB[1]	DB[1]
Port C2	DC[2]	DB[2]	DB[2]
Port C3	DC[3]	DB[3]	DB[3]
Port C4	DC[4]	DB[4]	DB[4]
Port C5	DC[5]	DB[5]	DB[5]
Port C6	DC[6]	DB[6]	DB[6]
Port C7	DC[7] MSB	DB[7]	DB[7]

Output Data Array

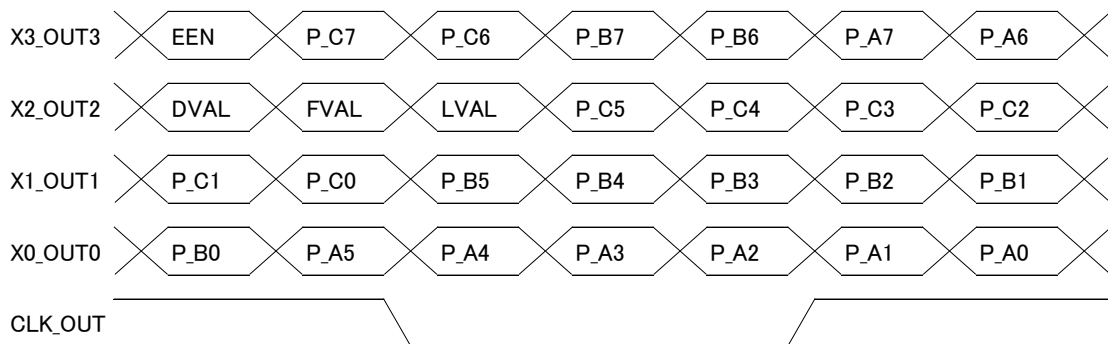

4. Remote Communication

4.1. Serial Communication Specifications

The camera can be controlled via serial port of Camera Link connector.

(1) Serial communication settings

Baud Rate:	9600/115200bps	default: 9600bps
Data bit:	8bit	
Stop Bit:	1bit	
Parity Bit:	not used	
XON/XOFF:	not used	

(2) Control code

- The total control code conforms to ASCII code.
A control code consists of command, parameter, and CR (0x0d). The changes and acquisition of setting parameters can be done by issuing commands from the host PC.

Command	Parameter 1	Parameter 2~7	Function
GU	Address	not used	Obtain setting information
SU	Address	Data	Change of camera settings
INIT	not used	not used	Restore to factory settings
SAVE	not used	not used	Save the camera settings
GSI	not used	Data	Camera information Data 1: Model name
GVI	not used	Data	Camera Version information Data 1: Micon Firm Version 2: FPGA HDL Version

(3) How to set a command

(4) {Command Name} {Parameter 1} {Parameter 2} {Parameter 3}...

- Input a command in capital letters.
- Maximum number of input character is 80.
- Separate between a command and a parameter by one space.
- From the head of input character to the linefeed code CR (0x0d) is analyzed as one command.
- Please refer to the [Section 4.2, Function Settings](#), for the details of address and data settings.
- Input of {Parameter n}
 - In case of Hexadecimal number:
Start from "0x" or "0X"
Either capital letters or lower case can be input. (a~f, A~F are both acceptable).
Input range: 0x0000~0xFFFF
 - In case of Decimal number:
Only '0'~'9' are acceptable.
Input range: 0~65535

【Example of Get Command】

To acquire information on the command number 10

[Send]	GU[sp]10[¥r] or[¥n]	
[Returned Value]	50[¥r] [¥n]	[Acquired data + Line feed]
[Returned Value]	[¥r] [¥n]	[Line feed]
[Returned Value]	>[sp]	[Prompt + Space]

【Example of Set Command】

To set 30 to the command number 10

[Send]	SU[sp]10[sp]30[¥r]or[¥n]	
[Returned Value]	[¥r] [¥n]	[Line feed]
[Returned Value]	>[sp]	[Prompt + Space]

【Example of SAVE Command】

[Send]	SAVE[¥r]or[¥n]	
[Returned Value]	[¥r] [¥n]	[Line feed]
[Returned Value]	>[sp]	[Prompt + Space]

[¥r]=CR(0x0D)

[¥n]=LF(0x0A)

[sp]=Space(0x20)

Aegis Electronic Group
www.aegiselect.com

4.2. Function Settings

Function	Address	Data	Description
(1) Output length and Tap width	2	0	3Tap 8bit Output
		1	2Tap 8bit Output (default)
		2	2Tap 10bit Output
		3	2Tap 12bit Output
		4	1Tap 8bit Output
		5	1Tap 10bit output
		6	1Tap 12bit Output
(2) Shutter mode	3	0	Continuous ShutterMode (default)
		1	Preset Trigger Shutter Mode
		2	Pulse Width Control Trigger Shutter Mode
(3) Trigger input settings	4	0	Camera Link CC1 Side , Positive Edge (default)
		1	Camera Link CC1 Side , Negative Edge
		2	6pin Connector Trig + , Positive Edge
		3	6pin Connector Trig + , Negative Edge
		4	6pin Connector Trig - , Positive Edge
		5	6pin Connector Trig - , Negative Edge
(4) Black level	7	0 ~ 255	Black level: 8 /8bit output default: 128 32 /10bit output 128 /12bit output 1 step by 12bit
(5) Flip function	11	0	Horizontal Reverse off (default)
		1	Horizontal Reverse on
	12	0	Vertical Reverse off (default)
		1	Vertical Reverse on
(6) Serial communication baud rate	14	0	9600bps (default)
		4	115200bps
			Baud rate settings shall be reflected after SAVE is executed and power is reboot
(7) Test pattern output	16	0	off (default)
		1	Gray scale (3CL5M). Color bar (3CL5R)
		2	HV Cross Line
(8) EEN output settings	17	0	Positive logic (default)
		1	Negative logic EEN output is valid only with trigger operation
(9) Gain control mode	20	0	Preset Gain 0dB x1 time (default)
		1	Preset Gain 3.5dB x1.5 times
		2	Preset Gain 6dB x2 times
		3	Preset Gain 9.5dB x3 times
		4	Preset Gain 12dB x4 times
		5	Preset Gain 15.5dB x6 times
		6	Preset Gain 18dB x8 times
		7	Preset Gain 21.5dB x12 times
		8	Preset Gain 24dB x16 times
		9	Preset Gain 30dB x32 times
		10	Preset Gain 36dB x64 times
		11	Preset Gain 42dB x128 times
15	Manual Gain Control Setting value of the Address 21		

Function	Address	Data	Description
(10) Manual gain control setting values	21	0 ~ 420	0dB ~ 42dB 0.1dB step default: 0 x16 times (24dB) and under is recommended to use because noises are less noticeable.
(11) Shutter time	23 ~ 24	0 ~ 15	Please refer to the Section 5. Details on Function settings , for the details of shutter time.
(12) White balance mode (Valid only for VCC-3CL5R)	30	0 1 2	Through mode (default) (Rgain= Ggain=Bgain) One Push White Balance mode Setting with the Address 34 Manual White Balance mode Setting with Address 31 and 33
(13) Manual white balance (Valid only for VCC-3CL5R)	31 33	0 ~ 400 0 ~ 400	Red gain 0 ~ 400% default: 100 Blue gain 0 ~ 400% default: 100 Please refer to the Section 5. Details on Function settings , for the details.
(14) One push switch (Valid only for VCC-3CL5R)	34	1	One Push Trigger
(15) ROI function	50 ~ 54	0 ~ 15	Please refer to the Section 5. Details on Function settings , for the details of ROI function.
(16) Sub-sampling function (Valid only for VCC-3CL5M)	56	0 1	off (default) on Hx2/Vx2 Sub-sampling 1032(H) x 772(V) 3tap: 108.62fps, 2tap: 88.70fps, 1tap: 44.44fps 1V = 808 lines, Cannot be used with ROI at the same time.
(17) Defective pixel correction			Please refer to the Section 5. Details on Function settings , for defect pixel correction function.

5. Details on Function Settings

5.1. Shutter Mode

Continuous readout shutter operation Continuous Shutter Mode

- This is the mode to read out video data continuously. Exposure time overlaps the readout period.
- No external trigger input signals are needed but it does free run.
- Shutter time is the preset shutter time set in advance.

When read out cycle changes by ROI function, faster shutter time than the read out cycle must be set.

Horizontal Timing at Full Scan (Reference)

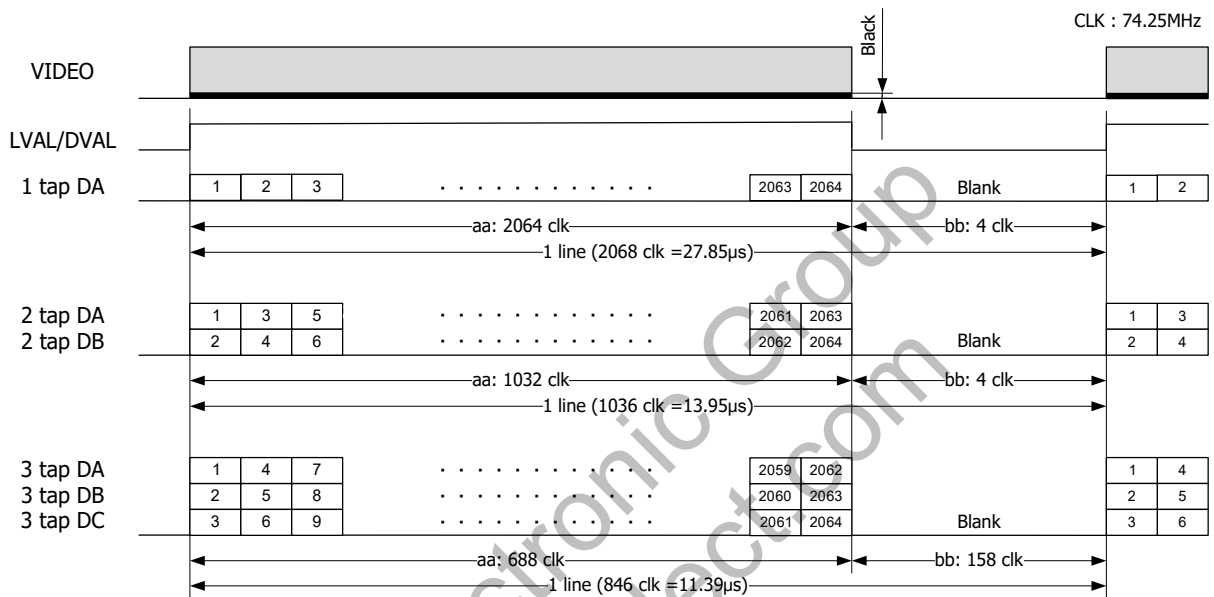

Vertical Timing at Full Scan (Reference for continuous read operation)

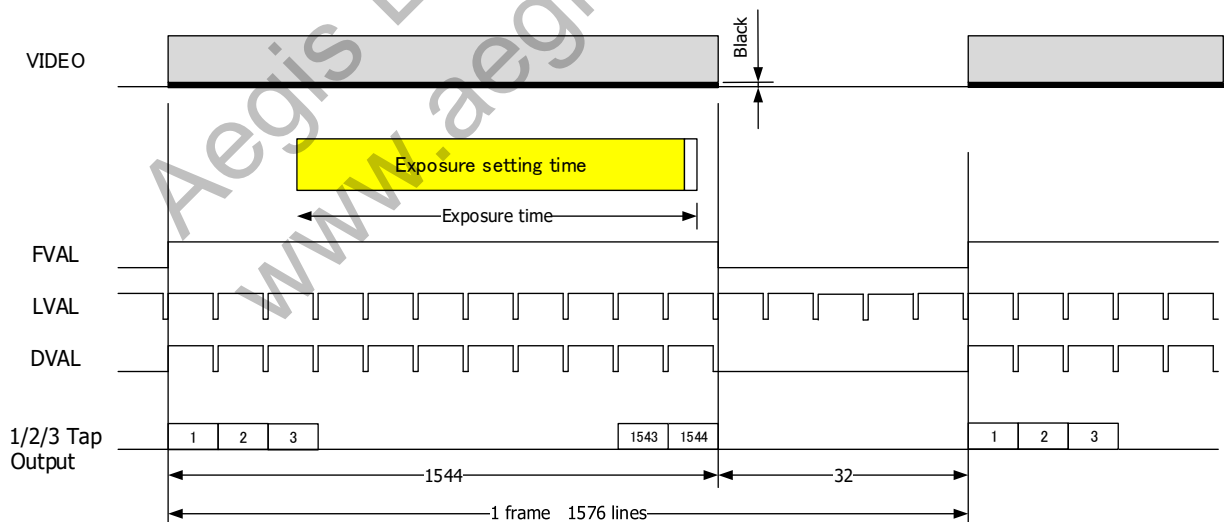

Preset trigger shutter operation Preset Trigger Shutter Mode

- This is to detect trigger pulse edge of external input, and readout an image after the completion of exposure period.
- Shutter time for exposure period shall be the preset shutter time set in advance.

Pulse width trigger shutter operation Pulse Width Control Trigger Shutter Mode

- This is to detect trigger pulse edge of external input, and readout an image after the completion of exposure period.
- Shutter time for exposure period is equal to the pulse width of trigger input signal.

Formula for the shutter time to be read out at Trigger Shutter Mode

This formula is common to 3tap, 2tap, and 1tap.

$$\text{Preset Trigger Shutter time} = (\text{Setting Value}) + 14\mu\text{s}$$

$$\text{Pulse Width Trigger Shutter time} = (\text{Trigger pulse width}) + 14\mu\text{s}$$

Formula for the shortest trigger input cycle (including ROI function) to be read out at Trigger Shutter Mode

3tap Shortest Interval on Trigger input = (Shutter time) + ((Active Vline) + 33) x 1line: 11.39μs

2tap Shortest Interval on Trigger input = (shutter time) + ((Active Vline) + 33) x 1line: 13.95μs

1tap Shortest Interval on Trigger input = (Shutter time) + ((Active Vline) + 33) x 1line: 27.85μs

Trigger Shutter Operation at Full Scan (Reference)

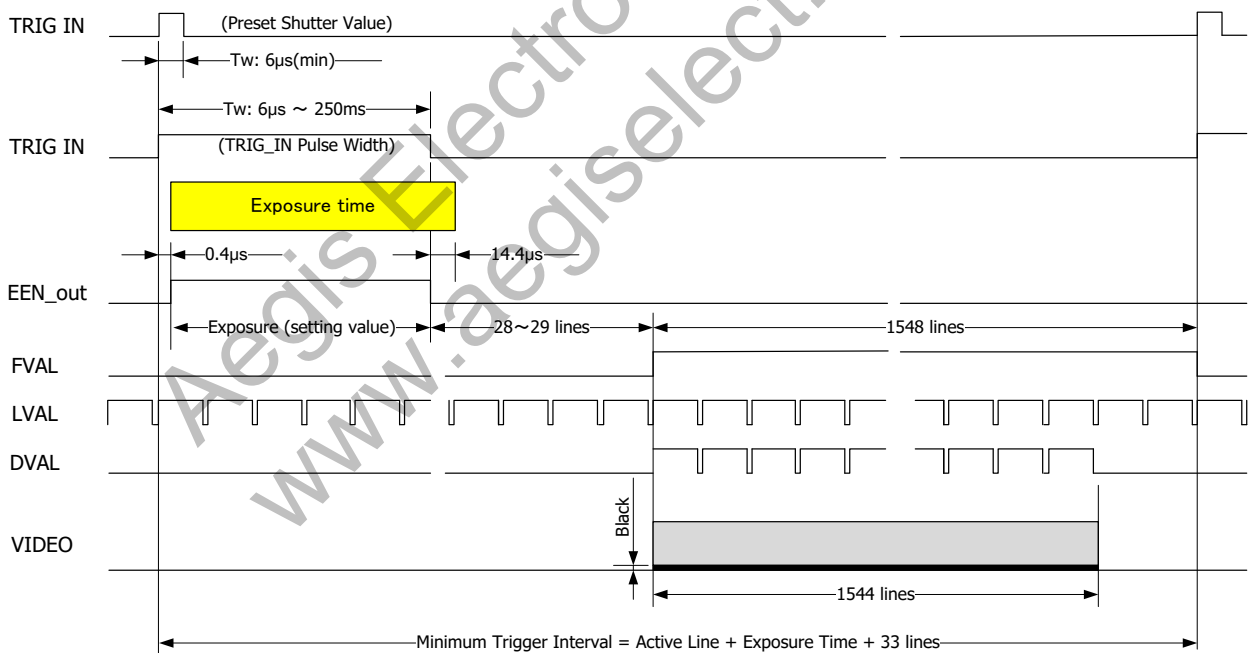

5.2. Shutter Time

Preset shutter time (Continuous Shutter Mode)

Address	Data	Description					
		3 tap		2 tap		1 tap	
		Shutter	Time	Shutter	Time	Shutter	Time
23	0 (off)	1/56s	17.8ms	1/45s	21.8ms	1/23s	43.6ms
	1	1/75s	13.6ms	1/60s	16.7ms	1/30s	33.3ms
	2	1/125s	8.17ms	1/100s	10.0ms	1/50s	20.0ms
	3	1/200s	5.45ms	1/150s	6.67ms	1/75s	13.3ms
	4	1/370s	2.72ms	1/300s	3.33ms	1/150s	6.64ms
	5	1/750s	1.36ms	1/600s	1.66ms	1/300s	3.30ms
	6	1/1500s	652μs	1/1250s	795μs	1/650s	1.57ms
	7	1/3000s	333μs	1/2500s	405μs	1/1250s	794μs
	8	1/6000s	162μs	1/5000s	195μs	1/2500s	376μs
	9	1/12500s	82μs	1/10000s	98μs	1/5500s	181μs
	10	1/20000s	48μs	1/17500s	56μs	1/10000s	98μs
	15	Manual Shutter as Continuous mode Setting value with the Address 24.					

Preset shutter time (Preset Trigger Shutter Mode)

Address	Data	Description	
		Shutter	Time
23	0	1tap/2tap/3tap	33330μs
	1	1/30s	16670μs
	2	1/60s	10000μs
	3	1/100s	6670μs
	4	1/150s	3330μs
	5	1/300s	1670μs
	6	1/600s	800μs
	7	1/1250s	400μs
	8	1/2500s	200μs
	9	1/5000s	100μs
	10	1/10000s	50μs
	11	1/20000s	20μs
	15	Manual Shutter as Preset Trigger mode Setting value with the Address 24.	

Manual shutter time setting values

Address	Data	Description
24	12bit	Continuous shutter mode Setting range = (Total line) – 2 line step Shutter_time_3tap (μ s) = (Setting value) x 1line: 11.39 μ s + 13.7 μ s Shutter_time_2tap (μ s) = (Setting value) x 1line: 13.95 μ s + 13.7 μ s Shutter_time_1tap (μ s) = (Setting value) x 1line: 27.85 μ s + 13.7 μ s
23, 24	24bit	Trigger shutter mode 1/50000s ~ 1/5s Setting range = 6 μ s ~ 200ms 1 μ s step Preset Shutter_time (μ s) = (Setting value) + 14 μ s Width Shutter_time (μ s) = (Trigger Pulse Width) + 14 μ s

5.3. White Balance Function (Valid only for VCC-3CL5R)

White Balance Mode

Address	Data	Description
30	0	Through mode (Rgain= Ggain=Bgain)
	1	One Push White Balance mode
	2	Manual White Balance mode

Manual White Balance Value

Address	Data	Description
31	10bit	Red gain 0 ~ 400% default: 100
33	10bit	Blue gain 0 ~ 400% default: 100

Mode: 2 Valid when Manual White Balance mode is selected.

This is the function to adjust white balance of the image adjusting Red/Blue gain manually, in case of when "Gain control mode" is selected as Master Gain with RAW output camera.

Adjustable color temperature range = 2700K ~ 10000K

One Push Trigger

Address	Data	Description
34	1	One Push Trigger Address 34 is only SU Command

Example of manual color temperature settings

Color temperature	MWB R/B gain	
	R gain (%)	B gain (%)
2800K	126	378
3200K	144	322
4000K	174	257
4500K	189	232
5500K	213	201
6500K	232	182
9000K	264	156

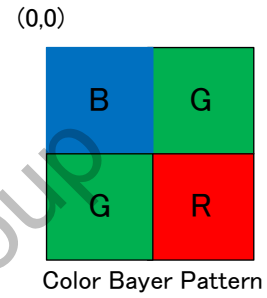

Aegis Electronic Group
www.aegiselect.com

5.4. ROI Function

Address	Data	Description				
50	0	2064(H) x 1544(V) default offset(x,y) = (0, 0)	Frame rate (fps)			Lens
			3Tap	2Tap	1Tap	
	1	1920(H) x 1200(V) offset(x,y) = (72, 172)	55.69	45.48	22.78	2/3
	2	1296(H) x 1024(V) offset(x,y) = (384, 260)	71.24	58.17	29.14	1/2
	3	1008(H) x 1008(V) offset(x,y) = (528, 268)	83.11	67.87	34.00	1/2
	4	816(H) x 600(V) offset(x,y) = (624, 472)	84.39	68.91	34.52	1/3
	5	648(H) x 480(V) offset(x,y) = (708, 532)	138.87	113.40	56.81	1/4
	15	Manual ROI Function Setting values with the Address 51 ~ 54				

Manual ROI Setting Values

Address	Data	Description	
51	12bit	x: Column First Position Range: 0 ~ 1800 multiples of 4	default: 0
52	12bit	y: Row First Position Range: 0 ~ 1536 multiples of 4	default: 0
53	12bit	w: Column Width Range: 264 ~ 2064 multiples of 12	default: 2064
54	12bit	h: Row Height Range: 8 ~ 1544 multiples of 4	default: 1544

ROI function is to be used to cut out any area.

Preset values are cut out by the center.

With Manual ROI, the starting point X: Column First Position and Y: Row First Position shall be set with the multiple numbers of four. And cut out area w: Column Width shall be set with the multiple numbers of twelve, and y: Row Height shall be the multiple numbers of four.

As to frame rate, H direction line is the constant value per Tap, nevertheless ROI area. It is determined by the number of V line. ROI function and Sub-sampling function cannot be used at the same time.

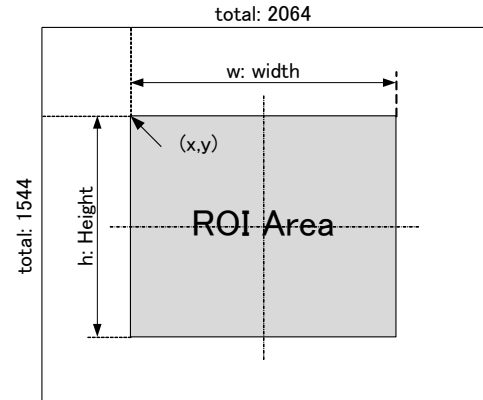

Manual ROI

ROI area does not change if you change only setting values of the Address 51 ~ 54. To enable setting values effective, execute Manual ROI Function command of the Address 50, Data 15 after setting.

Restrictions on Manual ROI settings

x: Column First Position + w: Column Width \leq 2064

y: Row First Position + h: Row Height \leq 1544

Formula for ROI frame rate to read out at Continuous Mode

3tap ROI frame rate = ((Active Vline) + 32 = (V total lines)) x 1line: 11.39 μ s

2tap ROI frame rate = ((Active Vline) + 32 = (V total lines)) x 1line: 13.95 μ s

1tap ROI frame rate = ((Active Vline) + 32 = (V total lines)) x 1line: 27.85 μ s

Formula for the minimum trigger input cycle to read out at Trigger Shutter Mode with ROI function

3tap Shortest Interval on Trigger input = (Shutter time) + ((Active Vline) + 33) x 1line: 11.39 μ s

2tap Shortest Interval on Trigger input = (Shutter time) + ((Active Vline) + 33) x 1line: 13.95 μ s

1tap Shortest Interval on Trigger input = (Shutter time) + ((Active Vline) + 33) x 1line: 27.85 μ s

5.5. White Defect Pixel Correction

To execute defective pixels correction, each correction value must be set via SFA command.

[Note] **Please note that white point correction data at ex-factory shall be deleted when defective pixels detection is executed.**

Never execute any addresses other than the addresses specified below via SFA or GFA command after the camera is powered up.

Since the coordinate of white points are saved only in the memory by the command, please reboot the camera to reflect the information.

Please set the camera operation to continuous readout shutter operation (Continuous Shutter Mode).

Also, please be noted that correction function become invalid when flip function is valid, because the coordinate of defective pixels change.

Example of defect pixel correction:

SFA 100 64 (Set as 12bit value)

In this case, the pixels with white point level over four shall be corrected at Gain 0dB with 8bit output.

Command	Parameter 1	Parameter 2~7	Function
GFA	Address	not used	Acquire setting information
SFA	Address	Data	Change camera settings

Address	Data	Description
100	12bit	White point defective pixels detection (Via SFA command) Please save the pixel correction data right after the execution of the command, and reboot the power to reflect the data. Set 0 ~ 4095 of threshold value for detect level. The maximum correction number is 256. The number of pixels detected shall be indicated via GFA command.

6. Dimensions

6.1. Camera Outline Drawing

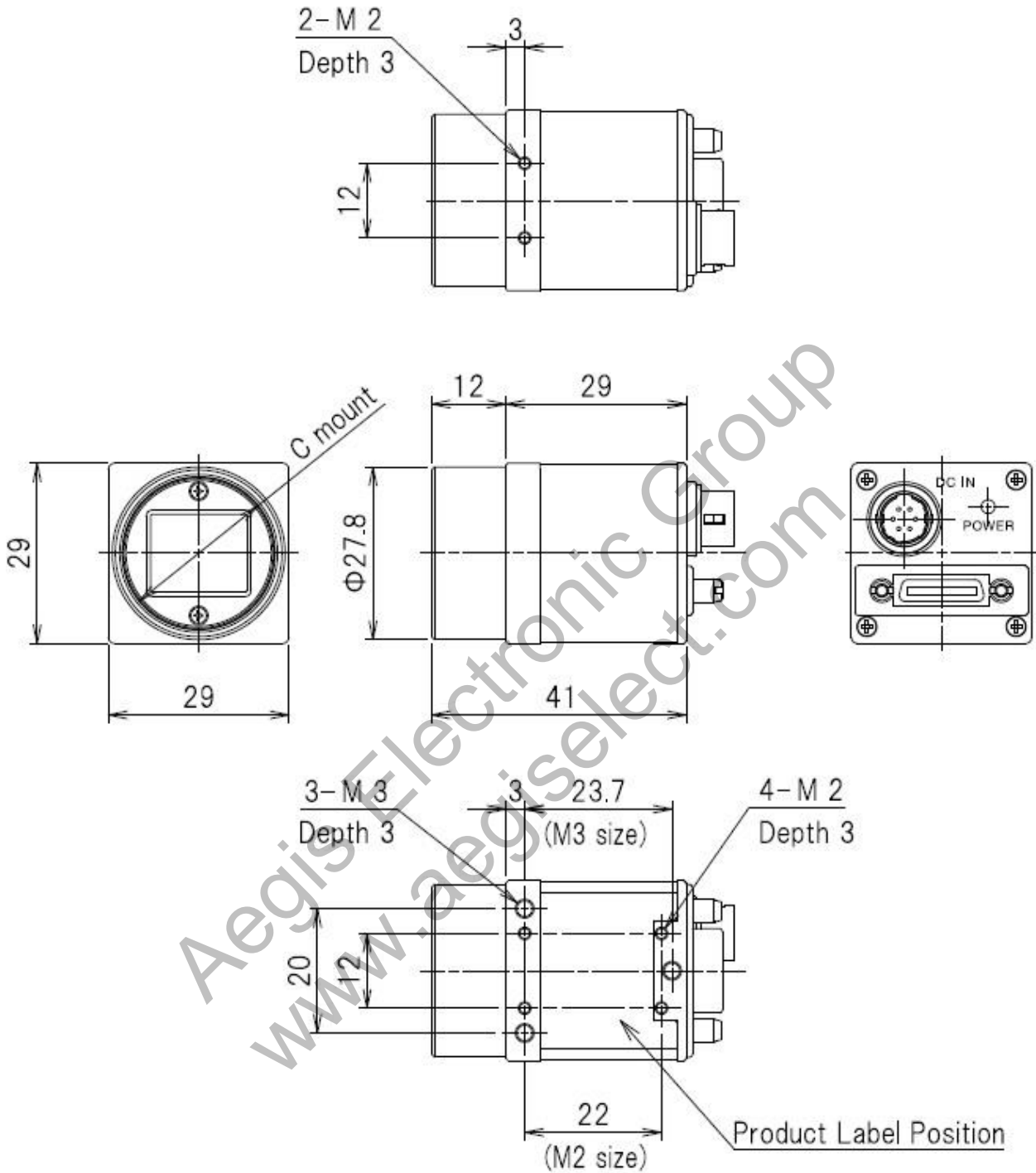

2) C mount screws comply with ANSI/ASME B1.1.1-32UN(2B).

1) Screw length from the lens mount surface shall be less than 6mm. And protruding portion of the C mount lens shall be less than 10mm.

935-0054-00
(Unit:mm)

6.2. Sensor Optical Axis Accuracy

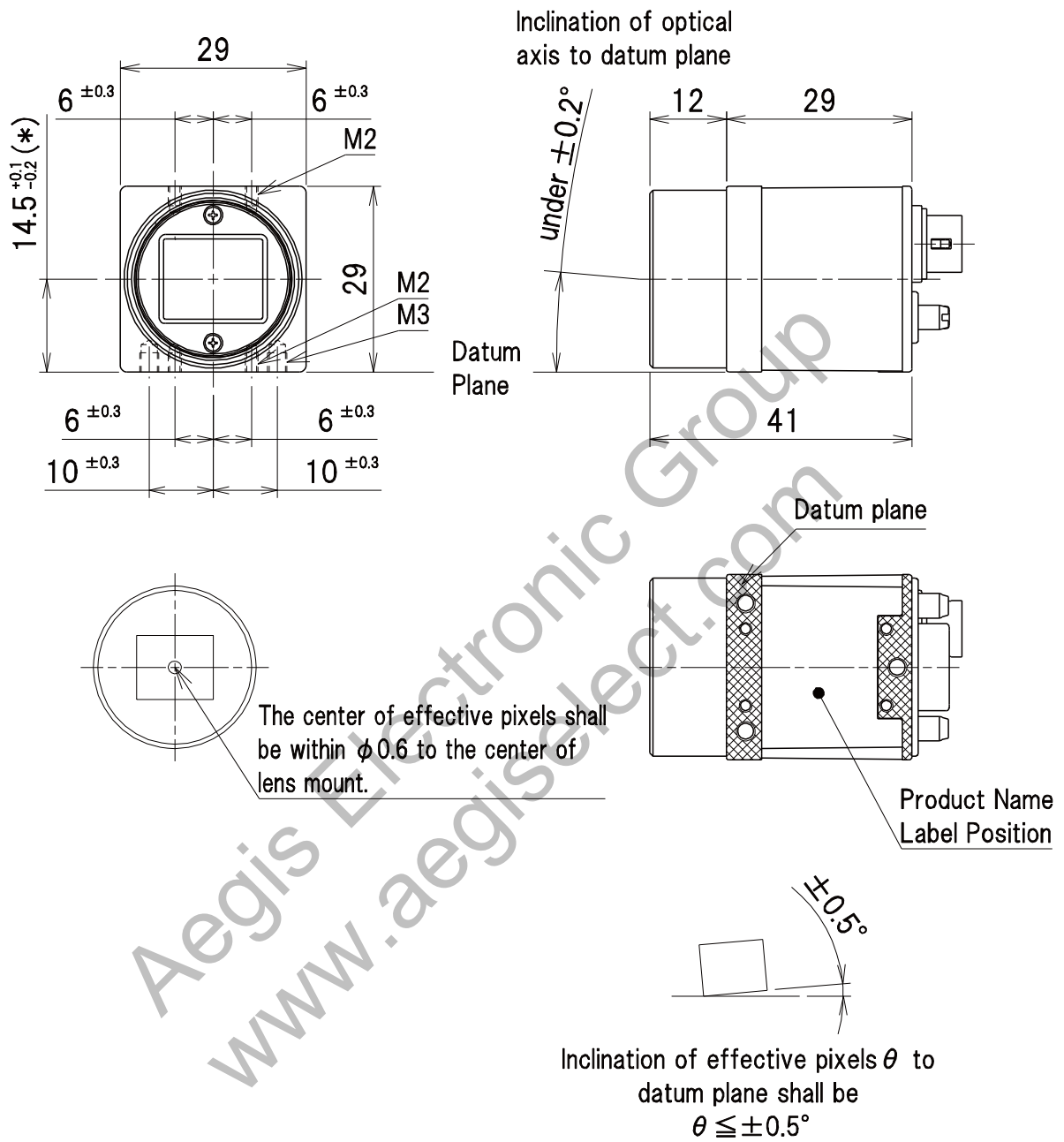

(*)Dimension from datum plane to the center of lens mount.

937-0009-01
(Unit:mm)

7. Case for Indemnity (Limited Warranty)

7.1. Product Warranty

- The term of warranty of this product is within 3 years from the date of shipping out from our factory. If you use the product properly and discover a defect during the warranty period, and if that was caused by designing or manufacturing, CIS Corporation, at its option, repairs or replaces it at no charge to you. However, natural wastage, abrasion, or deterioration of component parts shall be charged to exchange them. Also, correction of defective pixels occurred after shipment, or exchange the sensor itself shall be charged.
- CIS repairs the products expired the warranty period on charged basis as long as it is repairable.

7.2. CMOS Pixel Defect

- CIS compensates the noticeable CMOS pixel defects found at the shipping inspection prior to our shipment. On very rare occasions, however, CMOS pixel defects might be noted with time of usage of the products. Cause of the CMOS pixel defect is the characteristic phenomenon of CMOS sensor itself and CIS is exempted from taking any responsibilities for them. Should you have any questions on CMOS pixel defects compensation please contact us.

8. Supplementary Note

8.1. Product Support

Should you have any problems in function of the product you purchased, and if you need our further analysis and/or repair, please contact the dealer you purchased it from. When you do so, please provide us with the following detailed information. Customers' information provided shall be handled and controlled with care and shall not be disclosed to any other party without previous notice.

Information need to be provided:	①	Reported date
	②	Your company name, Division name, and Your name
	③	Product name, serial number, camera version information
	④	General description of your company's system/equipment
	⑤	Camera operation mode used, such as trigger operation, shutter time, ROI area, and others.
	⑥	Problems (Explain the problems as detail as possible. Images, pictures, wave form data, and others are appreciated.

8.2. Ordering Information

- Please be noted that baud rate cannot be changed by user settings, but only by factory settings at its delivery.
- If you need to change Default setting of Baud rate, please specify at ordering with the model names below.

Model names	Baud rate (bps)
VCC-3CL5M, VCC-3CL5R	9,600
VCC-3CL5M-1, VCC-3CL5R-1	115,200