

# CIS

**CoaXPress I/F  
25M CMOS (RAW) Camera**

# VCC-25CXPHSR

**Product Specifications  
& Operational Manual**

**CIS Corporation**

## Table of Contents

1.	Handling Precautions.....	1
1.1.	Camera Handling Precautions.....	1
1.2.	Restrictions on Applications.....	1
1.3.	Disclaimers (Exception Clause).....	1
1.4.	Known Phenomenon (Errata).....	1
1.4.1	Malfunction with Horizontal ROI.....	1
2.	Product Outline.....	2
2.1.	Features.....	2
2.2.	Accessories.....	2
2.3.	Ordering Information.....	2
3.	Specifications.....	3
3.1.	General Specifications.....	3
3.2.	Input and Output Specifications.....	4
3.2.1	Trigger Input (12pins circular connector No.11 pin).....	4
3.2.2	General Output (12pins circular connector No.6pin, No.7pin).....	4
3.3.	External Connector Pin Assignment.....	5
3.3.1	12pins Circular Connector.....	5
3.3.2	75Ω HD-BNC Connector.....	5
3.3.3	LED Indicator.....	6
3.4.	Spectral Response.....	6
4.	Camera Functions.....	7
4.1.	Camera Interface.....	7
4.2.	How to Save and Initialize Settings.....	7
4.3.	Link Speed and Link Count.....	7
4.4.	Pixel Format.....	8
4.5.	Frame Rate.....	8
4.6.	Trigger Mode.....	9
4.6.1	Internal Sync. Mode (Free Run Mode).....	9
4.6.2	External Sync. Mode (Trigger Mode).....	9
4.6.3	Restrictions on Timing for Trigger Pulse Input.....	11
4.6.4	Input Timing of Trigger Pulse and Delay Time to Start Exposure.....	11
4.6.5	Fixed Trigger Shutter Mode.....	12
4.6.6	Pulse Width Trigger Shutter Mode.....	13
4.7.	Gain.....	14
4.8.	Gamma Correction.....	14
4.9.	Exposure Time.....	14
4.10.	Partial Scan (ROI).....	15
4.11.	Flip.....	16
4.12.	Defective Pixel Correction.....	16
4.13.	Shading Correction.....	19
4.14.	Black Level Adjustment.....	19
4.15.	Test Pattern Indication.....	20
4.16.	Cursor Indication.....	20
4.17.	LED Operational Mode.....	20
4.18.	Camera I/O.....	21
4.19.	User ID.....	21

---

4.20.	Temperature Indication .....	21
4.21.	White Balance .....	22
5.	Factory Settings .....	23
6.	Dimensions.....	24
6.1.	Camera Dimensions (VCC-25CXPHSR-F).....	24
6.2.	Optical Axis Accuracy (VCC-25CXPHSR-F).....	26
6.3.	Optical Axis Accuracy (VCC-25CXPHSR).....	27
7.	Case for Indemnity (Limited Warranty).....	28
7.1.	Product Warranty.....	28
7.2.	CMOS Defective Pixels .....	28
7.3.	Product Support .....	28

Aegis Electronic Group  
www.aegiselect.com

## 1. Handling Precautions

### 1.1. Camera Handling Precautions

- Do not use or store camera in dusty or humid places.
- Do not apply excessive force, vibration, or static electricity that could damage camera. Please handle camera with care.
- Do not shoot direct images that are extremely bright (e.g., strong light source, sun, etc.). When extremely strong light source is shot, smear or blooming may occur. Put the lens cap on when camera is not in use.
- Follow the instructions in [Chapter 3.3., "External Connector"](#) for connecting camera. Improper connection may cause damages not only to the camera but also to the connected devices.
- Confirm mutual ground potential carefully before connecting camera to monitors or computers. Any AC leak from the connected devices may cause damages or destroy the camera.
- Do not apply excessive voltage. (Use only the specified voltage.) Unstable or improper power supply voltage may cause damages or malfunction of the camera.
- Voltage ripple of camera power DC+12V±10% must be within ±50mV. Improper power supply voltage may cause noises on video signals.
- Rise time of camera power supply voltage must be less than +10V, Max. 60ms. Please avoid noises like chattering.
- Our warranty does not apply to damages or defects caused by irregular and/or abnormal use of the product.

Our warranty does not apply to damages or defects caused by neglecting the instructions and precautions explained in this manual.

### 1.2. Restrictions on Applications

- The camera must not be used for any nuclear equipment or aerospace equipment with which mechanical failure or malfunction could result in serious bodily injury or loss of human life.
- The camera must not be used under conditions or environments other than those specified in this manual.

### 1.3. Disclaimers (Exception Clause)

CIS should not be liable for any damages or losses if;

- damages or losses are caused by earthquake, lightning strike, fire, flood, or other acts of God.
- damages or losses are caused by deliberate or accidental misuse by user, or failure to observe information and instructions explained in this manual.
- damages or losses are caused by repair or modification conducted by user or any unauthorized party.

### 1.4. Known Phenomenon (Errata)

#### 1.4.1 Malfunction with Horizontal ROI

- Camera does not output the right edge of image (approx. 60 columns) properly under the following conditions.

Conditions		
Device Version = 39~41	(1)	With CXP6_x1, Bayer8(Mono8), and Width=1248
	(2)	With CXP6_x1, Bayer8(Mono8), and Width=1280

## 2. Product Outline

VCC-25CXPHSR and VCC-25CXPHSR-F are high-speed color cameras with CoaxPress interface. (VCC-25CXPHSR-F is a model with Fin for cooling). Using 1.1", global shutter type 25M pixels CMOS image sensor, frame rate reaches 150fps with CXP12\_x4 8bit. Complies with CoaXPress Version 1.1.1 and transfers data up to 40m with CXP-6 and 24m with CXP-12.

Must have function ready for Machine Vision applications such as trigger shutter, ROI, Gain, shading correction, and defective pixels correction. Suitable for various Machine Vision inspection systems, medical imaging, and life science imaging systems.

### 2.1. Features

- VCC-25CXPHSR-F: 65mm (H) x 125mm (W) x 93.3mm (D) with heatsink  
VCC-25CXPHSR: 65mm (H) x 65mm (W) x 93.3mm (D) without heatsink
- Global shutter type, CMOS sensor (Raw)
- Complies with CoaXPress1.1.1. Supports CXP-12
- Supports Maximum 4 lanes
- Maximum cable length: Approx. 24m with CXP-12, Approx. 40m with CXP-6
- ROI function (Vertical 16 areas)
- Exposure setting, Gain setting
- External trigger mode (Fixed trigger shutter mode/Pulse width trigger shutter mode)
- Complies with GenICam
- M48 lens mount

### 2.2. Accessories

- Standard accessory
  - Lens cap
- Optional accessories
  - M48 to F lens mount conversion adaptor
  - M48 to C lens mount conversion adaptor

### 2.3. Ordering Information

- VCC-25CXPHSR-F      with heatsink
- VCC-25CXPHSR        without heatsink

## 3. Specifications

## 3.1. General Specifications

<b>Electrical Specifications</b>			
Image sensor	Sensor type	1.1", Global shutter type CMOS sensor	
	Effective pixels	5120 (H) × 5120 (V)	
	Unit cell size	2.5μm (H) × 2.5μm (V)	
Interface		Complies with CoaXPress 1.1.1. Supports CXP12_x4, CXP12_x1, CXP6_x4, and CXP6_x1	
Video output format		Mono8 / Mono10/ BayerGB8 / BayerGB10 BayerBG8/ BayerBG10 (with horizontal flip)	
Frame rate	CXP12_x4 8bit/10bit	150.3fps / 141.2fps	
	CXP12_x1 8bit/10bit	44.3fps / 35.3fps	
	CXP6_x4 8bit/10bit	87.9fps / 67.5fps	
	CXP6_x1 8bit/10bit	22.6fps / 18.1fps	
Sync. system		Internal sync.	
Resolution (maximum resolution)		5120 (H) × 5120 (V)	
Video signals (Gain 0dB)	White clip level	FFh	with 8bit
	Set up level	01±01h	with 8bit, with factory setting
	Dark shading	0~1 digit (H/V)	with 8bit, with factory settings
Sensitivity		F2.8 2000lx (Shutter speed 1/150s, Gain 0dB)	
Minimum illumination		F1.4, 54lx with CXP12_x4 8bit (Gain+18dB, Shutter OFF [Exposure time 6667us], level=50%)	
Gain variable range		x1 ~ x32 [Note: guaranteed range is x1~x8]	
Shutter speed		6[μs] ~ 2[s] (Recommendation is over 50[us]). *The actual exposure time for the set value is $T_{exp}[us] = \{ExposureTime\} + 7.73[us]$ .	
Gamma correction		Valid ( $\gamma=0.1\sim 1.8$ )	
Trigger mode		Free run mode (Camera internal trigger) Trigger mode (Host, External terminal) <ul style="list-style-type: none"> <li>· Fixed trigger shutter</li> <li>· Pulse width trigger shutter</li> </ul>	
Partial scan		Maximum 16 areas. User can change vertical and horizontal sizes for ROI. Note): Changing horizontal size is enabled only with Mono8 or BayerRG8/GB8.	
Power requirements		Ext-Vin: 12V±10%, PoCXP: 18.5 ~ 26V	
Power consumption		16.0W max. (CXP12_x4, 10bit), [with free run]	

<b>Mechanical Specifications</b>			
Dimensions	VCC-25CXPHSR-F	H: 65mm W: 125mm D: 93.3mm excluding projection.	
	VCC-25CXPHSR	H: 65mm W: 65mm D: 93.3mm excluding projection.	
Weight		VCC-25CXPHSR-F: Approx. 750g, VCC-25XPHSR: Approx. 465g	
Lens mount		M48 mount	

Environmental Specifications			
Safety/Quality standard			
UL: Complies with UL standard including materials. CE EMC: 2014/30/EU Emission: EN61000-6-4:2007+A1:2011 Immunity: EN61000-6-2:2005 RoHS: 2011/65/EU (EU)2015/863 Complies with EN50581 (RoHS2)			
Durability	Vibration	Acceleration	: 98m/s <sup>2</sup> (10G)
		Frequency	: 20 ~ 200Hz
		Direction	: X, Y, and Z 3 directions
		Testing time	: 120min for each direction
	Shock	No malfunction with 980m/s <sup>2</sup> (100)G for ±X, ±Y, and ±Z 6 directions without packaging.	
Operational temperature		VCC-25CXPHSR-F (with heatsink): 0 ~ +45°C VCC-25CXPHSR (without heatsink): 0 ~ +35°C Humidity: 20 ~ 80%RH with no condensation.	
Storage temperature		-25 ~ +60°C Humidity: 20 ~ 80%RH with no condensation.	

### 3.2. Input and Output Specifications

#### 3.2.1 Trigger Input (12pins circular connector No.11 pin)

- 5.0V, 3.3V CMOS level / TTL level
- Input voltage Low: 0.6Vdc (Max.), High: 2.0Vdc (Min.)
- To use this terminal, set Trigger Source of AcquisitionControl to Line0.

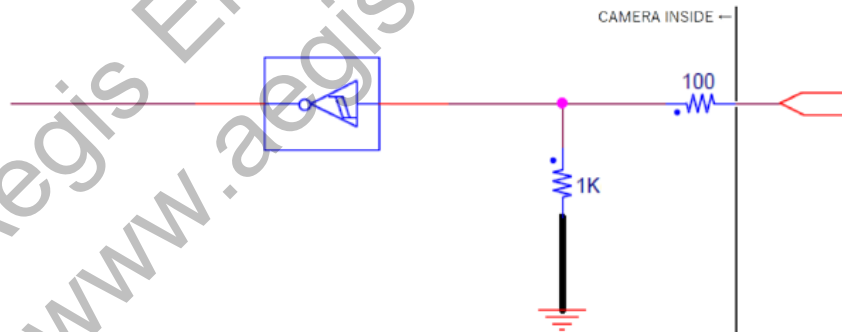

#### 3.2.2 General Output (12pins circular connector No.6pin, No.7pin)

- 5.0V CMOS logic level output
- Output voltage Low: 0.3Vdc (Max.), High: 4.6Vdc (Min.)

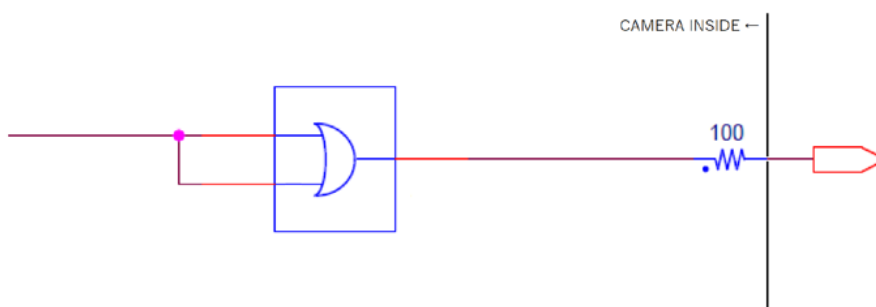

3.3. External Connector Pin Assignment

3.3.1 12pins Circular Connector

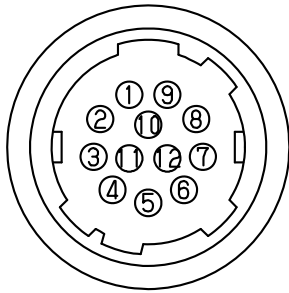

HR10-10R-12PA (73)  
(HIROSE) or equivalent

Pin No.	Signals	Note
1	GND	Ground camera chassis
2	POWER	DC+12V
3	GND	Ground camera chassis
4	POWER	DC+12V
5	GND	Ground camera chassis
6	GPO1	General output (Low with initial setting)
7	GPO2	General output (Low with initial setting)
8	NC	
9	NC	
10	NC	
11	TRIGGER	Trigger input
12	GND	Ground camera chassis

※ NC=Non-Connection. Do not connect anything to the terminal.

※ Recommendation on power source voltage.

1. Power source voltage: E[V]
2. Length of cable to use: l[m]
3. Resistance value per 1m of cable: r[Ω/m]

Following is the formula to calculate output voltage of external power supply:

$$E[V]=12[V]+r[\Omega/m]\times l[m]\times 1.3[A]$$

Please make sure to supply appropriate E[V]. Voltage from external power supply must meet specifications specified in Section 3.1. to input to camera.

- ※ Power supply via 12pins circular connector and power supply via CoaXPress cable are mutually exclusive. Make sure to stop power supply from PoCXP cable when you supply power from 12pins circular connector.
- ※ Power supply cable length must be less than 30m.

3.3.2 75Ω HD-BNC Connector

□ CoaXPress video output signals.

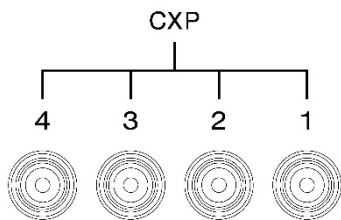

(Amphenol RF)

- ※ With power supply via PoCXP, please make sure the amount of electric current available with frame grabber board. Outer diameter of CXP cable must be over 4mm (core wire: copper single wire 23AWG (0.57 φ) and the cable length must be less than 8m.

### 3.3.3 LED Indicator

□ With LED indicator ON, lighting patterns show the camera status by its way of lighting.

OFF	No Power supply.
Green/Orange Fast Blinking [12.5Hz]	Disconnection of cables.
Green Lighting	Completion of connection between device and host.
Green Fast Blinking (With 12.5Hz, trigger mode, lights for exposure period.)	Transmitting video data.
Orange Slow Blinking [1Hz]	Waiting for a trigger input.
Red Fast Blinking (With 12.5Hz, trigger mode, lights for exposure period.)	Image transmission error or inappropriate trigger input.

### 3.4. Spectral Response

※ Excludes characteristics of lens, IR cut filter, and light source.

※ Representative values. Not guaranteed values.

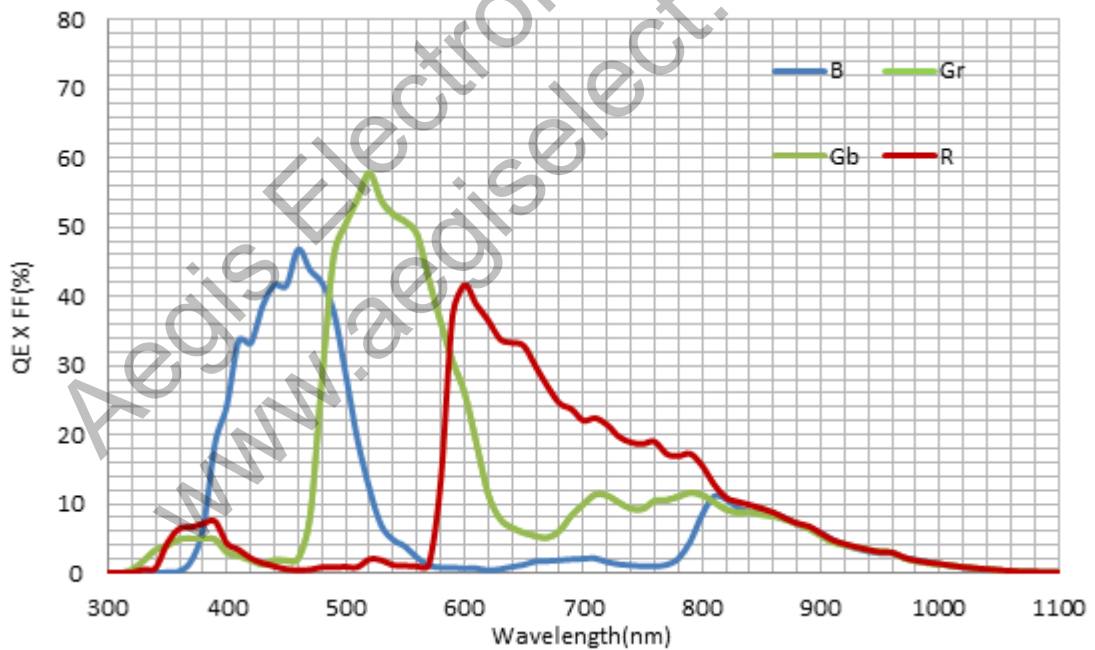

4. Camera Functions

4.1. Camera Interface

- Complies with CoaXPress1.1.1 standard.

4.2. How to Save and Initialize Settings

UserSets	
UserSetSelector	Default [Not subject to save] UserSet0
UserSetLoad	(Execute)
UserSetSave	(Execute)

- Select UserSet0 with UserSetSelector and execute "UserSetSave" to save settings in operation into the camera non-volatile memory.
  - Default (factory settings) is not subject for UserSetSave.
  - Values of UserSetSelector are not subject to save with UserSetSave. Please set values before executing UserSetLoad or UserSetSave.
- UserSetLoad loads Default (factory setting) or UserSet0 (user save area) selected with UserSetSelector.
  - ※Do not execute UserSetLoad while grabbing (acquiring images).
- Defective pixel correction values, shading correction values, and UserID are not subject to UserSetLoad for Default. (Camera keeps those values).
- ConnectionConfig and PixelFormat keep settings in operation even when executing UserSetLoad for Default or UserSetLoad for UserSet0. Therefore, please set them with commands.

UserSetSelector	Default	UserSetLoad >Excute	= Initialize(Factory setting)
	UserSet0	UserSetLoad >Excute	= Initialize(User setting)
		UserSetSave >Excute	= User setting Save

4.3. Link Speed and Link Count

Transfer Control	
ConnectionConfig	CXP12_X1
	CXP12_X4
	CXP6_X1
	CXP6_X4

- CXP12: Link speed=12.5Gbps
- CXP6: Link speed=6.250Gbps
- X1: Link count=1
- X4: Link count=4

## 4.4. Pixel Format

ImageFormatControl	
PixelFormat	BayerGB8 BayerGB10 BayerBG8 BayerBG10 Mono8 Mono10

BayerGB8: Bayer (GBRG) 8bit (ReverseX= Off, ReverseY = Valid with Off)

BayerGB10: Bayer (GBRG) 10bit (ReverseX= Off, ReverseY = Valid with Off)

BayerBG8: Bayer (BGGR) 8bit (ReverseX= On, ReverseY = Valid with Off)

BayerBG10: Bayer (BGGR) 10bit (ReverseX= On, ReverseY = Valid with Off)

Mono8: Monochrome 8bit

Mono10: Monochrome 10bit

※ Please do not change PixelFormat while grabbing (acquiring images).

※ Please reset PixelFormat when changing Reverse settings.

## 4.5. Frame Rate

Acquisition Control	
AcquisitionFrameRate	(Read only)

• AcquisitionFrameRate: Frame rate for internal sync mode (free-run).

According to link speed and link count, pixel format, and ROI (width and height), the formula below calculates frame rate.

$$\text{Frame rate} = 1,000,000 / \{Tline \times (Height + 31)\} \text{ [fps]}$$

Refer to the table below for Tline (=Time for 1H) with units [us].

(Pixel Format = with Bayer\*8/Mono8)

ConnectionConfig	5120 ≥ Width > 2560	2560 ≥ Width > 1280	1280 ≥ Width
CXP12_x4	124/96 ≐ 1.29	1.292	1.292
CXP6_x4	212/96 ≐ 2.21	1.292	1.292
CXP12_x1	420/96 = 4.375	2.209	1.292
CXP6_x1	824/96 = 8.584	4.375	2.209

(Pixel Format = with Bayer\*10/Mono10)

ConnectionConfig	Width=5120 (※)
CXP12_x4	132/96 ≐ 1.375
CXP6_x4	276/96 ≐ 2.875
CXP12_x1	528/96 = 5.500
CXP6_x1	1032/96 = 10.750

※ Not support horizontal ROI with Bayer\*10, Mono10. Width is 5120 fix.

©2020 - 2024 CIS Corporation. All rights reserved.

## 4.6. Trigger Mode

### 4.6.1 Internal Sync. Mode (Free Run Mode)

- This is a mode to use internal triggers continuously generated.
- Turn off TriggerMode and set TriggerSelector to AcquisitionStart.
- The table below shows frame rate when ROI is disabled.

Pixel Format	CXP12_X4	CXP12_X1	CXP6_X4	CXP6_X1
Bayer*8/Mono8	150.3	44.4	87.9	22.6
Bayer*10/Mono10	141.2	35.3	67.5	18.1

### 4.6.2 External Sync. Mode (Trigger Mode)

- This is a mode to input external trigger signals to capture images by any preferred timings.
- Set TriggerSelector to FrameStart, TriggerSource to either Software/LinkTrigger0/Line0, and turn on TriggerMode.

Acquisition Control	
TriggerMode	On/Off
TriggerSelector	AcquisitionStart FrameStart
TriggerActivation	RisingEdge FallingEdge LevelHigh LevelLow
TriggerSource	Software LinkTrigger0 Line0
TriggerSoftware	(Execute)

- TriggerMode
  - On: Enable trigger selected with TriggerSource. (TriggerSelector = FrameStart)
  - Off: Disable trigger selected with TriggerSource. (TriggerSelector = AcquisitionStart)

※Do not change Trigger Mode while grabbing (acquiring) images.

- TriggerSelector
 

This is to select how to start capturing video or its polarity out of the followings.

  - AcquisitionStart: Free run mode [Internal sync. mode]
  - FrameStart: External trigger mode

※Do not change TriggerSelector while grabbing (acquiring) images.

- TriggerActivation
 

This is to select how to start capturing video and its polarity out of the followings.

  - RisingEdge: Fixed trigger shutter mode: Rising edge (Timed).
  - FallingEdge: Fixed trigger shutter mode: Falling edge (Timed).
  - LevelHigh: Pulse-width trigger shutter mode: High active. (Trigger width).

©2020 - 2024 CIS Corporation. All rights reserved.

- LevelLow: Pulse-width trigger shutter mode: Low active (Trigger width).

- TriggerSource

This is to select where to send external triggers.

- Software: TriggerSoftware
- LinkTrigger0: External trigger input from CoaXPress Host Device.  
Please refer to specification manuals of the Host Device such as frame grabber board to know how to generate triggers.
- Line0: External trigger input from 12pins circular connector.

- TriggerSoftware: Software trigger

Camera generates a trigger to capture one frame image by executing this command.

- ※Set TriggerSource to Software.
- ※Set TriggerActivation to RisingEdge.

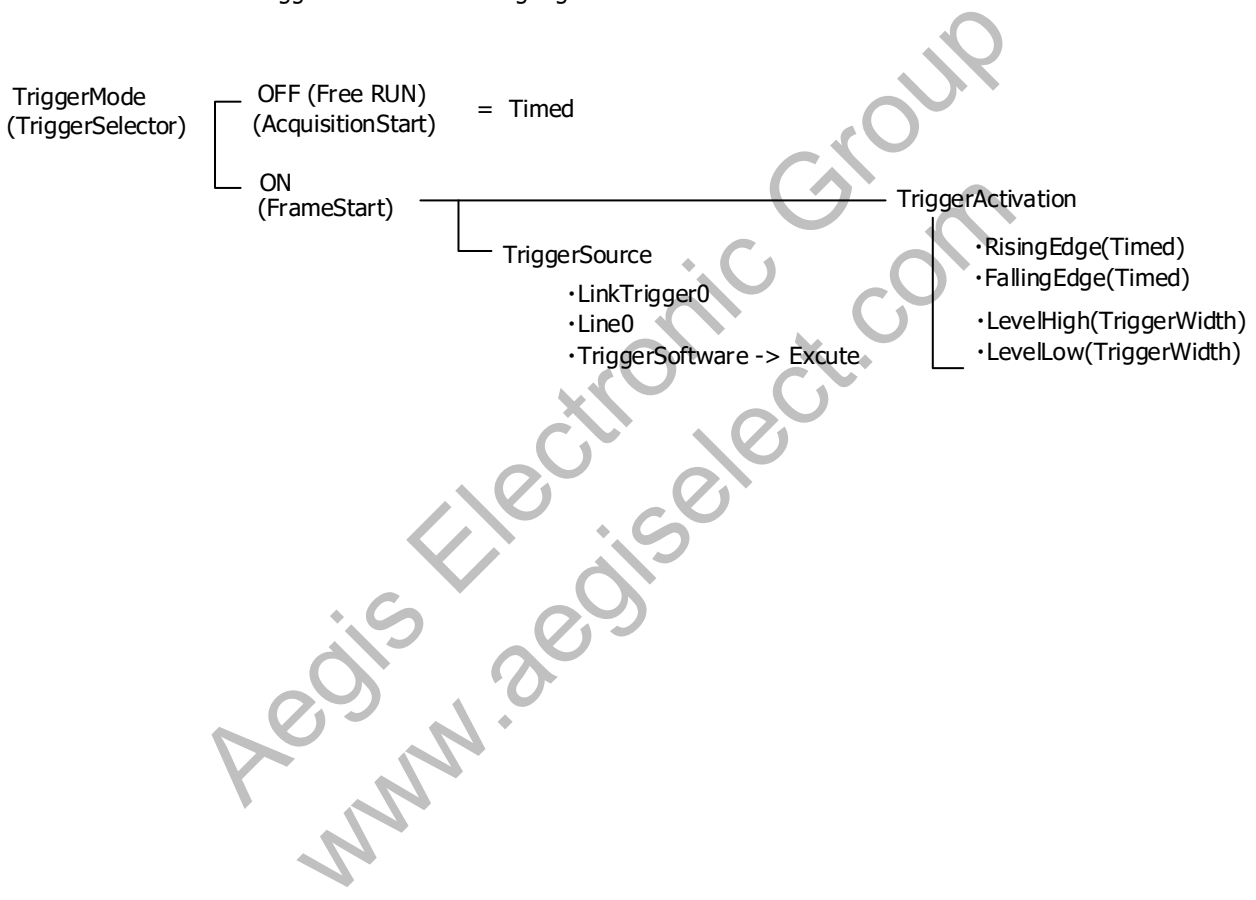

4.6.3 Restrictions on Timing for Trigger Pulse Input

- User can input a trigger for the next frame while camera is reading out signals. However, do not input a trigger pulse to end exposure while camera is reading out signals. In other words, a trigger pulse to start reading out signals for the next frame before completion of reading out signals for the prior frame is restricted.

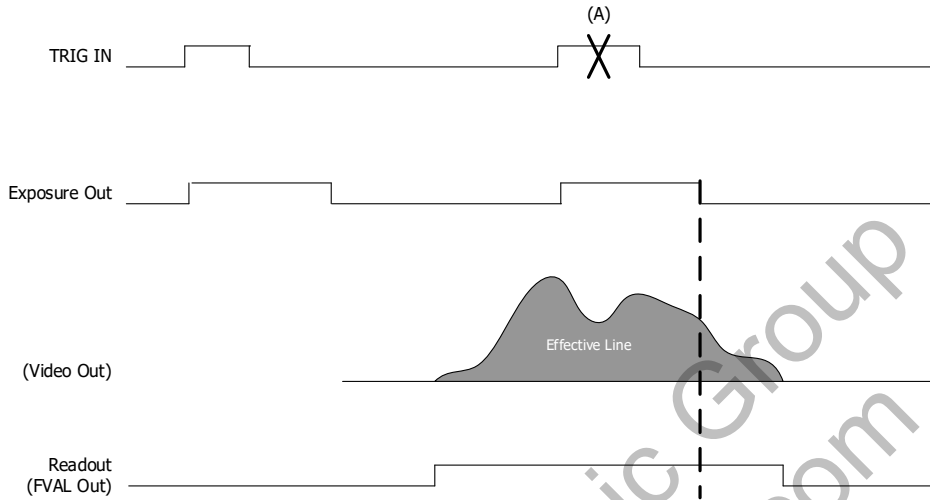

- If there is a trigger input with restricted timing explained in the above, or with timing to end exposure immediately after FVAL becomes "L", camera may stop outputting images or show black color only.

Acquisition Control	
IllegalTriggerFlag	0 or 1

- If there is a trigger input with restricted timing, "IllegalTriggerFlag" becomes "1".

Device Control	
ErrorFlagReset	(Execute)

- This is to reset IllegalTriggerFlag to "0".

4.6.4 Input Timing of Trigger Pulse and Delay Time to Start Exposure

- There are some delay time between trigger input to camera and actual start of exposure. The amount of delay time varies according to timing of trigger input.

Trigger input timing and exposure delay time [μs]

	Delay time with start of exposure	Delay time with end of exposure
With non-overlapping read out operation (Exposure delay time (A) in the timing chart of the next page.)	0[us]	7.73[us]
With overlapping read out operation (Exposure delay time (B) in the timing chart of the next page.)	2 x Tline (*)	7.73[us]

\*Please refer to [Section 4.5, Frame Rate](#) for Tline values.

## 4.6.5 Fixed Trigger Shutter Mode

- This is a mode to start exposure with external trigger input and expose for a period set by Exposure Time.
- Set "TriggerSelector" to "FrameStart". Set "TriggerActivation" to "RisingEdge" or "FallingEdge".
- Trigger cycle must be longer than FVAL period (reading out period of frame data).
- Trigger cycle must be longer than exposure time.
- Trigger operation is CLK sync. H-V-sync. reset.
- Trigger pulse width must be  $6\mu\text{s}$  ~ maximum exposure time.
- The maximum exposure time depends on ROI setting, "PixelFormat", and Link rate (Please refer to [Section 4.9, Exposure Time](#)).

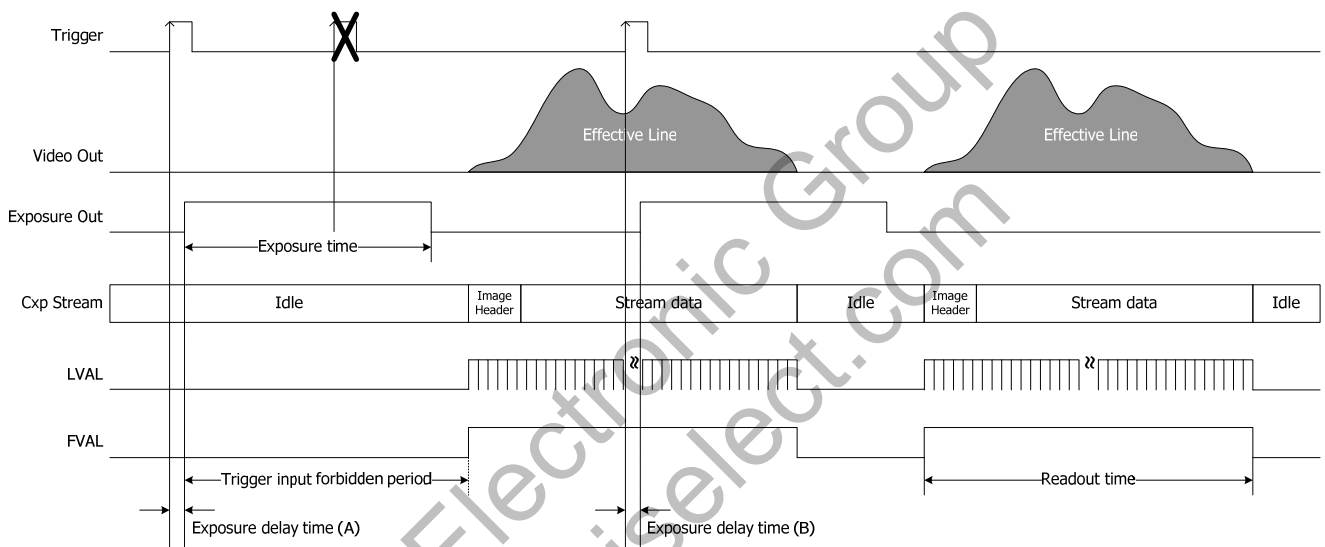

4.6.6 Pulse Width Trigger Shutter Mode

- This is a mode to start exposure with external trigger input and expose for a period of trigger pulse width.
- Set "TriggerSelector" to "FrameStart". Set "TriggerActivation" to "LevelHigh" or "LevelLow".
- Trigger cycle must be longer than FVAL period (reading out period of frame data).
- Trigger operation is CLK sync. H-V-sync. reset.
- Minimum trigger pulse width is 6µs. (Please refer to the restrictions on trigger pulse input.)

The following formula is for the actual exposure time.

$$T_{exp} [us] = \{Pulse\ Width\} + 7.73$$

•Pulse Width : input trigger width [us]

- Functionally, there is no upper limitation. However, noises, lines, pixel-wise FPN, and shading may become noticeable with long time exposure.

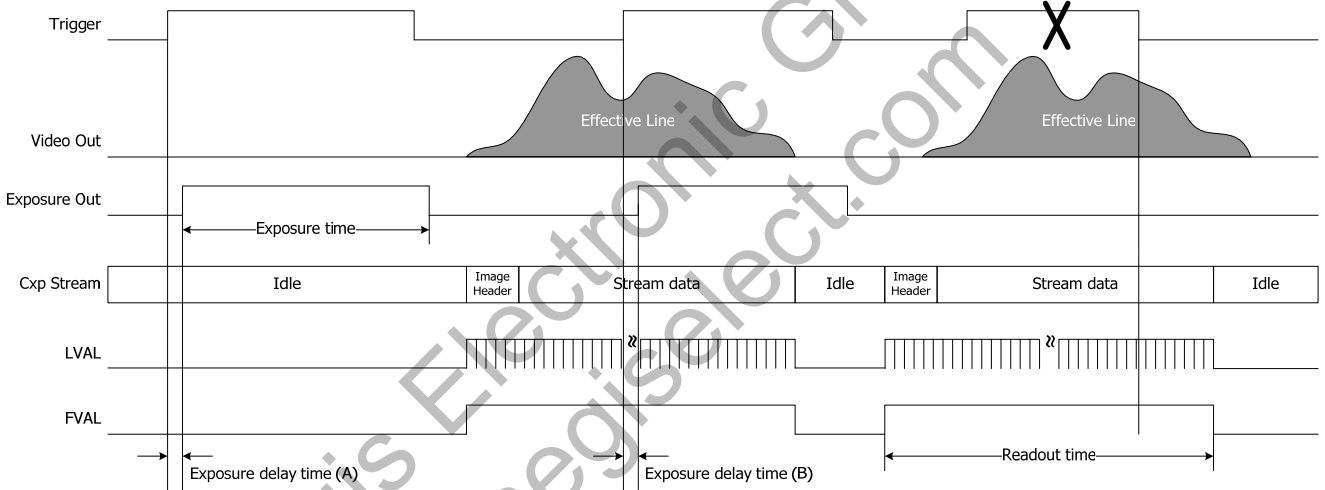

## 4.7. Gain

AnalogControl	
Gain	1.00~32.00

- Gain: Preferred gain settings per 0.01.  
User can set gain values up to x32.00. However, with high gain settings, noise will increase and image quality deteriorates.

## 4.8. Gamma Correction

AnalogControl	
Gamma	0.10~1.80

- Gamma : This is to set gamma correction value per 0.01 step.  
[Note] Camera updates gamma table at the timing of image output.  
With continuous operation mode, camera applies the updated gamma table at the timing of image output after completion of rewriting gamma table (approx. 20ms: refer to Command ACK as a rough guide).  
If user changes gamma coefficient while waiting for a trigger input, camera outputs images with updated gamma table with a trigger after completion of rewriting gamma table.

## 4.9. Exposure Time

Acquisition Control	
ExposureMode	(Read Only) Timed / Trigger Width
ExposureTime	6 $\mu$ s~2s (per 1 $\mu$ s)
ExposureTimeMax	(Read Only)

- ExposureMode: This is to check if the current mode is Timed or Trigger Width.
- ExposureTime: Exposure time (Free run · Fixed trigger mode)

Set exposure time per 1 $\mu$ s.

Minimum value is 6[ $\mu$ s]. Shown value with ExposureTimeMax becomes the maximum value.

With short exposure time, image quality deteriorates. Recommendation is over 50[ $\mu$ s].

The following formula calculates actual exposure time corresponds to setting value.

$$T_{exp} [\mu s] = \{ExposureTime\} + 7.73$$

- ExposureTimeMax: Maximum exposure time

Maximum exposure time corresponds to ROI setting, Pixel Format, and link rate.

## 4.10. Partial Scan (ROI)

- This is to increase frame rate by cutting and reducing read out area.
- User can select up to 16 areas with Y direction.

ImageFormatControl		
RegionSelector	1~16	[Not subject to save]
RegionMode	Off / On	
RegionDestination	Stream0	※Fixed
Width	1024~5120	(Per 32 pixels) (Enabled only with Bayer*8/Mono8)
Height	2~5120	(Per 2 lines)
OffsetX	0~4096	(Per 32 pixels) (Enabled only with Bayer*8/Mono8)
OffsetY	0~5118	(Per 2 lines)

- RegionSelector: This is to select Region to set.  
User can set 16 partial areas with Region 1~16. Select EffectiveRegion to check Width and Height of the effective partial area. Make sure to select EffectiveRegion with RegionSelector to start capturing images.
- RegionMode: On/Off of the selected Region.  
User can check if there is an effective region with EffectiveRegion.  
※Enabled only when Width, Height, OffsetX, and OffsetY are effective.  
※At least one out of region 1~16 must be ON.  
※Enables only one area with shading correction (when ShadingCorrectionDataSelector is other than off).
- RegionDestination: Selection of Stream to output. Fixed with Stream0.
- Width: Width of Region. The same value applies to all region.  
Note). Changing width is enabled only with Bayer\*8 and Mono8.  
Set 5120 with Bayer \*10 and Mono10.
- Height: Height of Region.  
※Make sure that OffsetY and Height do not overlap with other regions.
- OffsetX: Offset for X direction of Region. All regions must have the same value.
- OffsetY: Offset for Y direction of Region.  
※Make sure that OffsetY and Height do not overlap with other regions.

[Note]

After changing partial scan (ROI), check ExposureTime and re-set ExposureTime if necessary.  
Corresponding to change of Height, ExposureTime clips if it exceeds ExposureTimeMax.

[Reference]

- Please refer to the chart below for details on frame rate with Single ROI: CXP12x4 output.  
※Single ROI: 1 area with line number setting for Y direction.

	5120x5120	5120x2560	5120x1280	5120x640
Bayer*8/ Mono8	Approx. 150fps	Approx. 298fps	Approx. 590fps	Approx. 1152fps
Bayer*10/ Mono10	Approx. 140fps	Approx. 280fps	Approx. 554fps	Approx. 1082fps

4.11. Flip

ImageFormatControl	
ReverseX	On/Off
ReverseY	(Read Only) Off fix

- ReverseX : Flip the image with X direction.

4.12. Defective Pixel Correction

- This is a function to detect and correct defective pixels in output data from the sensor.
- There are two types of defective pixel data.
  - Defective data registered at factory  
Black and white defective pixel data registered upon shipment from our factory. These data cannot be over-written.
  - Defective data registered by user  
Data registered by user. In addition to the correction of defective pixel data registered upon shipment, we provide a method to update the defective pixel data. With DefectPixelDefault command, user can delete these user-registered data.
- User can register up to 1024 points. (Note: Up to 64 points per CH.)  
[CH (Channel)]  
Camera performs image processing with 16 CH interleave.

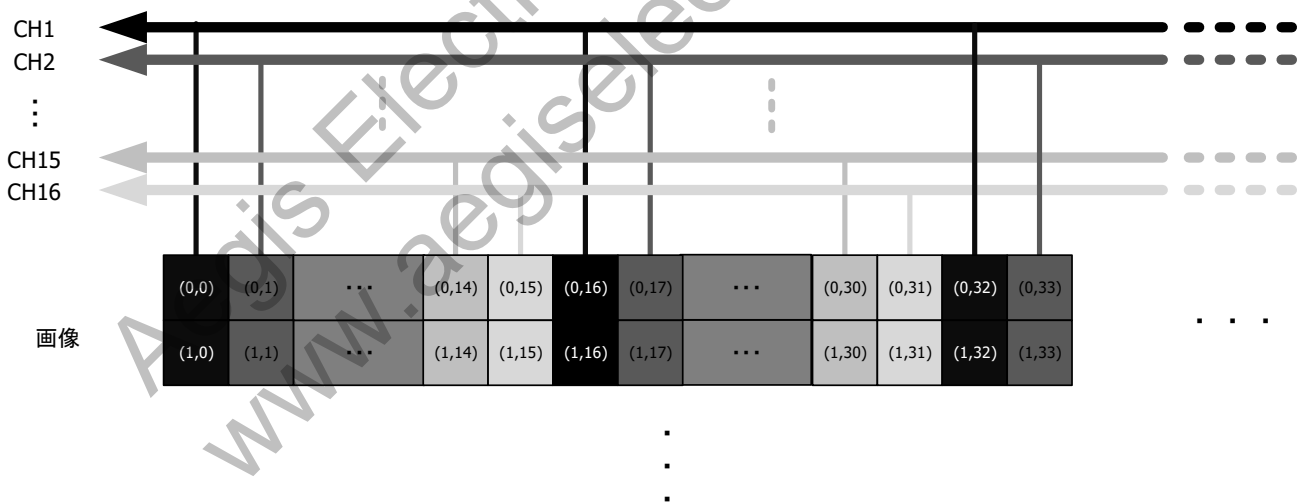

- Enable or disable Defective Pixel Correction  
This is to enable or disable defective pixel correction function. Function controls both defective pixel correction data registered at factory and registered by user at one time.
- Updating defective pixel data with coordinates X and Y.  
This is to update defective pixel data by specifying coordinates to add or delete.

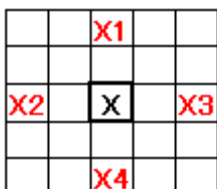

Defective pixel correction function calculates value for X pixel referring to the peripheral pixels (up and down, left and right).  
When all peripheral pixels, shown as X1, X2, X3, and X4, are already registered as defective pixels, user cannot correct the X pixel.

AnalogControl		
DefectPixelCorrection	On/Off	
DefectPixelAdd	(Execute)	
DefectPixelAddOffsetY	0~5119	[Not subject to save]
DefectPixelAddOffsetX	0~5119	[Not subject to save]
DefectPixelDelete	(Execute)	

- DefectPixelCorrection: Enable or disable defective pixel correction function.
- DefectPixelAddOffsetY: Specify Y coordinate.
- DefectPixelAddOffsetX: Specify X coordinate.
- Execute DefectPixelAdd to register the specified coordinates as defective pixels.
- Execute DefectPixelDelete to delete the specified coordinates from registered defective pixels.
- When user specify the same coordinates as those registered at factory, function ignores them.
- DefectPixelDelete command deletes only added pixels by user.
- Data registered at factory is not subject to delete with DefectPixelDelete command.

Updating defective pixel data with detection function

This is for user to detect and register correction data of white defect pixels.

AnalogControl		
DefectDetectionThresholdValue	0~1023	
DefectDetection	(Execute)	
DefectDetectionStatus	(Read Only)	
DefectPixelDefault	(Execute)	
DefectCorrectMode	Reacquire/Add	[Not subject to save]

- DefectDetectionThresholdValue: This is to set a threshold value (0 ~ 1023: 10bit equivalent) for user defective pixel detection. Function registers data with luminance level that exceeds the threshold value specified here. With 8 bit images, specify a value of 4 times of signal level as a threshold value.
- DefectDetection: This is to detect defective pixels. Function automatically registers pixels that exceed the level specified with DefectDetectionThresholdValue. Make sure to shield light from image sensor to execute. Function reflects defective pixel correction registered by user immediately after execution. Execute UserSetSave after DefectDetection to save data into the non-volatile memory.
- DefectDetectionStatus: This is to indicate results of defective pixel detection proceeded by user.

0	No defective pixel correction data registered by user.
Value (1024 or less)	Number of defective pixels detected and registered by user.
[Error code]	
0x000e0001 (917505)	Total number of defective pixel correction data exceeds the maximum number to register. (1024 points)
0x000e0002 (917506)	Total number of defective pixel correction data exceeds the maximum number to register in one CH. (64)

When an error code returns, check if user threshold value (DefectDetectionThresholdValue) is appropriate. Reacquire DefectCorrectMode or execute DefectPixelDelete. Make sure to close lens and change detection conditions (ex. gain or threshold value) to re-execute.

- DefectPixelDefault: This is to delete entire defective pixel correction data registered by user.
- DefectCorrectMode: This is to select detection mode of defective pixels out of the followings.
  - Reacquire mode: This mode deletes defective pixel data except those registered by specifying coordinates and reacquire defective pixels.
  - Add mode: This mode acquires defective pixels in addition to the current pixels registered.

## [Note]

- Make sure to acquire defective pixel correction data when camera is in operation.
- Make sure to turn OFF partial scan to execute defective pixel correction. (Size must be 5120 x 5120 to execute).
- To acquire defective pixel correction data by changing threshold value of DefectDetectionThresholdValue, execute DefectPixelDefault first to delete defective pixel correction data registered by user and reacquire data.
- Maximum number of defective pixels to register and to correct may not always be the same due to following reasons.
  - (1) With white defects detection, if one of the interleave channel reaches the maximum number of defective pixels to register, correction stops. Function registers data up to that point, outputs error, and ends operation.
  - (2) When there is no effective pixel around the pixel to add (on the left, right, top, and bottom), user can register but cannot correct that pixel.

## □ Indication of defective pixel coordinates

This is to indicate the coordinates of registered defective pixels.

AnalogControl		
RegisteredDefectSelector	UserState/InitialState	[Not subject to save]
RegisteredDefectNumber	(Read Only)	
DefectPixelNumber	1~1024/1~1024	[Not subject to save]
DefectPixelOffsetY	(Read Only)	
DefectPixelOffsetX	(Read Only)	
DefectPixelType	(Read Only)	

- RegisteredDefectSelector: Selection of defective pixel data to indicate.
- RegisteredDefectNumber: Defect counts corrected.
- DefectPixelNumber: This is to set a number of the registered defective pixels. Specify Table number of defective pixel data registered at factory and registered by user.
- DefectPixelOffsetY: This is to indicate Y coordinate of the defective pixel specified with DefectPixelNumber. When user specifies a table number with no defective pixel data, it shows 65535.
- DefectPixelOffsetX: This is to indicate X coordinate of the defective pixel specified with DefectPixelNumber. When user specifies a table number with no defective pixel data, it shows 65535.
- DefectPixelType: This is to indicate defect type of the pixel specified with DefectPixelNumber.
  - 1: White defects registered upon shipment from factory
  - 2: Black defects registered upon shipment from factory
  - 6: Defects registered by user
  - 7: Defects additionally registered by user
  - 65535: Table without defects

AnalogControl	
ChannelNumber	1~16 [Not subject to save]
DefectPixelChannelCount	(Read Only)

- ChannelNumber: This is to specify channel number of defective pixel correction.
- DefectPixelChannelCount: Defective pixel count for the channel specified with ChannelNumber.  
Number of types selected with RegisteredDefectSelector.

4.13. Shading Correction

- This is to correct the drop in the amount of peripheral light caused by lens and others.

AnalogControl	
ShadingCorrectionDataSelector	Off/Table1/Table2/Table3
DetectShading	(Execute)

- ShadingCorrectionDataSelector: This is to turn off shading correction function or to select a correction Table.
- Off: Disable shading correction.
- Table1~3: Enable shading correction with selected correction Table.  
\* Enabled only with one partial scan area. (Select one with RegionSelector out of 1~16)
- DetectShading: Select a Table 1-3 and execute function to acquire shading correction data to the selected Table. Partial scan setting must be only one region to set. Turn on RegionMode and set Width and Height to 5120 (Width=Height=5120). Shoot an object with stable brightness such as pattern box to full screen to execute. Execute UserSetSave to save the acquired correction data.

Before shading correction



After shading correction

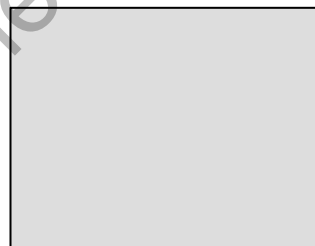

[Note]

- Acquire correction data only when camera is in operation. Acquisition of shading correction data is invalid when there is no output from camera.
- Execute UserSetSave to save the correction data of Table 1~Table 3 into non-volatile memory at one time.
- Correction data is not subject to UserSetLoad for Default.
- With vertical flipping, re-acquire shading correction data.

4.14. Black Level Adjustment

- This is to adjust black level of image sensor.

AnalogControl	
BlackOffset	-1024~1023

[Note]

- This is not adjustment of camera output level.
- User can change setting values while capturing images. However, disturbed images may occur.

#### 4.15. Test Pattern Indication

- This is to display test pattern from camera. This is useful to check if your system is operating properly.

ImageFormatControl	
TestPattern	Off ColorBar

- ※ Displaying test pattern and cursor are mutually exclusive. Gain and gamma correction are not subject to reflect.

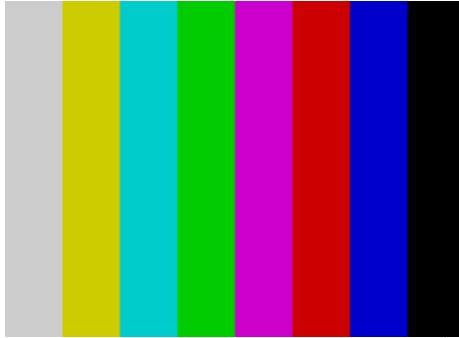

[Note]

- Invalid ReverseX/ReverseY settings.

#### 4.16. Cursor Indication

- This is to show cursor on your display screen.

ImageFormatControl	
CursorPattern	On/Off
CursorOffsetX	0~5119
CursorOffsetY	0~5119
CursorColor	White/Black

- CursorPattern: Cursor indication On/Off.
- CursorOffsetX: X coordinate of vertical cursor.
- CursorOffsetY: Y coordinate of horizontal cursor.
- CursorColor: This is to select the color of cursor (black or white).

[Note]

- With partial scan mode, cursor will be out of view with the following conditions.

$$\text{Height} \leq \text{CursorOffsetY}$$

$$\text{Width} \leq \text{CursorOffsetX}$$

- Color interpolation of frame grabber board may color the cursor.

#### 4.17. LED Operational Mode

- This is to change operational mode of LED at the rear of camera. For information on lighting patterns, refer to Section 3.3.3. LED Indicator.

©2020 - 2024 CIS Corporation. All rights reserved.

DeviceControl	
DeviceIndicatorMode	Active ErrorStatus Inactive

- Active: Indication of communication status of CoaXPress.
- ErrorStatus: OFF with normal operation.  
Lights only with video transmission error or inappropriate trigger input.
- Inactive: ALL LED OFF

#### 4.18. Camera I/O

- According to LineSource settings, camera outputs the following signals through pin No. 6 and 7 of 12pins circular connector.

Digital IO Control (6pin)	
LineSelector	Line1 [Not subject to save]
LineMode	(Read Only) Output
LineSource	OFF ExposureActive FrameActive LineActive TriggerPacketActive

Digital IO Control (7pin)	
LineSelector	Line2 [Not subject to save]
LineMode	(Read Only) Output
LineSource	OFF ExposureActive FrameActive LineActive TriggerPacketActive

- LineSource
  - ExposureActive: This is to indicate exposure period of image sensor with Hi Active.
  - FrameActive: This is to indicate effective period of frame with Hi Active.
  - LineActive: This is to indicate effective period of video output line with Hi active.
  - TriggerPacketActive: This is to decode and output packet signals of uplink trigger from frame grabber.

#### 4.19. User ID

DeviceControl	
DeviceUserID	-

- Set a letter string as DeviceUserID with up to 16 characters excluding terminal NUL letter (¥0). Execute UserSetSave to save these letter strings to camera memory. These data are not subject to "UserSetLoad" with "Default."

#### 4.20. Temperature Indication

- This is to indicate temperature of image sensor (°C).

DeviceControl	
DeviceTemperature	(Read Only)

[Note]

- This is a reference temperature and not the actual temperature.

#### 4.21. White Balance

AnalogControl	
BalanceRatioSelector	Red Blue
BalanceWhiteAuto	Off Once
BalanceRatio	1.00~8.00

- BalanceWhiteAuto: This is to adjust white balance gain automatically.
  - Off: Waiting
  - Once: Adjust white balance automatically with one push.

Select "Once" of BalanceWhiteAuto to adjust white balance once and return to off. BalanceRatio shows new gain of color component selected with BalanceRatioSelector. Shoot an object with achromatic color to full screen to execute BalanceWhiteAuto. Recommendation is approx. 50% of signal level to execute.

※ Set RegionSelector to EffectiveRegion to execute "Once" of BalanceWhiteAuto.

※ More than 2 partial areas disable BalanceWhiteAuto.

Enables the following commands only when BalanceWhiteAuto is OFF.

- BalanceRatioSelector: This is to select the color component you wish to change with BalanceRatio
- BalanceRatio: This is to set gain  $x1 \sim x8$ .

If user set Red with BalanceRatioSelector, set BalanceRatio to 1.0, then change BalanceRatioSelector to Blue, and set BalanceRatio to 1.0, white balance becomes invalid.

## 5. Factory Settings

Function	Data	Explanation
TriggerSelector	AcquisitionStart	Free run mode
TriggerMode	Off	Trigger mode OFF
TriggerSource	LinkTrigger0	UP link trigger
TriggerActivation	RisingEdge	Rising edge
ExposureTime	43947	43.947ms
BalanceWhiteAuto	Off	Waiting
BalanceRatio	1.0	White balance is invalid
Gain	1.00	x1.00
Gamma	1.00	Gamma coefficient=1.00
ShadingCorrectionDataSelector	Off	Shading correction Off
DefectPixelCorrection	On	Defect pixel correction On
DefectivePixelAddOffsetX	0	X coordinate of defective pixel = 0
DefectivePixelAddOffsetY	0	Y coordinate of defective pixel = 0
DefectivePixelThresholdValue	1023	Threshold value of defective pixel detection
BlackOffset	-570	Black level initial value
PixelFormat	BayerGB8	BayerGB 8bit
ConnectionConfig	CXP6_X1	CXP6, 1lane
CxpConnectionTestMode	NormalOperation	Link test Off
RegionSelector	EffectiveRegion	Partial area (ROI) (ON only with Region1)
RegionMode	On	Partial area (ROI) operation ON
Width	5120	Region width = 5120 (Max.)
Height	5120	Region height = 5120 (Max.)
OffsetX	0	Region X offset = 0 (Min.)
OffsetY	0	Region Y offset = 0 (Min.)
TestPattern	Off	Test pattern Off
CursorPattern	Off	Cursor indication Off
CursorOffsetX	2560	Position of cursor X = 2560 (Center)
CursorOffsetY	2560	Position of cursor Y = 2560 (Center)
CursorColor	White	Cursor color is White
DeviceIndicatorMode	Active	CoaXPress communication status
LineSource	Off	Low fix
UserSetSelector	UserSet0	Selectable with initialization
DeviceUserID	"" (Space)	User set letter string (16 letters)

6. Dimensions

6.1. Camera Dimensions (VCC-25CXPHSR-F)

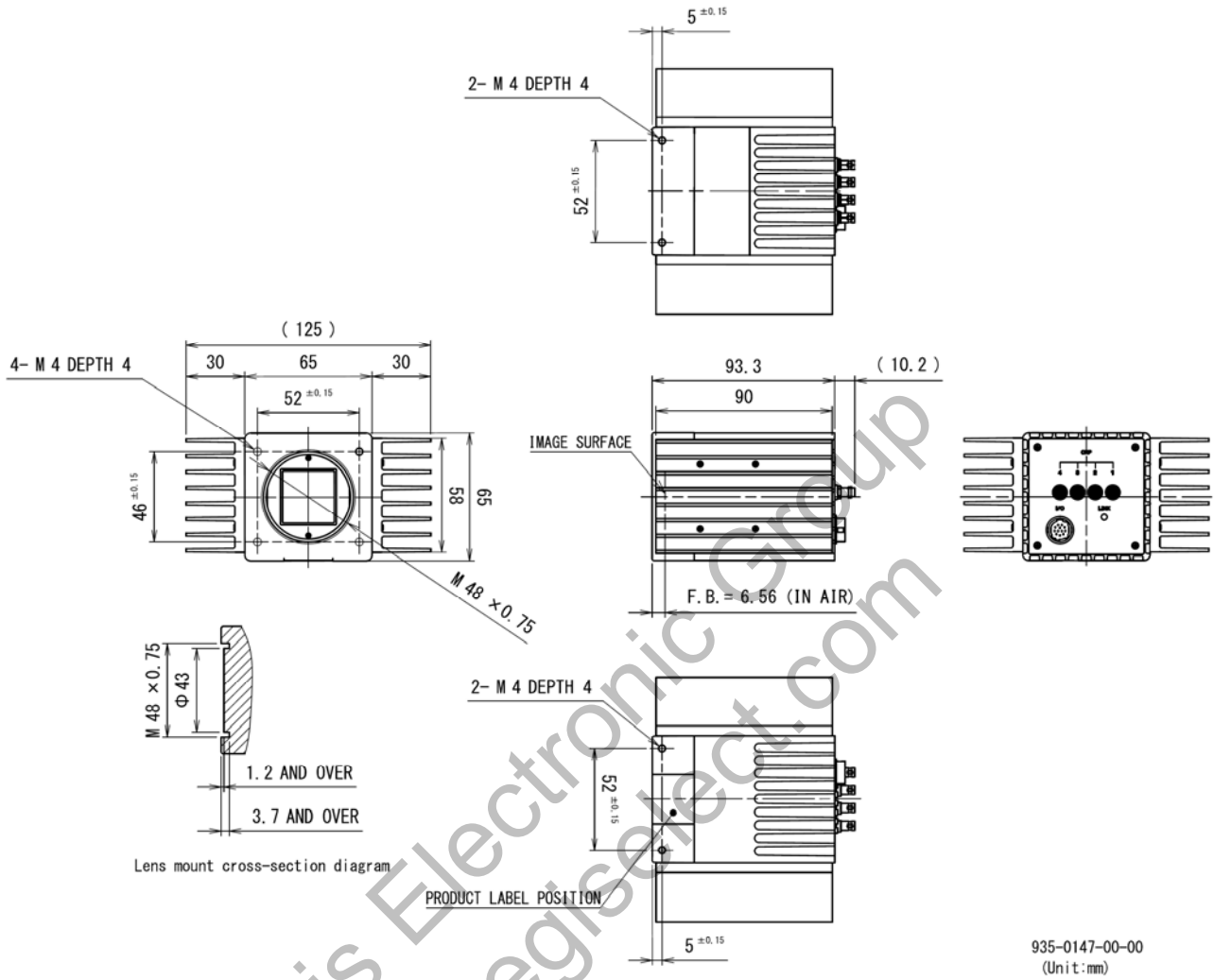

Note 2) Lens mount screw complies with M48 x 0.75-6H. Please refer to J11A LE-004-2011.  
 Note 1) Please make sure the protrusion portion does not interfere with the lens selected.  
 Refer to the lens mount cross-section diagram for the details.

Camera installation and heat dissipation

Comparing the case where the imaging surface is facing downward with the case where the imaging surface is oriented horizontally, the heat dissipation performance of the camera body with a heat sink attached becomes approximately 2°C worse when the imaging surface is horizontally oriented.

When installing the camera horizontally, please consider heat dissipation to a metal plate or similar structure used for mounting the camera (e.g., 100mm[W]x35mm[D]x10mm[H] or more).

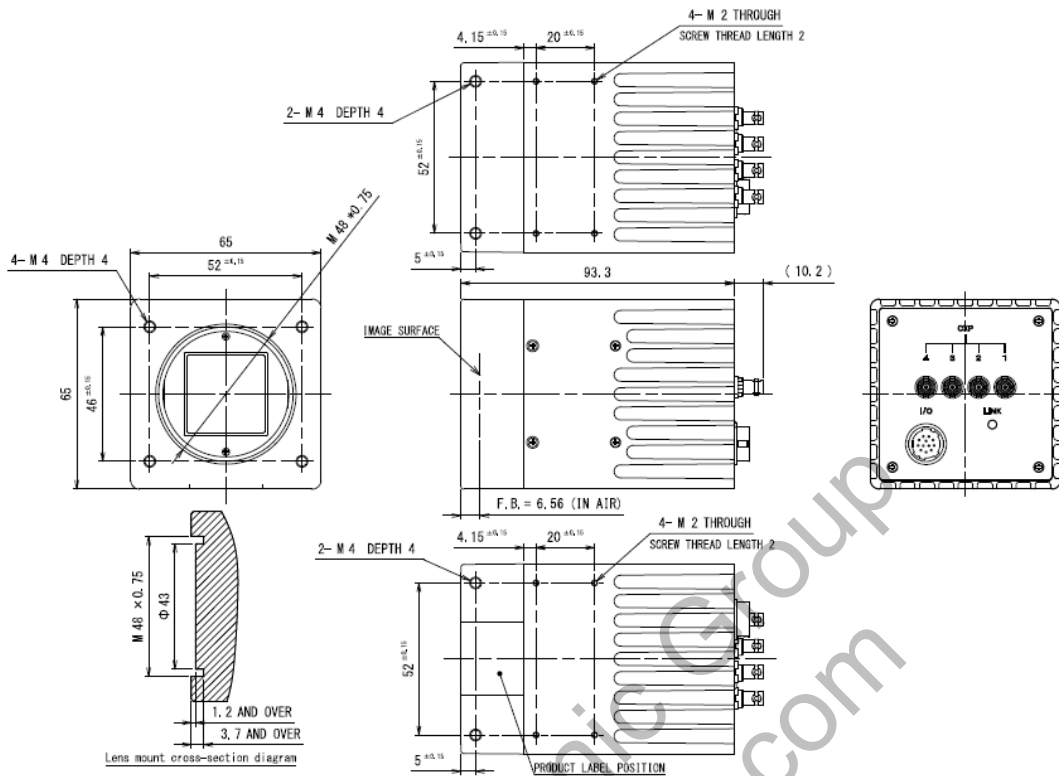

Note 2) Lens mount screw complies with M48×0.75–6H, Please refer to J11A LE-004-2011.  
 Note 1) Please make sure the protrusion portion does not interfere with the lens selected.  
 Refer to the lens mount cross-section diagram for the details.

935-0171-00-00  
 (UNIT:mm)

- Note for camera installation and heat dissipation (When using VCC-25CXPHSR under environment exceeds 35°C) Temperature of the camera top must be less than 60°C. Please make sure to take appropriate heat dissipation measures to use this camera. Insufficient heat dissipation may cause damages or malfunction of the camera. Our warranty does not apply to damages or defects caused by neglecting our instructions and precautions explained in this manual.

Item	Conditions	Reference picture
How to install camera	Fix camera with screws (screw holes M4x4 or M2x8 located at the top and bottom) (Refer to Camera Dimensions)	
Lens	None	
Camera settings	Connection Config: CXP12x4 Pixel Format: Mono8 Trigger Mode: Free run mode (Camera internal trigger) With outputting video.	
Measuring point of temperature	Top, toward rear (Shown red in the picture on the right)	
Material for installation	Black anodized aluminum board	
Size of installation board	290mm×165mm×10mm (Surface area must be more than 101920mm <sup>2</sup> )	
Airflow	Only natural convection	

6.2. Optical Axis Accuracy (VCC-25CXPHSR-F)

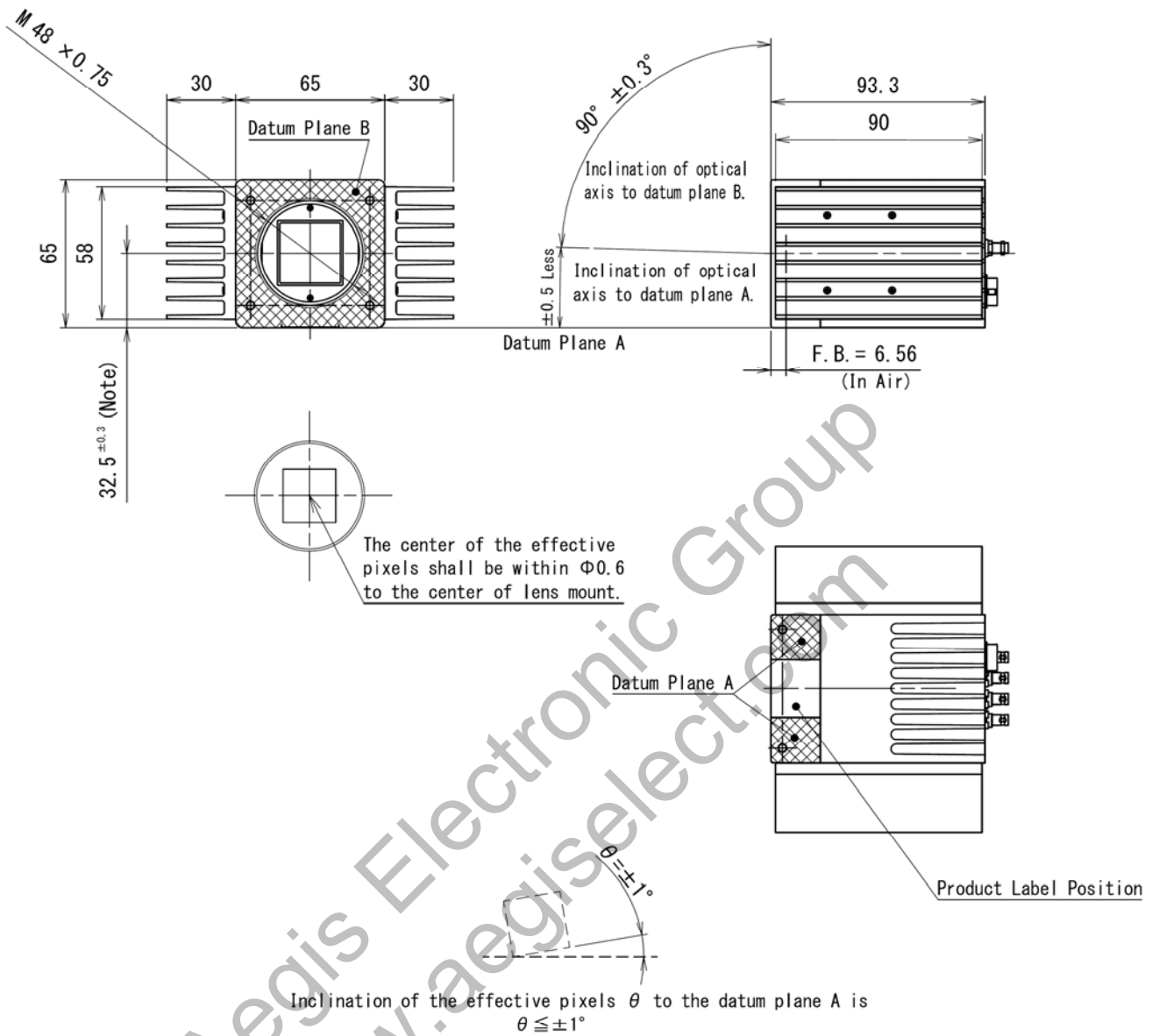

Note: Dimensions from datum plane A to the center of the lens mount.

937-0031-00-00  
(Unit : mm)

6.3. Optical Axis Accuracy (VCC-25CXPHSR)

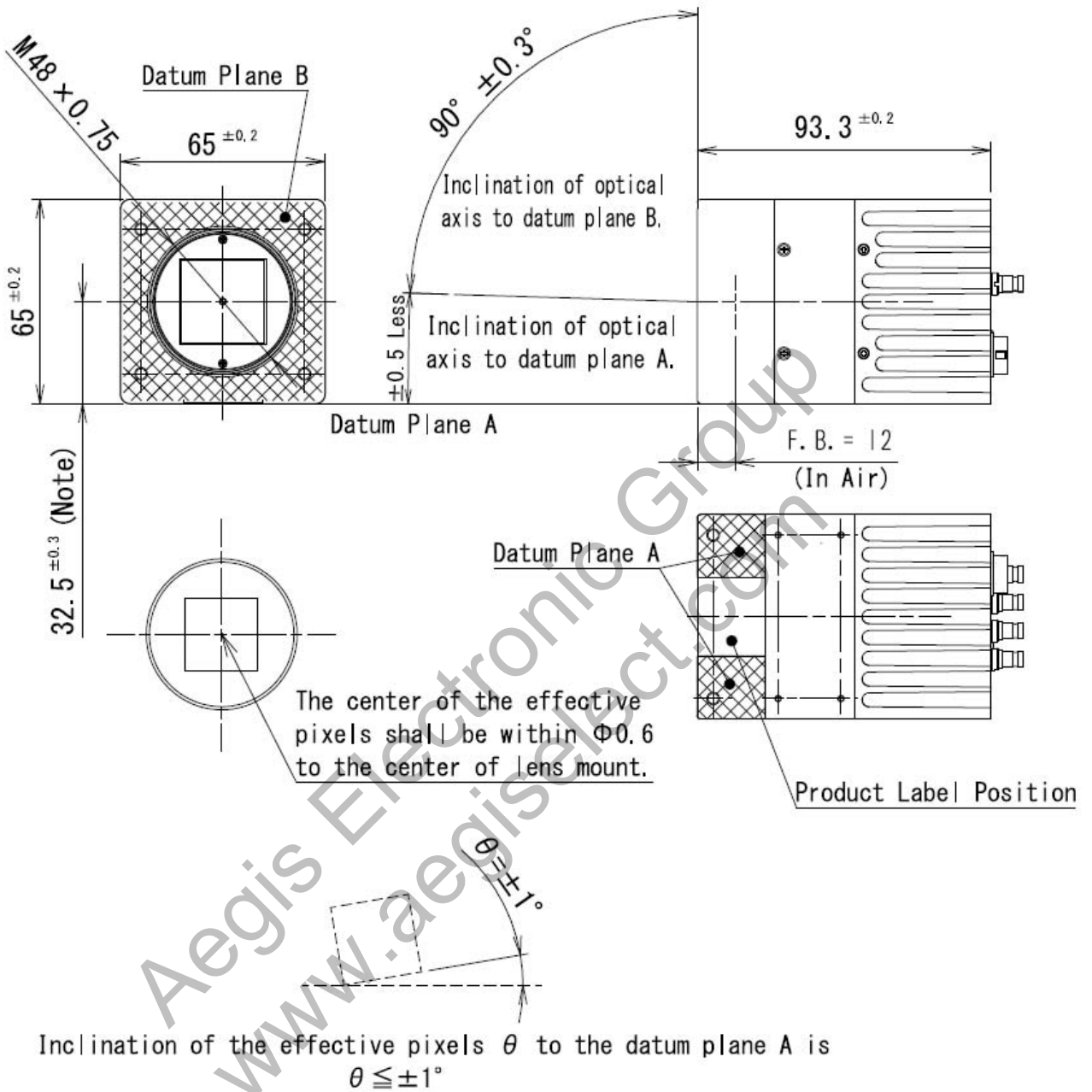

Note : Dimensions from datum plane A to the center of the lens mount.

937-0032-00-00  
(Unit: mm)

## 7. Case for Indemnity (Limited Warranty)

### 7.1. Product Warranty

The term of warranty of this product is within 3 years from the date of shipping out from our factory.

If you use the product properly and discover a defect during the warranty period, and if that was caused by designing or manufacturing, CIS Corporation, at its option, repairs or replaces it at no charge to you. Products out of warranty period will be subject to charge.

CIS should not hold responsible for damages or losses if;

- damages or losses are caused by earthquake, lightning strike, fire, flood or other acts of God.
- damages or losses are caused by deliberate or accidental misuse by user, or failure to observe the information contained in the instructions in this Product Specification and Operational Manual.
- damages or losses are caused by repair or modification conducted by customer or any unauthorized party.

### 7.2. CMOS Defective Pixels

CIS applies defective pixel correction prior to shipment of the product. However, the number of defective pixels is subject to increase due primarily to the effect of cosmic rays. Due to this nature, CIS should not hold responsible for the natural increase of defective pixels.

Pixel defects outside of Area B (5060x5060 pixels) shown in the figure below are not considered.

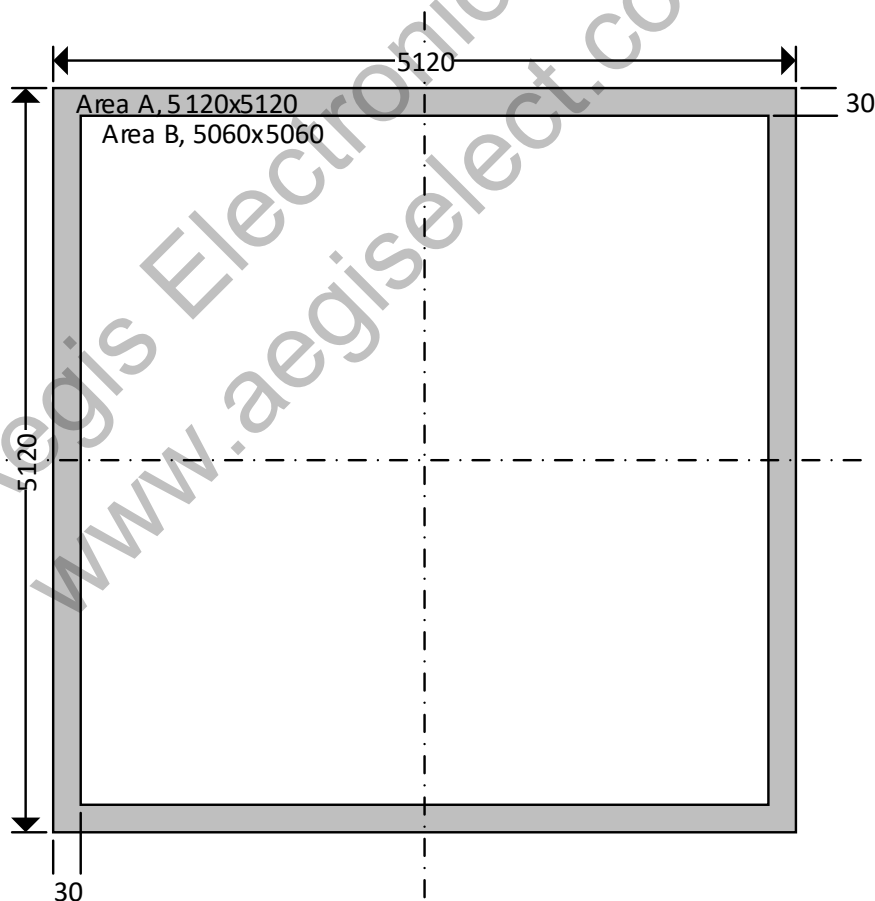

### 7.3. Product Support

Should you have any problems in function of the product you purchased, and if you need our further analysis and/or repair, please contact your local distributor