

---

# CIS

**CoaXPress I/F  
24M pixels CMOS (B/W) Camera**

# VCC-24CXP7M

**Product Specifications  
& Operational Manual**

**CIS Corporation**

## Table of Contents

1.	Handling Precautions .....	1
1.1.	Camera Handling Precautions.....	1
1.2.	Restrictions on Applications.....	1
1.3.	Disclaimers (Exception Clause).....	1
2.	Product Outline .....	2
2.1.	Features.....	2
2.2.	Configuration.....	2
3.	Specifications.....	3
3.1.	General Specifications.....	3
3.2.	Input and Output Specifications .....	4
3.2.1	TRIGGER_IN Input (6pins circular connector, No.5 pin) .....	4
3.2.2	SIGNAL_OUT Output (6pins circular connector, No.3 pin) .....	4
3.3.	External Connector Pin Assignment.....	5
3.3.1	6pins Circular Connector.....	5
3.3.2	75Ω BNC Connector .....	5
3.3.3	LED Indicator .....	5
3.4.	Spectral Response.....	6
3.5.	Output Timing .....	6
3.5.1	Horizontal Sync Timing.....	6
3.5.2	Vertical Sync Timing.....	8
4.	Camera Function .....	9
4.1.	Camera Interface .....	9
4.2.	How to Save and Initialize Settings.....	9
4.3.	Link Speed and Link Count.....	9
4.4.	Pixel Format .....	10
4.5.	Flipping.....	10
4.6.	Internal Sync Mode (Free Run Mode).....	10
4.7.	External Trigger Sync Mode.....	11
4.8.	Trigger Sync Mode and Delay Time to Start Exposure .....	12
4.9.	Delay Time to Readout .....	13
4.10.	Restrictions on Trigger Pulse Input Timing.....	13
4.11.	Fixed Trigger Shutter Mode (LineSync) H Sync Trigger.....	14
4.12.	FAST Fixed Trigger Shutter Mode (ClockSync) CLK Sync Trigger.....	15
4.13.	Pulse Width Trigger Shutter Mode (LineSync) H Sync Trigger .....	16
4.14.	FAST Pulse Width Trigger Shutter Mode (ClockSync) CLK Sync Trigger .....	17
4.15.	Exposure Time.....	18
4.16.	Formula to Calculate Manual Shutter Values with H Sync Mode.....	19
4.17.	Manual Shutter Settings with CLK Sync Mode (FAST Trigger Mode).....	19
4.18.	Gain.....	19
4.19.	Gamma Correction .....	19
4.20.	Black Level Adjustment.....	20
4.21.	Partial Scan (ROI) .....	20
4.22.	Image Quality Selecting Mode .....	21
4.23.	Shading Correction.....	21
4.24.	Impulse Noise Removal Filter .....	22
4.25.	Defective Pixel Correction .....	23
4.26.	Test Pattern Indication.....	27
4.27.	Cursor Indication .....	27

---

4.28.	LED Operational Mode .....	27
4.29.	Camera Timing Output .....	28
4.30.	User ID .....	28
4.31.	Temperature Indication.....	28
5.	Factory Settings .....	29
6.	Dimensions.....	31
6.1.	Camera Dimensions.....	31
6.2.	Optical Axis Accuracy.....	32
7.	Case for Indemnity (Limited Warranty).....	33
7.1.	Product Warranty .....	33
7.2.	CMOS Defective Pixels .....	33
7.3.	Product Support.....	33

Aegis Electronic Group  
www.aegiselect.com

## 1. Handling Precautions

### 1.1. Camera Handling Precautions

- Do not use or store camera in dusty or humid places.
- Do not apply excessive force, vibration, or static electricity that could damage camera. Please handle camera with care.
- Do not shoot direct images that are extremely bright (e.g., strong light source, sun, etc.). When extremely strong light source is shot, smear or blooming may occur. Put the lens cap on when camera is not in use.
- Follow the instructions in [Section 3.3., "External Connector Pin Assignment"](#) for connecting camera. Improper connection may cause damages not only to the camera but also to the connected devices.
- Confirm mutual ground potential carefully before connecting camera to monitors or computers. Any AC leak from the connected devices may cause damages or destroy the camera.
- Do not apply excessive voltage. (Use only the specified voltage.) Unstable or improper power supply voltage may cause damages or malfunction of the camera.
- The temperature of this model "VCC-24CXP7M" becomes high due to its small camera chassis. We recommend you to use this model by attaching the camera to a metal plate for the purpose of heat dissipation.
- Our warranty does not apply to damages or defects caused by irregular and/or abnormal use of the product.

**Our warranty does not apply to damages or defects caused by neglecting the instructions and precautions explained in this manual.**

### 1.2. Restrictions on Applications

- The camera must not be used for any nuclear equipment or aerospace equipment with which mechanical failure or malfunction could result in serious bodily injury or loss of human life.
- The camera must not be used under conditions or environments other than those specified in this manual.

### 1.3. Disclaimers (Exception Clause)

CIS should not be liable for any damages or losses if;

- damages or losses are caused by earthquake, lightning strike, fire, flood, or other acts of God.
- damages or losses are caused by deliberate or accidental misuse by user, or failure to observe information and instructions explained in this manual.
- damages or losses are caused by repair or modification conducted by user or any unauthorized party.

## 2. Product Outline

VCC-24CXP7M is B/W camera with CoaXPress interface. Using 1.2", global shutter type 24M pixels CMOS image sensor.

### 2.1. Features

- Dimensions: 29mm(H) x 29mm(W) x 55mm(D)
- Global shutter type CMOS sensor (Monochrome)
- Complies with CoaXPress CXP-3 and CXP-6
- Supports 1 lane
- Maximum cable length: Approximately 100m (when CXP-3), approximately 40m (when CXP-6)
- ROI
- Exposure setting, Gain setting
- External trigger mode (Fixed trigger shutter mode/Pulse width trigger shutter mode)
- Complies with GenICam
- C mount

### 2.2. Configuration

- Standard configuration
  - Camera VCC-24CXP7M

Aegis Electronic Group  
www.aegiselect.com

## 3. Specifications

## 3.1. General Specifications

<b>Electrical Specifications</b>			
Image sensor	Sensor type	1.2", Global shutter type CMOS sensor	
	Effective pixels	5328(H) × 4608(V)	
	Unit cell size	2.74μm(H) × 2.74μm(V)	
Interface		Complies with CoaXPress ver. 1.1.1. Supports CXP6_x1 and CXP3_x1	
Video output frequency	Pixel clock frequency	74.25MHz	
Video output format		Mono 8 / Mono 10 / Mono 12	
Frame rate	CXP3 8bit/10bit/12bit	11.1fps / 8.9fps / 7.4fps	
	CXP6 8bit/10bit/12bit	21.9fps / 17.6fps / 14.7fps	
Sync. system		Internal sync.	
Resolution (maximum resolution)		5328 (H) × 4608(V)	
Video signals (Gain 0dB)	White clip level	255	with MONO 8bit
	Set up level	0~2	with MONO 8bit
	Dark shading	4 or less (H/V)	with MONO 8bit
Sensitivity		F11 400lx (Shutter speed 1/30s, Gain 0dB, 8bit) F5.6 400lx (Shutter speed 1/30s, Gain 0dB, 10/12bit)	
Minimum illumination		F1.4 0.8lx (Shutter speed 1/30s, Gain +18dB, level=50%, 8bit) F1.4 4lx (Shutter speed 1/30s, Gain +18dB, level=50%, 10/12bit)	
Gain variable range		x1 ~ x64 (0dB ~ +36dB) [Guarantee range]	
Shutter speed		Manual setting	
Gamma correction		Valid (Coefficients from 0.10 ~ 1.80 can be set.)	
Trigger mode		Free run mode (Camera internal trigger) Trigger mode (Host, External terminal) <ul style="list-style-type: none"> <li>• Fixed trigger shutter</li> <li>• Pulse width trigger shutter</li> </ul>	
Partial scan		H/V 1 area can be set.	
Power requirements		PoCXP: 18.5V ~ 26V	
Power consumption		4.0W (CXP-3), 4.3W (CXP-6) [with free run]	
<b>Mechanical Specifications</b>			
Dimensions		H:29mm W:29mm D:55mm excluding projection.	
Weight		Approx. 70g	
Lens mount		C mount	
<b>Environmental Specifications</b>			
Safety/Quality standard		CE: EMC: 2014/30/EU Emission: EN61000-6-4:2007+A1:2011 Immunity: EN61000-6-2:2019 IEC61000-4-5 (surge) is not applicable, so if the cable is longer than 30m or is installed outdoors, use a surge protector to prevent surges from entering.  RoHS: 2011/65/EU (EU)2015/863 EN50581(RoHS2) Conform to KC.	

Durability	Vibration	Acceleration	: 98m/s <sup>2</sup> (10G)
		Frequency	: 20 ~ 200Hz
		Direction	: X, Y, and Z 3 directions
		Testing time	: 120min each
	Shock	No malfunction with 980m/s <sup>2</sup> (100) G for ±X, ±Y, and ±Z, 6 directions without packaging.	
Operational temperature		0 ~ +45°C Humidity: 20 ~ 80%RH with no condensation.	
Storage temperature		-25 ~ +60°C Humidity: 20 ~ 80%RH with no condensation.	

3.2. Input and Output Specifications

3.2.1 TRIGGER\_IN Input (6pins circular connector, No.5 pin)

- 5.0V, 3.3V CMOS level/TTL level
- Input voltage Low: 0.5Vdc (Max), High: 2.1Vdc (Min)
- Triggers can be input directly from the external equipment. Set TriggerSource of AcquisitionControl to Line0 to use this terminal.

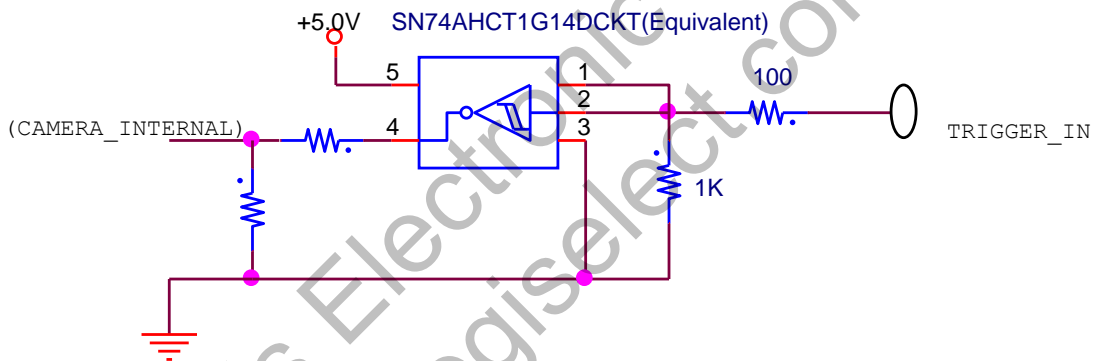

3.2.2 SIGNAL\_OUT Output (6pins circular connector, No.3 pin)

- 5.0V CMOS logic level output
- Output voltage Low: 0.35Vdc (Max.), High: 4.5Vdc (Min.)
- Timing signal in the camera can be output. Set signal to output with LineSource of DigitalIOControl.

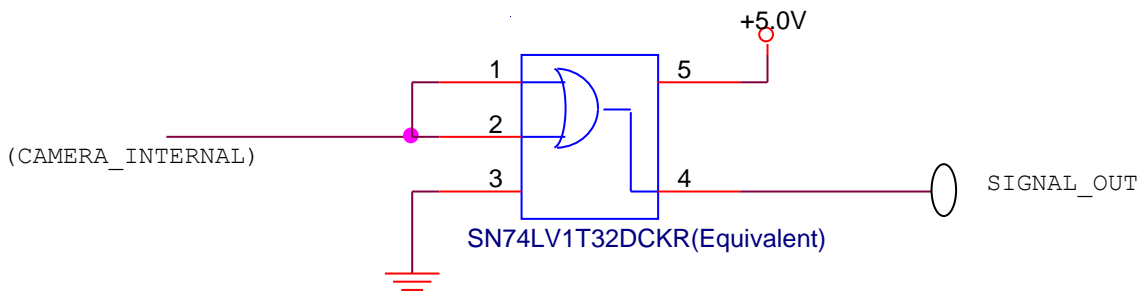

### 3.3. External Connector Pin Assignment

#### 3.3.1 6pins Circular Connector

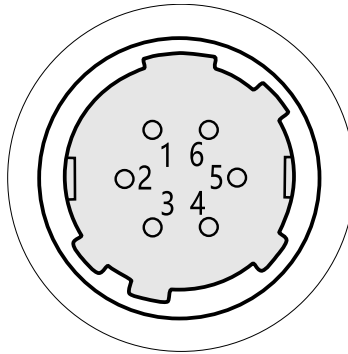

HR10-7R-6PA (Hirose) or equivalent

Pin No.	Signals	Descriptions
1	NC	
2	NC	
3	SIGNAL_OUT	Select either Exposure/FVAL/LVAL/LinkTrigger to output
4	NC	
5	TRIGGER_IN	Trigger input
6	GND	Electrically connected with camera chassis.

※ Non-Connection. Do not connect anything to the terminal.

#### 3.3.2 75Ω BNC Connector

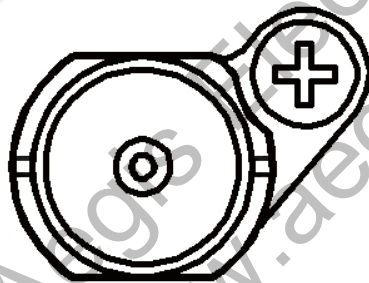

(BCJ-BPLHA CANARE)

#### 3.3.3 LED Indicator

With LED indicator Active, lighting patterns show the camera status by its way of lighting.

OFF	No power supply.
Green lighting	Completion of connection between device and host.
Green fast blinking [12.5Hz]	Transmitting video data.
Orange slow blinking [1Hz]	Waiting for a trigger input.
Red fast blinking [12.5Hz]	System error / trigger error occurred.

3.4. Spectral Response

※ Excludes characteristics of lens, IR cut filter, and light source.

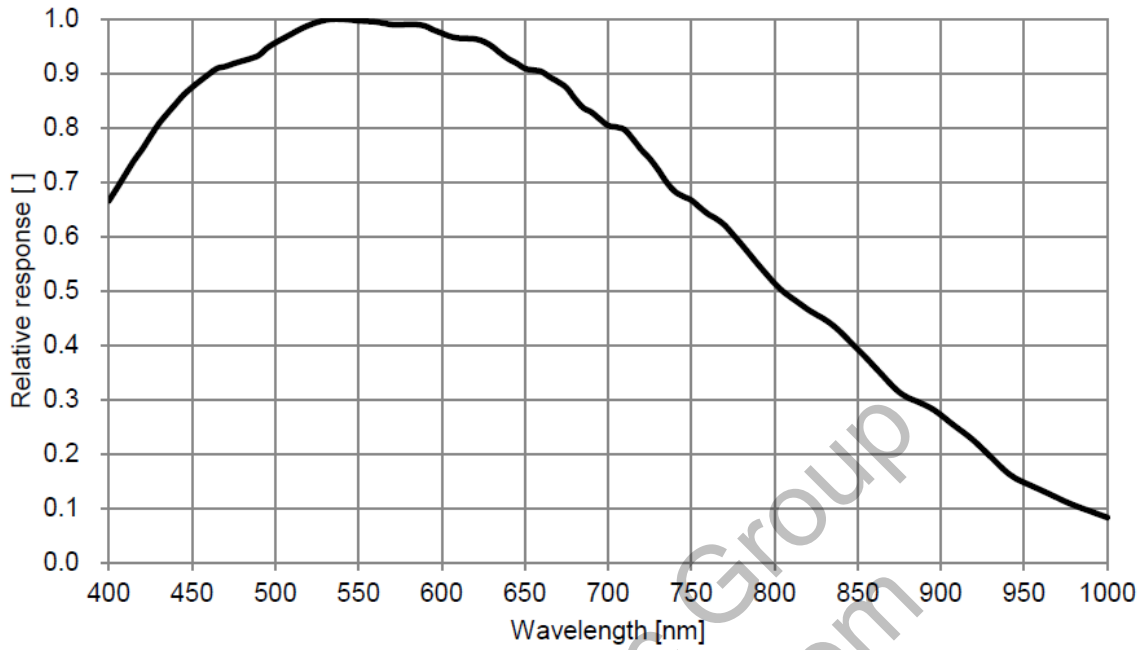

3.5. Output Timing

3.5.1 Horizontal Sync Timing

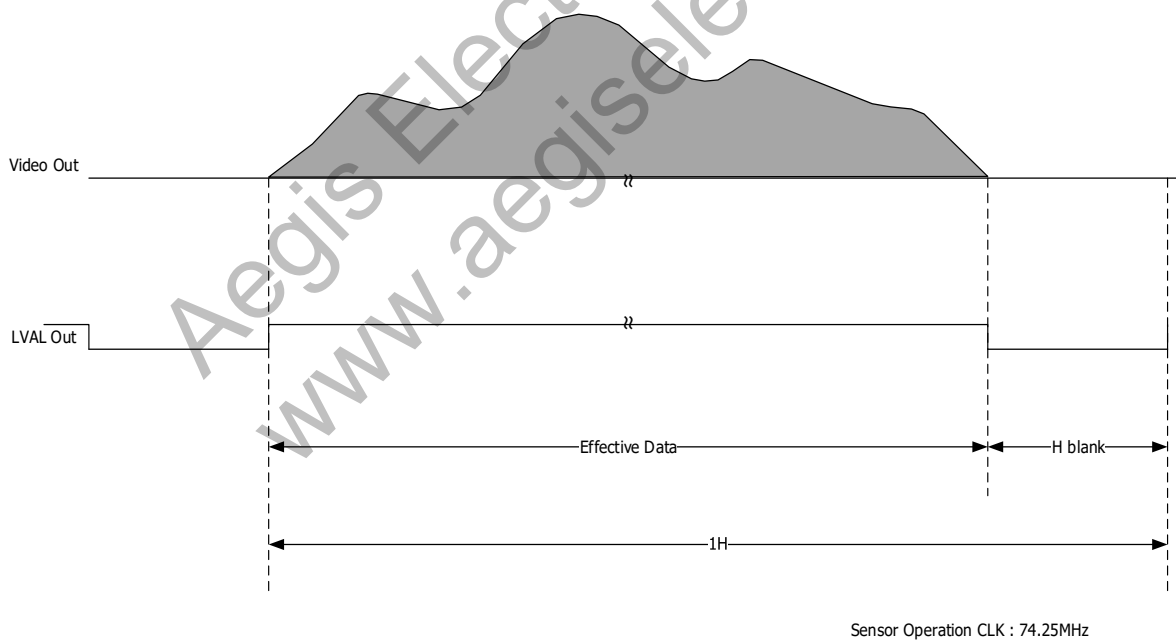

※ The time for 1H will change depends on video output format.

※ The blanking pixel number for 1H will change depends on video output format.

Effective pixel numbers and blanking pixel numbers (Free run/LineSync)

Link rate	Video output format	Effective Data / 8ch	H Blank / 8ch	1H total pixel numbers / 8ch	Time for 1H [us]
CXP-3	Mono8	666	741	1407	18.949
	Mono10	666	1093	1759	23.690
	Mono12	666	1444	2110	28.417
CXP-6	Mono8	666	51	717	9.656
	Mono10	666	227	893	12.026
	Mono12	666	402	1068	14.383

Effective pixel numbers and blanking pixel numbers (ClockSync)

Link rate	Video output format	Effective Data / 8ch	H Blank / 8ch	1H total pixel numbers / 8ch	Time for 1H [us]
CXP-3	Mono8	666	740	1406	18.936
	Mono10	666	1092	1758	23.677
	Mono12	666	1443	2109	28.404
CXP-6	Mono8	666	50	716	9.643
	Mono10	666	226	892	12.013
	Mono12	666	401	1067	14.370

Sensor Operation CLK = 74.25MHz

3.5.2 Vertical Sync Timing

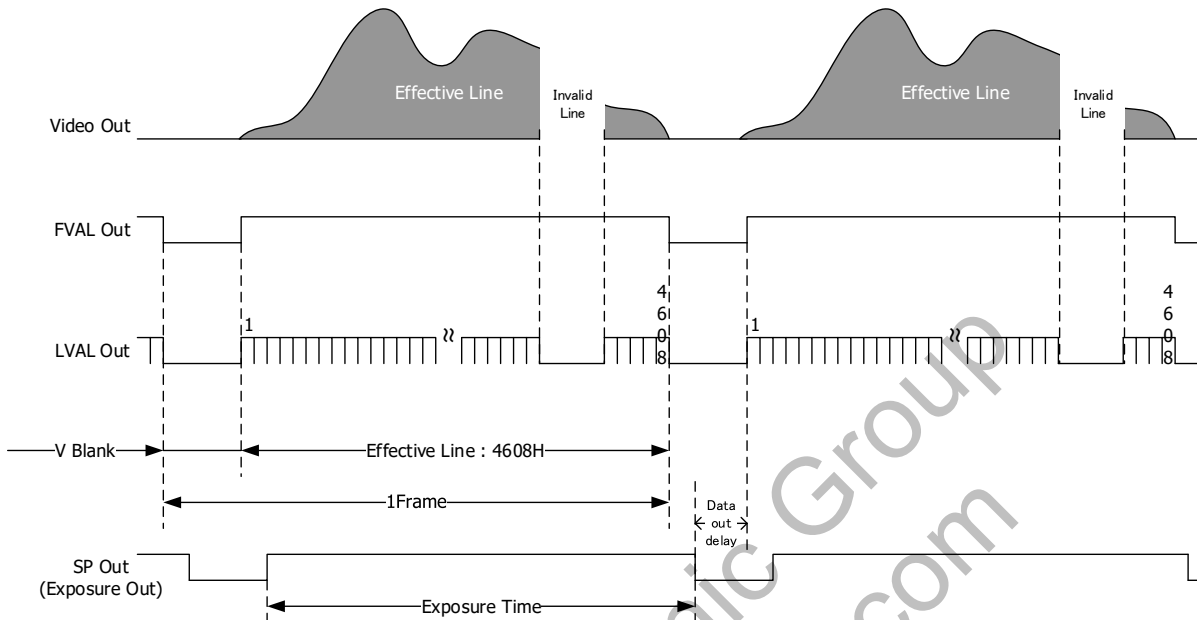

※ The time for 1 frame will change depends on video output format.

※ Please refer to [Section 4.9 Delay Time to Readout](#).

Effective line numbers and blanking line numbers

Link rate	Video output format	Effective line	Invalid line	V Blank	1 frame total line number	Time for 1 frame [ms]
CXP-3	Mono8	4608	10	108	4716	89.3
	Mono10	4608	8	106	4714	111.6
	Mono12	4608	6	100	4708	133.7
CXP-6	Mono8	4608	10	108	4716	45.5
	Mono10	4608	8	106	4714	56.6
	Mono12	4608	6	100	4708	67.7

Sensor Operation CLK = 74.25MHz



4.4. Pixel Format

ImageFormatControl	
PixelFormat	MONO8 MONO10 MONO12

- MONO8 : Monochrome 8bit
- MONO10 : Monochrome 10bit
- MONO12 : Monochrome 12bit

※ Do not change PixelFormat while grabbing (acquiring images).

4.5. Flipping

ImageFormatControl	
ReverseX	True/False

- ReverseX: Flip the image of X direction.

※ Do not change True/False while grabbing (acquiring images).

4.6. Internal Sync Mode (Free Run Mode)

- This is a mode to use internal triggers continuously generated.
- Turn off TriggerMode and set TriggerSelector to AcquisitionStart.
- The table below shows frame rate when ROI is disabled.

PixelFormat	CXP6_X1	CXP3_X1
Mono8	21.9	11.1
Mono10	17.6	8.9
Mono12	14.7	7.4

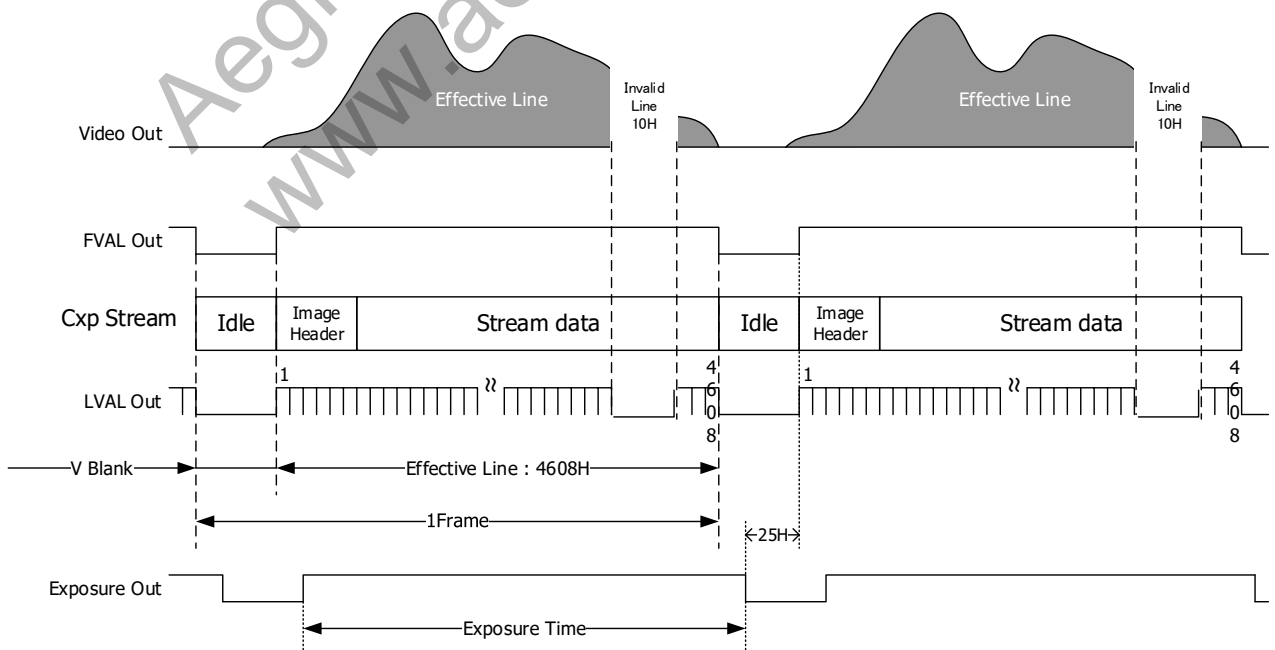

Vertical sync timing (with free run mode) TriggerMode=Off PixelFormat=Mono8

## 4.7. External Trigger Sync Mode

- This is a mode to input external trigger signals to capture images by any preferred timings.
- Set TriggerSelector to FrameStart or TriggerMode to On, and set TriggerSource to either Software, LinkTrigger0, or Line0.

<b>AcquisitionControl</b>	
TriggerMode	On/Off
TriggerSyncMode	LineSync ClockSync
TriggerSelector	AcquisitionStart FrameStart
TriggerActivation	RisingEdge FallingEdge LevelHigh LevelLow
TriggerSource	Software LinkTrigger0 Line0
TriggerSoftware	Execute

- TriggerMode (Link with TriggerSelector)
    - Off: Free run mode (TriggerSelector = AcquisitionStart)
    - On: External trigger mode (TriggerSelector = FrameStart)
    - ※Do not change Trigger Mode while grabbing (acquiring) images.
  - TriggerSelector (Link with TriggerMode)
    - AcquisitionStart: Free run mode (TriggerMode = Off)
    - FrameStart: External trigger mode (TriggerMode = On)
    - ※Do not change TriggerSelector while grabbing (acquiring) images.
  - TriggerSyncMode
    - LineSync: H sync trigger mode (Control exposure time per line)  
Fixed/Pulse width trigger shutter mode  
Overlapping operation (exposure while readout images) is valid.
    - ClockSync: CLK sync trigger mode (Control exposure time per sensor clock)  
FAST fixed/FAST pulse width trigger shutter mode  
Overlapping operation (exposure while readout images) is invalid.
- ※Switch TriggerSyncMode when there is no trigger input.
- ※Set free run mode (internal sync) after set to LineSync mode.

- TriggerSource (Select where to input external triggers)
  - LinkTrigger0: External trigger input from CoaXPress host device.  
Please refer to specification manuals of the host device such as frame grabber board to know how to generate triggers.
  - Line0: External trigger input from 6pins circular connector.
  - Software: TriggerSoftware
  
- ※ Set TriggerSelector to FrameStart or set TriggerMode to On to proceed further settings.
- ※ Software Trigger is valid when TriggerActivation is Rising Edge.
  
- TriggerSoftware: Software trigger
  - Camera generates a trigger to capture one frame image by executing this command.
  - Make sure to set TriggerSource to Software.
  - ※ Software Trigger is valid when TriggerSource is Software.
  
- TriggerActivation
  - This is to select how to start capturing video or its polarity out of the followings.
  - RisingEdge : Fixed trigger shutter mode: Rising edge (Timed)
  - FallingEdge : Fixed trigger shutter mode: Falling edge (Timed)
  - LevelHigh : Pulse width trigger shutter mode: High active (TriggerWidth)
  - LevelLow : Pulse width trigger shutter mode: Low active (TriggerWidth)

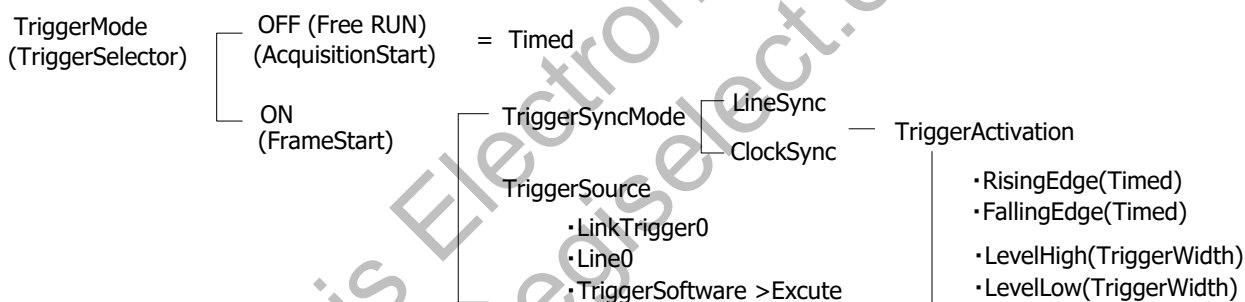

4.8. Trigger Sync Mode and Delay Time to Start Exposure

- H sync trigger mode (LineSync):
  - 1H of jitter may occur from inputting trigger to exposure. (Overlapping operation is valid.)
- CLK sync trigger mode (ClockSync):
  - Less delay time from trigger input, and the precise trigger operation is valid. (Overlapping operation is invalid.)

	PixelFormat	CXP6_X1 CXP3_X1
Delay time to start exposure with H sync trigger (LineSync)	Mono8	Approx. 8H ~ 9H
	Mono10	Approx. 8H ~ 9H
	Mono12	Approx. 6H ~ 7H
Delay time to start exposure with CLK sync trigger (ClockSync)	Mono8	Approx. 0.1us
	Mono10	Approx. 0.1us
	Mono12	Approx. 0.1us

4.9. Delay Time to Readout

	PixelFormat	CXP6_X1 CXP3_X1
Delay time to readout with H sync trigger (LineSync)	Mono8	21H
	Mono10	21H
	Mono12	19H
Delay time to readout with CLK sync trigger (ClockSync)	Mono8	17H
	Mono10	17H
	Mono12	15H

4.10. Restrictions on Trigger Pulse Input Timing

- User can input a trigger for the next frame while camera is reading out signals. However, do not input a trigger pulse to end exposure while camera is reading out signals. In other words, a trigger pulse to start reading out signals for the next frame before completion of reading out signals for the prior frame is restricted.

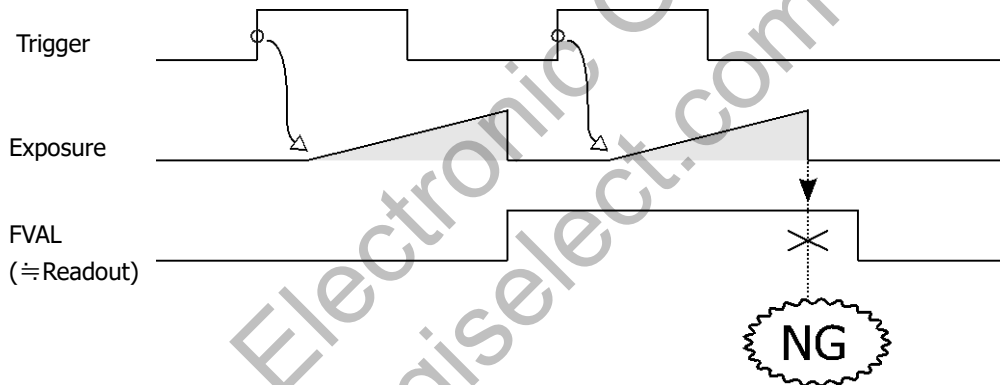

- If there is a trigger input with restricted timing as explained earlier, "IllegalTriggerFlag" becomes "1".

AcquisitionControl	
IllegalTriggerFlag	0 or 1

DeviceControl	
ErrorFlagReset	Execute

This is to reset IllegalTriggerFlag to "0".

4.11. Fixed Trigger Shutter Mode (LineSync) H Sync Trigger

(TriggerMode=On, TriggerSyncMode=LineSync, TriggerActivation= RisingEdge)

- This is a mode to start exposure with external trigger input and expose for a set period.
- Trigger operation is H sync V sync reset.

The delay time (Exposure Time Delay) from detecting trigger edge in the camera to starting exposure:

Video output format	Exposure time delay
Mono8	8H ~ 9H
Mono10	8H ~ 9H
Mono12	6H ~ 7H

1H jitter will occur to Exposure time delay since external trigger signal synchronizes with H inside the camera.

Trigger pulse width to input must be longer than 1H. (Please refer to the time for 1H in the table in [Section 3.5.1.](#))

- Exposure Out shows the exposure period.

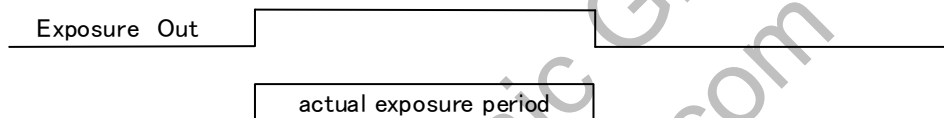

- The next trigger input while outputting images cannot be accepted.
- However, do not input a trigger signal to start outputting next images before completion of outputting the prior images.
- Trigger input while exposure period (Exposure Time) will be ignored in the camera. ((A) in the drawing below.)  
Do not use a trigger shorter than 1 frame cycle.

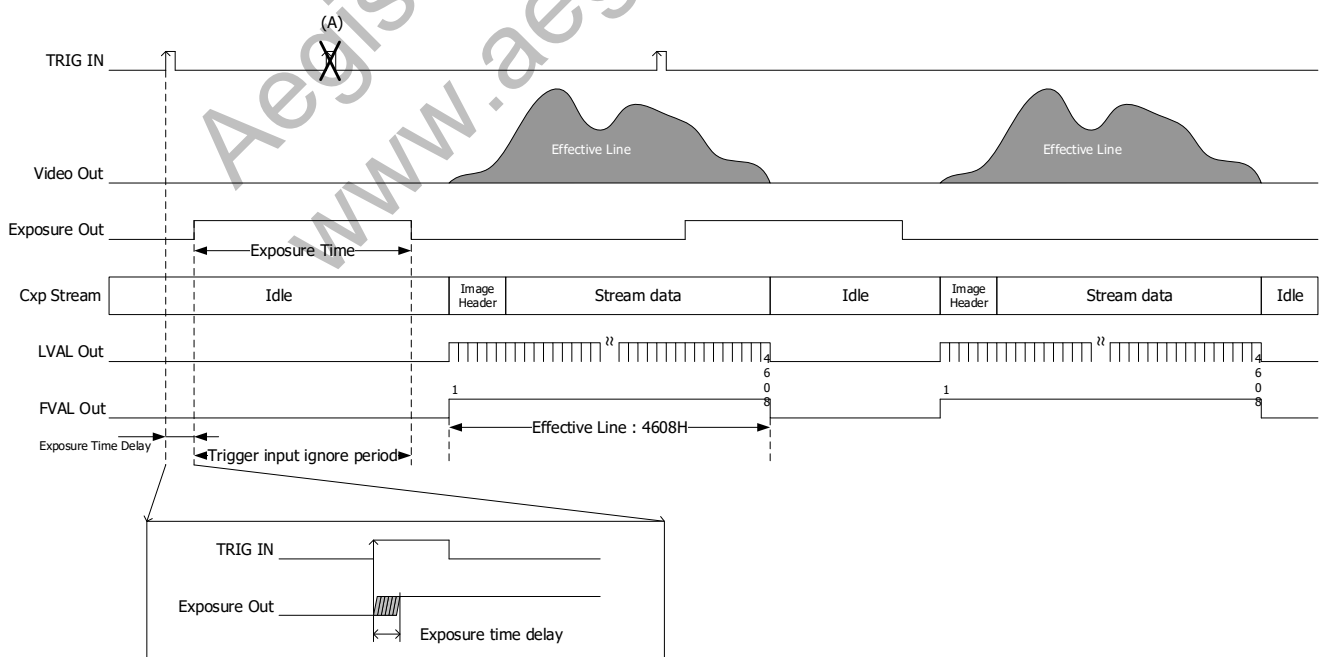

4.12. FAST Fixed Trigger Shutter Mode (ClockSync) CLK Sync Trigger

(TriggerMode=On, TriggerSyncMode=ClockSync, TriggerActivation=RisingEdge)

- This is a mode to start exposure with external trigger input and expose for a set period.
- Trigger operation is CLK sync V sync reset.

The delay time (Exposure Time Delay) from detecting trigger edge in the camera to starting exposure is approx. 0.1 $\mu$ s.

Trigger pulse width to input must be longer than 1 $\mu$ s.

- Exposure Out shows the exposure period.

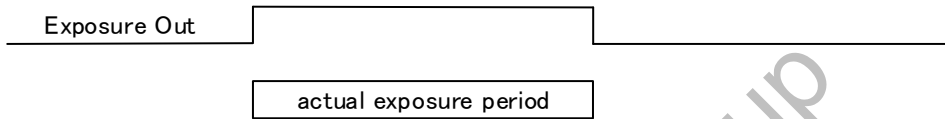

- The next trigger input while outputting images cannot be accepted.
- Trigger input while exposure period (Exposure Time) and readout period will be ignored in the camera. ((A) and (B) in the drawing below)

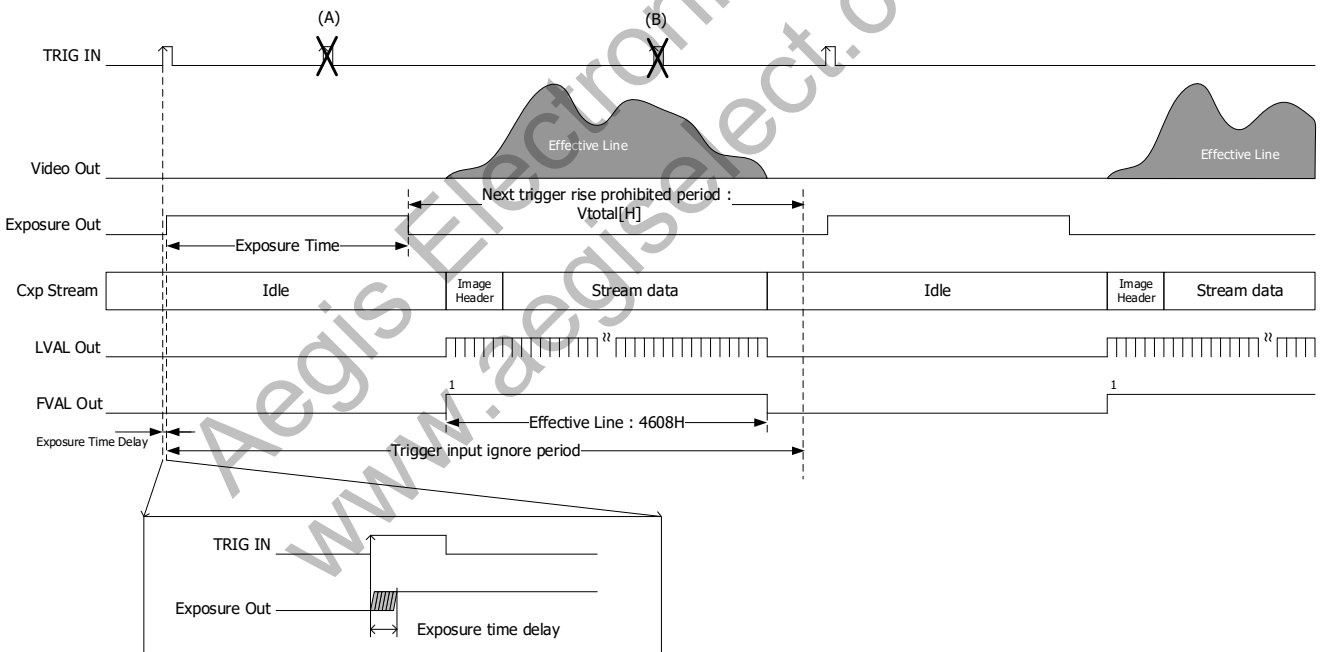

4.13. Pulse Width Trigger Shutter Mode (LineSync) H Sync Trigger

(TriggerMode=On, TriggerSyncMode=LineSync, TriggerActivation=LevelHigh)

- This is a mode to start exposure with external trigger input and set exposure time with pulse width of trigger signals.
- Trigger operation is H sync V sync reset.

Please refer to the following table for the delay time (Exposure Time Delay①) from detecting trigger edge in the camera to starting exposure.

Video output format	Exposure Time Delay①
Mono8	8H ~ 9H
Mono10	8H ~ 9H
Mono12	6H ~ 7H

The delay time (Exposure Time Delay②) from detecting trigger edge in the camera to end exposure

Video output format	Exposure Time Delay①
Mono8	8H~9H + 2.46us
Mono10	8H~9H + 2.46us
Mono12	6H~7H + 2.46us

- Approx. 1H jitter will occur to Exposure Time Delay ① and ② since external trigger signal synchronizes with H inside the camera. Jitters may occur at both start and end edges of exposure with pulse width trigger shutter mode.  
At this time, exposure time will change so that flicker may be shown in the image, especially when high speed shutter is set. This flicker sometimes can be eliminated with fixed trigger shutter mode. However, this problem can be solved by inputting trigger pulse with synchronizing it to the camera H cycle (LVAL).
- Pulse width 1H (Min.) ~ Approx. 2 frames  
Functionally, there is no upper limitation, but noises such as dark noise shadings may be noticeable at long time exposure.
- Exposure Out shows the exposure period.

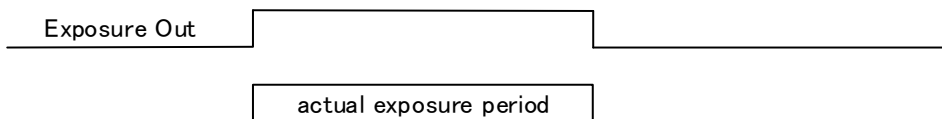

- Trigger input while exposure period (Exposure Time) will be ignored in the camera. Do not use a trigger shorter than 1 frame cycle.

- User can input a trigger while camera is outputting images.

However, do not input a trigger signal to start outputting next images before completion of outputting the prior images. ((A) in the drawing below)

[Note]

- ※ When stop grabbing, (A) in the drawing below may occur depending on the grabber board to use.
- ※ When change exposure time while grabbing, (A) in the drawing below may occur depending on the grabber board to use.
- ※ When illegal triggers described above occurred, LED will become red blinking. User can clear this with ErrorFlagReset.

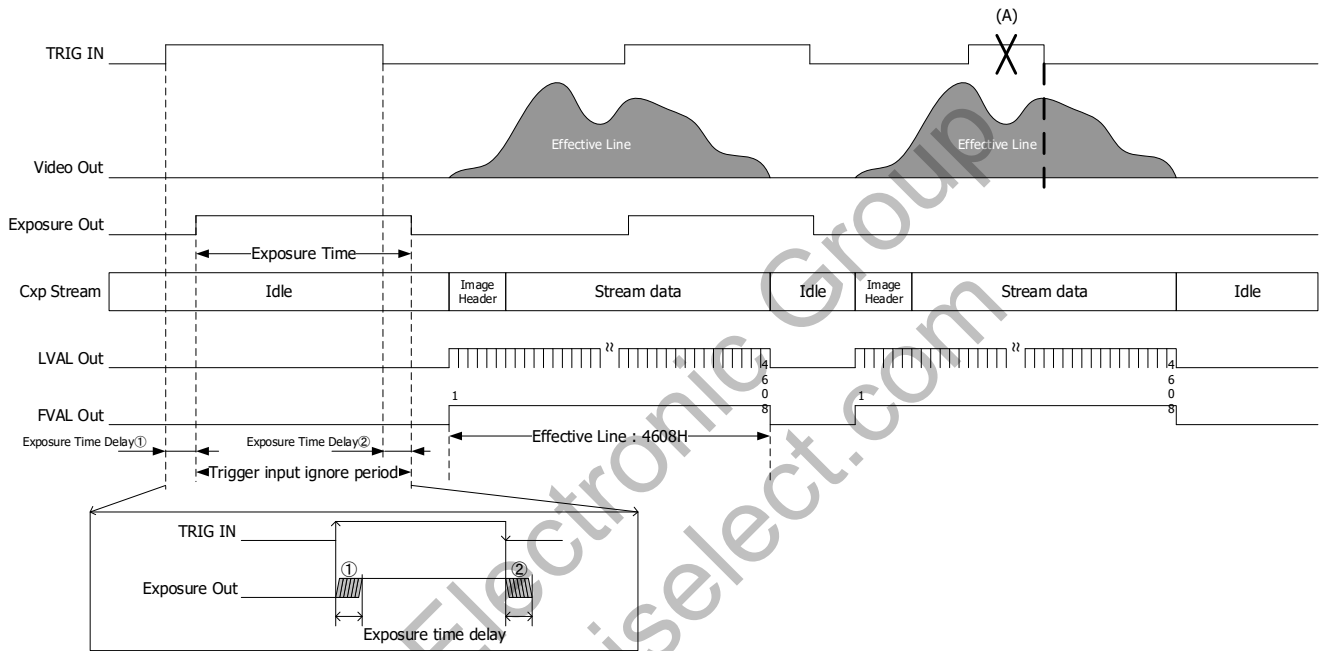

#### 4.14. FAST Pulse Width Trigger Shutter Mode (ClockSync) CLK Sync Trigger

(TriggerMode=On, TriggerSyncMode=ClockSync, TriggerActivation=LevelHigh)

- This is a mode to start exposure with external trigger input and set exposure time with pulse width of trigger signals.
- Trigger operation is CLK sync V sync reset.

The delay time (Exposure Time Delay①) from detecting trigger edge in the camera to starting exposure is approx. **0.1μs**.

The delay time (Exposure Time Delay②) from detecting trigger edge in the camera to end Exposure Out

Video output format	Exposure Time Delay②
Mono8	4H + 0.1us + 2.46us
Mono10	4H + 0.1us + 2.46us
Mono12	2H + 0.1us + 2.46us

- Pulse width **1 μs** (Min.) ~ Approx. 2 frames

Functionally, there is no upper limitation, but noises such as dark noise shadings may be noticeable at long time exposure.

- Exposure Out shows the exposure period.

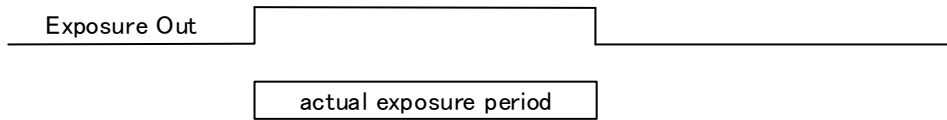

- Trigger input while readout period will be ignored in the camera. ((A) in the drawing below)

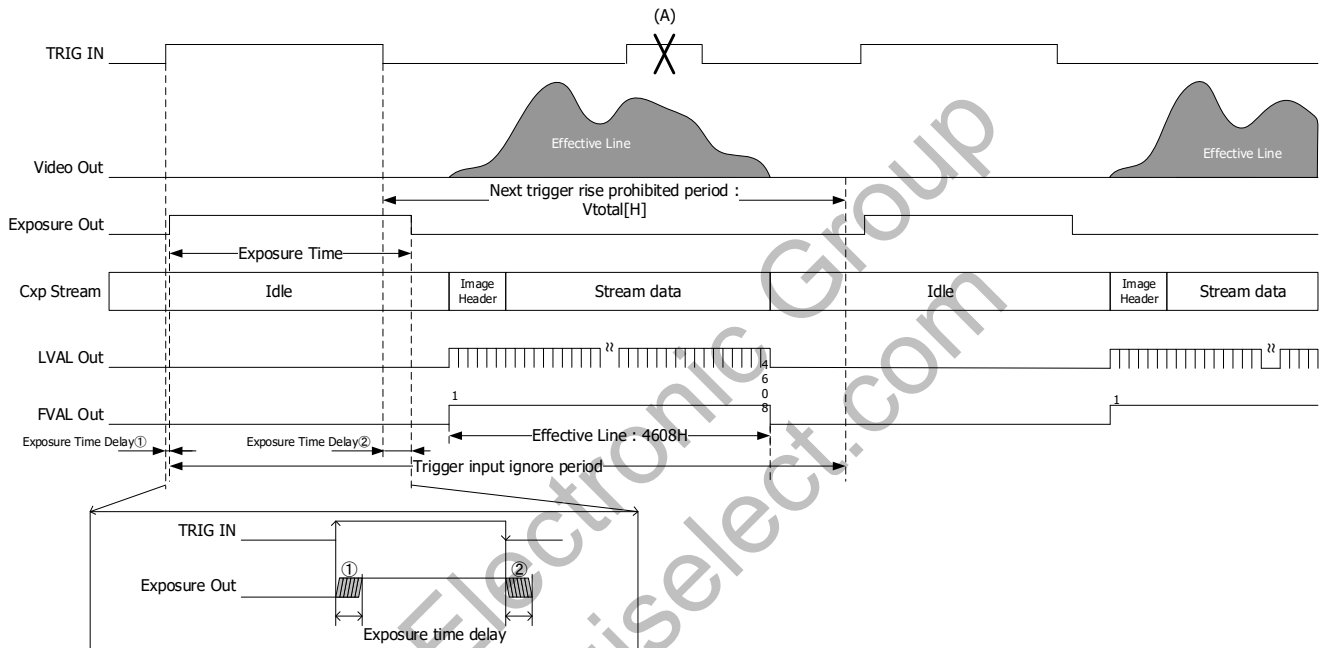

4.15. Exposure Time

AcquisitionControl	
ExposureMode	Timed TriggerWidth
ExposureTime (us)	12us ~ Max. exposure time: LineSync 98us ~ 200ms: ClockSync
ExposureTimeMax	(ReadOnly)

ExposureMode: This is to check if current mode is Timed or TriggerWidth (PWC).

ExposureTime: Exposure time (Valid when ExposureMode is Timed.)

- Set per 1H when the trigger operation is H sync. It will return the value (us) rounded by 1H per Min. 1H mode.
- Set per approx. 1us when the trigger operation is CLK sync.

ExposureTimeMax: Max. exposure time

- Set the smaller value than ExposureTimeMax when the camera is internal sync mode. It will depend on partial scan (ROI) settings, ConnectionConfig, and PixelFormat.
- The maximum of H sync trigger mode (LineSync) will be clipped with effective line count (Including when the camera is set to ROI).
- CLK sync trigger mode (ClockSync) can be set in the range of 98us~200ms. It will not be clipped with effective line count.

#### 4.16. Formula to Calculate Manual Shutter Values with H Sync Mode

The value will be corrected to the value corresponds to the following formula.

- Formula: Exposure time = Time for 1 line (Please refer to the time for 1H in the table of [Section 3.5.1](#)) × Exposure line count + **2.46μs**

※ The Min. setting value will be clipped with 1, and the Max. value will be clipped with 4608 or with the total line count of partial mode.

#### 4.17. Manual Shutter Settings with CLK Sync Mode (FAST Trigger Mode)

- Min. setting value: **98μs (Approximate value)**
- Max. setting value: **200ms (Approximate value)**
  - ※ Unlike H sync mode, exposure time will not be clipped with total line count, etc.
  - ※ Bright point may be noticeable with long time exposure.
- Setting unit: 1μs (Approximate value) ※ Slight differences may occur since it is generated by 74.25MHz.
- Formula: Exposure time = Setting value – Delay time (Please refer to Delay time in [Section 4.13](#))

#### 4.18. Gain

AnalogControl	
Gain	1.00 ~ 256.00

- ♦ Gain: User can set gain value in the range of x1.00~x256.00 per 0.01 step.  
Functionally gain can be set up to x256.00 however, the guarantee range is up to x64.00.  
With high gain settings, noise will increase and image quality deteriorates.

#### 4.19. Gamma Correction

AnalogControl	
Gamma	0.10 ~ 1.80

- ♦ Gamma: This is to set gamma correction value in the range of 0.10 ~ 1.80 per 0.01 step.

[Note]

Camera updates gamma table at the timing of image output. With continuous operation mode, camera applies the updated gamma table at the timing of image output after completion of rewriting gamma table. (Approx. 20ms: Please refer to Command ACK as a rough guide)

If user changes gamma coefficient while waiting for a trigger input, camera outputs images with updated gamma table with a trigger after completion of rewriting gamma table.

## 4.20. Black Level Adjustment

- This is to adjust black level of image sensor.

AnalogControl	
BlackOffset	-64 ~ 63

[Note]

This is not a function to set absolute value of black level.

Black level of image sensor can be changed proportionally.

This is a value converted by 12bit. The value will be equivalent to  $\pm 16$  with 10bit, and equivalent to  $\pm 4$  with 8bit.

Please set x4 of signal level with 10bit image and x16 of signal level with 8bit image.

User can change setting values while capturing images. However, disturbance images may occur.

## 4.21. Partial Scan (ROI)

- This is to increase frame rate by cutting and reducing read out area.

ImageFormatControl	
RegionSelector	EffectiveRegion, Region0
RegionMode	On (Fixed)
RegionDestination	Stream0 (Fixed)
Width	640 ~ 5328 (Multiples of 16)
Height	480 ~ 4608 (Multiples of 8)
OffsetX	0 ~ 4688 (Multiples of 16)
OffsetY	0 ~ 4128 (Multiples of 8)

- ♦ RegionSelector : This is to select Region to set.  
User can set partial area with Region0.  
Select EffectiveRegion to output image.
- ♦ RegionMode : This is to set valid/invalid of Region0. This model is fixed to On.
- ♦ RegionDestination : This is to select Stream to output. This model is fixed to Stream0.
- ♦ Width : This is to set the width of Region.
- ♦ Height : This is to set the height of Region.
- ♦ OffsetX : This is to set offset for X direction of Region.
- ♦ OffsetY : This is to set offset for Y direction of Region.

※ Please set Width, Height, OffsetX, and OffsetY to meet the conditions below.

$$640 \leq \text{OffsetX} + \text{Width} \leq 5328$$

$$480 \leq \text{OffsetY} + \text{Height} \leq 4608$$

- Total line count per frame = V blanking line count + partial effective line count  
However, make sure that partial effective line (except V blanking line) is less than 4608.

V blanking line count with partial mode:

©2024 CIS Corporation. All rights reserved.

Video output format	V blanking line count
Mono8	108
Mono10	106
Mono12	100

- Frame rate = 1 / (Total line count per frame × Time for 1 line)

Time for 1 line: Please refer to the time for 1H in the table of [Section 3.5.1](#).

- Partial scan can be set from 640 of width direction with multiple numbers of 16, and from 480 of height direction with multiple numbers of 8.
- With partial scan, the effective line count of manual shutter setting becomes the maximum value (except at ClkSync trigger).
- When switch between Full frame scan mode and Partial scan mode, or changing partial settings, 1 frame after the change will be invalid.

Especially with fixed trigger shutter mode and pulse width trigger shutter mode, input a dummy trigger first, then use subsequent triggers as actual video signals.

#### 4.22. Image Quality Selecting Mode

- This is to select image quality of output image.

AnalogControl	
ImageQualityMode	StandardMode LowFrameRateMode

- ♦ Image Quality Mode : Image quality selecting mode
- ♦ StandardMode : Standard mode
- ♦ LowFrameRateMode : SSN will be improved compared to StandardMode, however the sensitivity will be decreased. Frame rate will be the same as the one with 10bit.  
User can set only when PixelFormat is set to Mono8.  
When select Mono10/12, Image Quality Mode will be updated to StandardMode.

#### 4.23. Shading Correction

- This is to correct the drop in the amount of peripheral light caused by lens and others.

AnalogControl	
ShadingCorrectionDataSelector	Off/Table1/Table2/Table3
DetectShading	(Execute)

- ♦ ShadingCorrectionDataSelector:  
Select shading correction ON/OFF, shading correction table to use, and where to save the detected shading correction data.  
Shading correction become invalid when selecting Off.  
When selecting Table1 - Table3, correction function will be ON according to each correction value.  
User can acquire correction data to the specified table by executing DetectShading while selecting Table1- Table3.

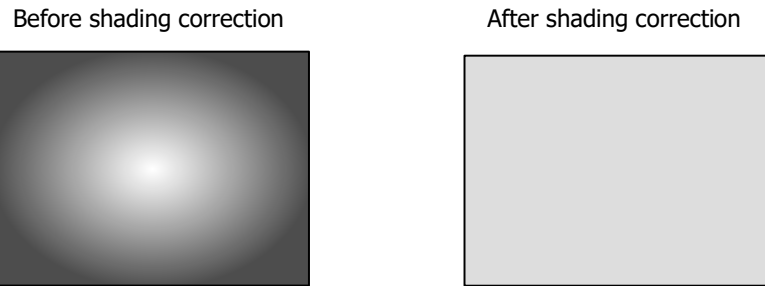

**DetectShading** : Shoot an object with stable brightness such as pattern box to full screen, and execute shading detection to calculate shading correction data automatically. Calculated correction data will be saved to the table selected with **ShadingCorrectionDataSelector**.

[Note]

- Make sure to turn OFF partial mode when detect shading.  
(Please set to the size of 5328x4608 to execute.)
- Acquire correction data only when camera is in operation. Acquisition of shading correction data is invalid when there is no output from camera.
- When executing **UserSetSave**, Correction data of Table1~Table3 will be saved in the camera non-volatile memory at the same time.
- Camera will maintain correction data even executed Default with **UserSetLoad**.
- User cannot execute when **ShadingCorrectionDataSelector** is Off.

#### 4.24. Impulse Noise Removal Filter

- This is to detect impulse noise dynamically by image processing to delete it.

<b>AnalogControl</b>	
<b>ImpulseNoiseFilter</b>	On/Off
<b>ImpulseNoiseFilterThreshold</b>	0~4095

- ♦ **ImpulseNoiseFilter**: Control On/Off of noise removal.  
We recommend to turn **ImpulseNoiseFilter** On if the entire noise cannot be removed by [Section 4.25 Defective Pixel Correction](#).
- ♦ **ImpulseNoiseFilterThreshold**:  
This is to specify the intensity of noise detection/removal function.  
The smaller the value is, the bigger effect can be obtained. However, negative effect will occur if the value is too small. Therefore, please set the value around 256. It will equivalent to Off when set the value to 4095.
- Even **ImpulseNoiseFilter** is On, this function will be invalid when **DefectPixelCorrenction** is Off.

4.25. Defective Pixel Correction

- This is a function to detect, add, and correct defective pixels in output data from the sensor.
- There are two types of defective pixel data.
  - Defective data registered at factory
    - Black and white defective pixel data registered upon shipment from our factory.
    - These data cannot be over-written.
  - Defective data registered by user
    - In addition to the correction of defective pixel data registered upon shipment, we provide a method to update the defective pixel data. With DefectPixelDefault command, user can delete these user-registered data.
    - UserSetDefault does not initialize this data.
- User can register up to 256 points. (Note: UP to 64 points per CH.)

[CH (Channel)]

Camera performs image processing with 4CH interleave.

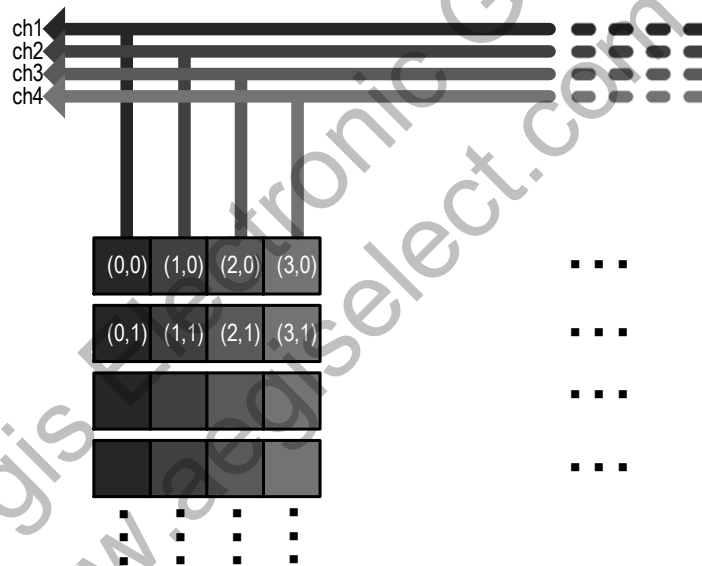

Defective pixel correction function calculates value for X pixel referring to peripheral pixels (up and down, left and right). When all peripheral pixels, X1, X2, X3, and X4, are already registered as defective pixels, X pixel cannot be corrected even when user registered new X pixel.

How to control defective pixel correction

This is to turn ON/OFF defective pixel correction processing.

Defective pixel correction data at factory and defective pixel correction data registered by user will be both controlled at the same time.

<b>AnalogControl</b>	
DefectPixelCorrection	ON/OFF
DefectPixelAdd	(Execute)
DefectPixelAddOffsetX	0 ~ 5327
DefectPixelAddOffsetY	0 ~ 4607
DefectPixelDelete	(Execute)

Defective data registered by user

This is to add the designated X and Y coordinate.

Any preferred pixels can be registered and deleted as defective pixels by designating coordinates.

- DefectPixelCorrection: This is to select valid/invalid of defective pixel correction.
  - DefectPixelAddOffsetX: Designate X coordinate
  - DefectPixelAddOffsetY: Designate Y coordinate
  - Please execute DefectPixelAdd to register the designated coordinate as a defective pixel correction point.
  - Please execute DefectPixelDelete to delete the designated coordinate registered as defective pixel correction point.
- ※ If the coordinate same as defective data at factory is designated, it will be ignored.
- ※ Only the defects added by "DefectPixelAdd" or "DefectDetection" can be deleted.  
Factory setting data cannot be deleted by this command.

Defective pixel detection registered by user

This is to detect and register correction data of white defect caused by image sensor.

<b>AnalogControl</b>	
DefectDetectionThresholdValue	0 ~ 4095
DefectDetection	(Execute)
DefectDetectionStatus	(ReadOnly)
DefectPixelDefault	(Execute)
DefectCorrectMode	Reacquire/Add

♦ DefectDetectionThresholdValue:

This is to set a threshold value (0~4095: 12bit conversion) for user defective pixel detection. Data which exceeds the luminance level designated here will be registered.

Designate a value of 4 times of signal level with 10bit images, and designate a value of 16 times of signal level with 8bit images as a threshold value.

- ◆ DefectDetection

This is to detect defective pixels registered by user.

Function automatically registers pixels that exceed the level designated with DefectDetectionThresholdValue.

Execute DefectDetection by shielding lights to the image sensor.

Function reflects DefectDetection immediately after executed.

Execute UserSetSave after DefectDetection to save data into non-volatile memory.

- ◆ DefectDetectionStatus: This is to indicate results of defective pixel detection proceeded by user.

0	No defective pixel correction data registered by user.
Value (256 or less)	The number of detected defective pixels registered by user.
0x000e0001 (917505)	Total number of defective pixel correction data exceeds the maximum number to register in one CH. (64 points)
0x000e0002 (917506)	Total number of defective pixel correction data exceeds the maximum number to register (256 points) ※ Error indication may be decimal depending on the grabber board to use.

When the value 257 or more is indicated, check if user threshold value (DefectDetectionThresholdValue) and the indication of defective pixels (DefectivePixelCorrection) are appropriate.

- ◆ DefectPixelDefault: This is to delete entire defective pixel correction data registered by user.

- ◆ DefectCorrectMode: This is to set detection mode of defective pixels.

Reacquire mode: This mode deletes defective pixel data except those added by one point addition and reacquire defective pixels.

Add mode: This mode acquires defective pixels in addition to the current pixels registered.

[Note]

- ◆ Make sure to acquire defective pixel correction data when camera is in operation.

(White defects cannot be detected when camera is not output anything.)

- ◆ Make sure to turn OFF custom ROI mode to detect defective pixels registered by user.

(Size must be 5328x4608 to execute.)

- ◆ The number of defective pixels increases as the temperature rises.

If defective pixels remain even change the threshold value with DefectDetectionThresholdValue and reacquire defective pixels, we recommend you to use [Section 4.24 Impulse Noise Removal Filter](#) concurrently.

- ◆ To acquire user defective pixel correction data by changing threshold value of DefectDetectionThresholdValue, execute DefectPixelDefault first to delete defective pixel correction data registered by user and reacquire it.

- ◆ In case of DefectDetectionStatus becomes 0x000e0001 and 0x000e0002, it means there is a problem with the detection result. Therefore, please execute DefectPixelDefault to delete defective pixel correction data registered by user, and reacquire them by changing threshold value.

- ♦ Maximum number of defective pixels to register and to correct may not always be the same due to following reasons.
  - (1) With white defects detection, if one of interleave channel reaches the maximum number of defective pixels to register, correction stops. Function registers data up to that point, outputs error, and ends its operation.
  - (2) When there is no effective pixel around the pixel to add (on the left, right, top, and bottom), user can register but cannot correct that pixel.

□ Indication of defective pixels

This is to indicate the coordinates of defective pixels registered by user.

<b>AnalogControl</b>	
RegisteredDefectSelector	UserState/InitialState
DefectPixelNumber	1~256/1~768
DefectPixelOffsetX	(ReadOnly)
DefectPixelOffsetY	(ReadOnly)
DefectPixelType	(ReadOnly)

- ♦ RegisteredDefectSelector : This is to select the types of registered defects.
  - ♦ UserState: Defective correction data registered by user
  - ♦ InitialState: Defective correction data registered at factory
- ♦ DefectPixelNumber : This is to set the number of the registered defective pixels.
 

This is to designate a table number of the defective data registered at factory and by user.
- ♦ DefectPixelOffsetX : This is to indicate X coordinate of the defective pixel designated with DefectPixelNumber. When user designated a table number with no defective pixel data, it shows 65535.
- ♦ DefectPixelOffsetY : This is to indicate Y coordinate of the defective pixel designated with DefectPixelNumber. When user designated a table number with no defective pixel data, it shows 65535.
- ♦ DefectPixelType : This is to indicate the types of defects designated with DefectPixelNumber.
  - 1: White defects registered upon shipment from factory
  - 2: Black defects registered upon shipment from factory
  - 6: Defects registered by user
  - 7: Defects additionally registered by user
  - 65535: Table without defects

<b>AnalogControl</b>	
ChannelNumber	1~4
DefectPixelChannelCount	(ReadOnly)

- ♦ ChannelNumber: This is to designate channel number of defective pixel processing.
- ♦ DefectPixelChannelCount: Indicate the number of defective pixels for the channel number designated with ChannelNumber. The number of defective pixel of the designated channel number is the sum total of defective pixel number upon shipment and the number of defective pixels registered by user.

## 4.26. Test Pattern Indication

- This is to output test pattern from camera. This is useful to check if your system is operating properly.

ImageFormatControl	
TestPattern	Off GrayHorizontalRamp GrayHorizontalRampMoving

※ Test pattern indication cannot be used when cursor is indicated.

## 4.27. Cursor Indication

- This is to indicate cursor on your display screen.

ImageFormatControl	
CursorPattern	Off/On
CursorOffsetX	X coordinate
CursorOffsetY	Y coordinate
CursorColor	White/Black

※ Cursor indication cannot be used when test pattern is indicated.

- CursorPattern : Cursor indication On/Off.
- CursorOffsetX : X coordinate of vertical cursor.
- CursorOffsetY : Y coordinate of horizontal cursor.
- CursorColor : This is to select the color of cursor. (black or white)

## [Note]

- With partial (ROI) indication, the origin (0, 0) of cursor coordinate will be the top left in active area.
- When decrease in size of the image, cursor may not be shown.

## 4.28. LED Operational Mode

- This is to change operational mode of LED at the rear of camera. For information on lighting patterns, refer to

[Section 3.3.3. LED Indicator.](#)

DeviceControl	
DeviceIndicatorMode	Active ErrorStatus Inactive

- Active : Indication of communication status of CoaXPress.
- ErrorStatus : OFF with normal operation. Lights only with system error.
- Inactive : ALL LED OFF.

## 4.29. Camera Timing Output

- According to LineSource settings, camera outputs the following signals through pin No. 3 of 6pins circular connector.

DigitalIOControl	
LineSelector	Line0
LineMode	Output
LineSource	OFF ExposureActive FrameActive LineActive TriggerPacketActive

- LineSource : This is to select output signals.
  - ExposureActive : This is to indicate exposure period of image sensor with Hi Active.
  - FrameActive : This is to indicate effective period of frame with Hi Active. (FVAL)
  - LineActive : This is to indicate effective period of video output line with Hi active. (LVAL)
  - TriggerPacketActive : This is to decode and output packet signals of uplink trigger from frame grabber. (LinkTrigger)

## 4.30. User ID

DeviceControl	
DeviceUserID	Manual
DeviceUserString	Manual

Set a letter string as DeviceUserID with up to 16 characters and as DeviceUserString with up to 256 characters including NUL letter ( ). Execute UserSetSave to save these letter strings to camera non-volatile memory. These data will be kept even executing "UserSetLoad" with "Default."

## 4.31. Temperature Indication

- This is to indicate temperature of image sensor ( C)

DeviceControl	
DeviceTemperatureSelector	Sensor (Fixed)
DeviceTemperature	(ReadOnly)

- DeviceTemperatureSelector : This is to select where to measure the temperature of the device.  
This model is fixed to sensor temperature.
- DeviceTemperature : Indicate the temperature of image sensor.

[Note]

- The value of register is not calibrated. Please regard it as reference value.

## 5. Factory Settings

Function	Data	Descriptions
TriggerSelector	AcquisitionStart	Equivalent to TriggerMode=Off
TriggerMode	Off	Operate with TriggerSelector at the same time.
TriggerSyncMode	LineSync	Horizontal sync mode
TriggerSource	LinkTrigger0	CXP UPLink trigger
TriggerActivation	RisingEdge	Rising edge
ExposureTime	10008.0	Exposure time (10008us)
ExposureTimeMax	87319.0	Exposure time Max. value (87319us)
Gain	1.00	x1.00
Gamma	1.00	Gamma coefficient=1.00
DefectPixelCorrection	On	Defective pixel correction On
DefectPixelAddOffsetX	0	X coordinate of defective pixel
DefectPixelAddOffsetY	0	Y coordinate of defective pixel
DefectDetectionThesholdValue	200	Threshold value of defective pixel detection
ShadingCorrectionDataSelector	Off	Shading correction Off
ImageQualityMode	StandardMode	Image quality selection mode (Normal mode)
ImpulseNoiseFilter	Off	Impulse noise removal filter On/Off
ImpulseNoiseFilterThreshold	256	Impulse noise removal filter threshold value
BlackOffset	0	Black level initial value
PixelFormat	Mono8	MONO model
ConnectionConfig	CXP3_X1	CxpLinkConfiguration
TestMode	NomalOperation	Use when Link test is Off
RegionSelector	EffectiveRegion	Specify the number for partial area (ROI) (Region0)
RegionMode	On	Partial area (ROI) operation On (Fixed)
Width	5328	Specify width of partial area (ROI)
Height	4608	Specify height of Partial area (ROI)
OffsetX	0	Specify X start position of partial area (ROI)
OffsetY	0	Specify Y start position of partial area (ROI)
ReverseX	False	Horizontal flip OFF
TestPattern	Off	Cannot use cursor indication at the same time.
CursorPattern	Off	Cannot use test pattern at the same time.
CursorOffsetX	2664	Position of cursor X
CursorOffsetY	2304	Position of cursor Y
CursorColor	White	Cursor color White/Black
DeviceIndicatorMode	Active	Display LED indicator
LineSource	Off	Circular 6P-3pin output setting
DeviceUserID		User set letter string (16 letters)
DeviceUserString		User set letter string (256 letters)

※ ConnectionConfig, PixelFormat, and ImageQualityMode are not subject to the operation of UserSetLoad.

Aegis Electronic Group  
www.aegiselect.com

6. Dimensions

6.1. Camera Dimensions

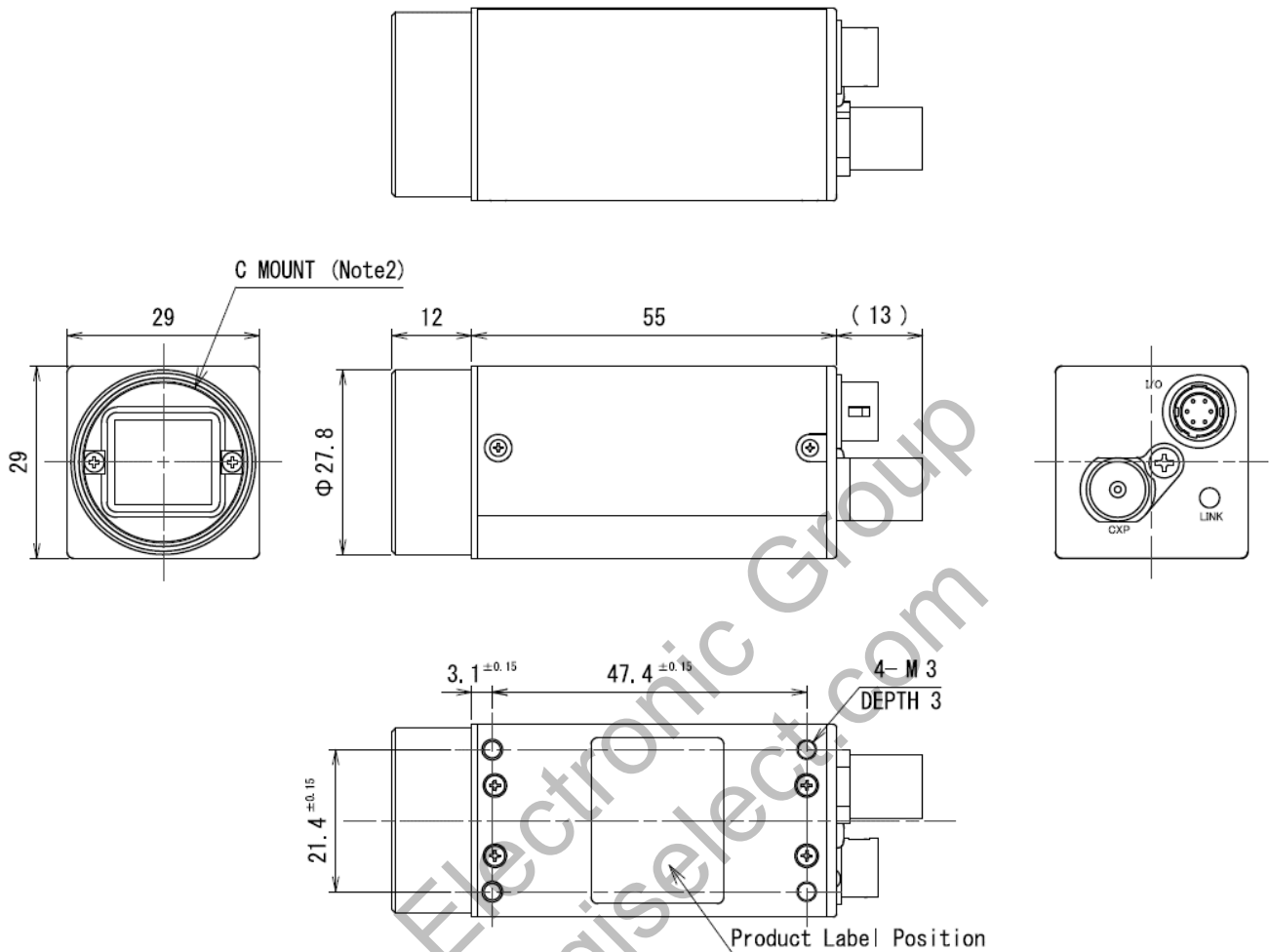

Note2) C mount screws comply with ANSI/ASME B1.1.1-32UN(2B).

Note1) Screw length from the lens mount surface shall be less than 6mm.  
 And protruding portion of the C mount lens shall be less than 10mm.

(UNIT:mm)

6.2. Optical Axis Accuracy

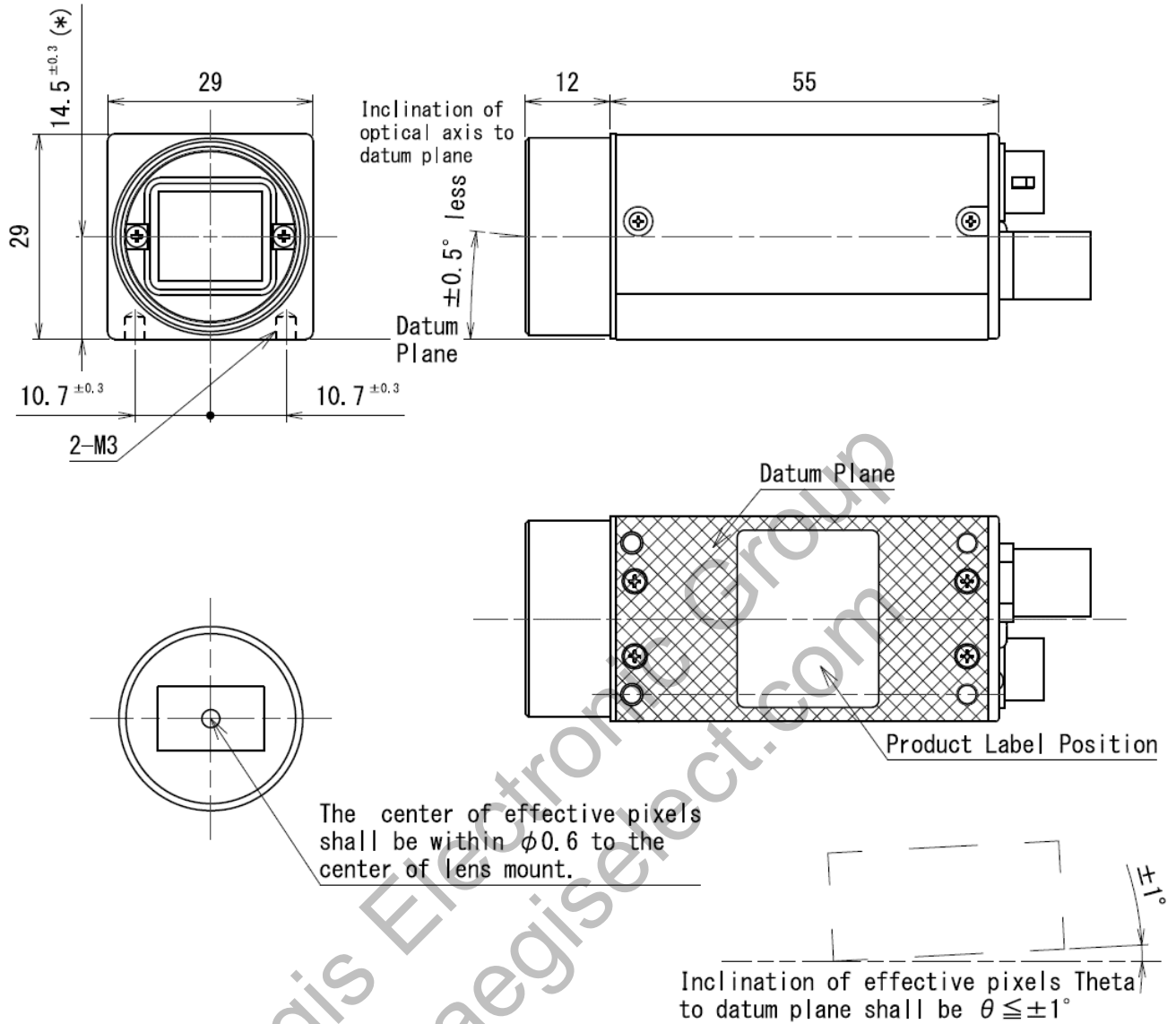

(\*Dimension from datum plane to the center of lens mount.

(Unit:mm)

## 7. Case for Indemnity (Limited Warranty)

### 7.1. Product Warranty

The term of warranty of this product is within 3 years from the date of shipping out from our factory.

If you use the product properly and discover a defect during the warranty period, and if that was caused by designing or manufacturing, CIS Corporation, at its option, repairs or replaces it at no charge to you. Products out of warranty period will be subject to charge.

CIS should not hold responsible for damages or losses if;

- damages or losses are caused by earthquake, lightning strike, fire, flood or other acts of God.
- damages or losses are caused by deliberate or accidental misuse by user, or failure to observe the information contained in the instructions in this Product Specification and Operational Manual.
- damages or losses are caused by repair or modification conducted by customer or any unauthorized party.

### 7.2. CMOS Defective Pixels

CIS applies defective pixel correction prior to the shipment of the product. However, the number of defective pixels are subject to increase due primarily to the effect of cosmic rays. Due to this nature, CIS should not hold responsible for the natural increase of defective pixels.

### 7.3. Product Support

Should you have any problems in function of the product you purchased, and if you need our further analysis and/or repair, please contact your local distributor.

Aegis Electronic Group  
www.aegiselect.com