

CIS

CoaXPress I/F
20.35M pixels CMOS CMOS (RAW) Camera

VCC-20CXP6R

Product Specifications & Operational Manual

(Preliminary)

CIS Corporation

Table of Contents

1.	Handling Precautions	1
1.1.	Camera Handling Precautions	1
1.2.	Restrictions on Applications	1
1.3.	Disclaimers (Exception Clause)	1
1.4.	Known Issue	1
1.4.1	Application Manufactured by Euresys s.a	1
2.	Product Outline	2
2.1.	Features	2
3.	Specifications	3
3.1.	General Specifications	3
3.2.	Input and Output Specifications	4
3.2.1	Trigger Input (12pins circular connector, No.11 pin)	4
3.2.2	Trigger Output (12pins circular connector, No.6 and 7 pin)	4
3.3.	External Connector Pin Assignment	5
3.3.1	12pins Circular Connector	5
3.3.2	75Ω HD-BNC Connector	5
3.3.3	LED Indicator	6
3.4.	Spectral Response	6
4.	Output Timing	7
4.1.	Horizontal Sync Timing	7
4.2.	Vertical Sync Timing	8
5.	Camera Functions	9
5.1.	Camera Interface	9
5.2.	How to Save and Initialize Settings	9
5.3.	Link Speed and Link Count	10
5.4.	Pixel Format	10
5.5.	Trigger Mode	11
5.5.1	Internal Sync Mode (Free Run Mode)	11
5.5.2	External Trigger Sync Mode	11
5.6.	Trigger Sync Mode and Delay Time to Start Exposure	13
5.7.	Restrictions on Trigger Pulse Input Timing	13
5.8.	Fixed Trigger Shutter Mode (LineSync) H Sync Trigger	14
5.9.	FAST Fixed Trigger Shutter Mode (ClockSync) CLK Sync Trigger	15
5.10.	Pulse Width Trigger Shutter Mode (LineSync) H Sync Trigger	16
5.11.	FAST Pulse Width Trigger Shutter Mode (ClockSync) CLK Sync Trigger	17
5.12.	Exposure Time	18
5.13.	Formula to Calculate Manual Shutter Values with H Sync Mode	19
5.14.	Manual Shutter Settings with CLK Sync Mode (FAST Trigger Mode)	19
5.15.	Gain	19
5.16.	Gamma Correction	19
5.17.	Partial Scan (ROI)	20
5.18.	White Balance	22
5.19.	Black Level Adjustment	22
5.20.	Image Quality Selecting Mode	23
5.21.	Shading Correction	23
5.22.	Flip	24
5.23.	Defective Pixel Correction	24

5.24.	Test Pattern Indication.....	28
5.25.	Cursor Indication	28
5.26.	LED Operational Mode.....	28
5.27.	Camera Timing Output	29
5.28.	User ID	29
5.29.	Temperature Indication.....	29
6.	Factory Settings	30
7.	Dimensions.....	31
7.1.	Camera Dimensions.....	31
7.2.	Optical Axis Accuracy.....	32
8.	Case for Indemnity (Limited Warranty).....	33
8.1.	Product Warranty	33
8.2.	CMOS Defective Pixels	33
8.3.	Product Support.....	33

PRELIMINARY
Aegis Electronic Group
www.aegiselect.com

1. Handling Precautions

1.1. Camera Handling Precautions

- Do not use or store camera in dusty or humid places.
- Do not apply excessive force, vibration, or static electricity that could damage camera. Please handle camera with care.
- Do not shoot direct images that are extremely bright (e.g., strong light source, sun, etc.). When extremely strong light source is shot, smear or blooming may occur. Put the lens cap on when camera is not in use.
- Follow the instructions in [Chapter 3.3., "External Connector Pin Assignment"](#) for connecting camera. Improper connection may cause damages not only to the camera but also to the connected devices.
- Confirm mutual ground potential carefully before connecting camera to monitors or computers. Any AC leak from the connected devices may cause damages or destroy the camera.
- Do not apply excessive voltage. (Use only the specified voltage.) Unstable or improper power supply voltage may cause damages or malfunction of the camera.
- Our warranty does not apply to damages or defects caused by irregular and/or abnormal use of the product.

Our warranty does not apply to damages or defects caused by neglecting the instructions and precautions explained in this manual.

1.2. Restrictions on Applications

- The camera must not be used for any nuclear equipment or aerospace equipment with which mechanical failure or malfunction could result in serious bodily injury or loss of human life.
- The camera must not be used under conditions or environments other than those specified in this manual.

1.3. Disclaimers (Exception Clause)

CIS should not be liable for any damages or losses if:

- damages or losses are caused by earthquake, lightning strike, fire, flood, or other acts of God.
- damages or losses are caused by deliberate or accidental misuse by user, or failure to observe information and instructions explained in this manual.
- damages or losses are caused by repair or modification conducted by user or any unauthorized party.

1.4. Known Issue

1.4.1 Application Manufactured by Euresys s.a.

- If you start acquiring images with all partial area (ROI) OFF, the application will perform a force-quit. Please make sure to set more than one ROI.
- The application and version for which this issue has been confirmed are as follows.
 - Application: Euresys GenICam Browser
 - Version: 12.8.1.54
- ※ This issue might not occur other than this version, however make sure to set more than one ROI.

2. Product Outline

VCC-20CXP6R is color camera with CoaXPress interface. Using 1.1", global shutter type 20.35M pixels CMOS image sensor. Complies with CoaXPress Version 1.1.1. Must have function ready for Machine Vision applications such as trigger shutter, ROI, Gain, black level adjustment, defective pixel correction, and PoCXP. Suitable for various FA/Machine vision applications.

2.1. Features

- Dimensions: 65mm(H) x 65mm(W) x 93.3mm(D)
- Global shutter type, CMOS sensor
- Complies with CoaXPress CXP-3, CXP-6, and CXP-12
- Exposure setting, Gain setting
- External trigger mode (Fixed trigger shutter mode / Pulse width trigger shutter mode)
- Complies to GenICam
- M48 lens mount

3. Specifications

3.1. General Specifications

Electrical Specifications			
Image sensor	Sensor type	1.1", Global shutter type CMOS sensor	
	Effective pixels	4512(H) × 4512(V)	
	Unit cell size	2.74μm(H) × 2.74μm(V)	
Interface		Complies with CoaXPress 1.1.1. Supports CXP-12, CXP-6, and CXP-3	
Video output format		Mono8 / Mono10 / Mono12 / BayerRG8 / BayerRG10 / BayerRG12	
Frame rate	CXP-12 x2 8bit/10bit/12bit	79.6fps(*) / 65.6fps / 56.6fps (TBD)	
	CXP-12 x1/ CXP-6 x2 8bit/10bit/12bit	54.8fps(*) / 43.2fps / 36.3fps (TBD)	
	CXP-6 x1/ CXP-3 x2 8bit/10bit/12bit	27.4fps(*) / 21.6fps / 18.2fps (TBD)	
	(*) Frame rate will become the same as 10bit with LowFrameRateMode.		
Sync system		Internal sync.	
Resolution (The maximum pixel size)		4512(H) × 4512(V) / with 8bit 4480(H) × 4512(V) / with 10bit/12bit	
Video signals (Gain 0dB)	White clip level	255	with 8bit
	Set up level	0~2	with 8bit
	Dark shading	4 or less for both horizontal and vertical	with 8bit
Sensitivity		F11 (TBD) 2000lx (Shutter speed 1/30s, Gain 0dB, Mono8) F5.6 (TBD) 2000lx (Shutter speed 1/30s, Gain 0dB, Mono10, 12)	
Minimum illumination		F1.4 3.0lx (TBD) (Shutter speed 1/30s, Gain+18dB, Mono8, level=50%) F1.4 10lx (TBD) (Shutter speed 1/30s, Gain+18dB, Mono10, 12, level=50%)	
Gain variable range		x1~x64 (0dB~+36dB) [Guarantee range]	
Shutter speed		Manual setting	
Trigger mode		Free run mode (Camera internal trigger) Trigger mode (Host, External terminal) <ul style="list-style-type: none"> ▪ Fixed trigger shutter ▪ Pulse width trigger shutter 	
Partial scan		Vertical 8 areas can be set.	
Power requirements		PoCXP: 18.5~26V EXT-Vin: 18.5~26V (Power supply cable of circular connector must be 10m or less.)	
Power consumption		12.5W(TBD) (CXP-12 x2Lane), [with free run]	
Mechanical Specifications			
Dimensions		H:65mm W:65mm D:93.3mm excluding projection.	
Weight		390g	
Lens mount		M48 mount	

Environmental Specifications			
Safety/Quality Standards			
UL: Complies with UL Standard including materials. CE: EMC: 2014/30/EU Emission: EN61000-6-4:2007+A1:2011 Immunity: EN61000-6-2:2019 RoHS: 2011/65/EU, 2015/863/EU EN50581 (RoHS2)			
Durability	Vibration	Acceleration	: 98m/s ² (10G)
		Frequency	: 20~200Hz
		Direction	: X, Y, and Z 3 directions
		Testing time	: 120min each
	Shock	No malfunction with 980m/s ² (100) G for ±X, ±Y, and ±Z, 6 directions without packaging.	
Operational temperature		0 ~ +45°C Humidity: 20 ~ 80%RH with no condensation.	
Storage temperature		-25 ~ +60°C Humidity: 20 ~ 80%RH with no condensation.	

3.2. Input and Output Specifications

3.2.1 Trigger Input (12pins circular connector, No.11 pin)

- 5.0, 3.3V CMOS level/TTL level
- Input voltage Low: 0.5Vdc (Max), High: 2.1Vdc (Min)

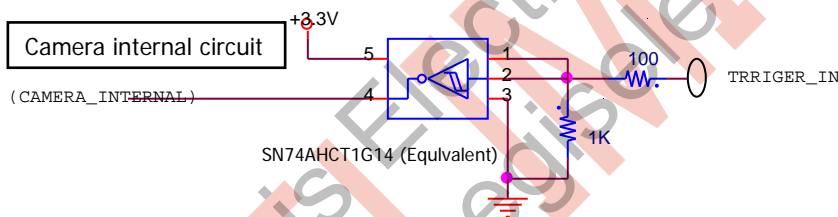

3.2.2 Trigger Output (12pins circular connector, No.6 and 7 pin)

- 5.0V CMOS logic level output
- Output voltage Low: 0.35Vdc (Max), High: 4.5Vdc (Min)

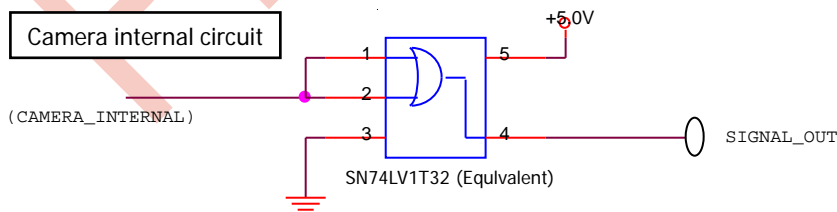

3.3. External Connector Pin Assignment

3.3.1 12pins Circular Connector

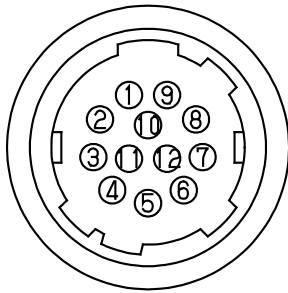

HR10-10R-12PA (73)
(HIROSE) or equivalent

Pin No.	Signals	Description
1	GND	Electrically connected with camera chassis.
2	POWER	DC power input
3	NC	
4	NC	
5	GND	Electrically connected with camera chassis.
6	GPO1	General output (Low with initial setting)
7	GPO2	General output (Low with initial setting)
8	NC	
9	NC	
10	NC	
11	GPI	Trigger input
12	GND	Electrically connected with camera chassis.

※ NC=Non-Connection. Do not connect anything to the terminal.

※ Recommendation on power source voltage.

1. Power source voltage: E[V]
2. Length of cable to use: l[m]
3. Resistance value per 1m of cable: r[Ω/m]

Following is the formula to calculate output voltage of external power supply:

$$E[V]=24[V]+r[\Omega/m]\times l[m]\times 0.6[A]$$

Please make sure to supply appropriate E[V]. Voltage from external power supply must meet specifications specified in [Section 3.1. General Specifications](#) to input to camera connector.

Make sure to stop power supply from PoCXP cable when you supply power from 12pins circular connector.

When supply power from circular connector, the cable length must be 10m or less.

3.3.2 75Ω HD-BNC Connector

- CoaXPress video output signals.
- No.1 pin is a connector for PoCXP.

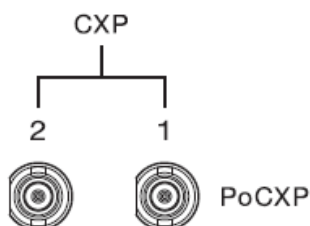

- ※ With power supply via PoCXP, please make sure the amount of electric current is available with frame grabber board.
- ※ Outer diameter of CXP cable must be 4mm or more (core wire: copper single wire 23AWG (0.57φ)).

3.3.3 LED Indicator

- With LED indicator Active, lighting patterns show the camera status by its way of lighting.

LED lighting status	Descriptions
OFF	No power supply.
Green/Orange Fast blinking [12.5Hz]	Disconnection of cables.
Green Lighting	Completion of connection between device and host.
Green Fast blinking [12.5Hz] ※	Transmitting video data.
Orange Slow blinking [1Hz]	Waiting for a trigger input.
Red Fast blinking [12.5Hz]	Image transmission error, system error, or invalid frame occurred.

※ When TriggerMode is Off, the LED will blink with 12.5Hz. When TriggerMode is On, the LED will blink in trigger cycle.
(It may appear as lighted status at fast trigger mode.)

3.4. Spectral Response

※ Excludes characteristics of lens, IR cut filter, and light source.

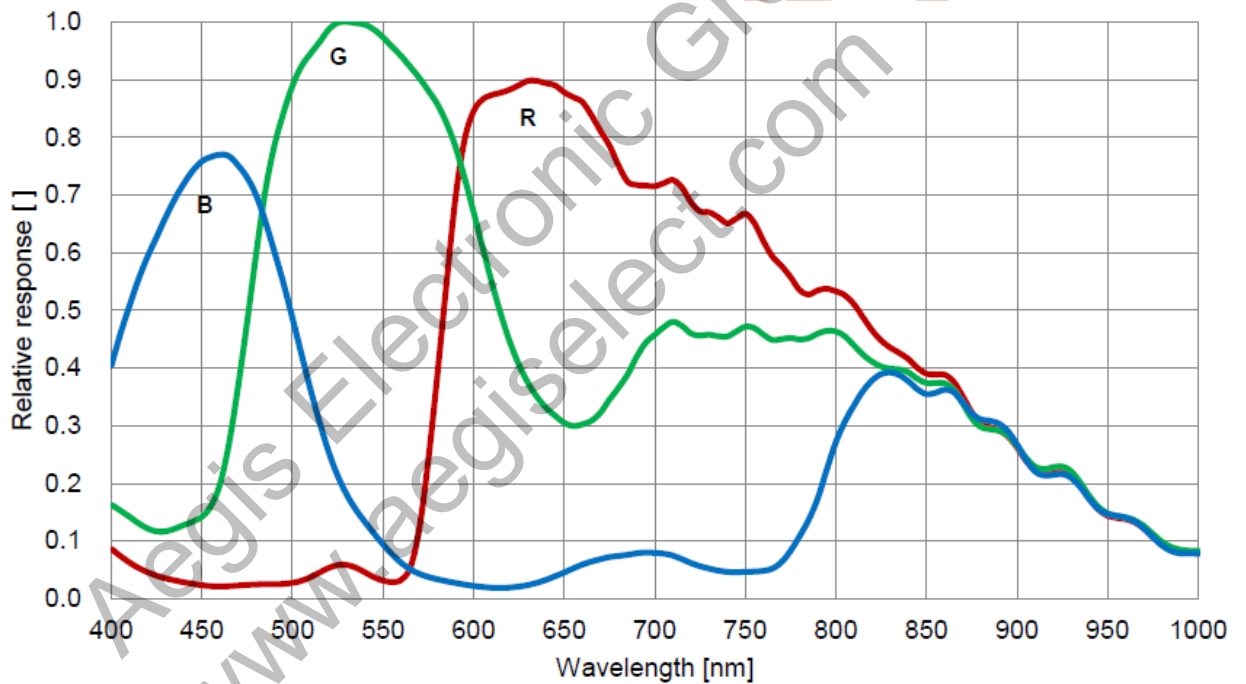

4.2. Vertical Sync Timing

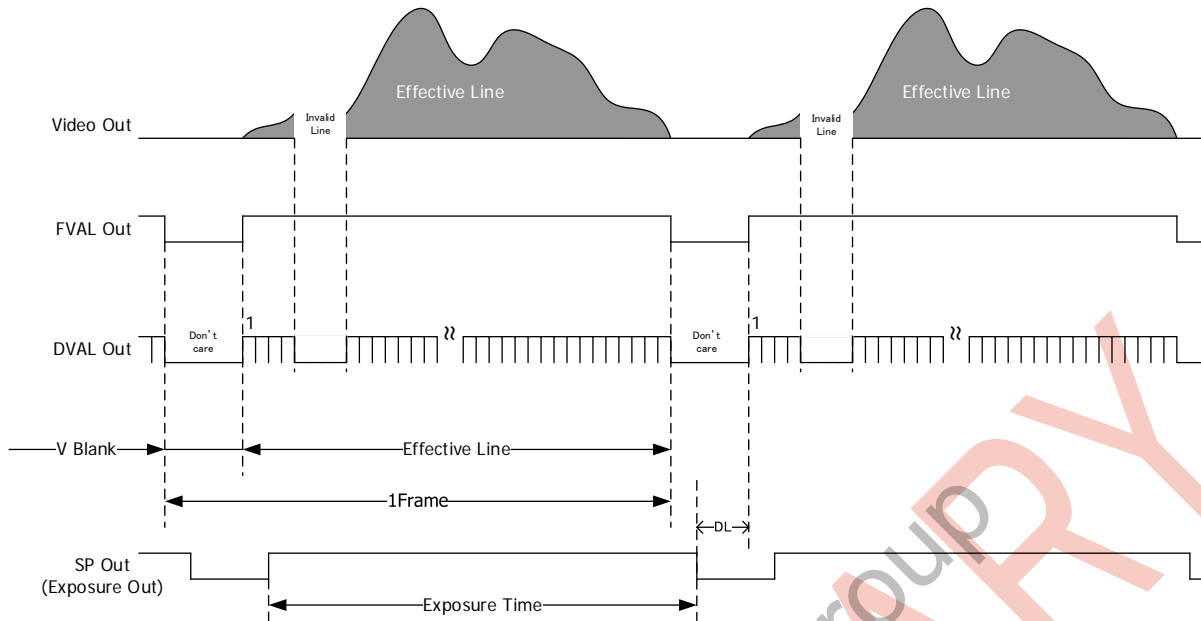

- ※ The time for 1 frame will change depends on the link rate and video output format.
- ※ The blanking line number for 1 frame will change depends on the link rate and video output format.

Effective line numbers and blanking line numbers

Link rate	Video output format	Effective line	V blank (Don't care)	1frame total line number	Time for 1H [us]	Time for 1 frame [ms]
CXP-12 x2Lane	Mono8, BayerRG8	4512	172	4684	2.68	12.55
	Mono10, BayerRG10	4512	164	4676	3.26	15.24
	Mono12, BayerRG12	4512	156	4668	3.78	17.65
CXP-12 x1Lane	Mono8, BayerRG8	4512	172	4684	3.89	18.22
CXP-6 x2Lane	Mono10, BayerRG10	4512	164	4676	4.94	23.10
	Mono12, BayerRG12	4512	156	4668	5.89	27.49
CXP-6 x1Lane	Mono8, BayerRG8	4512	172	4684	7.77	36.39
CXP-3 x2Lane	Mono10, BayerRG10	4512	164	4676	9.87	46.15
	Mono12, BayerRG12	4512	156	4668	11.76	54.90

Camera Internal clk 148.5 MHz

5. Camera Functions

5.1. Camera Interface

Complies with CoaXPress interface standard.

5.2. How to Save and Initialize Settings

UserSets	
UserSetSelector	Default UserSet0
UserSetLoad	Execute
UserSetSave	Execute

- Select UserSet0 with UserSetSelector and execute "UserSetSave" to save settings in operation into camera non-volatile memory.
 - ※ Settings cannot be saved to Default (factory settings).
 - ※ Values of UserSetSelector are not subject to save with UserSetSave. Please set values before executing UserSetLoad or UserSetSave.
- UserSetLoad loads Default (factory setting) or UserSet0 (user save area) selected with UserSetSelector.
 - ※ Do not execute UserSetLoad while grabbing (acquiring images).
- Camera keeps defective pixel correction values, shading correction values, and DeviceUserID even when UserSetLoad of Default is executed.
- ConnectionConfig and PixelFormat keep settings in operation even when UserSetLoad is executed. Therefore, please set them with commands.

UserSetSelector

Default	UserSetLoad >Excute	= Initialize(Factory setting)
UserSet0	UserSetLoad >Excute	= Initialize(User setting)
	UserSetSave >Excute	= User setting Save

5.3. Link Speed and Link Count

Transfer Control	
ConnectionConfig	CXP3_X2
	CXP6_X1
	CXP6_X2
	CXP12_X1
	CXP12_X2

- ◆ CXP3_X2: Link speed=3.125Gbps, Link count=2
- ◆ CXP6_X1: Link speed=6.250Gbps, Link count=1
- ◆ CXP6_X2: Link speed=6.250Gbps, Link count=2
- ◆ CXP12_X1: Link speed=12.50Gbps, Link count=1
- ◆ CXP12_X2: Link speed=12.50Gbps, Link count=2

※ Do not change ConnectionConfig while grabbing (acquiring images).

Transfer Control	
ConnectionReset	1

- ◆ Please reset ConnectionConfig / PixelFormat when switching.
- ◆ Write "1" to reset device so that it will reconnect automatically.
- ◆ Input other than "1" will be invalid.
- ◆ Please use after confirmed that the device is reconnected. It takes few seconds to reconnect.
- ◆ Following items cannot acquire values until reconnecting is completed. During that period, error might be shown. Please refresh indication to acquire correct values after reconnection.
 - DeviceTemperature
 - FpgaTemperature
 - IllegalTriggerFlag
 - BalanceWhiteAuto

5.4. Pixel Format

ImageFormatControl	
PixelFormat	BayerRG8
	BayerRG10
	BayerRG12
	Mono8
	Mono10
	Mono12

- ◆ BayerRG8 : Bayer 8bit
- ◆ BayerRG10 : Bayer 10bit
- ◆ BayerRG12 : Bayer 12bit
- ◆ Mono8 : Monochrome 8bit
- ◆ Mono10 : Monochrome 10bit
- ◆ Mono12 : Monochrome 12bit

※ Do not change PixelFormat while grabbing (acquiring images).

※ When set image flipping of X and Y direction, Bayer Pattern will also flip and RG, GR, GB, and BG settings at frame grabber board will change accordingly.

5.5. Trigger Mode

5.5.1 Internal Sync Mode (Free Run Mode)

- This is a mode to use internal triggers continuously generated.
- Turn off TriggerMode and set TriggerSelector to AcquisitionStart.
- The table below shows frame rate when ROI is disabled.

PixelFormat	Frame rate [fps]		
	CXP12_X2	CXP12_X1 CXP6_X2	CXP6_X1 CXP3_x2
Mono8, BayerRG8	79.6	54.8	27.4
Mono10, BayerRG10	65.6	43.2	21.6
Mono12, BayerRG12	56.6	36.3	18.2

5.5.2 External Trigger Sync Mode

- This is a mode to input external trigger signals to capture images by any preferred timings.
- Set TriggerSelector to AcquisitionStart and set TriggerSource to either Software/LinkTrigger0/Line0, and turn on TriggerMode.

Acquisition Control	
TriggerMode	On/Off
TriggerSyncMode	LineSync ClockSync
TriggerSelector	AcquisitionStart FrameStart
TriggerActivation	RisingEdge FallingEdge LevelHigh LevelLow
TriggerSource	Software LinkTrigger0 Line0
TriggerSoftware	Execute

- ◆ TriggerMode
 - ◆ On : Enable trigger selected with TriggerSource. (TriggerSelector = FrameStart)
 - ◆ Off : Disable trigger selected with TriggerSource. (TriggerSelector = AcquisitionStart)

※ Do not change TriggerMode while grabbing (acquiring) images.

- ◆ TriggerSyncMode
 - ◆ LineSync : H sync trigger mode (Control exposure time per line)
Fixed/pulse width trigger shutter mode
Overlapping operation (exposure while readout images) is valid.
 - ◆ ClockSync : CLK sync trigger mode (Control exposure time per sensor clock)
FAST fixed/FAST pulse width trigger shutter mode
Overlapping operation (exposure while readout images) is invalid.

※ Switch TriggerSyncMode when there is no trigger input.

※ Set free run mode (internal sync mode) after set to LineSync mode.

◆ TriggerSelector

This is to select how to start capturing video or its polarity out of the followings.

- ◆ AcquisitionStart : Free run mode (Internal sync mode)
- ◆ FrameStart : External trigger mode
- ※ Do not change TriggerSelector while grabbing (acquiring images).

◆ TriggerActivation

This is to select how to start capturing video or its polarity out of the followings.

- ◆ RisingEdge : Fixed trigger shutter mode: Rising edge (Timed)
- ◆ FallingEdge : Fixed trigger shutter mode: Falling edge (Timed)
- ◆ LevelHigh : Pulse width trigger shutter mode: High active (TriggerWidth)
- ◆ LevelLow : Pulse width trigger shutter mode: Low active (TriggerWidth)

◆ TriggerSource

This is to select where to send external triggers.

- ◆ Software : External trigger input from TriggerSoftware command.
- ◆ LinkTrigger0 : External trigger input from CoaXPress Host Device.
Please refer to specification manuals of the Host Device such as frame grabber board to know how to generate triggers.
- ◆ Line0 : External trigger input from 12pins circular connector.

◆ TriggerSoftware : Software trigger

Camera generates a trigger to capture one frame image by executing this command.

Make sure to set TriggerSource to Software.

- ※ TriggerSoftware is valid when TriggerActivation is Rising Edge.

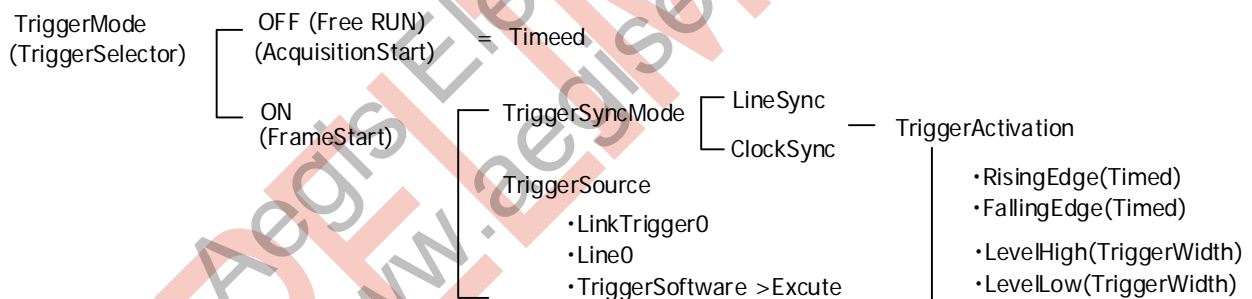

5.6. Trigger Sync Mode and Delay Time to Start Exposure

- H sync trigger mode (LineSync):
1H of jitter may occur from inputting trigger to exposure. (Overlapping operation is valid.)
- CLK sync trigger mode (ClockSync):
Less delay time from trigger input, and the precise trigger operation is valid. (Overlapping operation is invalid.)

Trigger sync mode and delay time to start exposure

	CXP12_X2	CXP12_X1 CXP6_X2	CXP6_X1 CXP3_X2
Delay time to start exposure with H sync trigger (LineSync)	Approx. 20~21H	Approx. 20~21H	Approx. 20~21H
Delay time to start exposure with CLK sync trigger (ClockSync)	Approx. 0.1us	Approx. 0.1us	Approx. 0.1us

5.7. Restrictions on Trigger Pulse Input Timing

- User can input a trigger for the next frame while camera is reading out signals. However, do not input a trigger pulse to end exposure while camera is reading out signals. In other words, a trigger pulse to start reading out signals for the next frame before completion of reading out signals for the prior frame is restricted.

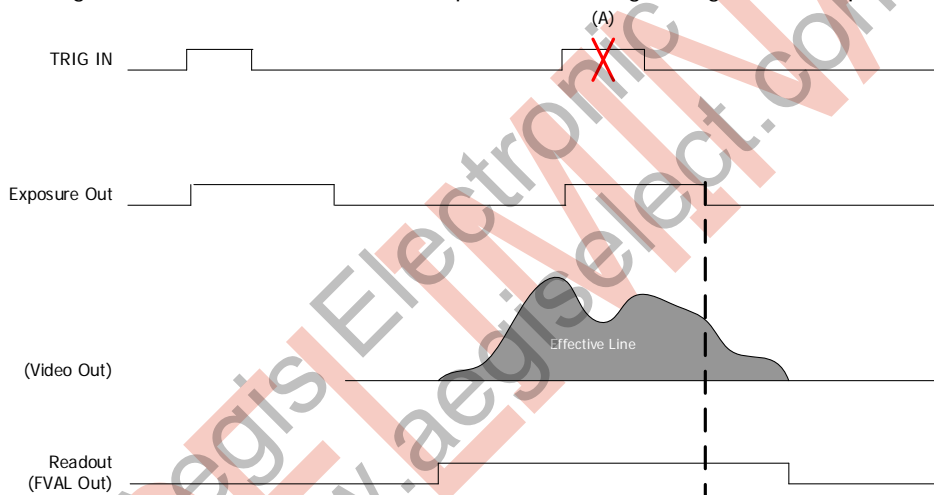

- If there is a trigger input with restricted timing explained in the above, "IllegalTriggerFlag" becomes "1".

Acquisition Control	
IllegalTriggerFlag	0 or 1

Device Control	
ErrorFlagReset	Execute

This is to reset IllegalTriggerFlag to "0".

5.8. Fixed Trigger Shutter Mode (LineSync) H Sync Trigger

(TriggerMode=On, TriggerSyncMode=LineSync, TriggerActivation=RisingEdge)

- This is a mode to start exposure with external trigger input and expose for a set period.
- Trigger operation is H sync V sync reset.
The delay time (Exposure Time Delay) from detecting trigger edge in the camera to starting exposure is 20H~21H with full frame scan.
- 1H jitter will occur to Exposure Time Delay since external trigger signal synchronizes with H inside the camera.
Trigger pulse width to input must be longer than 1H. (Please refer to 1 line width for each mode in the table below.)

Time for 1 line

PixelFormat	Time for 1 line of link rate [us]		
	CXP12_X2	CXP12_X1 CXP6_X2	CXP6_X1 CXP3_X2
Mono8, BayerRG8	2.68	3.89	7.77
Mono10, BayerRG10	3.26	4.94	9.87
Mono12, BayerRG12	3.78	5.89	11.76

- There is an exposure time period for approx. **2.46µs** at the edge right after exposure output.

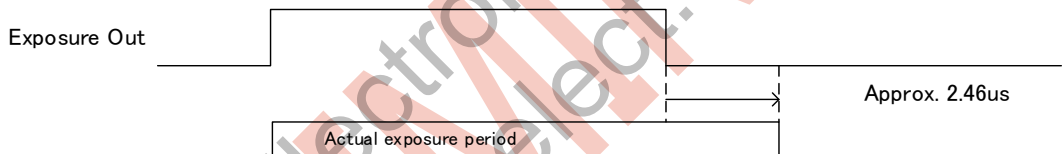

- User can input a trigger while camera is outputting images. However, do not input a trigger signal to start outputting next images before completion of outputting the prior images.
- Trigger input while exposure period (Exposure Time) will be ignored in the camera. ((A) in the drawing below)
Do not use a trigger shorter than 1 frame cycle.

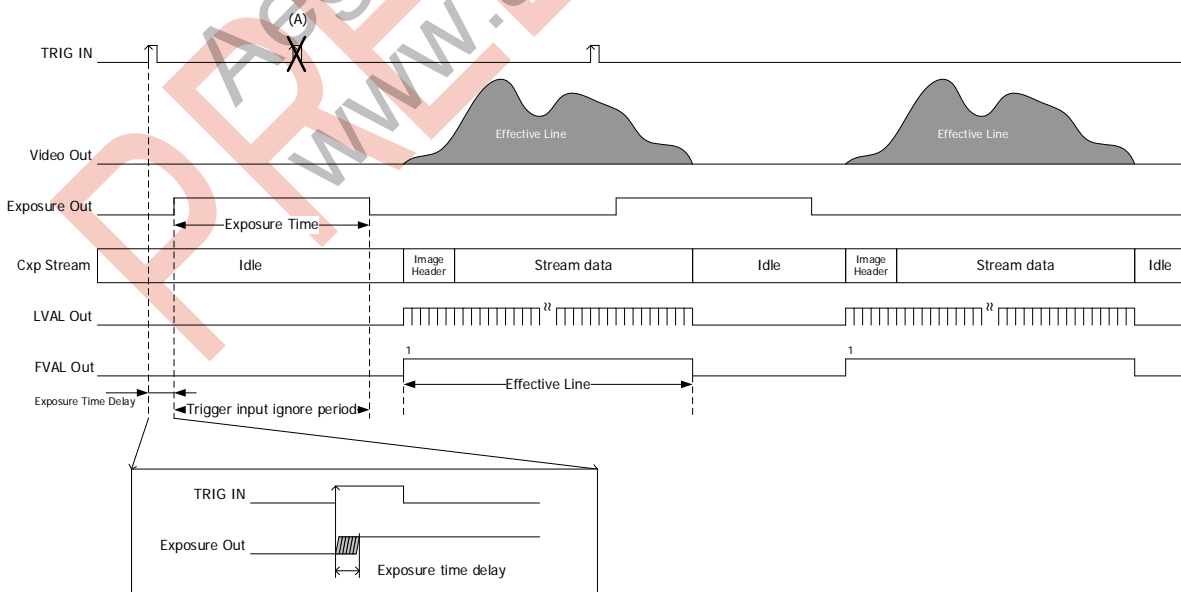

5.9. FAST Fixed Trigger Shutter Mode (ClockSync) CLK Sync Trigger
 (TriggerMode=On, TriggerSyncMode=ClockSync, TriggerActivation=RisingEdge)

- This is a mode to start exposure with external trigger input and expose for a set period.
- Trigger operation is CLK sync V sync reset.
 The delay time (Exposure Time Delay) from detecting trigger edge in the camera to starting exposure is approx. 0.1us. Trigger pulse width to input must be longer than 1us.
- The delay time to end exposure will depend on the settings of each mode. (Please refer to the delay time for each mode in the table below.)

Exposure time delay of each mode

PixelFormat	Exposure time delay of link rate [us]		
	CXP12_X2	CXP12_X1 CXP6_X2	CXP6_X1 CXP3_X2
Mono8, BayerRG8	42.6	62.0	124.1
Mono10, BayerRG10	51.9	78.8	157.7
Mono12, BayerRG12	60.3	93.9	187.9

- There is an exposure time period for approx. **2.46μs** at the edge right after exposure output.

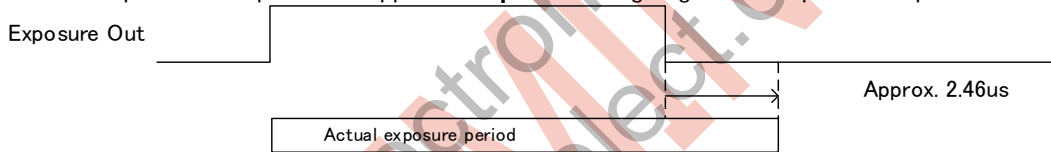

- The next trigger input while outputting images cannot be accepted.
- Trigger input while exposure period (Exposure Time) and readout period will be ignored in the camera. ((A) and (B) in the drawing below)

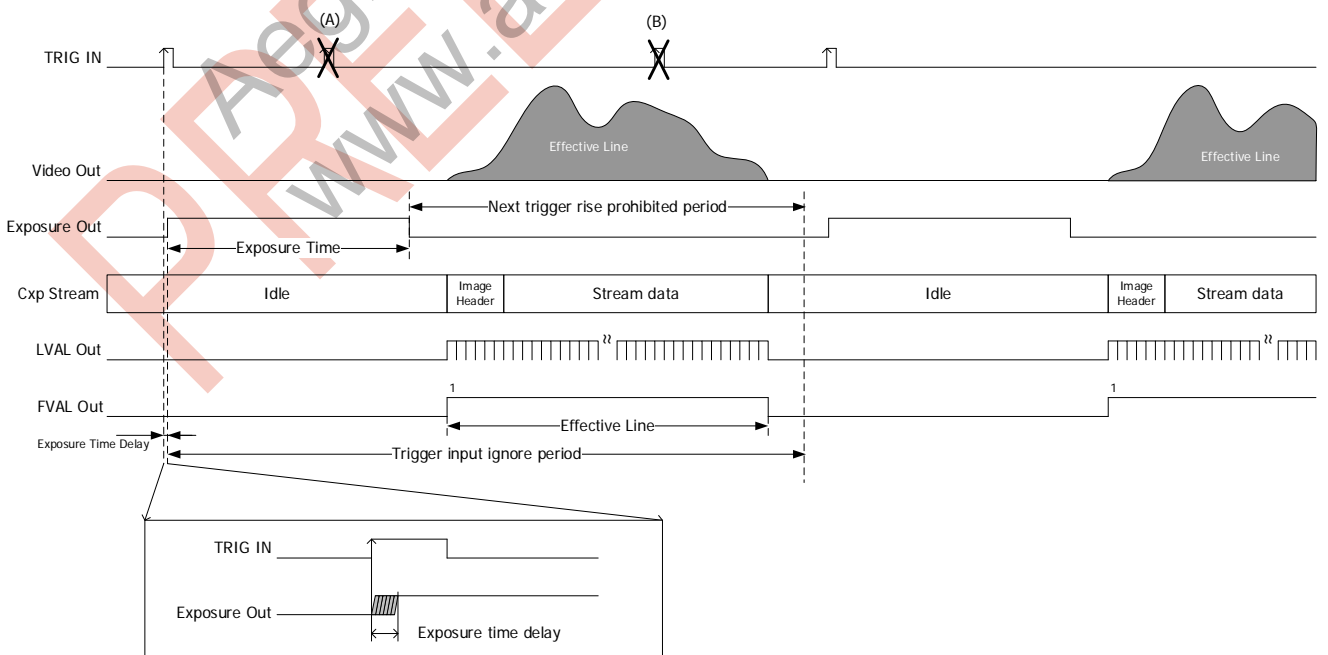

5.10. Pulse Width Trigger Shutter Mode (LineSync) H Sync Trigger
(TriggerMode=On, TriggerSyncMode=LineSync, TriggerActivation=LevelHigh)

- This is a mode to start exposure with external trigger input and set exposure time with pulse width of trigger signals.
- Trigger operation is H sync V sync reset.

The delay time (Exposure Time Delay①) from detecting trigger edge in the camera to starting exposure is **20H~21H** with full frame scan.

- The delay time (Exposure Time Delay②) from detecting the trigger edge in the camera to end exposure is **20H~21H+2.46 us.**

- Approx. 1H jitter will occur to Exposure Time Delay ① and ② since external trigger signal synchronizes with H inside the camera. Jitters may occur at both start and end edges of exposure with pulse width trigger shutter mode. At this time, exposure time will change so that flicker may be shown in the image, especially when high speed shutter is set. This flicker sometimes can be eliminated with fixed trigger shutter mode. However, this problem can be solved by inputting trigger pulse with synchronizing it to the camera H cycle (LVAL).

- Pulse width 1H (Min.) ~ Approx. 2 frames

Functionally, there is no upper limitation, but noises such as dark noise shadings may be noticeable at long time exposure.

- There is an exposure time period for approx. **2.46μs** at the edge right after exposure output.

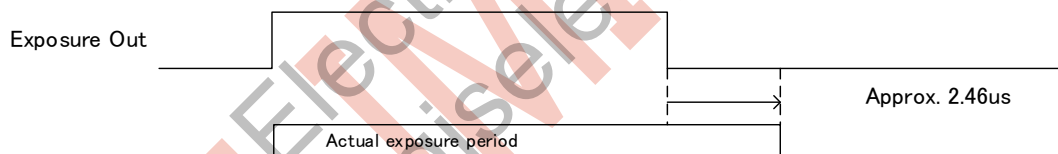

- Trigger input while exposure period (Exposure Time) will be ignored in the camera. Do not use a trigger shorter than 1 frame cycle.
- User can input a trigger while camera is outputting images. However, do not input a trigger signal to start outputting next images before completion of outputting the prior images. ((A) of TRIG IN in the next page)

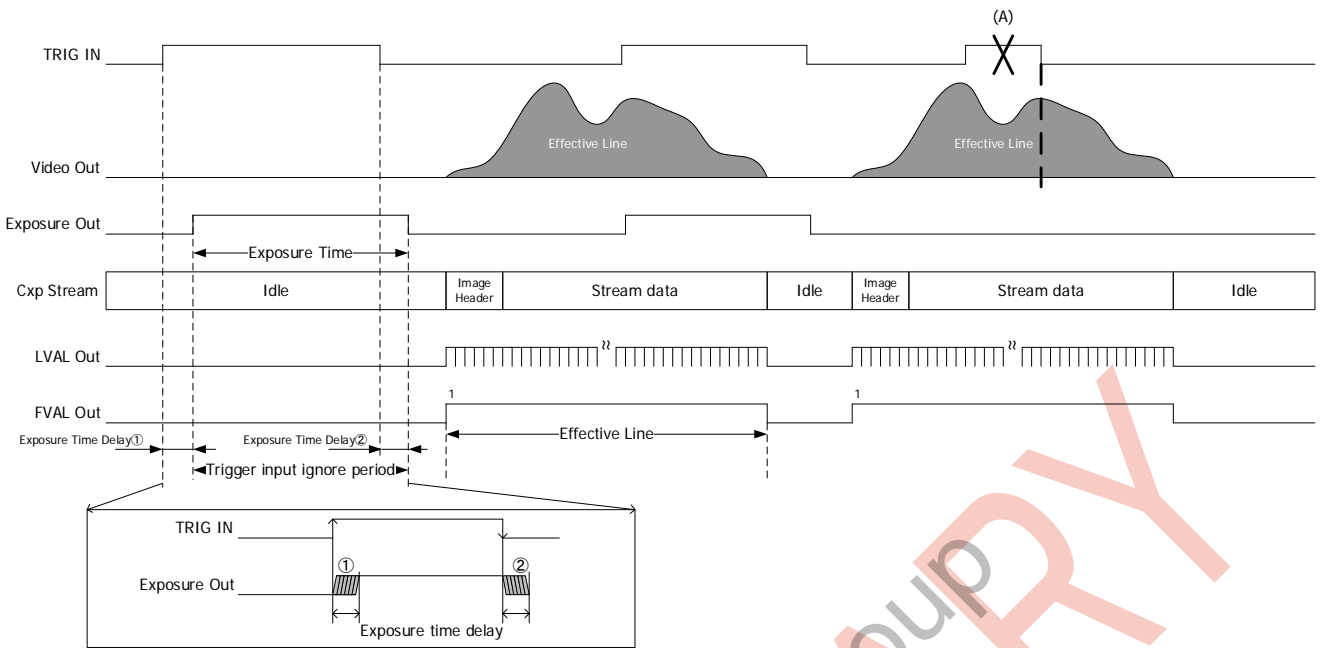

5.11. FAST Pulse Width Trigger Shutter Mode (ClockSync) CLK Sync Trigger

(TriggerMode=On, TriggerSyncMode=ClockSync, TriggerActivation=LevelHigh)

- This is a mode to start exposure with external trigger input and set exposure time with pulse width of trigger signals.
- Trigger operation is CLK sync V sync reset.

The delay time (Exposure Time Delay①) from detecting trigger edge in the camera to starting exposure is **approx. 0.1us**.

- The delay time (Exposure Time Delay②) from detecting trigger edge in the camera to end exposure will depend on the settings of each mode.

Exposure time delay of each mode

PixelFormat	Exposure time delay of link rate [us]		
	CXP12_X2	CXP12_X1 CXP6_X2	CXP6_X1 CXP3_X2
Mono8, BayerRG8	42.6	62.0	124.1
Mono10, BayerRG10	51.9	78.8	157.7
Mono12, BayerRG12	60.3	93.9	187.9

- There is an exposure time period for **approx. 2.46μs** at the edge right after exposure output.

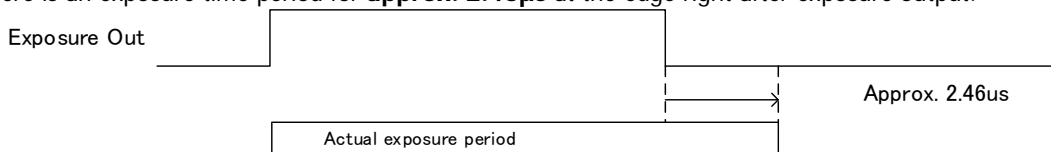

- Pulse width **0.74us** (Min.) ~ Approx. 2 frames

Functionally, there is no upper limitation, but noises such as dark noise shadings may be noticeable at long time exposure.

☐ Trigger input while readout period will be ignored in the camera. ((A) of TRIG IN in the drawing below)

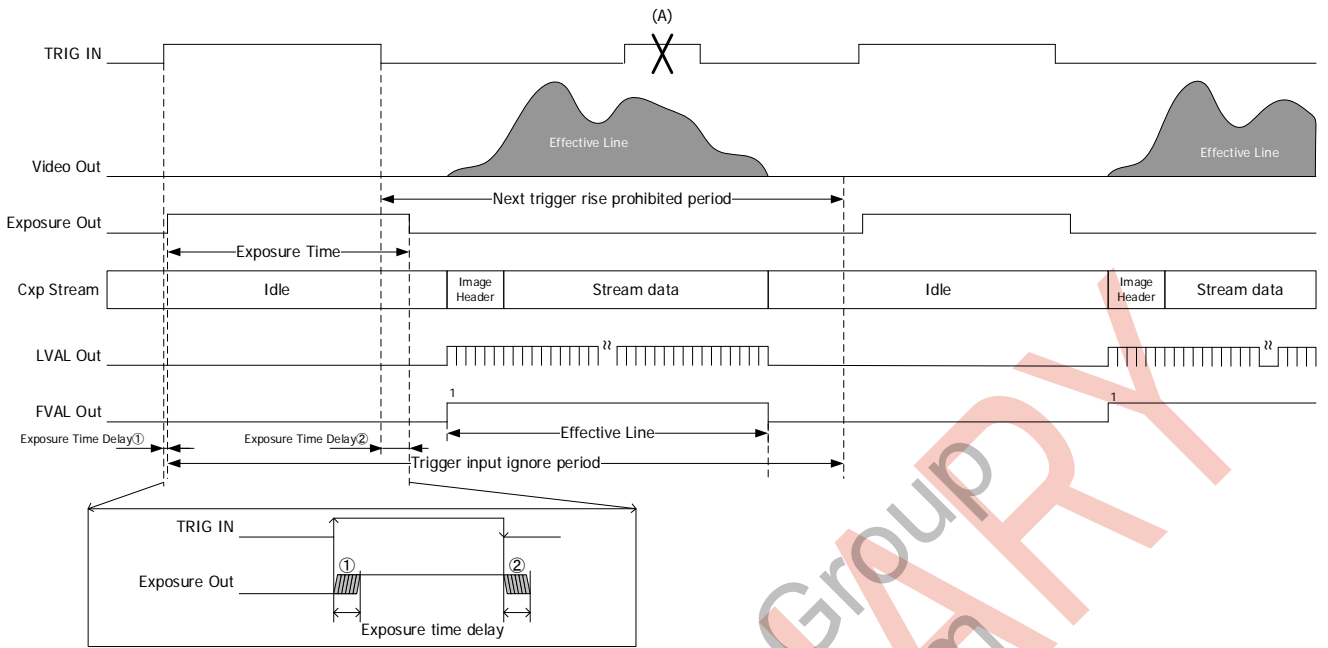

5.12. Exposure Time

Acquisition Control	
ExposureMode	Timed TriggerWidth
ExposureTime (us)	2.68us~Max. exposure time: LineSync 10us~200ms: ClockSync
ExposureTimeMax	(ReadOnly)

ExposureMode (Read only): This is to check if current mode is Timed or TriggerWidth (PWC).

ExposureTime : Exposure time (Valid when ExposureMode is Timed.)

- Set per 1H when the trigger operation is H sync. It will return the value (us) rounded by 1H per Min. 1H mode.

- Set per approx. 1us when the trigger operation is CLK sync.

ExposureTimeMax : Max. exposure time

- Set the smaller value than ExposureTimeMax when the camera is internal sync mode.

It will depend on partial scan (ROI) settings, PixelFormat, and link rate.

※ The maximum of H sync trigger mode (LineSync) will be clipped with effective line count (Including when the camera is set to ROI).

※ CLK sync trigger mode (ClockSync) can be set in the range of 10us~200ms. It will not be clipped with effective line count.

5.13. Formula to Calculate Manual Shutter Values with H Sync Mode

The value will be corrected to the value corresponds to the following formula.

Formula: Exposure time = Time for 1 line (Please refer to the table below) × Exposure line count + **2.46us**

Time for 1 line

PixelFormat	Time for 1 line of link rate [us]		
	CXP12_X2	CXP12_X1 CXP6_X2	CXP6_X1 CXP3_X2
Mono8, BayerRG8	2.68	3.89	7.77
Mono10, BayerRG10	3.26	4.94	9.87
Mono12, BayerRG12	3.78	5.89	11.76

※ The Min. setting value will be clipped with 1, and the Max. value will be clipped with 4512 or with the total line count of partial mode.

5.14. Manual Shutter Settings with CLK Sync Mode (FAST Trigger Mode)

Exposure time = Setting value + **2.46us**

- Min. setting value: **10us** (Approximate value)
- Max. setting value: **200ms** (Approximate value)
 - ※ Unlike H sync mode, exposure time will not be clipped with total line count, etc.
 - ※ Bright point may be noticeable with long time exposure.
- Setting unit: 1us (Approximate value) ※ Slight differences may occur since it is generated by 74.25MHz.

5.15. Gain

AnalogControl	
Gain	1.00~64.00

Functionally, up to x64.00 can be set, however with high gain settings, noise will increase and image quality deteriorates.

5.16. Gamma Correction

AnalogControl	
Gamma	0.10~1.80

Gamma: This is to set gamma correction value per 0.01 step.

[Note]

Camera updates gamma table at the timing of image output.

With continuous operation mode, camera applies the updated gamma table at the timing of image output after completion of rewriting gamma table (approx. 20ms: refer to Command ACK as a rough guide).

If user changes gamma coefficient while waiting for a trigger input, camera outputs images with updated gamma table with a trigger after completion of rewriting gamma table.

5.17. Partial Scan (ROI)

- This is to increase frame rate by cutting and reducing read out area.
- It will be Idle output when RegionMode of Region 1~8 are all OFF.
- User can select up to 8 areas for partial area.

ImageFormatControl	
RegionSelector	EffectiveRegion, Region1~8
RegionMode	On/Off
RegionDestination	Stream0
Width	4512
Height	16~4512 (Multiples of 16)
OffsetX	0
OffsetY	0~4504 (Multiples of 16)

- RegionSelector : This is to select Region to set.
User can set 8 partial areas with Region 1~8. Select EffectiveRegion to check Width and Height of the effective partial area.
※ Make sure to set RegionSelector to EffectiveRegion to start capturing images.
- RegionMode : On/Off of the Region1~8. User can check if there is an effective region with EffectiveRegion.
※ Enabled only when Width, Height, OffsetX, and OffsetY are effective.
- RegionDestination : Selection of Stream to output. Fixed with Stream0.
- Width : Width of Region. This model VCC-20CXP6R is fixed to 4512/8bit and 4480/10,12bit.
- Height : Height of Region
※ Make sure that OffsetY and Height do not overlap with other regions.
- OffsetX : Offset for X direction of Region. This model VCC-20CXP6R is fixed to 0.
- OffsetY : Offset for Y direction of Region.
※ Make sure that OffsetY and Height do not overlap with other regions.

In case of setting 3 partial areas:

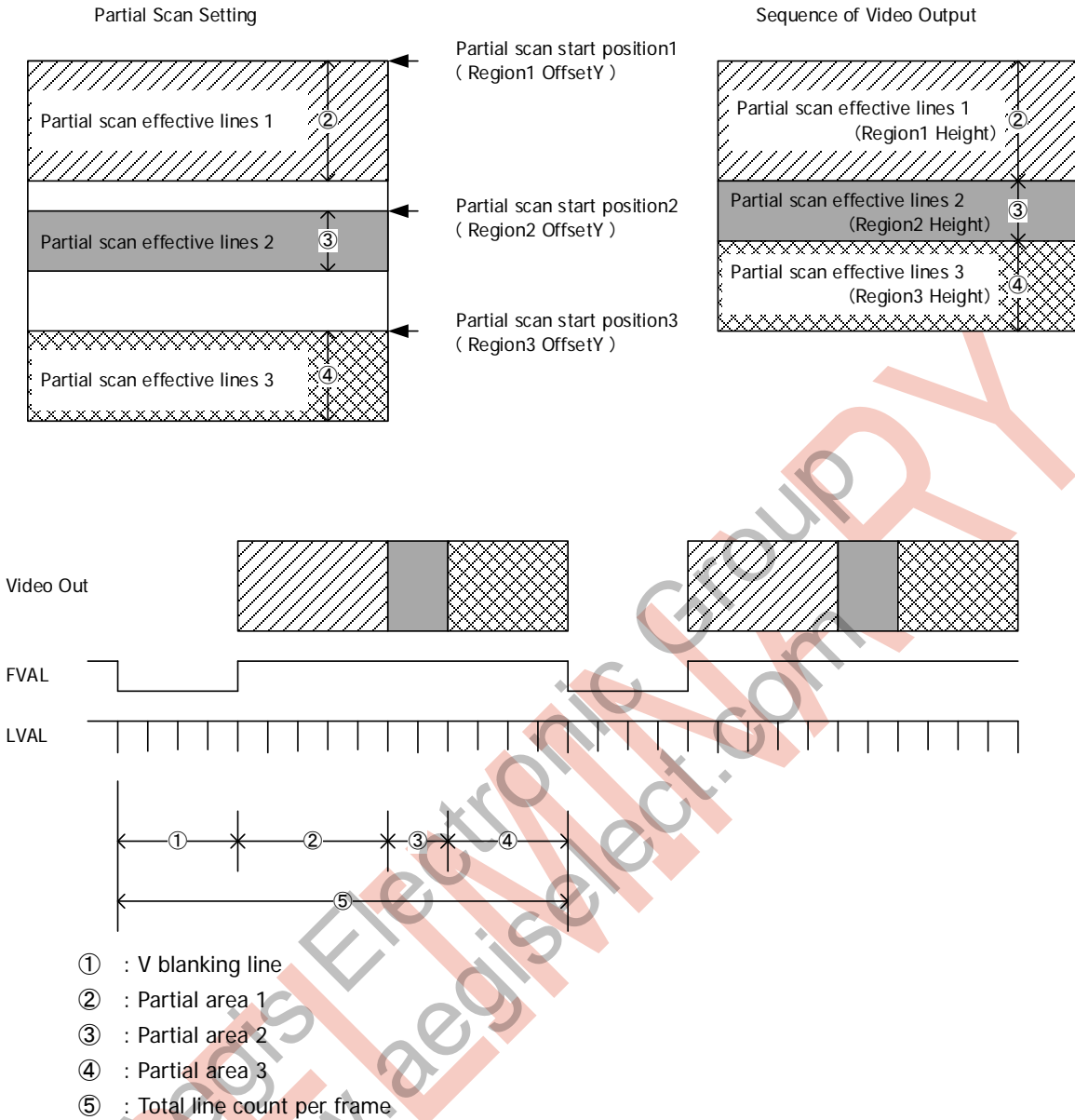

When setting several partial scan areas, make sure that start positions and effective lines do not overlap each area.

- V blanking lines with partial scan mode will be **172(mono8) or 164(mono10) or 156(mono12)H.**
 - Total line count per frame = V blanking lines + Partial effective line 1 + Partial effective line 2 + ... + Partial effective line 8
- However, make sure that sum total of partial effective line numbers from 1~8 (except V blanking lines) is less than 4512.
- Frame rate = 1 / (Total line count per frame × Time for 1 line)

Time for 1 line

PixelFormat	Time for 1 line of link rate [us]		
	CXP12_X2	CXP12_X1 CXP6_X2	CXP6_X1 CXP3_X2
Mono8, BayerRG8	2.68	3.89	7.77
Mono10, BayerRG10	3.26	4.94	9.87
Mono12, BayerRG12	3.78	5.89	11.76

- The line numbers with partial scan setting can be set from 16 lines. Only multiple numbers of 16 can be set.
- With partial scan, the effective line count of manual shutter setting becomes the maximum value (except at ClkSync trigger).
- When switch between Full frame scan mode and Partial scan mode, or changing partial settings, 1 frame after the change will be invalid.

Especially with fixed trigger shutter mode and pulse width trigger shutter mode, input a dummy trigger first, then use subsequent triggers as actual video signals.

5.18. White Balance

AnalogControl	
BalanceRatioSelector	Red Blue
BalanceWhiteAuto	Off Once
BalanceRatio	1.00~8.00

- BalanceWhiteAuto: This is to adjust white balance gain automatically.
 - Off : Waiting
 - Once : Adjust white balance automatically with one push.
 Select "Once" of BalanceWhiteAuto to adjust white balance automatically and return to off.
 BalanceRatio shows new gain of color component selected with BalanceRatioSelector.
 Shoot an object with achromatic color to full screen to execute BalanceWhiteAuto. Recommendation is approx. 50% of signal level to execute.

※Set RegionSelector to EffectiveRegion to execute "Once" of BalanceWhiteAuto.

※More than 2 partial areas disable BalanceWhiteAuto.

Enables the following commands only when BalanceWhiteAuto is OFF.

- BalanceRatioSelector : This is to select the color component you wish to change with BalanceRatio.
- BalanceRatio : This is to set gain in the range of x1 ~ x8.
 If user set Red with BalanceRatioSelector, set BalanceRatio to 1.0, then change BalanceRatioSelector to Blue, and set BalanceRatio to 1.0, white balance becomes invalid.

5.19. Black Level Adjustment

- This is to adjust black level of image sensor.

AnalogControl	
BlackOffset	-256~255

[Note]

This is not a function to set absolute value of black level.

Black level of image sensor can be changed proportionally.

User can change setting values while capturing images. However, disturbance images may occur.

5.20. Image Quality Selecting Mode

- This is to select image quality of output image.

AnalogControl	
ImageQualityMode	StandardMode LowFrameRateMode

- ◆ ImageQualityMode : Image quality selecting mode
 - ◆ StandardMode : Standard mode
 - ◆ LowFrameRateMode : SN will be improved compared to StandardMode, however the frame rate and sensitivity will be decreased.
Frame rate will be the same as the camera with 10bit.
Valid only with Mono8 and BayerRG8.

5.21. Shading Correction

- This is to correct the drop in the amount of peripheral light caused by lens and others.

AnalogControl	
ShadingCorrectionDataSelector	Off/Table1/Table2/Table3
DetectShading	(Execute)

- ◆ ShadingCorrectionDataSelector:

Select shading correction Off or shading correction table to use.
When selecting Table1 - Table3, correction function will be ON according to each correction value.
※ Please note that ShadingCorrectionDataSelector cannot be executed when setting several partial scan areas.
- ◆ DetectShading:

Select Table1- Table3 and execute DetectShading to acquire correction data in the designated Table.
Please make sure to turn off partial scan when detecting, and shoot an object with stable brightness such as pattern box, to full screen.
Execute UserSetSave to save the correction data.

Before shading correction



After shading correction



[Note]

- Acquire correction data only when camera is in operation. Acquisition of shading correction data is invalid when there is no output from camera.
- When executing UserSetSave, Correction data of Table1~ Table3 will be saved in the camera non-volatile memory at the same time.
- Camera will maintain correction data even executed Default with UserSetLoad.
- Make sure to reacquire correction data when executed vertical flip.

5.22. Flip

ImageFormatControl	
ReverseX	True/False
ReverseY	True/False

- ◆ ReverseX : Flip the image of X direction.
- ◆ ReverseY : Flip the image of Y direction.

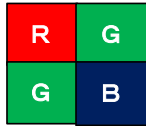

Bayer Pattern: RGGB

※When set flipping for X and Y direction with RAW model, bayer pattern will also flip. RG, GR, GB, and BG of grabber board setting will change accordingly.

[Note]

- Please make sure that ReverseX is PixelFormat = image width (4480) of Mono10/12.
ReverseX = False (Before flipping) does not indicate OffsetX = 4480 - 4511.
ReverseX = True (After flipping) does not indicate OffsetX = 4480 - 4511 (Before flipping OffsetX = 0 - 31).
- Please be careful for the setting procedure (combination) of flip and ROI of ReverseY.
Please set the value of OffsetY and Height of ROI with ReverseY = False (Before flipping).
When set to ReverseY = True (After flipping), the current OffsetY and Height of ROI will be updated to the value after flipping.

5.23. Defective Pixel Correction

- This is a function to detect and correct defective pixels in output data from the sensor.
- There are two types of defective pixel data.
 - Defective data registered at factory
Black and white defective pixel data registered upon shipment from our factory.
These data cannot be over-written.
 - Defective data registered by user
Data registered by user. In addition to the correction of defective pixel data registered upon shipment, we provide a method to update the defective pixel data. With DefectPixelDefault command, user can delete these user-registered data.
- With normal operation and H&V flipping, defective pixel correction information are saved separately.
(The position and the number of defective pixels are different with normal operation and H&V flipping)

- User can register up to 768 points.
[Note] Up to 64 points per CH.

[CH (Channel)]

Camera performs image processing with 12CH interleave.

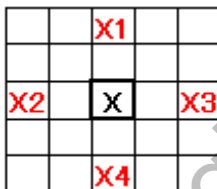
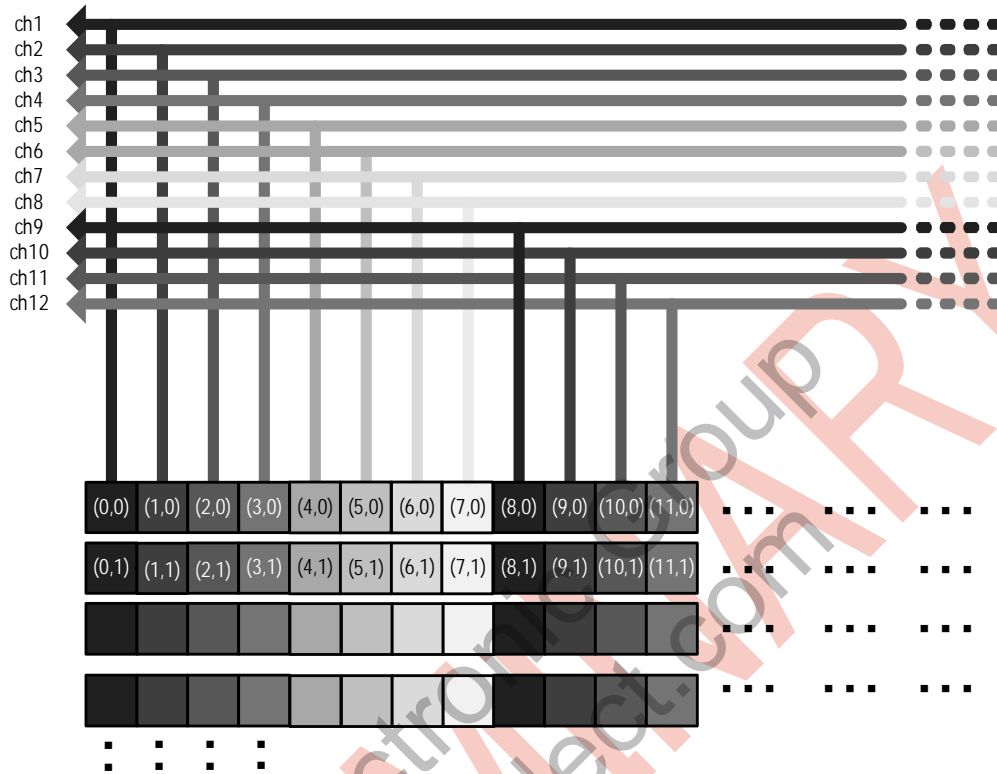

Defective pixel correction function calculates value for X pixel referring to peripheral pixels (up and down, left and right).

When all peripheral pixels, X1, X2, X3, and X4, are already registered as defective pixels, user cannot correct the X pixel.

- How to control defective pixel correction
This is to turn ON/OFF defective pixel correction processing.
Defective pixel correction data at factory and defective pixel correction data registered by user will be both controlled at the same time.

AnalogControl	
DefectPixelCorrection	On/Off
DefectPixelAddOffsetY	0~4511
DefectPixelAddOffsetX	0~4511
DefectPixelAdd	(Execute)
DefectPixelDelete	(Execute)

- Defective data registered by user
This is to add the designated X and Y coordinate.

Any preferred pixels can be registered and deleted as defective pixels by designating coordinates.

- DefectPixelCorrection : This is to select valid/invalid of defective pixel correction.
 - DefectPixelAddOffsetY : Designate Y coordinate
 - DefectPixelAddOffsetX : Designate X coordinate
 - DefectPixelAdd : Please execute DefectPixelAdd to register the designated coordinate as a defective pixel correction point.
 - DefectPixelDelete : Please execute DefectPixelDelete to delete the designated coordinate registered as defective pixel correction point.
- ◇ When user registers or deletes defective pixels, Region number of ROI needs to be 1 with full frame (4512x4512/8bit, 4480x4512/10/12bit).
 - ◇ If the coordinate same as defective data at factory is designated, it will be ignored.
 - ◇ User can delete only the defects added by "Defective pixel detection registered by user" or "Defective pixel added by user". Factory setting data cannot be deleted by this command.

Defective pixel detection registered by user

This is to detect and register correction data of white defect caused by image sensor.

AnalogControl	
DefectCorrectMode	Reacquire/Add
DefectDetectionThesholdValue	0~4095
DefectDetection	(Execute)
DefectDetectionStatus	(ReadOnly)
DefectPixelDefault	(Execute)

- ◆ DefectCorrectMode : This is to set detection mode of defective pixels.
 - Reacquire mode: This mode deletes defective pixel data except those added by one point addition and reacquire defective pixels.
 - Add mode: This mode acquires defective pixels in addition to the current pixels registered.
- ◆ DefectDetectionThesholdValue: This is to set a threshold value (0~4095: 12bit equivalent) for user defective pixel detection. Data which exceeds the luminance level designated here will be registered. With 8bit images, designate a value of 16 times of signal level as a threshold value.
- ◆ DefectDetection: This is to detect defective pixels registered by user. Function automatically registers pixels that exceed the level designated with DesignefectDetectionThresholdValue. Make sure to shield light from image sensor to execute. Function reflects defective pixel correction registered by user immediately after execution. Execute UserSetSave after DefectDetection to save data into non-volatile memory.
- ◆ DefectDetectionStatus: This is to indicate results of defective pixel detection proceeded by user.

0	No defective pixel correction data registered by user.
Value (384 or less)	When the function operates normally. (Number of defective pixels detected and registered by user.)
0x000e0001 (917505)	Total number of defective pixel correction data exceeds the maximum number to register. (768 points)
0x000e0002 (917506)	Total number of defective pixel correction data exceeds the maximum number to register in one CH. (64 points)

When the value 768 or more is indicated, check if user threshold value (DefectDetectionThresholdValue) and the indication of defective pixels are appropriate.

※Please note that error may be indicated in decimal depends on the frame grabber board to use.

- ◆ DefectPixelDefault : This is to delete entire defective pixel correction data registered by user.

[Note]

- ◆ Make sure to acquire defective pixel correction data when camera is in operation.
- ◆ Make sure to turn OFF partial scan. (Execute defect detection with a size of 4512×4512.)
- ◆ To acquire user defective pixel correction data by changing threshold value of DefectDetectionThresholdValue, execute DefectPixelDefault first to delete defective pixel correction data registered by user and reacquire it.
- ◆ Maximum number of defective pixels to register and to correct may not always be the same due to following reasons.
 - (1) With white defects detection, if one of interleave channel reaches the maximum number of defective pixels to register, correction stops. Function registers data up to that point, outputs error, and ends operation.
 - (2) When there is no effective pixel around the pixel to add (on the left, right, top, and bottom), user can register but cannot correct that pixel.

□ Indication of defective pixel coordinates

This is to indicate the coordinates of defective pixels registered by user.

AnalogControl	
RegisteredDefectSelector	UserState/InitialState
RegisteredDefectNumber	(ReadOnly)
DefectPixelNumber	1 ~ 768
DefectPixelOffsetY	(ReadOnly)
DefectPixelOffsetX	(ReadOnly)
DefectPixelType	(ReadOnly)

- ◆ RegisteredDefectSelector : This is to select the types of registered defects.
- ◆ RegisteredDefectNumber : This is to indicate the number of corrected defective data registered at factory and by user.
- ◆ DefectPixelNumber : This is to designate a table number of the defective data registered at factory and by user.
- ◆ DefectPixelOffsetY : This is to indicate Y coordinate of the defective pixel designated with DefectPixelNumber. When user designated a table number with no defective pixel data, it shows 65535.
- ◆ DefectPixelOffsetX : This is to indicate X coordinate of the defective pixel designated with DefectPixelNumber. When user designated a table number with no defective pixel data, it shows 65535.
- ◆ DefectPixelType : This is to indicate the types of defects designated with DefectPixelNumber.
 - 1: White defects registered upon shipment from factory
 - 2: Black defects registered upon shipment from factory
 - 6: Defects registered by user
 - 7: Defects additionally registered by user
 - 65535: Table without defects

AnalogControl	
ChannelNumber	1~12
DefectPixelChannelCount	(ReadOnly)

- ChannelNumber : This is to designate channel number of defective pixel correction.
- DefectPixelChannelCount : Indicate the number of defective pixels for the channel number and types (registered at factory or by user) specified with ChannelNumber and RegisteredDefectSelector. The number of defective pixel of the designated channel number is the sum total of defective pixel number upon shipment and the number of defective pixels registered by user.

5.24. Test Pattern Indication

- This is to output test pattern from camera. This is useful to check if your system is operating properly.

ImageFormatControl	
TestPattern	Off ColorBar ColorBarMoving

※ Test pattern indication cannot be used when cursor is indicated.

5.25. Cursor Indication

- This is to show cursor on your display screen.

ImageFormatControl	
CursorPattern	Off/On
CursorOffsetX	0~4511
CursorOffsetY	0~4511
CursorColor	White/Black

※ Cursor indication cannot be used when test pattern is indicated.

- CursorPattern : Cursor indication On/Off.
- CursorOffsetX : X coordinate of vertical cursor.
- CursorOffsetY : Y coordinate of horizontal cursor.
- CursorColor : This is to select the color of cursor. (black or white)

[Note]

The camera will output White or Black with 1dot and 1line, however it will shown as colored due to the bayer interpolation at viewer side. Also, the color will be shown differently with each position.

5.26. LED Operational Mode

- This is to change operational mode of LED at the rear of camera. For information on lighting patterns, refer to [Section 3.3.3. LED Indicator](#).

DeviceControl	
DeviceIndicatorMode	Active ErrorStatus Inactive

- Active : Indication of communication status of CoaXPress.
- ErrorStatus : OFF with normal operation. Lights only with system error occurred.
- Inactive : ALL LED OFF

5.27. Camera Timing Output

- According to LineSelector and LineSource settings, camera outputs the following signals through pin No. 6 and No. 7 of 12pins circular connector.

Digital IO Control	
LineSelector	Line1 / Line2
LineMode	Output
LineSource	OFF ExposureActive FrameActive LineActive TriggerPacketActive

- LineSelector
Line1: This is to select output settings of No. 6 pin.
Line2: This is to select output settings of No. 7 pin.
- LineSource
This is to set output settings of 12pins circular connector selected with LineSelector.

Off : No timing output.
 ExposureActive : This is to output exposure period of image sensor with Hi Active.
 FrameActive : This is to output effective period of frame with Hi Active.
 LineActive : This is to output effective period of video output line with Hi active.
 TriggerPacketActive : This is to decode and output packet signals of uplink trigger from frame grabber.

5.28. User ID

- Set a letter string as DeviceUserID with up to 16 characters including NUL letter (¥0). Execute UserSetSave to save these letter strings to camera non-volatile memory. These data will be kept even executing "UserSetLoad" with "Default."

DeviceControl	
DeviceUserID	Manual

5.29. Temperature Indication

- This is to indicate temperature of image sensor (=DeviceTemperature) and FPGA (=FpgaTemperature) (°C).

DeviceControl	
DeviceTemperature	(ReadOnly)
FpgaTemperature	(ReadOnly)

[Note] The value of register is not calibrated. Please regard it as reference value.

6. Factory Settings

Function	Data	Descriptions
TriggerSelector	AcquisitionStart	Equivalent to TriggerMode=Off
TriggerMode	Off	Operate with TriggerSelector at the same time.
TriggerSyncMode	LineSync	Horizontal sync mode
TriggerSource	LinkTrigger0	UP link trigger
TriggerActivation	RisingEdge	Rising edge
ExposureTime	35062.94	35062.94us
Gain	1.00	x1.00
Gamma	1.00	Gamma coefficient=1.00
DefectPixelCorrection	On	Defective pixel correction On
DefectPixelAddOffsetX	0	X coordinate of defective pixel
DefectPixelAddOffsetY	0	Y coordinate of defective pixel
DefectDetectionThesholdValue	4095	Threshold value of defective pixel detection
BlackOffset	0	Black level initial value
PixelFormat	BayerRG8	RAW model
ConnectionConfig	CXP6_X1	CxpLinkConfiguration
TestMode	NomalOperation	Link test Off
RegionSelector	EffectiveRegion	Designate the number for partial area (ROI) (Region1)
RegionMode	On	Partial area (ROI) operation On/Off
Height	4512	Designate the height of partial area (ROI).
OffsetY	0	Designate the start position of partial area (ROI)
TestPattern	Off	Cannot use cursor indication at the same time.
CursorPattern	Off	Cannot use test pattern at the same time.
CursorOffsetX	2256	Position of cursor X
CursorOffsetY	2256	Position of cursor Y
CursorColor	White	Cursor color White
BalanceRatioSelector	Red	RAW model
BalanceWhiteAuto	Off	RAW model
BalanceRatio	1.00	RAW model
ReverseX	False	Horizontal flip OFF
ReverseY	False	Vertical flip OFF
ShadingCorrectionDataSelector	Off	Shading correction OFF
DeviceIndicatorMode	Active	Indicate LED indicator
LineSource	Off	12pins circular connector No. 6 and No. 7 pin output settings.
DeviceUserID		User set letter string (16 letters)

7. Dimensions

7.1. Camera Dimensions

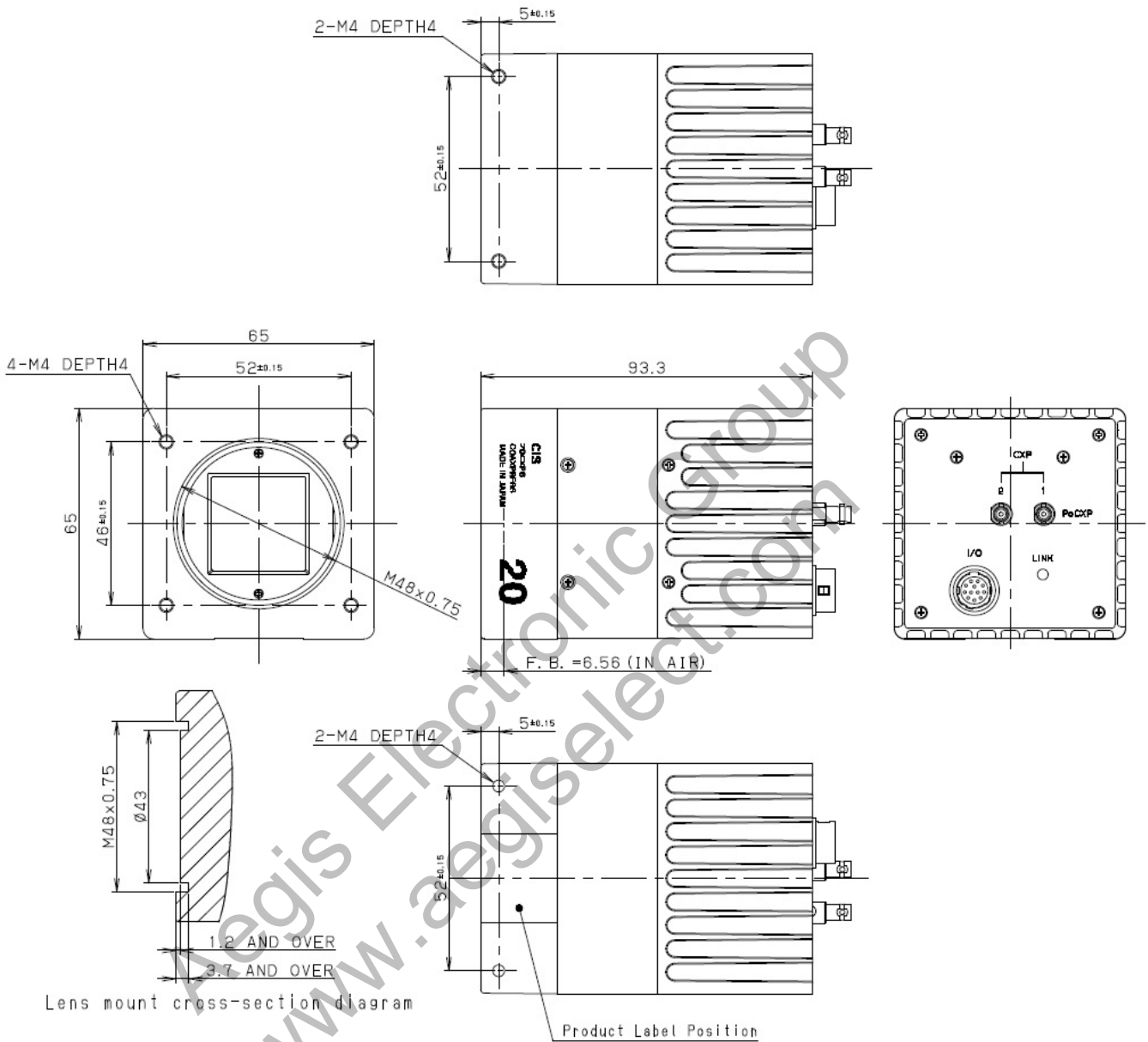

Note2) Lens mount screw complies with M48x0.75-6H.
Please refer to J11A LE-004-2011.

Note1) Please make sure the protrusion portion does not interfere with the lens selected.
Refer to the lens mount cross-section diagram for the details.

935-0175-00
(Unit:mm)

7.2. Optical Axis Accuracy

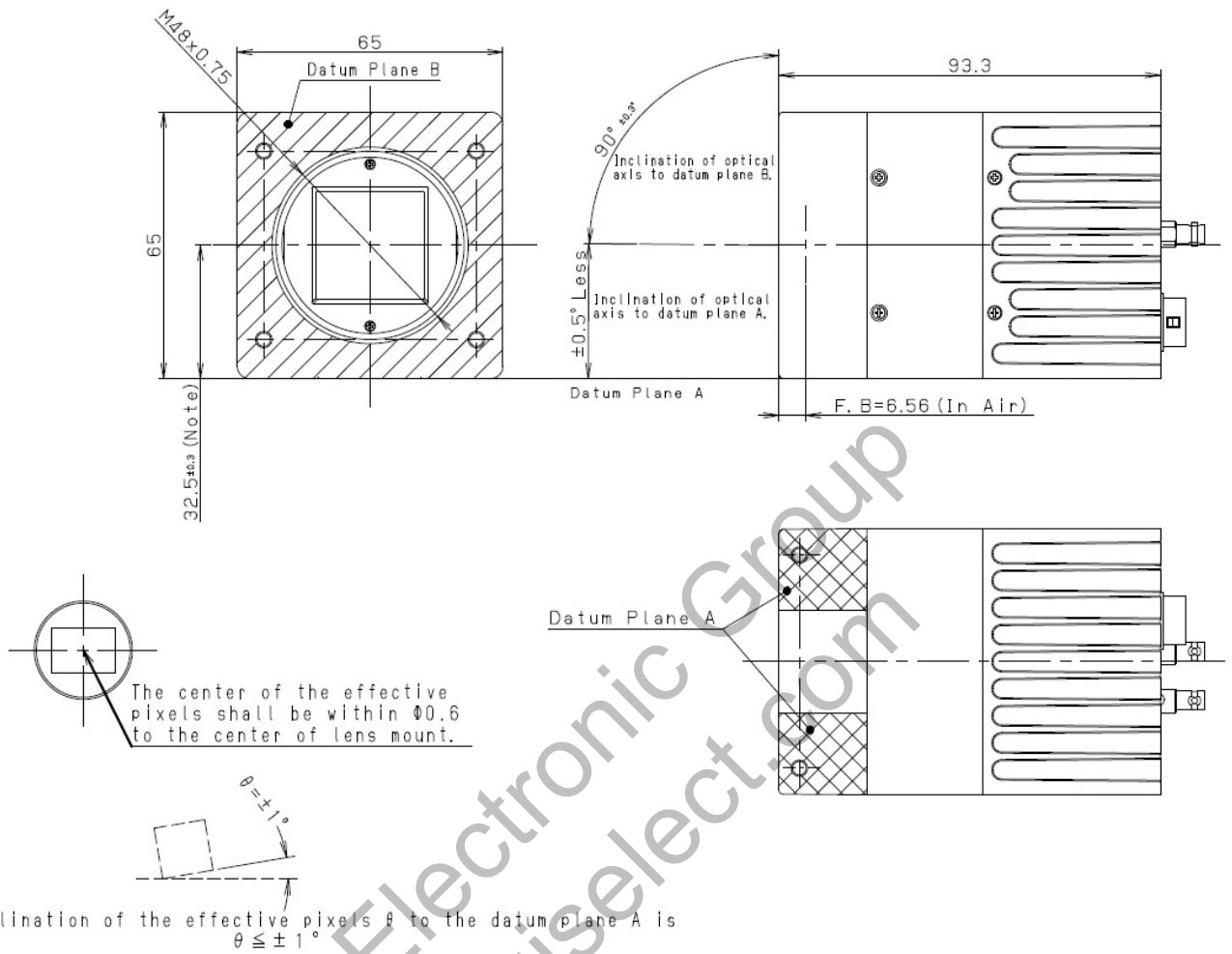

Note) Dimensions from datum plane A to the center of the lens mount.

937-0034-00
(Unit: mm)

8. Case for Indemnity (Limited Warranty)

8.1. Product Warranty

The term of warranty of this product is within 3 years from the date of shipping out from our factory.

If you use the product properly and discover a defect during the warranty period, and if that was caused by designing or manufacturing, CIS Corporation, at its option, repairs or replaces it at no charge to you. Products out of warranty period will be subject to charge.

CIS should not hold responsible for damages or losses if;

- damages or losses are caused by earthquake, lightning strike, fire, flood or other acts of God.
- damages or losses are caused by deliberate or accidental misuse by user, or failure to observe the information contained in the instructions in this Product Specification and Operational Manual.
- damages or losses are caused by repair or modification conducted by customer or any unauthorized party.

8.2. CMOS Defective Pixels

CIS applies defective pixel correction prior to the shipment of the product. However, the number of defective pixels are subject to increase due primarily to the effect of cosmic rays. Due to this nature, CIS should not hold responsible for the natural increase of defective pixels.

8.3. Product Support

Should you have any problems in function of the product you purchased, and if you need our further analysis and/or repair, please contact your local distributor.