

# CIS

CoaXPress I/F  
12M pixels CMOS (B/W) Camera

## VCC-12CXP4M

Product Specifications  
& Operational Manual

**CIS Corporation**

## Table of Contents

1.	Handling Precautions .....	1
1.1.	Camera Handling Precautions .....	1
1.2.	Restrictions on Applications .....	1
1.3.	Disclaimers (Exception Clause) .....	1
2.	Product Outline .....	2
2.1.	Features .....	2
3.	Specifications .....	3
3.1.	General Specifications .....	3
3.2.	Input and Output Specifications .....	4
3.3.	External Connector Pin Assignment .....	5
3.3.1	6pins Circular Connector (I/O) .....	5
3.3.2	75Ω BNC Connector .....	5
3.3.3	LED Indicator .....	5
3.4.	Spectral Response .....	6
4.	Camera Functions .....	6
4.1.	Camera Interface .....	6
4.2.	How to Save and Initialize Settings .....	6
4.3.	Link Speed and Link Count .....	7
4.4.	Pixel Format .....	7
4.5.	Flip .....	7
4.6.	Internal Sync. Mode (Free Run Mode) .....	8
4.7.	External Trigger Mode .....	8
4.8.	Trigger Sync Mode and Delay Time to Start Exposure .....	10
4.9.	Restrictions on Trigger Pulse Input Timing .....	10
4.10.	Fixed Trigger Shutter Mode (LineSync) H Sync. Trigger .....	11
4.11.	FAST Fixed Trigger Shutter Mode (ClockSync) CLK Sync. Trigger .....	12
4.12.	Pulse Width Trigger Shutter Mode (LineSync) H Sync. Trigger .....	13
4.13.	FAST Pulse Width Trigger Shutter Mode (ClockSync) CLK Sync. Trigger .....	14
4.14.	Exposure Time .....	15
4.15.	Formula to Calculate Manual Shutter Values with H Sync. Mode .....	15
4.16.	Manual Shutter Settings with CLK Sync. Mode (FAST Trigger Mode) .....	16
4.17.	Gain .....	16
4.18.	Gamma Correction .....	16
4.19.	Black Level Adjustment .....	16
4.20.	Partial Scan (ROI) .....	17
4.21.	2×2 Binning Mode .....	19
4.22.	Shading Correction .....	20
4.23.	Defective Pixel Correction .....	20
4.24.	Test Pattern Indication .....	24
4.25.	Cursor Indication .....	24
4.26.	LED Operational Mode .....	24
4.27.	Camera Timing Output .....	24
4.28.	User ID .....	25
4.29.	Temperature Indication .....	25
5.	Factory Settings .....	26
6.	Dimensions .....	27
6.1.	Camera Dimensions .....	27
6.2.	Optical Axis Accuracy .....	28

---

---

7.	Case for Indemnity (Limited Warranty).....	29
7.1.	Product Warranty.....	29
7.2.	CMOS Defective Pixels.....	29
7.3.	Product Support.....	29

Aegis Electronic Group  
www.aegiselect.com

## 1. Handling Precautions

### 1.1. Camera Handling Precautions

- Do not use or store camera in dusty or humid places.
- Do not apply excessive force, vibration, or static electricity that could damage camera. Please handle camera with care.
- Do not shoot direct images that are extremely bright (e.g., strong light source, sun, etc.). When extremely strong light source is shot, smear or blooming may occur. Put the lens cap on when camera is not in use.
- Follow the instructions in [Chapter 3.3., "External Connector Pin Assignment"](#) for connecting camera. Improper connection may cause damages not only to the camera but also to the connected devices.
- Confirm mutual ground potential carefully before connecting camera to monitors or computers. Any AC leak from the connected devices may cause damages or destroy the camera.
- Do not apply excessive voltage. (Use only the specified voltage.) Unstable or improper power supply voltage may cause damages or malfunction of the camera.
- Our warranty does not apply to damages or defects caused by irregular and/or abnormal use of the product.

**Our warranty does not apply to damages or defects caused by neglecting the instructions and precautions explained in this manual.**

### 1.2. Restrictions on Applications

- The camera must not be used for any nuclear equipment or aerospace equipment with which mechanical failure or malfunction could result in serious bodily injury or loss of human life.
- The camera must not be used under conditions or environments other than those specified in this manual.

### 1.3. Disclaimers (Exception Clause)

CIS should not be liable for any damages or losses if;

- damages or losses are caused by earthquake, lightning strike, fire, flood, or other acts of God.
- damages or losses are caused by deliberate or accidental misuse by user, or failure to observe information and instructions explained in this manual.
- damages or losses are caused by repair or modification conducted by user or any unauthorized party.

#### **[Notes on heat dissipation]**

CIS recommend customer to use lens with M42 mount or F mount (by using conversion ring) for heat dissipation. Using 4pcs of M4 screw at the camera front to fix the camera on a metal frame also helps for effective heat dissipation.

## 2. Product Outline

VCC-12CXP4M is B/W camera with CoaXPress interface. Using 1.1", global shutter type 12M pixels CMOS image sensor. Complies with CoaXPress Version 1.1.1. Must have function ready for Machine Vision applications such as trigger shutter, ROI, Gain, black level adjustment, defective pixel correction, and PoCXP. Suitable for various FA/Machine vision applications.

### 2.1. Features

- Dimensions: 55mm(H) x 55mm(W) x 30mm(D)
- Global shutter type CMOS sensor
- Complies with CoaXPress CXP-3 and CXP-6
- 2 lanes or 1 lane
- Exposure setting, Gain setting
- External trigger mode (Fixed trigger shutter mode / Pulse width trigger shutter mode)
- Complies to GenICam
- M42 lens mount

Aegis Electronic Group  
www.aegiselect.com

## 3. Specifications

## 3.1. General Specifications

<b>Electrical Specifications</b>			
Image sensor	Sensor type	1.1", Global shutter type CMOS sensor	
	Effective pixels	4096(H) × 3000(V)	
	Unit cell size	3.45μm(H) × 3.45μm(V)	
Interface		Complies with CoaXPress 1.1.1 Supports CXP6/CXP3 x2/1 lane	
Pixel clock frequency		74.25MHz	
Video output format		Mono 8 / Mono 10	
Frame rate	CXP3 8bit/10bit 1 lane	16.2fps	
	CXP3 8bit/10bit 2 lanes	32.3fps	
	CXP6 8bit/10bit 1 lane	32.3fps	
	CXP6 8bit/10bit 2 lanes	64.7fps	
Sync system		Internal sync.	
Resolution (The maximum pixel size)		4096 (H) × 3000(V)	
Video signals (Gain 0dB)	White clip level	255dig	with 8bit
	Set up level	2±2dig	with 8bit
	Dark shading	4dig or less for both horizontal and vertical	with 8bit
Sensitivity		F5.6 400lx (Shutter speed 1/27s, Gain 0dB)	
Minimum illumination		F1.4 0.3lx (Gain +36dB, Shutter speed 1/27s, level=50%)	
Gain variable range		x1~x64 (0dB ~ +36dB) [Guarantee range]	
Shutter speed		Manual setting	
Trigger mode		Free run mode (Camera internal trigger) Trigger mode (Host, External terminal) • Fixed trigger shutter • Pulse width trigger shutter	
Partial scan		Vertical 8 areas can be set.	
Power requirements		PoCXP: 18.5~26V	
Power consumption (typ)		4.3W (CXP-6) [with free run]	
<b>Mechanical Specifications</b>			
Dimensions		H:55mm W:55mm D:30mm excluding projection.	
Weight		Approx. 120g	
Lens mount		M42 mount	

Environmental Specifications			
Safety/Quality Standards			
UL: Complies with UL Standard including materials. CE: EMC: 2014/30/EU Emission: EN61000-6-4:2007+A1:2011 Immunity: EN61000-6-2:2005			
RoHS: 2015/863/EU EN50581 (RoHS2)			
Durability	Vibration	Acceleration	: 98m/s <sup>2</sup> (10G)
		Frequency	: 20 ~ 200Hz
		Direction	: X, Y, and Z 3 directions
		Testing time	: 120min for each direction
	Shock	No malfunction with 980m/s <sup>2</sup> (100) G for ±X, ±Y, and ±Z, 6 directions without packaging.	
Operational temperature		0 ~ +45°C Humidity: 20 ~ 80%RH with no condensation.	
Storage temperature		-30 ~ +60°C Humidity: 20 ~ 80%RH with no condensation.	

### 3.2. Input and Output Specifications

#### □ 3pins SIGNAL\_OUT circuit

This is to output timing signals generated in the camera. Set the signal to output with LineSource of Digital IO Control.

- 5.0V logic level output
- Output voltage Low: 0.55Vdc (Max), High: 3.8Vdc (Min)

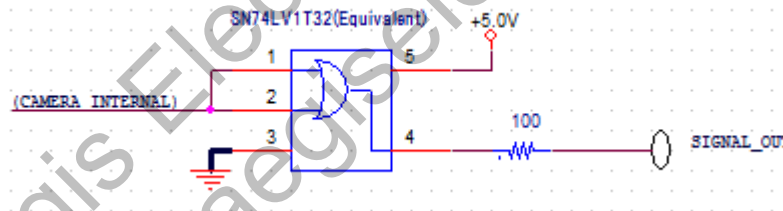

#### □ 5pins TRIGGER\_IN circuit

Triggers can be input directly from the external equipment. To use this terminal, set TriggerSource of AcquisitionControl to Line0.

- 5.0V, 3.3V logic level input (TTL-compatible)
- Voltage Low: 0.5Vdc (Min), High: 2.1Vdc (Max)

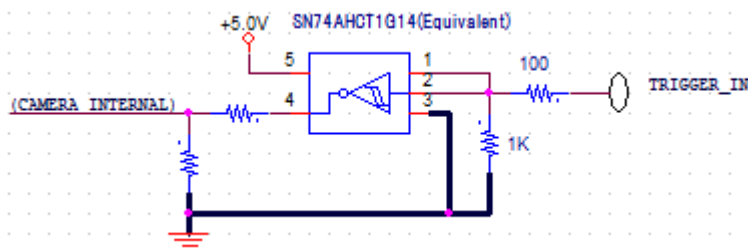

### 3.3. External Connector Pin Assignment

#### 3.3.1 6pins Circular Connector (I/O)

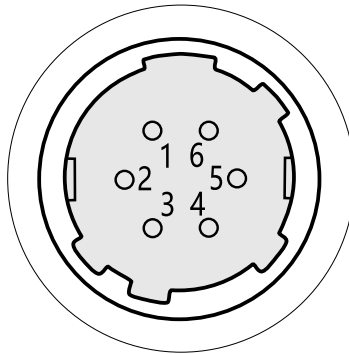

HR10A-7R-6PB (Hirose) or equivalent

Pin No.	Signals	Description
1	NC	
2	NC	
3	SIGNAL_OUT	Exposure/FVAL/LVAL/LinkTrigger
4	NC	
5	TRIGGER_IN	Trigger input
6	GND	Electrically connected with camera chassis.

※NC=Non-Connection. Do not connect anything to the terminal.

#### 3.3.2 75Ω BNC Connector

- Image output signal of CoaXPress.
- CXP1 is a connector for PoCXP.

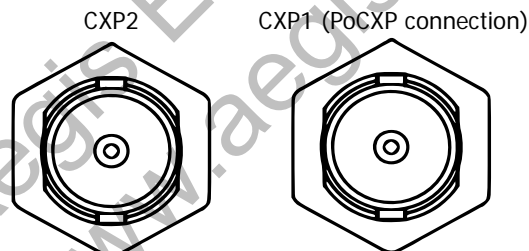

#### 3.3.3 LED Indicator

- With LED indicator Active, lighting patterns show the camera status by its way of lighting.

OFF	No power supply.
Green/Orange fast blinking [12.5Hz]	1pc of cable is not connected.
Green lighting	Completion of connection between device and host.
Green fast blinking [12.5Hz]	Transmitting video data.
Orange slow blinking [1Hz]	Waiting for a trigger input.
Red fast blinking [12.5Hz]	System error occurred.

### 3.4. Spectral Response

※ Excludes characteristics of lens, optical glass, and light source.

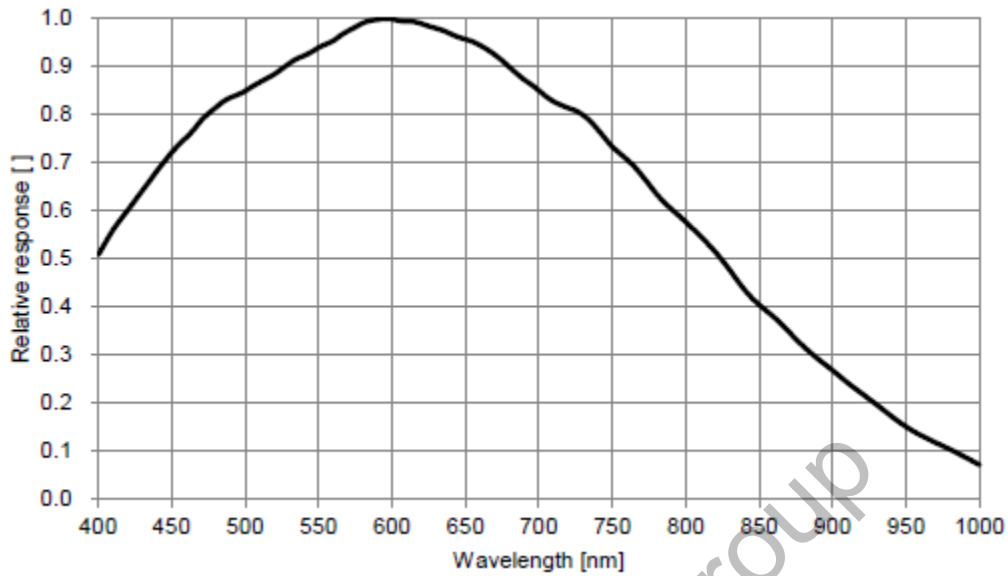

## 4. Camera Functions

### 4.1. Camera Interface

- Complies with CoaXPress interface standard.

### 4.2. How to Save and Initialize Settings

UserSetControl	
UserSetSelector	Default UserSet0
UserSetLoad	Execute
UserSetSave	Execute

- Select UserSet0 with UserSetSelector and execute "UserSetSave" to save settings in operation into camera non-volatile memory.
  - Default (factory settings) is not subject to save.
  - Values of UserSetSelector are not subject to save with UserSetSave. It will be always set to Default when the power is on. Please set values before executing UserSetLoad or UserSetSave.
- UserSetLoad loads Default (factory setting) or UserSet0 (user save area) selected with UserSetSelector.
  - ※ Do not execute UserSetLoad while grabbing (acquiring images).
- Shading correction values, defective pixel correction values, and UserID are not subject to UserSetLoad for Default. (Camera keeps those values).

- ConnectionConfig and PixelFormat keep settings in operation even when executing UserSetLoad. Therefore, please set them with commands.

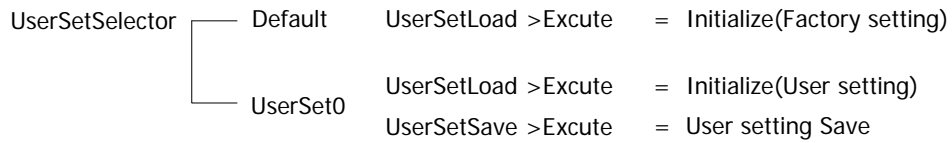

4.3. Link Speed and Link Count

Transfer Control	
ConnectionConfig	CXP3_X1
	CXP3_X2
	CXP6_X1
	CXP6_X2

CXP3: Link speed = 3.125Gbps, Link count = 1 or 2

CXP6: Link speed = 6.250Gbps, Link count = 1 or 2

※Do not change ConnectionConfig while grabbing (acquiring images).

4.4. Pixel Format

ImageFormatControl	
PixelFormat	MONO8
	MONO10

MONO8: Monochrome 8bit

MONO10: Monochrome 10bit

※Do not change PixelFormat while grabbing (acquiring images).

4.5. Flip

ImageFormatControl	
ReverseX	True/False
ReverseY	True/False

ReverseX: Flip the image of X direction.

ReverseY: Flip the image of Y direction.

※Do not change flip setting while grabbing (acquiring image).

4.6. Internal Sync. Mode (Free Run Mode)

- This is a mode to use internal triggers continuously generated.
- Turn off TriggerMode and set TriggerSelector to AcquisitionStart.
- ※ Please set TriggerSyncMode to LineSync to use this mode.

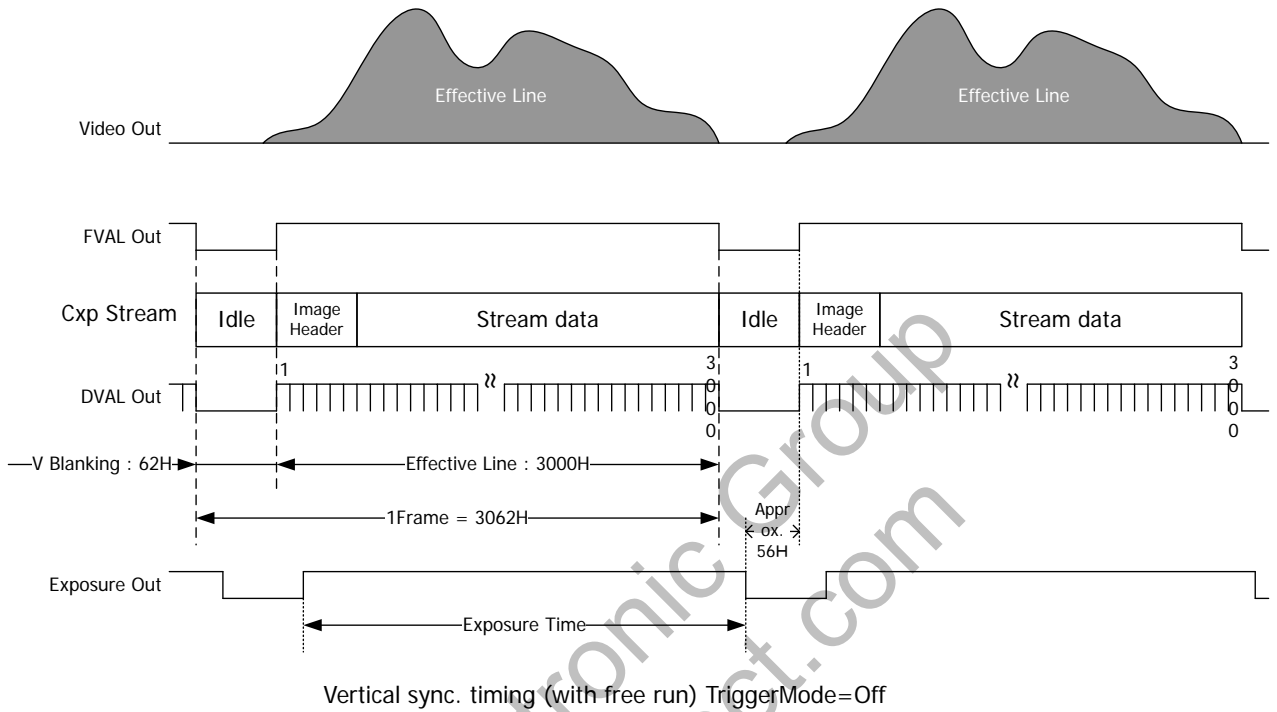

4.7. External Trigger Mode

- This is a mode to input external trigger signals to capture images by any preferred timings.

Acquisition Control	
TriggerMode	Off/On
TriggerSelector	AcquisitionStart FrameStart
TriggerSyncMode	LineSync ClockSync
TriggerSource	Link Trigger0 Line0 Software
TriggerSoftware	Execute
TriggerActivation	RisingEdge FallingEdge LevelHigh LevelLow

- TriggerMode (Link with TriggerSelector)
  - Off : Free run mode (TriggerSelector = AcquisitionStart)
  - On : External trigger mode (TriggerSelector = FrameStart)
    - ※ Do not change TriggerMode while grabbing (acquiring) images.
  
- TriggerSelector (Link with TriggerSelector)
  - AcquisitionStart : Free run mode (TriggerMode = Off)
  - FrameStart : External trigger mode (TriggerMode = On)
    - ※ Do not change TriggerSelector while grabbing (acquiring) images.
  
- TriggerSyncMode (Do not switch TriggerSyncMode while inputting triggers.)
  - LineSync : H sync. trigger mode (Control exposure time per line)
    - Fixed/Pulse width trigger shutter mode
    - ※ Overlapping operation (exposure while readout images) is valid.
  
  - ClockSync : CLK sync. trigger mode (Control exposure time per sensor clock)
    - FAST fixed/FAST pulse width trigger shutter mode
    - ※ Overlapping operation (exposure while readout images) is invalid.
    - ※ Set free run mode (internal sync) after set to LineSync mode.
  
- TriggerSource (Select where to input external triggers)
  - LinkTrigger0 : External trigger input from CoaXPRESS host device.
    - Please refer to specification manuals of the host device such as frame grabber board to know how to generate triggers.
  - Line0 : External trigger input from 6pins circular connector.
  - Software : TriggerSoftware
    - ※ Set TriggerMode On first, and set to either settings.
  
- TriggerSoftware : Software trigger
  - Camera generates a trigger to capture one frame image by executing this command.
  - Software Trigger is valid when TriggerSource is Software.
  
- TriggerActivation
  - This is to select how to start capturing video or its polarity out of the followings.
  - RisingEdge : Fixed trigger shutter mode : Rising edge (Timeed)
  - FallingEdge : Fixed trigger shutter mode : Falling edge (Timeed)
  - LevelHigh : Pulse width trigger shutter mode : High active (TriggreWidth)
  - LevelLow : Pulse width trigger shutter mode : Low active (TriggreWidth)
  - ※ When set FallingEdge and LevelLow with LinkTrigger0, disturbance images may occur when start grabbing for the first time after setting.

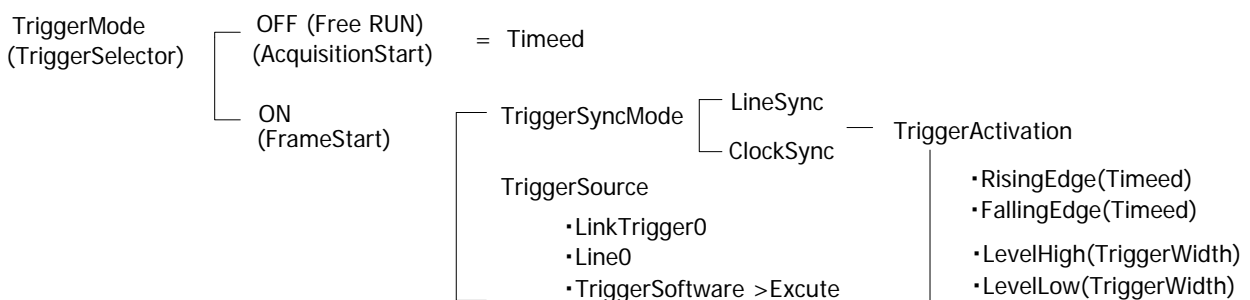

4.8. Trigger Sync Mode and Delay Time to Start Exposure

- H sync. trigger mode (LineSync):

1H of jitter may occur from inputting trigger to exposure. (Overlapping operation is valid.)

- CLK sync. trigger mode (ClockSync):

Less delay time from trigger input, and the precise trigger operation is valid. (Overlapping operation is invalid.)

Delay time to start exposure	CXP6_X2	CXP6_X1	CXP3_X2	CXP3_X1
With H sync. trigger (LineSync)	Approx. 2H~3H	Approx. 2H~3H	Approx. 2H~3H	Approx. 2H~3H
With CLK sync. trigger (ClockSync)	Approx. 0.05us	Approx. 0.05us	Approx. 0.05us	Approx. 0.05us

4.9. Restrictions on Trigger Pulse Input Timing

- User can input a trigger for the next frame while camera is reading out signals. However, do not input a trigger pulse to end exposure while camera is reading out signals. In other words, a trigger pulse to start reading out signals for the next frame before completion of reading out signals for the prior frame is restricted.

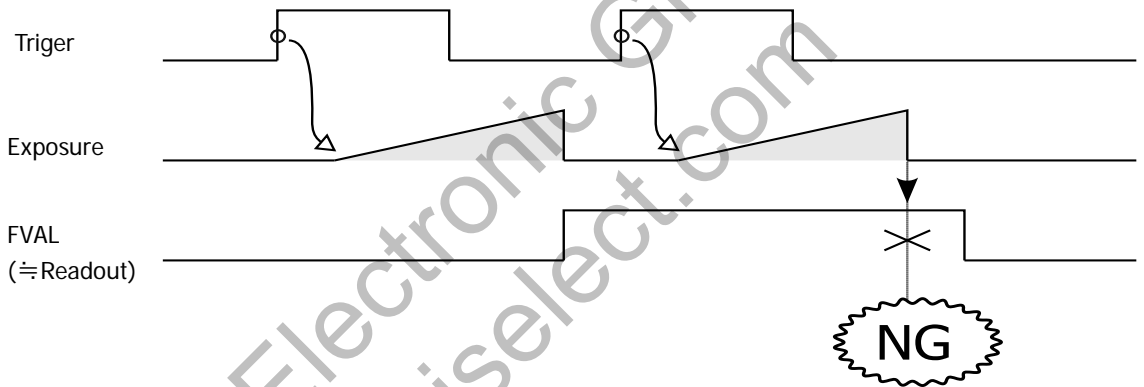

- If there is a trigger input with restricted timing explained in the above, "IllegalTriggerFlag" becomes "1".

Acquisition Control	
IllegalTriggerFlag	0 or 1

Since overlapping operation CLK is invalid with sync. trigger mode, trigger at this timing will be masked and "IllegalTriggerFlag" will not become "1".

Device Control	
ErrorFlagReset	Execute

This is to reset IllegalTriggerFlag to "0".

4.10. Fixed Trigger Shutter Mode (LineSync) H Sync. Trigger

( TriggerMode=On, TriggerSyncMode=LineSync, TriggerActivation=RisingEdge )

- This is a mode to start exposure with external trigger input and expose for a set period.
- Trigger operation is H sync., V-sync reset.

The delay time (Exposure Time Delay) from detecting trigger edge in the camera to starting ExposureActive is 2H~3H. 1H jitter will occur to exposure time delay since external trigger signal synchronizes with H inside the camera. Trigger pulse width to input must be longer than 1H. (Please refer to the time for 1 line for each mode in the following table.)

Camera mode	Time for 1 line
CXP-6 2 lanes	5.05μs
CXP-6 1 lane	10.10μs
CXP-3 2 lanes	10.10μs
CXP-3 1 lane	20.20μs

- There is an exposure time period for approx. **14.26μs** at the edge right after ExposureActive.



- User can input a trigger while camera is outputting images. However, do not input a trigger signal to start outputting next images before completion of outputting the prior images.

- Trigger input while exposure period (Exposure Time) will be ignored in the camera. ((A) in the drawing below)

Do not use a trigger shorter than 1 frame cycle.

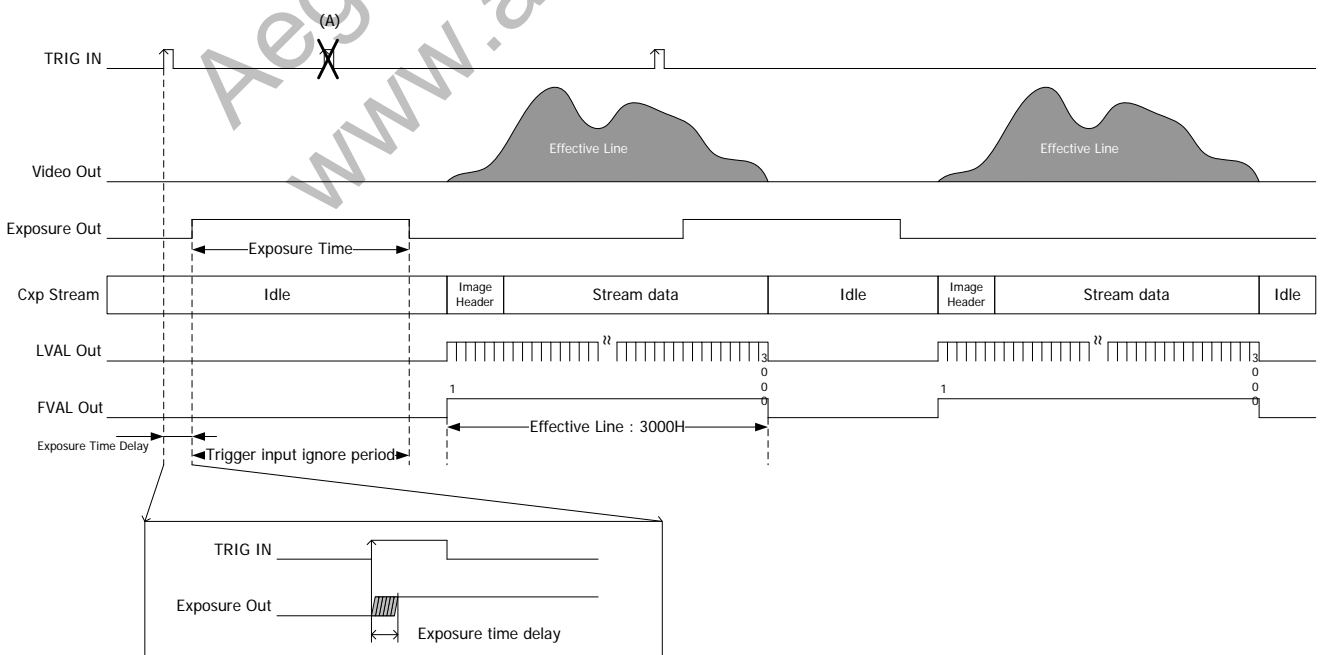

4.11. FAST Fixed Trigger Shutter Mode (ClockSync) CLK Sync. Trigger

( TriggerMode=On, TriggerSyncMode=ClockSync, TriggerActivation=RisingEdge )

- This is a mode to start exposure with external trigger input and expose for a set period.
- Trigger operation is CLK sync., V-sync reset.  
The delay time (Exposure Time Delay) from detecting trigger edge in the camera to starting ExposureActive is approx. 0.05 $\mu$ s. Trigger pulse width to input must be longer than 1 $\mu$ s.
- There is an exposure time period for approx. **14.26 $\mu$ s** at the edge right after ExposureActive.

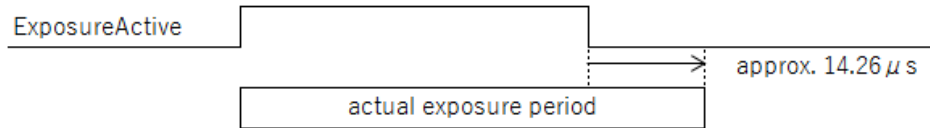

- The next trigger input while outputting images cannot be accepted.
- Trigger input while exposure period (Exposure Time) and readout period will be ignored in the camera. ((A) and (B) in the drawing below)

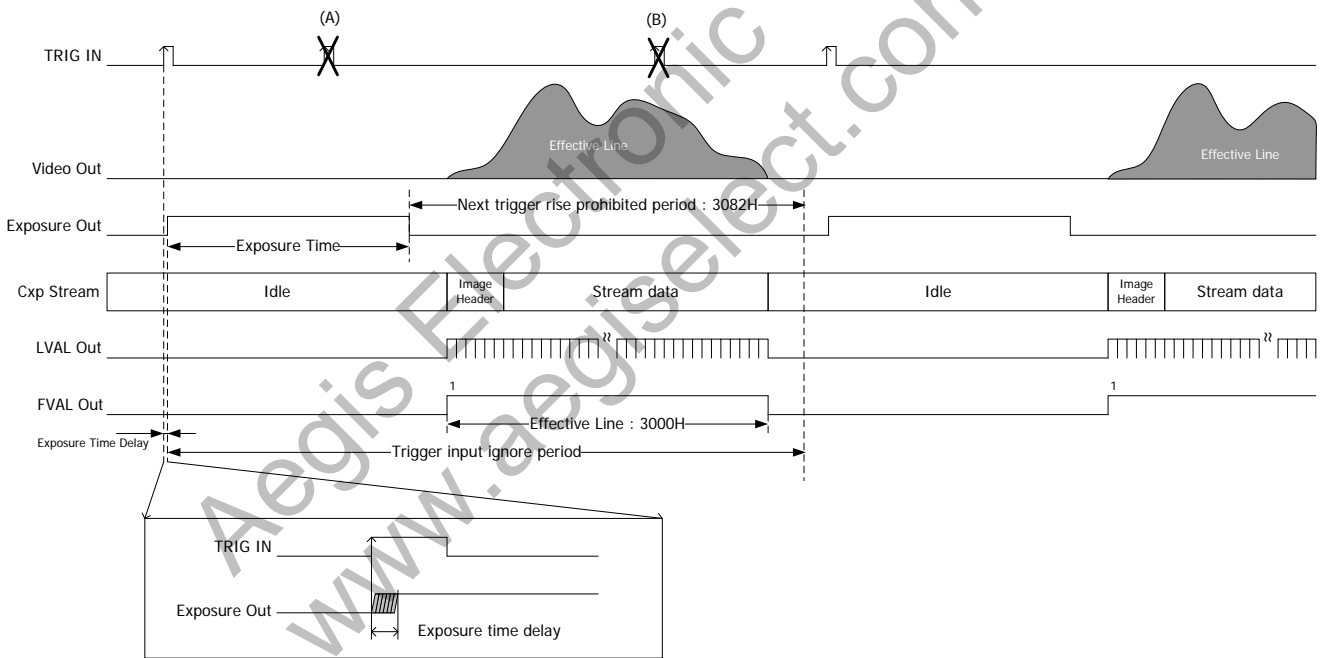

4.12. Pulse Width Trigger Shutter Mode (LineSync) H Sync. Trigger  
( TriggerMode=On, TriggerSyncMode=LineSync, TriggerActivation=LevelHigh )

- This is a mode to start exposure with external trigger input and set exposure time with pulse width of trigger signals.
- Trigger operation is H sync., V-sync reset.

The delay time (Exposure Time Delay①) from detecting trigger edge in the camera to starting ExposureActive is 2H~3H.

- Trigger operation is H sync., V-sync reset.

The delay time (Exposure Time Delay②) from detecting the trigger edge in the camera to end ExposureActive is 2H~3H.

- Approx. 1H jitter will occur to Exposure Time Delay ① and ② since external trigger signal synchronizes with H inside the camera. Jitters may occur at both start and end edges of exposure with pulse width trigger shutter mode. At this time, exposure time will change so that flicker may be shown in the image, especially when high speed shutter is set. This flicker sometimes can be eliminated with fixed trigger shutter mode. However, this problem can be solved by inputting trigger pulse with synchronizing it to the camera H cycle (LVAL).

- Pulse width 1H (Min.) ~ Approx. 2 frames

Functionally, there is no upper limitation, but noises such as dark noise shadings may be noticeable at long time exposure.

- There is an exposure time period for approx. **14.26μs** at the edge right after ExposureActive.



- Trigger input while exposure period (Exposure Time) will be ignored in the camera. Do not use a trigger shorter than 1 frame cycle.
- User can input a trigger while camera is outputting images. However, do not input a trigger signal to start outputting next images before completion of outputting the prior images. ((A) of TRIG IN in the drawing in the next page)

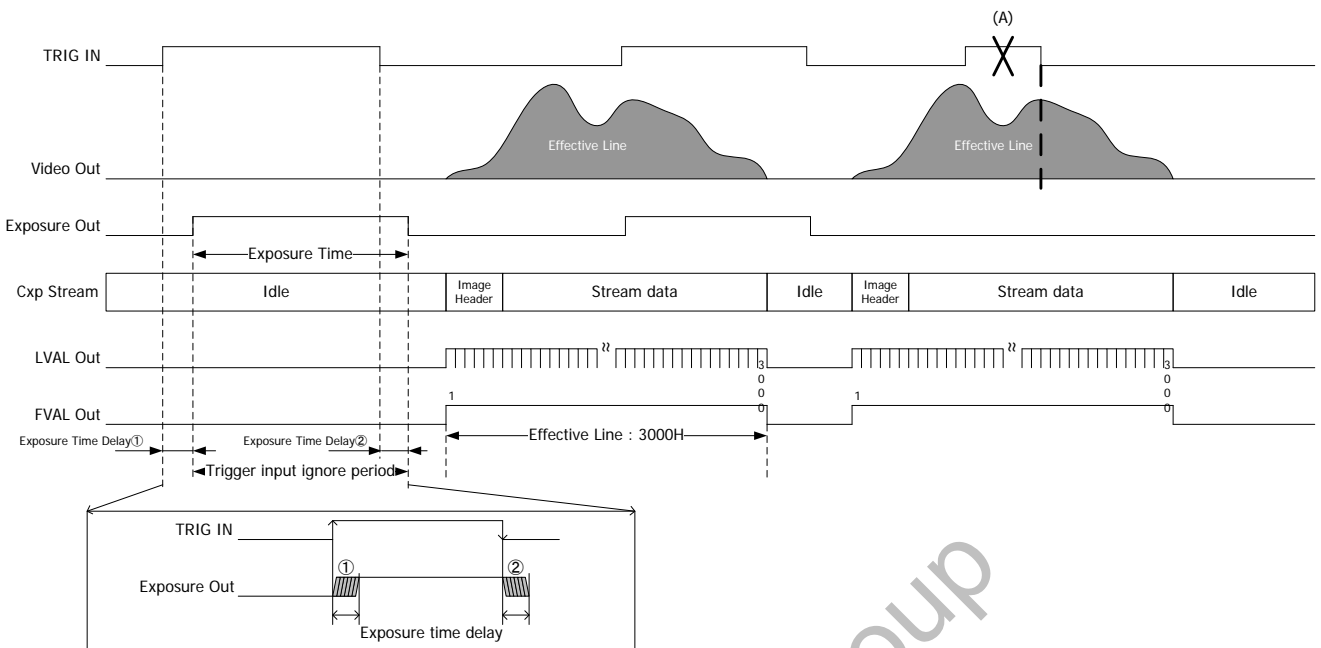

4.13. FAST Pulse Width Trigger Shutter Mode (ClockSync) CLK Sync. Trigger

( TriggerMode=On, TriggerSyncMode=ClockSync, TriggerActivation=LevelHigh )

- This is a mode to start exposure with external trigger input and set exposure time with pulse width of trigger signals.
- Trigger operation is CLK sync., V-sync reset.

The delay time (Exposure Time Delay①) from detecting trigger edge in the camera to starting ExposureActive is approx. 0.05μs.

The delay time (Exposure Time Delay②) from detecting trigger edge in the camera to end ExposureActive is approx. 0.05μs.

- Pulse width **0.74μs** (Min.) ~ Approx. 2 frames

Functionally, there is no upper limitation, but noises such as dark noise shadings may be noticeable at long time exposure.

- There is an exposure time period for **approx. 2.46μs** at the edge right after ExposureActive.

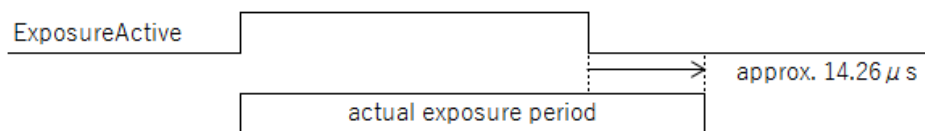

- Trigger input while readout period will be ignored in the camera. ((A) in the drawing in the next page.)

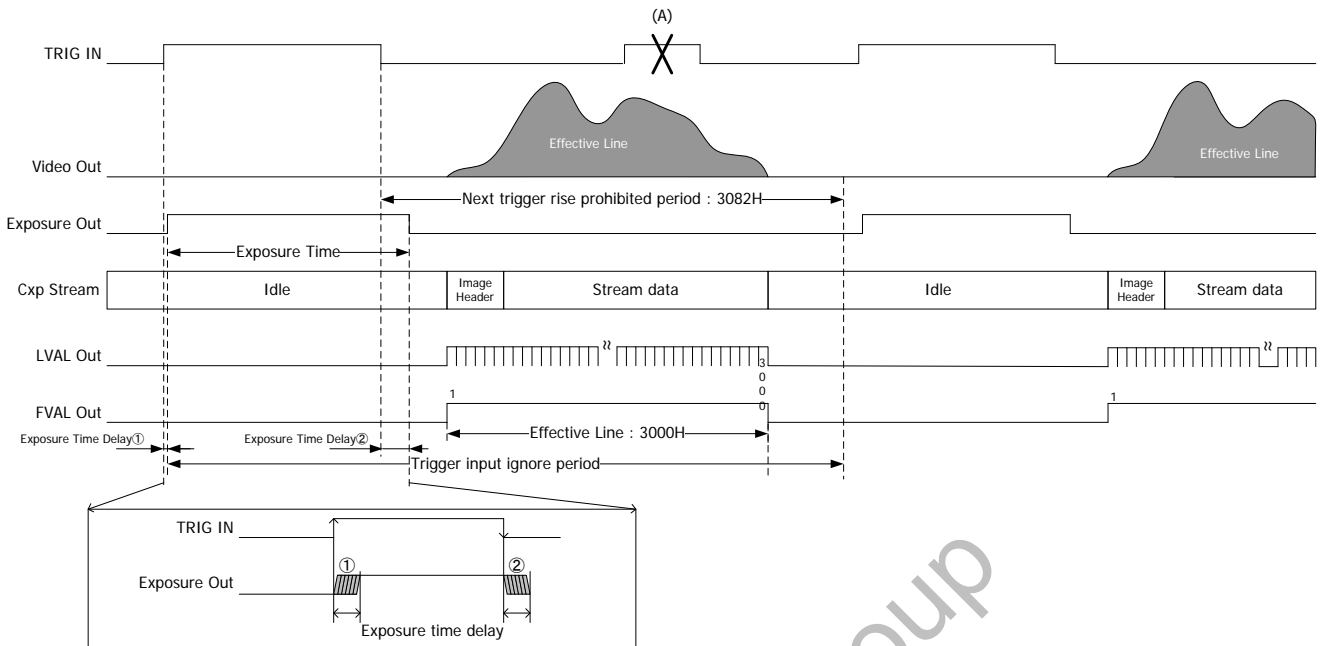

4.14. Exposure Time

Acquisition Control	
ExposureMode	Timed TriggerWidth
ExposureTime (us)	15us ~ Max. exposure time
ExposureTimeMax	(ReadOnly)

ExposureMode : This is to check if current mode is Timed or TriggerWidth (PWC).

ExposureTime : Exposure time (Valid when ExposureMode is Timed.)

- Set per 1H when the trigger operation is H sync. It will return the value (us) rounded by 1H per Min. 1H mode.
- Set per approx. 1us when the trigger operation is CLK sync.

ExposureTimeMax : Max. exposure time

- Set the smaller value than ExposureTimeMax when the camera is internal sync mode.  
It will depend on partial scan (ROI) settings, PixelFormat, and link rate.
- H sync. trigger mode (LineSync) will be clipped with effective line count.  
The maximum is 3000H. (Set line count is the maximum with partial scan.)
- CLK sync. trigger mode (ClockSync) can be set in the range of 15us~200ms.  
It will not be clipped with effective line count.

4.15. Formula to Calculate Manual Shutter Values with H Sync. Mode

The value will be corrected to the value corresponds to the following formula.

Formula: Exposure time = Time for 1 line (Please refer to the table below) × Exposure line count + 14.26μs

Camera mode	Time for 1 line
CXP-6 2 lanes	5.05μs
CXP-6 1 lane	10.10μs
CXP-3 2 lanes	10.10μs
CXP-3 1 lane	20.20μs

※ The Min. setting value will be clipped with 1, and the Max. value will be clipped with 3000 or with the total line count of partial mode.

## 4.16. Manual Shutter Settings with CLK Sync. Mode (FAST Trigger Mode)

- Min. setting value: **15 $\mu$ s (Approximate value)**
- Max. setting value: **200ms (Approximate value)**
  - ※ Unlike H sync. mode, exposure time will not be clipped with total line count, etc.
  - ※ Bright point may be noticeable with long time exposure.
- Setting unit: 1 $\mu$ s (Approximate value)
  - ※ Slight differences may occur since it is generated by 74.25MHz.

## 4.17. Gain

AnalogControl	
Gain	Manual

User can set gain value in the range of x1.00~x256.00.

Functionally, up to x256.00 can be set. However, with x64.00 or higher gain, noise will increase and image quality deteriorates.

## 4.18. Gamma Correction

AnalogControl	
Gamma	0.10~1.80

Gamma : This is to set gamma correction value per 0.01 step.

[Note]

Camera updates gamma table at the timing of image output.

With continuous operation mode, camera applies the updated gamma table at the timing of image output after completion of rewriting gamma table (approx. 20ms: refer to Command ACK as a rough guide).

If user changes gamma coefficient while waiting for a trigger input, camera outputs images with updated gamma table with a trigger after completion of rewriting gamma table.

## 4.19. Black Level Adjustment

- This is to adjust black level of image sensor.

AnalogControl	
BlackOffset	0~100

[Note]

This is not a function to set absolute value of black level.

Black level of image sensor can be change proportionally.

※ Make sure to stop grabbing (acquiring images) when change settings.

## 4.20. Partial Scan (ROI)

- This is to increase frame rate by cutting and reducing read out area.
- Partial scan cannot be used with 2x2 binning mode.
- It will be Idle output when RegionMode of Region 1~8 are all OFF.

ImageFormatControl	
RegionSelector	EffectiveRegion , Region1~8
RegionMode	On/Off
RegionDestination	Stream0
Width	4096 (Fixed)
Height	4~3000 (Multiples of 4)
OffsetX	0 (Fixed)
OffsetY	0~2996 (Multiples of 4)

- RegionSelector: This is to select Region to set.
  - User can set 8 partial areas with Region 1~8. Select EffectiveRegion to check Width and Height of the effective partial area.
  - ※ Make sure to set RegionSelector to EffectiveRegion to start capturing images.
  - ※ Make sure to select EffectiveRegion when the camera is set to 2x2 binning mode.
  - ※ Make sure to select EffectiveRegion when the SourceSelector is set to StillView.
- RegionMode: On/Off of the Region1~8. User can check if there is an effective region with EffectiveRegion.
  - ※ Enabled only when Width, Height, OffsetX, and OffsetY are effective.
  - ※ Make sure to turn off shading correction to change RegionMode.
- RegionDestination: Selection of Stream to output. Fixed with Stream0.
- Width : Width of Region. This model VCC-12CXP4M is fixed to 4096.
- Height : Height of Region.
- OffsetX : Offset for X direction of Region. This model VCC-12CXP4M is fixed to 0.
- OffsetY : Offset for Y direction of Region.
  - ※ Make sure that OffsetY and Height do not overlap with other regions.

- Maximum 8 areas can be set as vertical partial area.

In case of setting 3 partial areas:

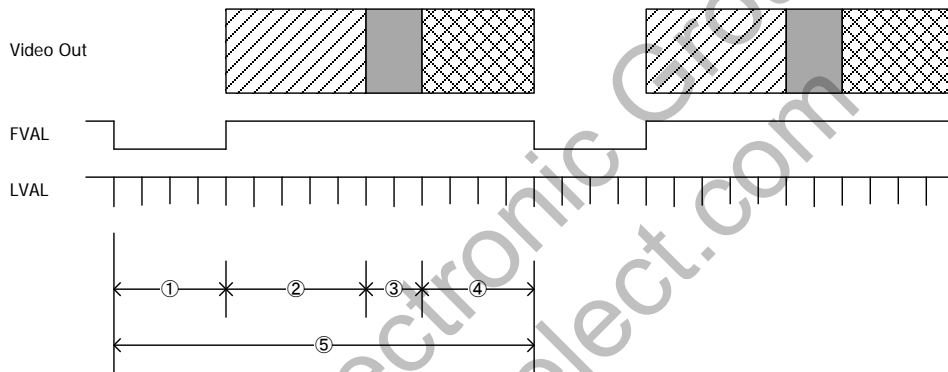
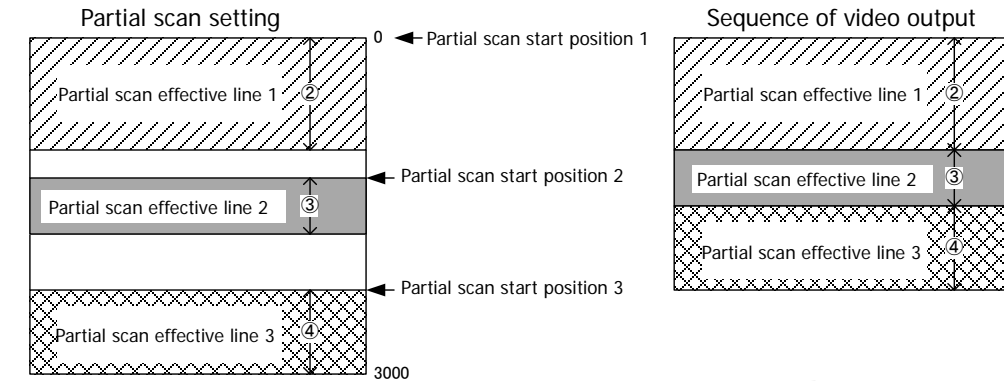

- ① : V blanking line
- ② : Partial area 1
- ③ : Partial area 2
- ④ : Partial area 3
- ⑤ : Total line count per frame

When setting several partial scan areas, make sure that start positions and effective lines do not overlap each area.

- Total line count per frame = V blanking line count + Partial effective line 1 + Partial effective line 2 + ... + Partial effective line 8

However, make sure that sum total of partial effective line numbers from 1~8 (except V blanking lines) is less than 3000.

V blanking line count is 62H with partial mode.

- Frame rate = 1 / (Total line count per frame × Time for 1 line)

Time for 1 line

Camera mode	Time for 1 line
CXP-6 2 lanes	5.05μs
CXP-6 1 lane	10.10μs
CXP-3 2 lanes	10.10μs
CXP-3 1 lane	20.20μs

## Setting examples

	Number of active lines	Frame rate (total number of lines of frame)											
		CXP6 X2				CXP6 X1, CXP3 X2				CXP3 X1			
4 (minimum)	4	3000.3	fps	66	(H)	1500.2	fps	66	(H)	750.1	fps	66	(H)
Equivalent to vertical VGA	480	365.4	fps	542	(H)	182.7	fps	542	(H)	91.3	fps	542	(H)
Equivalent to vertical XGA	768	238.6	fps	830	(H)	119.3	fps	830	(H)	59.6	fps	830	(H)
Equivalent to vertical SXGA	1024	182.3	fps	1086	(H)	91.2	fps	1086	(H)	45.6	fps	1086	(H)
Equivalent to vertical UXGA	1200	156.9	fps	1262	(H)	78.5	fps	1262	(H)	39.2	fps	1262	(H)
3000 (maximum)	3000	64.7	fps	3062	(H)	32.3	fps	3062	(H)	16.2	fps	3062	(H)

- The line numbers with partial scan setting can be set from 4 lines. Only multiple numbers of 4 can be set.
- With partial scan, the effective line count of manual shutter setting becomes the maximum value (except at ClkSync trigger).
- When switch between Full frame scan mode and Partial scan mode, or changing partial settings, 1 frame after the change will be invalid.  
Especially with fixed trigger shutter mode and pulse width trigger shutter mode, input a dummy trigger for 8 times, then use from 9<sup>th</sup> trigger as actual video signals.

## 4.21. 2×2 Binning Mode

ImageFormatControl	
BinningHorizontalMode	Sum
BinningHorizontal	1~2
BinningVerticalMode	Sum
BinningVertical	1~2

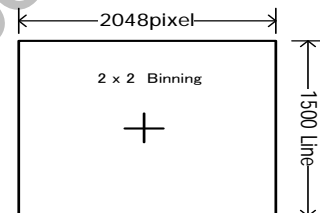

- Horizontal setting and Vertical setting mutually link. If user changes either horizontal setting or vertical setting to 2, 2x2 binning mode will be set.  
 ※Please turn OFF DefectPixelCorrection to set 2×2 Binning mode. Please note that defective pixel correction is not effective with this mode.  
 ※Please set RegionSelector to EffectiveRegion to change BinningHorizontal and BinningVertical.
- 4 pixels of horizontal and vertical will be mixed and output as 1 pixel. The sensitivity will be approx. 4 times higher. This is fixed to simple addition (Sum).
- Since the vertical line will be 1/2, frame rate can be increased while maintaining the field angle at full resolution.
- This mode cannot be used with partial scan (ROI) function at the same time.

Frame rate of Binning mode [fps]

2x2 Binning mode (Number of pixels)	PixelFormat	Link rate (fps)			
		CXP6_X2	CXP6_X1	CXP3_X2	CXP3_X1
(2048x1500)	mono8	127.1	63.5	63.5	31.8
	mono10	127.1	63.5	63.5	31.8

#### 4.22. Shading Correction

- This is to correct the drop in the amount of peripheral light caused by lens and others.

AnalogControl	
ShadingCorrectionDataSelector	Off/Table1/Table2/Table3
DetectShading	Execute

ShadingCorrectionDataSelector:

Select shading correction ON/OFF, shading correction table to use, or where to save shading detection data.

Select Off to disable shading correction.

When selecting Table1 - Table3, correction function will be ON according to each correction value.

Correction data can be acquired to the Table by executing DetectShading while selecting Table1- Table3.

※Please note that ShadingCorrectionDataSelector cannot be executed when setting several partial scan areas.

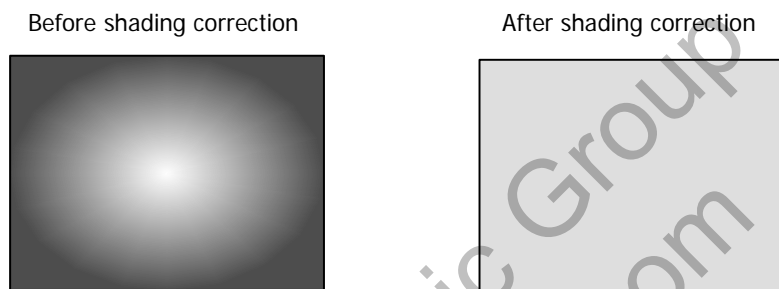

DetectShading: Shoot an object with stable brightness such as pattern box to full screen to execute DetectShading. Function automatically calculates shading correction data of the table selected with ShadingCorrectionDataSelector.

[Note]

- Make sure to turn OFF vertical partial mode and binning to detect shading. (Execute with the size of 4096x3000.)
- Execute shading detection again when switch ReverseY.
- Acquire correction data when camera is in operation. (Acquisition of shading correction data is invalid when there is no output from camera).
- When executing UserSetSave, Correction data of Table1~Table3 will be saved in the camera non-volatile memory at the same time.
- Camera will maintain correction data even executed Default with UserSetLoad.
- When obtain correction data with trigger shutter mode, the data sometimes becomes unstable. In this case, change the trigger cycle in small measure and obtain correction data again.

#### 4.23. Defective Pixel Correction

- This is a function to detect and correct defective pixels in output data from the sensor.
- There are two types of defective pixel data.
  - Defective data registered at factory  
Black and white defective pixel data registered upon shipment from our factory. These data cannot be over-written.
  - Defective data registered by user  
Data registered by user. In addition to the correction of defective pixel data registered upon shipment, we provide a method to update the defective pixel data. With DefectPixelDefault command, user can delete these user-registered data.

- With normal operation and H&V flipping, defective pixel correction information are saved separately.  
(The position and the number of defective pixels are different with normal operation and H&V flipping)
- User can register up to 256 points. (Note: Up to 32 points per CH.)

[CH (Channel)]

Camera performs image processing with 8CH interleave.

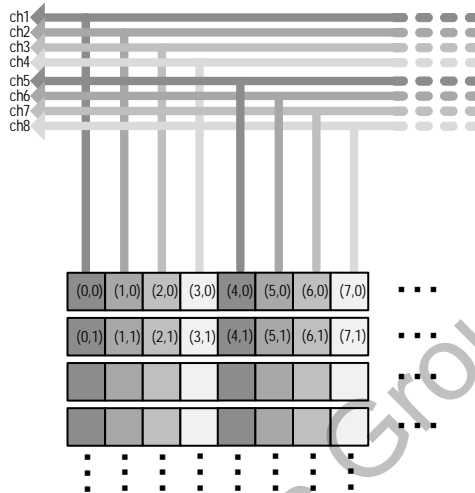

- Defective pixel correction control:  
This is to turn ON/Off defective pixel correction processing.  
Defective pixel data corrected at factory and defective pixel data corrected by user are controlled at the same time.
- Defective data registered by user: Designate coordinate X and Y  
This is to designate coordinates to register and delete the preferred pixels as defective pixels.



※ With B/W model

Defective pixel correction function calculates value for X pixel referring to peripheral pixels (up and down, left and right).

When all peripheral pixels, X1, X2, X3, and X4, are already registered as defective pixels, user cannot correct the X pixel.

AnalogControl	
DefectPixelCorrection	On/Off
DefectPixelAdd	(Execute)
DefectPixelAddOffsetY	0~2999
DefectPixelAddOffsetX	0~4095
DefectPixelDelete	(Execute)

- DefectPixelCorrection: Enable or disable defective pixel correction function.
- DefectPixelAddOffsetY: Designate Y coordinate.
- DefectPixelAddOffsetX: Designate X coordinate.
- Execute DefectPixelAdd to register the designated coordinates as defective pixels.
- Execute DefectPixelDelete to delete the designated coordinates from registered defective pixels.

- ◇ Make sure to turn off binning to execute defective pixel correction.
- ◇ When user designate the same coordinates as those registered at factory, function ignores them.
- ◇ Only the defects added by "Defective pixel detection registered by user" or "Defective pixel added by user" can be deleted.
- ◇ Data registered at factory is not subject to delete with DefectPixeDelete command.

□ Defective pixel detection registered by user

This is for user to detect and register correction data of white defect caused by image sensor.

<b>AnalogControl</b>	
DefectDetectionThesholdValue	0~1023
DefectDetection	(Execute)
DefectDetectionStatus	(ReadOnly)
DefectPixelDefault	(Execute)
DefectCorrectMode	Reacquire/Add

- DefectDetectionThesholdValue: This is to set a threshold value (0~1023: 10bit equivalent) for user defective pixel detection. Data which exceeds the luminance level designated here will be registered. With 8bit images, designate a value of 4 times of signal level as a threshold value.
- DefectDetection: This is to detect defective pixels registered by user. Function automatically registers pixels that exceed the level designated with DesignefectDetectionThresholdValue. Make sure to shield light from image sensor to execute. Function reflects defective pixel correction registered by user immediately after execution. Execute UserSetSave after DefectDetection to save data into non-volatile memory.
- DefectDetectionStatus: This is to indicate results of defective pixel detection proceeded by user.

0	No defective pixel correction data registered by user.
Value (256 or less)	Number of detected defective pixels registered by user.
0x000e0001 (917505)	Total number of defective pixel correction data exceeds the maximum number to register in one CH. (32)
0x000e0002 (917506)	Total number of defective pixel correction data exceeds the maximum number to register. (256 points) ※Error may indicate in decimal according to frame grabber board to use.

When the value 256 or more is indicated, check if user threshold value (DefectDetectionThresholdValue) and the indication of defective pixels are appropriate. Also, reacquire DefectCorrectMode or execute DefectPixelDelete and check if the light is shielded. Then, change the detect condition (gain and threshold value) and execute it again.

- DefectPixelDefault: This is to delete entire defective pixel correction data registered by user.
- DefectCorrectMode: Set detection mode of defective pixels.
  - Reacquire mode: This mode deletes defective pixel data except those added by one point addition and reacquire defective pixels.
  - Add mode: This mode acquires defective pixels in addition to the current pixels registered.

## [Note]

- Make sure to acquire defective pixel correction data when camera is in operation.
  - Make sure to turn OFF partial scan, shading, or binning mode to detect defective pixels. (Region number of ROI needs to be 4096×3000).
  - To acquire user defective pixel correction data by changing threshold value of DefectDetectionThresholdValue, execute DefectPixelDefault first to delete defective pixel correction data registered by user and reacquire it.
  - Maximum number of defective pixels to register and to correct may not always be the same due to following reasons.
- (1) With white defects detection, if one of interleave channel reaches the maximum number of defective pixels to register, correction stops. Function registers data up to that point, outputs error, and ends operation.
- (2) When there is no effective pixel around the pixel to add (on the left, right, top, and bottom), user can register but cannot correct that pixel.

 Indication of defective pixel coordinates

This is to indicate the coordinates of defective pixels registered by user.

AnalogControl	
RegisteredDefectSelector	UserState/InitialState
DefectPixelNumber	1~256/1~768
DefectPixelOffsetY	(ReadOnly)
DefectPixelOffsetX	(ReadOnly)
DefectPixelType	(ReadOnly)

- RegisteredDefectSelector : This is to select the types of registered defects.
- DefectPixelNumber : This is to set the registered number of defective pixels and designate a table number of the defective data registered at factory and by user.
- DefectPixelOffsetY : This is to indicate Y coordinate of the defective pixel designated with DefectPixelNumber. When user designated a table number with no defective pixel data, it shows 65535.
- DefectPixelOffsetX : This is to indicate X coordinate of the defective pixel designated with DefectPixelNumber. When user designated a table number with no defective pixel data, it shows 65535.
- DefectPixelType : This is to indicate the types of defects designated with DefectPixelNumber.
  - 1: White defects registered upon shipment from factory
  - 2: Black defects registered upon shipment from factory
  - 6: Defects registered by user
  - 7: Defects additionally registered by user
  - 65535: Table without defects

AnalogControl	
ChannelNumber	1~8
DefectPixelChannelCount	(ReadOnly)

- ChannelNumber : This is to designate channel number of defective pixel processing.
- DefectPixelChannelCount : Indicate the number of defective pixels designated with ChannelNumber.  
The number of defective pixel of the designated channel number is the sum total of defective pixel number upon shipment and the number of defective pixels registered by user.

## 4.24. Test Pattern Indication

- This is to output test pattern from camera. This is useful to check if your system is operating properly.

ImageFormatControl	
TestPattern	Off GrayHorizontalRamp (Monochrome model only)

※ Test pattern indication cannot be used when cursor is On.

## 4.25. Cursor Indication

- This is to indicate cursor on your display screen.

ImageFormatControl	
CursorPattern	Off
CursorOffsetX	X coordinate
CursorOffsetY	Y coordinate
CursorColor	White/Black

CursorPattern : Cursor indication On/Off. (Cursor indication cannot be used when test pattern is On.)

CursorOffsetX : Designate X coordinate of vertical cursor.

CursorOffsetY : Designate Y coordinate of horizontal cursor.

CursorColor : This is to select the color of cursor. (black or white)

## 4.26. LED Operational Mode

- This is to change operational mode of LED at the rear of the camera. For information on lighting patterns, please refer to [Section 3.3.3. LED Indicator](#).

DeviceControl	
DeviceIndicatorMode	Active ErrorStatus Inactive

Active : Indication of communication status of CoaXPress.

ErrorStatus : OFF with normal operation. Lights only with system error.

Inactive : ALL LED OFF.

## 4.27. Camera Timing Output

- According to LineSource settings, camera outputs the following signals through pin No. 3 of 6pins circular connector.

Digital IO Control	
LineSelector	Line0
LineMode	Output
LineSource	OFF ExposureActive FrameActive LineActive TriggerPacketActive

ExposureActive : This is to indicate exposure period of image sensor with Hi Active.

FrameActive : This is to indicate effective period of frame with Hi Active.

LineActive : This is to indicate effective period of video output line with Hi active.

TriggerPacketActive : This is to decode and output packet signals of uplink trigger from frame grabber.

## 4.28. User ID

DeviceControl	
DeviceUserID	Manual

- Set a letter string as DeviceUserID with up to 16 characters including NUL letter (\0). Execute UserSetSave to save these letter strings to camera non-volatile memory. These data will be kept even executing "UserSetLoad" with "Default."

## 4.29. Temperature Indication

- This is to indicate temperature of image sensor (°C)

DeviceControl	
DeviceTemperature	ReadOnly

[Note] This value is not calibrated. Please regard it as reference value.

Aegis Electronic Group  
www.aegiselect.com

## 5. Factory Settings

Function	Data	Descriptions
TriggerSelector	AcquisitionStart	Equivalent to TriggerMode=Off
TriggerMode	Off	Link with TriggerSelector.
TriggerSyncMode	LineSync	Horizontal sync mode
TriggerSource	LinkTrigger0	CXP UP link trigger
TriggerActivation	RisingEdge	Rising edge
ExposureTime	9999.0	≒10ms ( 1/100s )
Gain	1.00	x1.00
Gamma	1.00	Gamma coefficient=1.00
DefectPixelCorrection	On	Defective pixel correction On
DefectPixelAddOffsetX	0	X coordinate of defective pixel to correct
DefectPixelAddOffsetY	0	Y coordinate of defective pixel to correct
DefectDetectionThesholdValue	50	Threshold value of defective pixel detection
ShadingCorrectionDataSelector	Off	Shading correction table
BlackOffset	8	Black level initial value
PixelFormat	Mono8	Monochrome model
ConnectionConfig	CXP6_X2	CxpLinkConfiguration
TestMode	NomalOperation	Use with NomalOperation of Link test mode
RegionSelector	EffectiveRegion	Designate partial area (ROI) (Region1~8)
RegionMode	On	Partial area (ROI) operation On/Off
Height	3000	Designate height of partial area (ROI)
OffsetY	0	Designate start position of partial area (ROI)
ReverseX	FALSE	Horizontal flip OFF
ReverseY	FALSE	Vertical flip OFF
TestPattern	Off	Cannot use cursor indication at the same time.
CursorPattern	Off	Cannot use test pattern at the same time.
CursorOffsetX	2048	Position of cursor X
CursorOffsetY	1500	Position of cursor Y
CursorColor	White	Cursor color White/Black
BiningHorizontal	1	Monochrome model only
BiningVertical	1	Monochrome model only
DeviceIndicatorMode	Active	Display LED indicator
LineSource	Off	Circular 6P-3pin output setting
SourceSelector	Source0	Normal operation

※ ConnectionConfig and PixelFormat are not subject to UserSetLoad operation.

6. Dimensions

6.1. Camera Dimensions

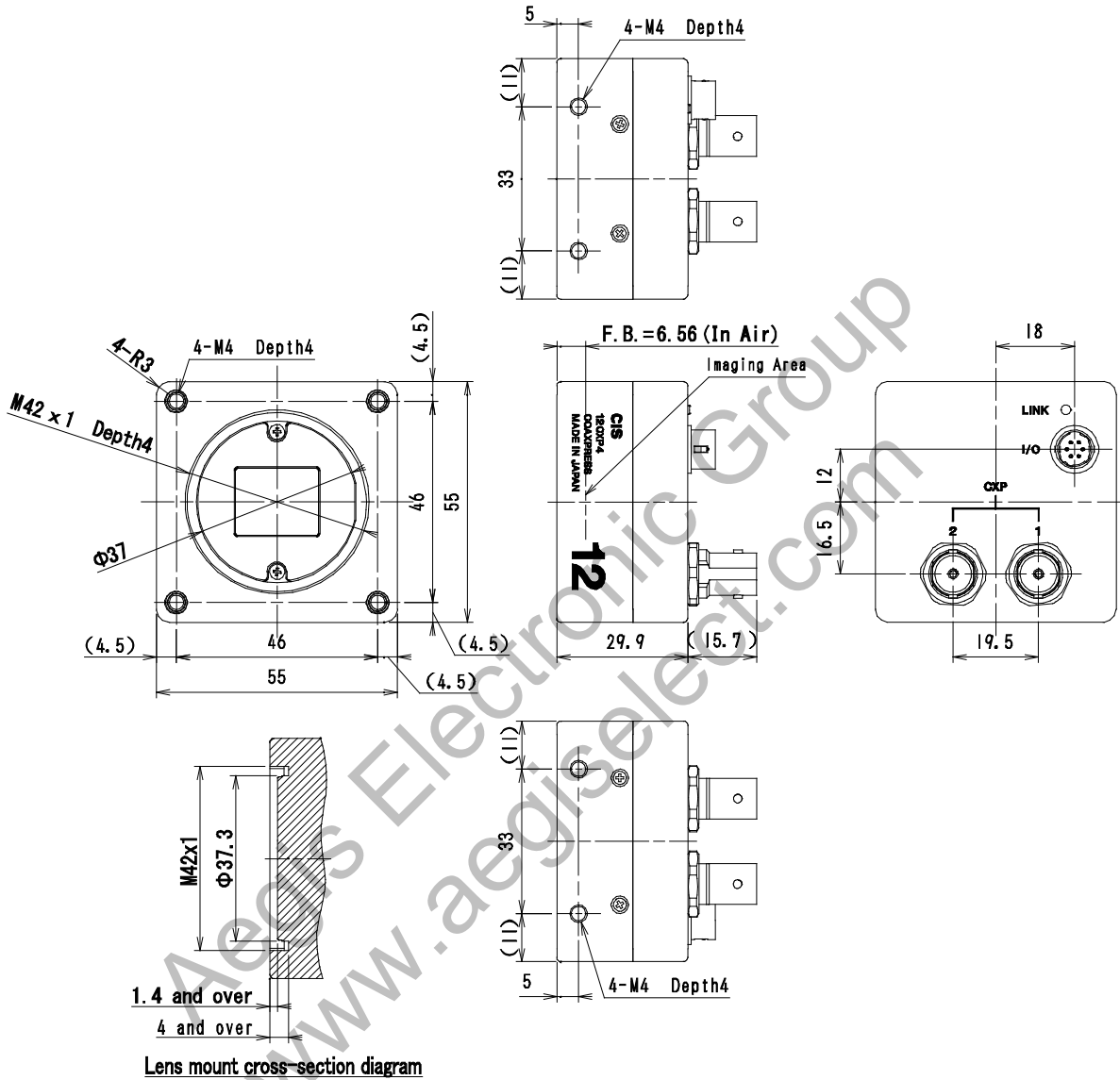

**Note 2)** Lens mount screw complies with M42x1.0-6H. Please refer to ISO 68-1,965-1 ( or JIS B0205-1,B0209-1).

**Note 1)** Please make sure the protrusion portion does not interfere with the lens selected. Refer to the Lens mount cross-section diagram for the details.

935-0130-00  
(Unit : mm)

6.2. Optical Axis Accuracy

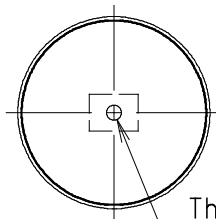
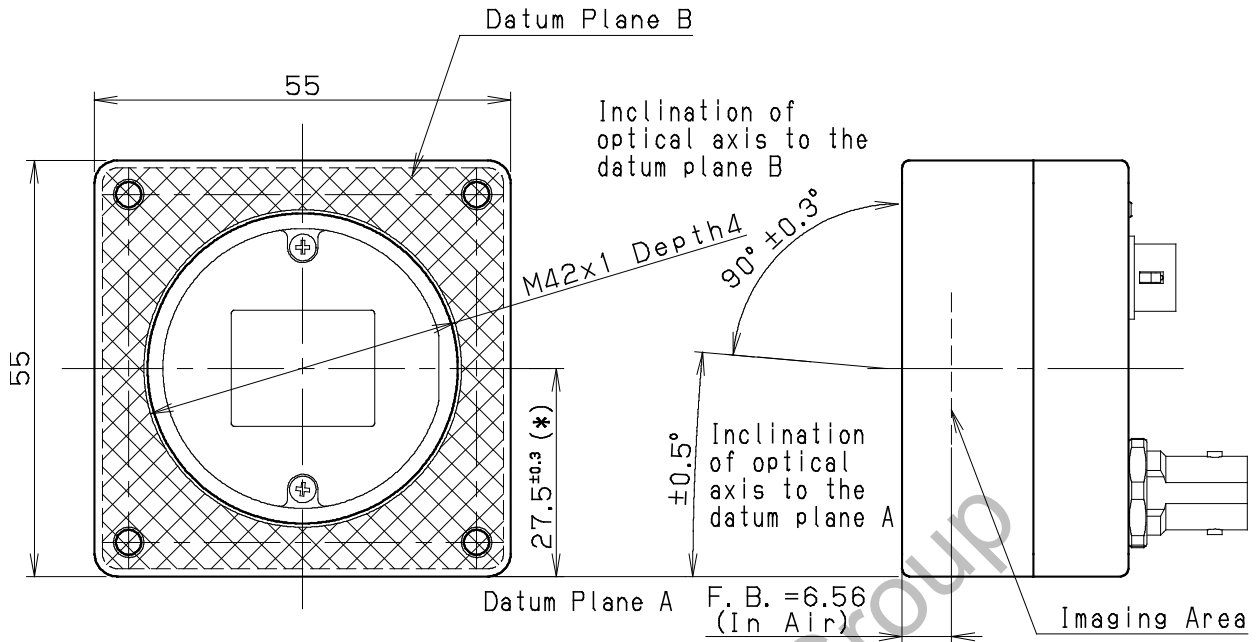

The center of the effective pixels shall be within 0.6 to the center of the lens mount.

Aegis Electronic Group  
www.aegisselect.com

Inclination of the effective pixels  $\theta$  to the datum plane is  $\theta \leq \pm 1^\circ$ .

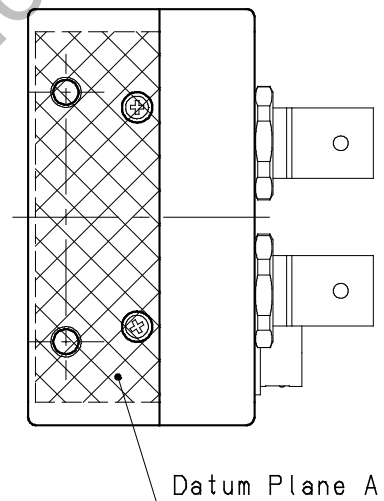

\*) Dimensions from the datum plane A to the center of the lens Mount

937-0024-00  
(Unit : mm)

## 7. Case for Indemnity (Limited Warranty)

### 7.1. Product Warranty

The term of warranty of this product is within 3 years from the date of shipping out from our factory.

If you use the product properly and discover a defect during the warranty period, and if that was caused by designing or manufacturing, CIS Corporation, at its option, repairs or replaces it at no charge to you. Products out of warranty period will be subject to charge.

CIS should not hold responsible for damages or losses if;

- damages or losses are caused by earthquake, lightning strike, fire, flood or other acts of God.
- damages or losses are caused by deliberate or accidental misuse by user, or failure to observe the information contained in the instructions in this Product Specification and Operational Manual.
- damages or losses are caused by repair or modification conducted by customer or any unauthorized party.

### 7.2. CMOS Defective Pixels

CIS applies defective pixel correction prior to the shipment of the product. However, the number of defective pixels are subject to increase due primarily to the effect of cosmic rays. Due to this nature, CIS should not hold responsible for the natural increase of defective pixels.

### 7.3. Product Support

Should you have any problems in function of the product you purchased, and if you need our further analysis and/or repair, please contact your local distributor.

Aegis Electronic Group  
www.aegiselect.com