

CIS

English

CoaXPress I/F
5.3M CMOS Near-Infrared Camera

VCC-5CXP3NIR

Product Specifications & Operational Manual

CIS Corporation

Table of Contents

	PAGE
1. Handling Precautions	3
2. Product Outline	3
3. Bundled Items.....	3
3.1. Standard Bundled Items	3
3.2. Packaging.....	3
4. Specifications	4
4.1 General Specifications	4
4.2 Camera Output Signal Specifications.....	5
4.3 Spectral Response.....	5
5. External Connector Pin Assignment	6
5.1 75Ω BNC Connector	6
5.2 6pins Circular Connector	6
6. How to Save and Initialize the Settings	7
7. Camera Operational Mode	7
7.1 Link Configuration	7
7.2 Pixel Format Settings.....	7
7.3 Camera Sync. Mode	8
7.3.1 Internal Sync. Mode (Free Run Mode)	8
7.3.2 External Trigger Sync. Mode	9
8. Camera Function Settings.....	12
8.1 Gain Settings	12
8.2 Exposure Time Settings.....	13
8.3 ROI (Region of Interest)	14
8.4 Sub-sampling.....	16
8.5 Image Sensor Defective Pixel Correction	16
8.6 Shading Correction.....	17
8.7 Black Offset	17
8.8 Test Pattern.....	18
8.9 LED Indicator	18
8.10 Camera Timing Output	19
8.11 DeviceUserID Setting	19
9. Sequence Control Function.....	20
9.1 Basic Operation for Sequence Control.....	21
9.2 Trigger Mode and Burst Mode Operational Outline	22
9.3 Trigger Mode	23
9.4 Burst Mode	24
9.5 Index Mode	25
9.6 Settings for Sequence Control	26
9.7 Sequence Status Output	28
10. Factory Settings.....	29
11. Dimensions	30
11.1 Optical Axis Accuracy.....	30
11.2 Camera Dimensions	31
12. Case for Indemnity (Limited Warranty)	32
13. Product Support	32

1. Handling Precautions

The camera module must not be used for any nuclear equipment or aerospace equipment with which mechanical failure or malfunction could result in serious bodily injury or loss of human life. Our warranty does not apply to damages or defects caused by irregular and/or abnormal use of the product. All specifications contained herein are subject to change without prior notice. Reproduction in whole or in part is prohibited.

Please observe all warnings and cautions stated below.

Our warranty does not apply to damages or malfunctions caused by neglecting these precautions.

- Do not use or store the camera module in the dusty or humid places.
- Do not apply excessive force, vibration, or static electricity that could damage the camera. Handle the camera with caution.
- Do not shoot direct images that are extremely bright (e.g., light source, sun, etc.). When extremely strong light source is shot, smear or blooming may occur. When the camera is not in use, please put the protection cap on.
- Follow the instructions in Chapter 5, "External Connector Pin Assignment" for connecting the camera module. Improper connection may cause damages not only to the camera module but also to the connected devices.
- Confirm the mutual ground potential carefully and then connect the camera module to monitors or computers. AC leaks from the connected devices may cause damages or destroy the camera module.
- Do not apply excessive voltage. (Use only the specified voltage.) Unstable or improper power supply voltage may cause damages or malfunction of the camera assembly.
- Do not disassemble the camera. The camera once disassembled shall be out of warranty.

2. Product Outline

VCC-5CXP3NIR is a CoaXPress interfaced small NIR camera utilizing a 1-inch type, 5.3M pixels CMOS image sensor.

Features

- 29mm x 29mm x 55mm in size
- Global shutter type CMOS (Near Infrared)
- High sensitivity in near infrared wavelength region
- CoaXPress CXP-1/2/3/5/6 x 1 each
- The maximum frame rate: 85.1 fps (at CXP6, full resolution)
- The maximum cable length: Approx. 100m (at CXP-1)
- ROI
- Sub-sampling
- Exposure, Gain settings
- External trigger mode (Fixed trigger shutter mode / Pulse width trigger shutter mode)
- Sequence control function
- Shading correction
- GenICam complied

3. Bundled Items

3.1. Standard Bundled Items

- Camera module, VCC-5CXP3NIR
- Lens cap

3.2. Packaging

- Individual carton
- Master carton (10pcs/carton)

Note) Q'ty per master carton may vary depends on the shipping q'ty.

4. Specifications

4.1 General Specifications

(1) Image sensor	Device type	1-inch type Global shutter CMOS	
	Effective pixel numbers	2592(H) × 2048(V)	
	Unit cell size	4.8μm(H) × 4.8μm(V)	
(2) Video output frequency	Pixel clock	72MHz	
(3) CoaXPress	Ver. 1.0 complied. CXP1/2/3/5/6 x1 each		
(4) Video output format	MONO8 /MONO10		
(5) Resolution	2048 TV lines		
(6) Output (Sensor AD)	10bit		
(7) Sensitivity	F4 400lx (Shutter 1/300(s), Gain 0dB)		
(8) Minimum illumination	F1.4 3.6lx (Shutter 1/300(s), Gain 18dB)		
(9) Pixel defect correction	Corrected at ex-factory		
(10) Gain variable range	x1~x32 (0dB~30dB)		
(11) Shutter	Global Shutter		
(12) Shutter speed variable range	Preset : 1/10000, 1/5000, 1/2500, 1/1200, 1/600, 1/300, 1/150, 1/100[us] Manual : 100 [us] ~ approx. 1/frame rate[us]		
(13) Gamma correction	1 fixed		
(14) Trigger mode	Free run mode (Camera internal trigger) Trigger mode <ul style="list-style-type: none"> ▪ Preset shutter trigger ▪ Pulse width shutter trigger 		
(15) Partial scan (ROI)	8 preset patterns. ※Including full resolution (ROI OFF).		
(16) Power requirements	PoCXP		
(17) Power consumption	3.6W (CXP-6) [at free run, full resolution]		
(18) Dimensions	H:29mm W:29mm D:55mm ※without protruding portion		
(19) Weight	Approx. 75 g		
(20) Lens mount	C Mount		
(21) Safety/Quality standards	UL: Conform to UL standard including materials and others.		
	CE: EMC: 2014/30/EU Conform to EN61000-6-4:2007+A1:2011 for emission Conform to EN61000-6-2:2005 for immunity		
	RoHS: 2011/65/EU: Conform to EN50581(RoHS2)		
(22) Durability	Vibration	Acceleration	98m/s ² (10G)
		Frequency	20~200 Hz
		Direction	X, Y, and Z 3 directions
		Testing time	120 minutes for each direction
	Shock	No malfunction shall be occurred with 90m/s ² (50G) for ±X,±Y, and ±Z, 6 directions. (Without packaging)	
(23) Operation environment	Operation guaranteed: 0 ~ +45°C, Humidity: 20 ~ 80%RH with no condensation.		
(24) Storage environment	Storage temperature: -25 ~ +60°C, Humidity: 20 ~ 80%RH with no condensation.		

4.2 Camera Output Signal Specifications

(1) Video output data number	The maximum effective video output	2592(H) × 2048(V)	
(2) Video signal output	BNC connector LINK 0	PoCXP	Power, Video, and Superimposed Control signals
(3) Video output format	Tap geometry	1X-1Y	
(4) Video signal output level	White clip level	FFh	At 8bit
	Setup level	CXP-1: 01 -1/+2 CXP-2-6 : 01 ± 01	At 8bit, Gain 0dB
	※With gain up, set up level changes as well. It is adjustable with black level adjustment (Black Offset).		
(5) External trigger signal input	CoaXPress BNC connector	Low speed uplink	20.83Mbps
	Pin No.5 of the 6 pins round connector.	TTL level input	DC 5.0V (Max. 5.5V)
(6) General signal output	Pin No. 3 of the 6 pins round connector.	EXPOSURE, FVAL, LVAL, and Uplink Triger (After decoding).	With register settings, 1 can be output. 5V output

4.3 Spectral Response

※Refer to the data for NIR. The lens characteristic and the illuminant characteristics are excluded.

Quantum Efficiency

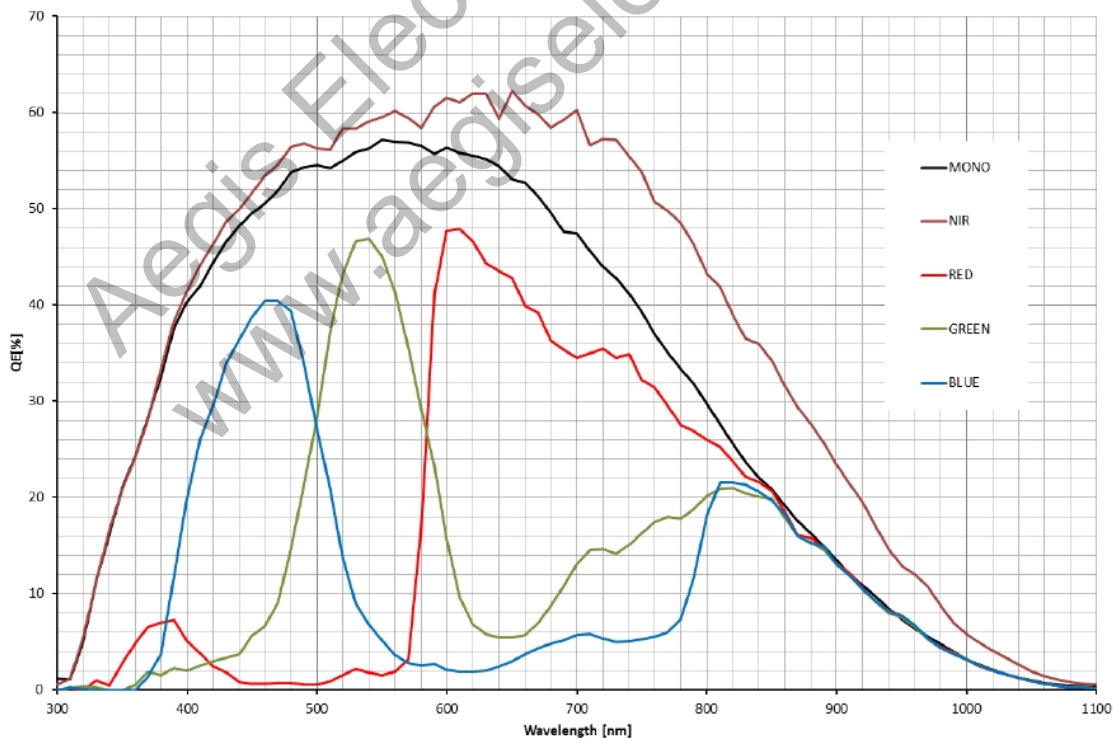
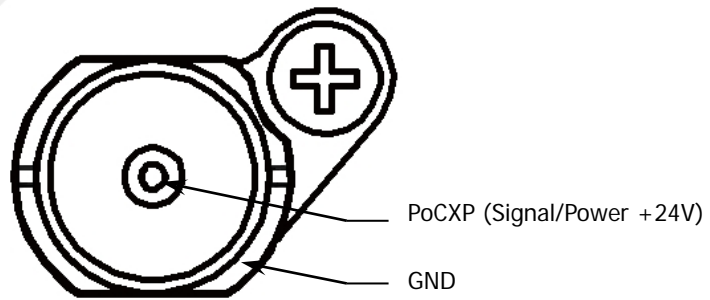

Figure 3. Quantum Efficiency Curves

5. External Connector Pin Assignment

5.1 75Ω BNC Connector



(BCJ-BPLHA CANARE)

5.2 6pins Circular Connector

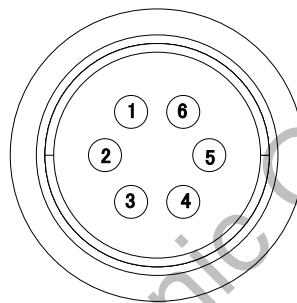

(SNH-8-6(RPCB) SamWoo Electronics)

Pin No.	Signals	Note
1	NC	
2	NC	
3	SIGNAL_OUT	The output of the selected signal
4	NC	
5	TRIGGER_IN	Trigger input
6	GND	Conduction with camera casing

※NC means Non-Connection. Do not connect anything to the terminal.

□ 3pins SIGNAL_OUT Circuit

The camera internal timing signals can be output. Please set the signal to be output from Line Source of Digital IO Control. For the details, please refer to the Section 8.

- 5.0V CMOS logic level output
- Output voltage Low: 0.55Vdc (Max), High: 3.8Vdc (Min)

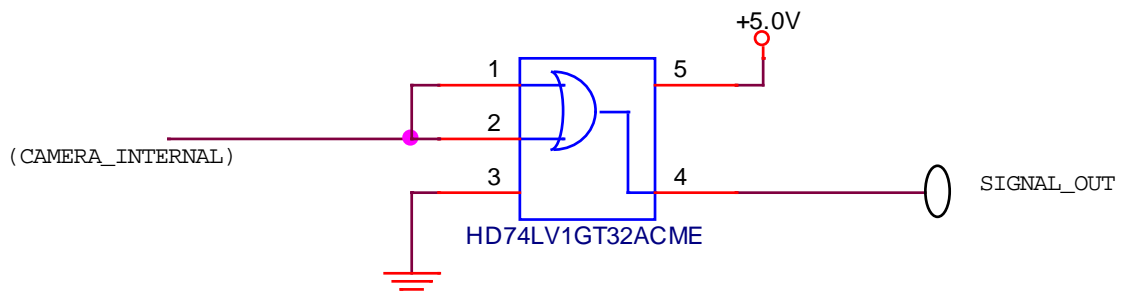

□ 5pins TRIGGER_IN Circuit

Trigger signals can be input from an external equipment directly into the camera. When you use this terminal, set TriggerSource of Acquisition Control to Line IN. For the details, please refer to the Section 7.

- 5.0V, 3.3V CMOS level input (TTL compatible)
- Input voltage Low: 0.5Vdc (Min), High: 2.1Vdc (Max)

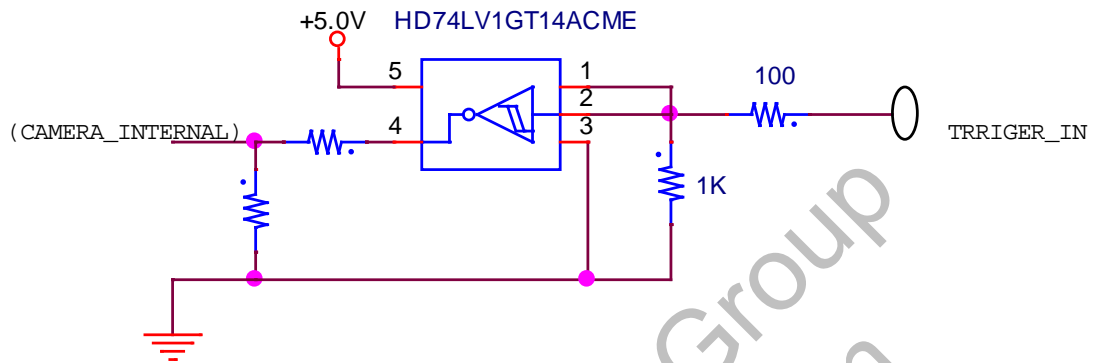

6. How to Save and Initialize the Settings

UserSets	
UserSetSave	(Execute)
UserSetDefault	(Execute)

When UserSetDefault is executed, settings shall be restored to the initial settings. This can be done only when its link configuration (CxpLinkConfiguration) is CXP-1. Unless otherwise UserSetSave is executed, the settings would not be saved. If you wish to save the setting values, execute UserSetSave. Doing so, the setting values are saved in the camera internal ROM. And, the saved settings are reflected when the camera is turned on next time.

7. Camera Operational Mode

7.1 Link Configuration

Transfer Control	
CxpLinkConfiguration	CXP1_X1
	CXP2_X1
	CXP3_X1
	CXP5_X1
	CXP6_X1

7.2 Pixel Format Settings

ImageFormatControl	
PixelFormat	Mono8 Mono10

7.3 Camera Sync. Mode

Acquisition Control	
TriggerSelectorAndActivation	AquisitionMode FrameStartRisingEdge FrameStartFallingEdge FrameStartLevelHigh FrameStartLevelLow FrameBurstStart
TriggerSource	LinkTrigger0 Line0
TriggerSoftware	(Execute)

- TriggerSelectorAndActivation
 - AquisitionMode : Internal sync. mode (Free run mode)
 - FrameStartRisingEdge : External trigger sync. mode (Fixed trigger shutter mode: rising edge)
 - FrameStartFallingEdge : External trigger sync. mode (Fixed trigger shutter mode: falling edge)
 - FrameStartLevelHigh : External trigger sync. mode (Pulse width trigger shutter mode: High active)
 - FrameStartLevelLow : External trigger sync. mode (Pulse width trigger shutter mode: Low active)
 - FrameBurstStart : Internal sync. mode (Burst mode of Sequence function)
- TriggerSource

This is to set how to input the trigger at external trigger sync. mode.

LinkTrigger0: Using LOW SPEED uplink of CoaXPress, input triggers from a frame grabber board via coaxial cable.

LineIn: Input triggers via No. 5 pin of the circular connector on the camera rear.
- TriggerSoftware

When this command is executed, a trigger is generated in the camera and images for 1 frame are captured. Please be noted that time accuracy with this trigger is not so precise as the trigger generated by TriggerSource explained the above. Only TriggerSelectorAndActivation--- FrameStartRisingEdge mode can be used as Acquisition Control mode.

7.3.1 Internal Sync. Mode (Free Run Mode)

This is a mode to use triggers continuously made in the camera. No external trigger shall be used.

Configuration	Frame rate (fps)	
	8bit	10bit
CXP-1	21.3	16.3
CXP-2	42.6	34.8
CXP-3	42.6	42.6
CXP-5	85.1	69.5
CXP-6	85.1	85.1

7.3.2 External Trigger Sync. Mode

This is a mode to input external trigger signals to capture images by any preferred timings. Some delay shall be considered from when camera recognizes the trigger edge to when actual exposure starts. Please refer to below for the delay time.

Input	Delay Time
LinkTrigger0	Approx. 3.4us
Line0	Approx. 150ns

- Notes for trigger pulse input timing

A trigger pulse for the next frame can be input while reading out. However, please do not input a trigger pulse to end exposure while reading out signals for the prior frame. (In other words, please avoid inputting a trigger to start reading the next frame while reading out signals for the prior frame.)

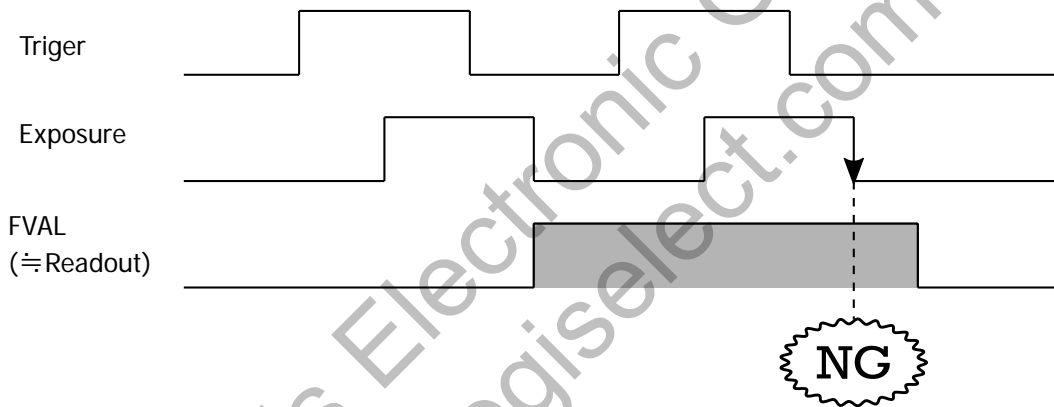

No video would be output in case of when a trigger was re-input at the restricted timing explained the above, or at the timing to end exposure right after FVAL became "L". In such cases or when proper images cannot be output, stop inputting a trigger, then execute "SensorReset" command to re-start.

※ Should it cannot be solved, please reboot the camera.

Device Control	
SensorReset	(Execute)

- Notes for the delay time between trigger pulse and actual exposure start.

Due to the image sensor's features, there will be a timing difference between normal readout operation (exposure for the next frame starts after reading out completes.) and overlapping readout operation (exposure for the next frame starts while reading out.). There are some gap of timing between when a trigger is input to the image sensor, and when exposure actually starts.

- Entire pixels (ROI_OFF)

Link rate	CXP1	CXP2	CXP3	CXP5	CXP6
Exposure delay at normal readout [μ s] * Exposure delay time (A) on Timing chart	4	8	8	4	4
Exposure delay at overlapping [μ s] * Exposure delay time (B) on Timing chart	26-49	19-31	19-31	9-15	9-15

- Sub-sampling

Link rate	CXP1	CXP2	CXP3	CXP5	CXP6
Exposure delay at normal readout [μ s] * Exposure delay time (A) on Timing chart	4	8	8	4	4
Exposure delay at overlapping [μ s] * Exposure delay time (B) on Timing chart	18-34	14-22	14-22	7-11	7-11

* The variable value of delay time is determined depending on the settings of its frame rate and exposure time. Values shall not be changed randomly under fixed condition.

- Fixed trigger shutter mode

This is a mode to start exposure by inputting trigger signals, and to set its exposure time manually or with preset.

- Set "TriggerSelectorAndActivation" to "FrameStartRisingEdge" or "FrameStartFallingEdge."
- Trigger cycle needs to be longer than FVAL period ($\approx 1/\text{framerate}$).
- Trigger cycle needs to be longer than exposure time.
- Trigger operation is CLK sync H-V sync reset.
- Trigger pulse more than 30 μ s width can be input.
- The maximum exposure time depends on ROI settings, "PixelFormat", and link configuration.

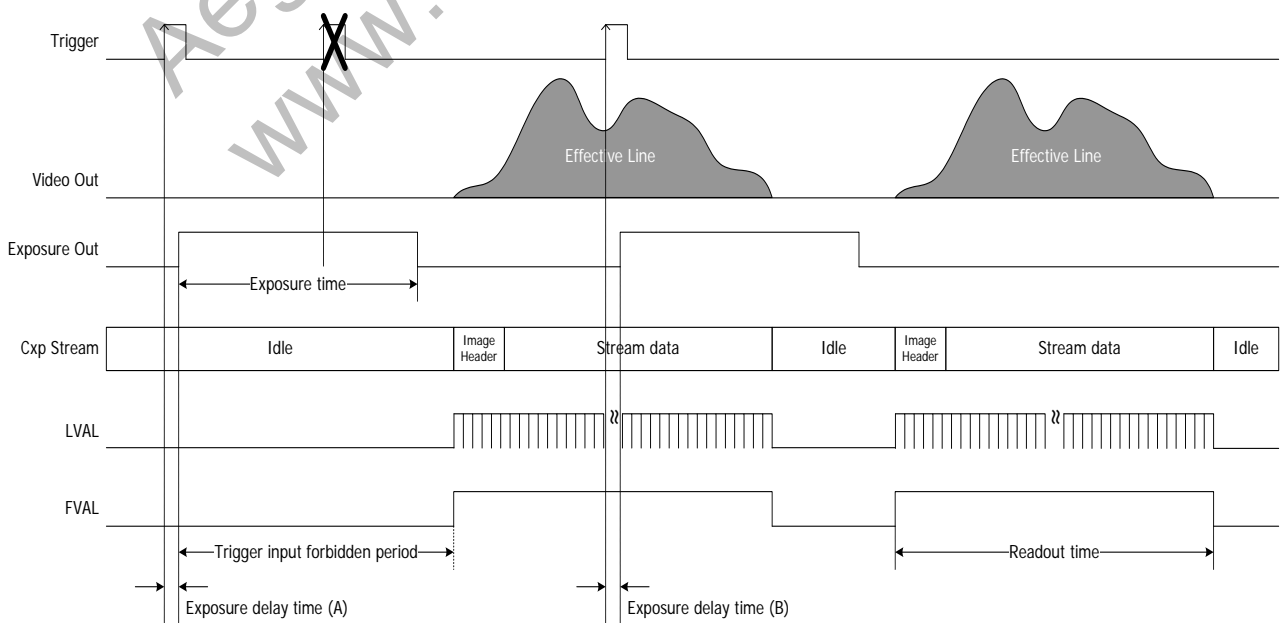

Pulse Width Trigger Shutter Mode

This is a mode to start exposure by inputting trigger signals, and to set its exposure time with trigger pulse width.

- Set "TriggerSelectorAndActivation" to "FrameStartLevelHigh" or "FrameStartLevelLow".
- Trigger cycle needs to be longer than FVAL period ($\cong 1/\text{framerate}$).
- Trigger operation is CLK sync H-V sync reset.
- The minimum trigger width is 30 μs .
- Functionally, there is no upper limitation for pulse width. However, at long exposure, some noises, lines, pixel-wise FPN, and shading might be noticeable.

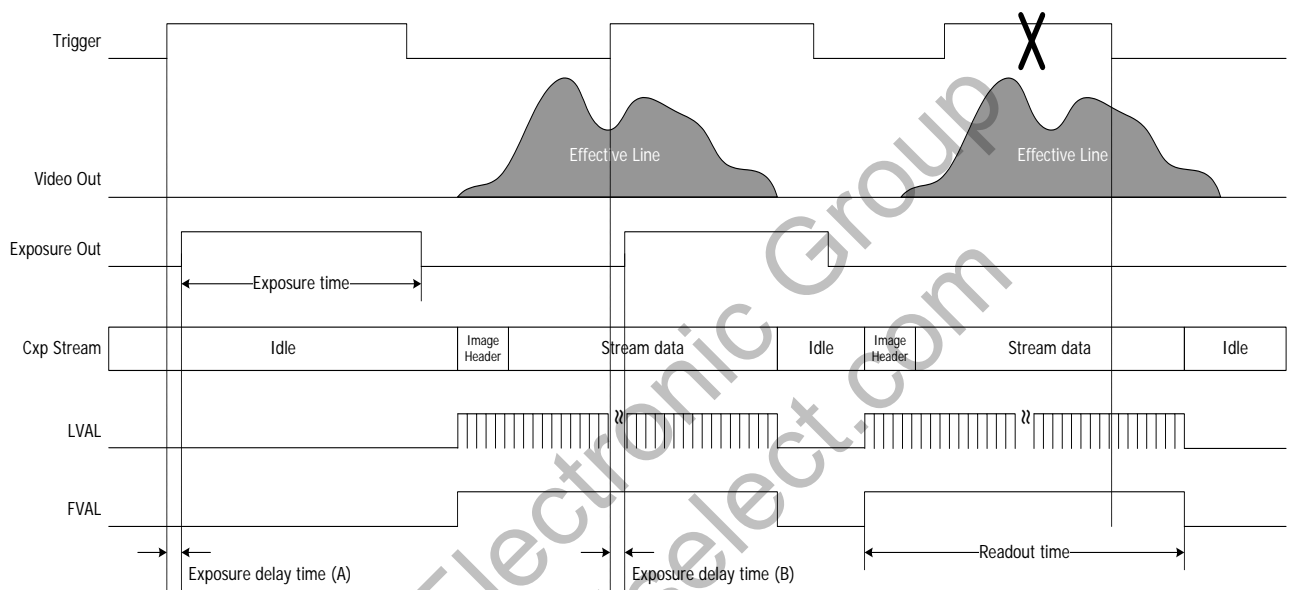

8. Camera Function Settings

8.1 Gain Settings

This is to increase the video out level with the preset gain or manual gain. The setting values are powered values. When the preset values are set, those are reflected to manual setting values.

- ※ Gain up function is up to +32 times. However, please be noted that the image quality will be reduced when gain setting is increased. We recommend you to evaluate it first.

AnalogControl	
PresetGainX	Gain_x1
	Gain_x1_5
	Gain_x2
	Gain_x3
	Gain_x4
	Gain_x6
	Gain_x8
Gain	(Manual)

- PresetGainX: Preset Gain
Preset gain settings are reflected to the manual gain settings.

PresetGainX	Magnification	Converted values
Gain_x1	x1	0dB
Gain_x1_5	x1.5	3.5dB
Gain_x2	x2	6dB
Gain_x3	x3	9.5dB
Gain_x4	x4	12dB
Gain_x6	x6	15.6dB
Gain_x8	x8	18dB

- Gain: Manual gain
Any preferred values from x1 to x32 can be set per x0.25.

8.2 Exposure Time Settings

This is to set exposure time. Exposure time can be set with preset values or manual set values.

Acquisition Control	
PresetShutter1_Xs	Shutter_1_100
	Shutter_1_150
	Shutter_1_300
	Shutter_1_600
	Shutter_1_1200
	Shutter_1_2500
	Shutter_1_5000
	Shutter_1_10000
ExposureTime	(Manual)

- **PresetShutter1_Xs:** Preset shutter mode
Preset values are reflected to the manual settings, Exposure Time. Execution is limited by the image size (ROI) and frame rate.

PresetShutter_1_Xs	Shutter (s)	Converted Time
Shutter_1_100	1/100	10ms
Shutter_1_150	1/150	6.7ms
Shutter_1_300	1/300	3.3ms
Shutter_1_600	1/600	1.7ms
Shutter_1_1200	1/1200	833us
Shutter_1_2500	1/2500	400us
Shutter_1_5000	1/5000	200us
Shutter_1_10000	1/10000	100us

- **ExposureTime:** Manual shutter mode
The maximum exposure time is limited according to the video output format, link rate, and ROI settings. Please refer to the chart below.

(Unit:us)

ROIQuick Change-	8Bit					10Bit				
	CXP1	CXP2	CXP3	CXP5	CXP6	CXP1	CXP2	CXP3	CXP5	CXP6
Off	46650	23360	23360	11680	11680	57270	28500	23300	14300	11550
Pattern1	39000	19300	19300	9510	9510	45600	22660	19300	11120	9520
Pattern2	21950	10890	10890	5340	5340	25210	12600	10850	6130	5300
Pattern3	19250	9550	9550	4640	4640	21200	10590	9510	5190	4640
Pattern4	14200	6960	6960	3410	3410	14650	7120	6980	3510	3410
Pattern5	12450	6070	6070	2920	2920	12440	6070	6070	2920	2920
Pattern6	6580	3110	3110	1450	1450	6580	3110	3110	1450	1450
Pattern7	4750	2370	2370	1160	1160	4750	2370	2370	1160	1160

	8Bit					10Bit				
	CXP1	CXP2	CXP3	CXP5	CXP6	CXP1	CXP2	CXP3	CXP5	CXP6
Sub-sampling	14190	7080	7080	3520	3520	14530	7260	7090	3630	3550

8.3 ROI (Region of Interest)

This is a mode to increase its frame rate by cutting out and reducing the read out area. One area out of seven preset patterns can be selected.

ImageFormatControl
ROIQuickChangePattern1 - 7
ROIQuickChangeOff

- This mode cannot be used with sub-sampling mode.
- Execute re-grabbing the viewer to acquire images.
- According to ROI mode and exposure timing, exposure end timing of image sensor might appear as a pale horizontal line.

ROI Quick Change-	Pixel numbers	Known as	Frame rate (fps)					
				CXP-1	CXP-2	CXP-3	CXP-5	CXP-6
Off	2592x2048	5.2M	8bit	21.3	42.6	42.6	85.1	85.1
			10bi	16.3	34.8	42.6	69.5	85.1
Pattern1	2048x2048	2K2K(4M)	8bit	21.5	51.0	51.0	101.4	101.4
			10bi	19.2	43.5	51.0	85.8	101.4
Pattern2	1920x1200	WUXGA	8bit	41.7	90.1	90.1	179.4	179.4
			10bi	37.4	77.8	90.1	155.6	179.4
Pattern3	1600x1200	UXGA	8bit	45.8	102.2	102.2	204.4	204.4
			10bi	40.7	92.5	102.2	185.0	204.4
Pattern4	1280x1024	SXGA	8bit	64.9	138.4	138.4	274.7	274.7
			10bi	61.0	135.2	138.4	266.3	274.7
Pattern5	1024x1024	1K1K(1M)	8bit	73.2	158.4	158.4	313.9	313.9
			10bi	64.6	158.4	158.4	313.9	313.9
Pattern6	800x600	SVGA	8bit	137.3	297.9	297.9	585.9	585.9
			10bi	122.1	297.9	297.9	585.9	585.9
Pattern7	640x480	VGA	8bit	199.8	399.5	399.5	799.0	799.0
			10bi	183.1	399.5	399.5	799.0	799.0

- The following information on the selected ROI area can be read out.

ImageFormatControl
Width
Height
OffsetX
OffsetY

- ROI area are cut out with the image sensor centered.

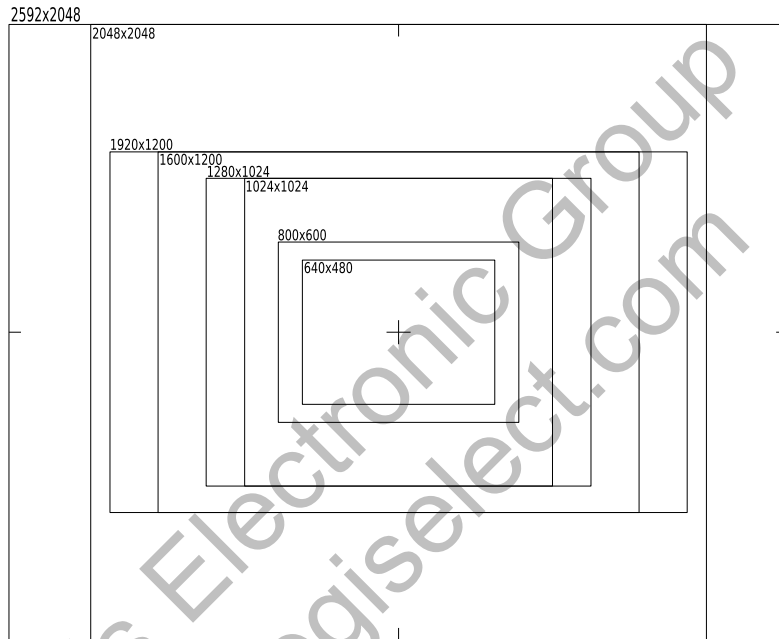
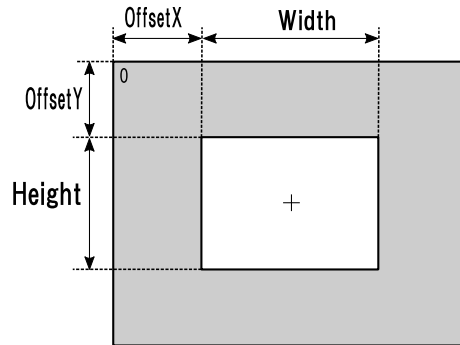

Aegis Electronic Group
www.aegiselect.com

8.4 Sub-sampling

This is a mode to increase its frame rate by reducing the pixel numbers to read out, reducing both horizontal and vertical pixel number in half, that is, 1/4 of the entire pixels. The field angle remains the same as the one for full resolution.

ImageFormatControl	
SubsamplingMode	Subsampling_On
	Subsampling_Off

- This mode cannot be used with ROI mode.
- Execute re-grabbing the viewer to acquire images.
- The frame rates when sub-sampling is in operation at free run mode are as follows.

Configuration	Frame rate (fps)	
	8bit	10bit
CXP-1	64.6	57.8
CXP-2	138.6	135.4
CXP-3	138.6	138.6
CXP-5	277.1	270.4
CXP-6	277.1	277.1

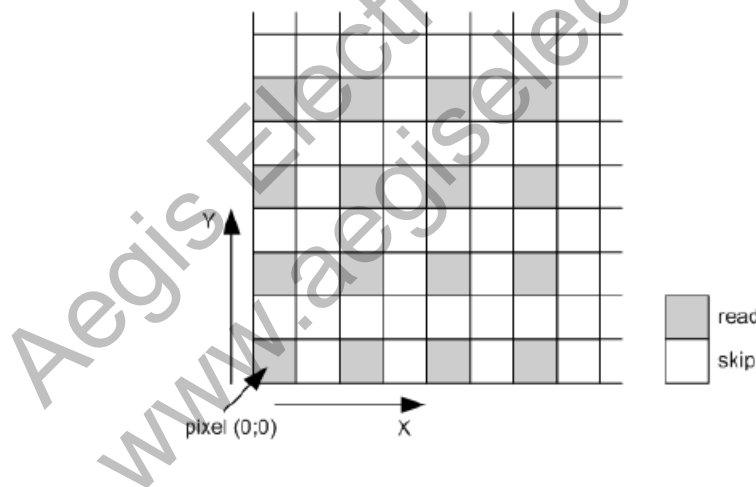

8.5 Image Sensor Defective Pixel Correction

CIS compensates the noticeable CMOS pixel defects found at the shipping inspection prior to our shipment. Defective pixel correction can be set to OFF.

AnalogControl	
DefectivePixelCorrection	True
	False

8.6 Shading Correction

This is a function to correct the peripheral brightness lowering caused by the lens and others used.

AnalogControl	
ShaddingCorrection	True
	False
DetectShading	(Execute)

- Shading detection (DetectShading)
 - Shoot a uniform object such as a pattern box to full screen, then execute DetectShading to calculate and save the correction data automatically in the camera.
- ※ When detect shading, please turn OFF ROI, sub-sampling, and shading correction.
- ※ Shading detection does not operate properly without video output when trigger mode is in operation.
 - To execute DetectShading, please input a trigger within 200ms after executed DetectShading.
- ※ When obtain correction data with trigger shutter mode, the data sometimes becomes unstable. In this case, change the trigger cycle in small measure and obtain correction data again.
- Shading correction (ShadingCorrection)
 - Turn Shading Correction ON to execute shading correction function on the images according to the data made by shading detection.

◆ Before Shading Correction



◆ After Shading Correction



8.7 Black Offset

AnalogControl	
BlackOffset	0~255

- The default value is 64.
- Black level is adjustable with relative values. When it is increased or decreased by 1, its luminance level changes by approx. 0.25 at 8 bit output, and it changes by approx. 1.0 at 10 bit output.
- When a lower value than the initial value is set, saturation level would not achieve to the maximum value for output range.

8.8 Test Pattern

ImageFormatControl	
TestImageMode	OFF/ON

Test pattern can be output via the camera. This is useful to check if the system is operating properly.



8.9 LED Indicator

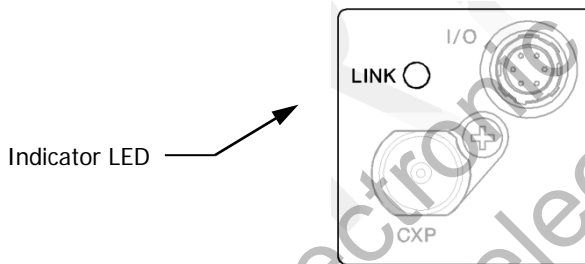

DeviceControl	
DeviceIndicatorMode	Active ErrorStatus Inactive

- Active : This is to indicate the communication status of CoaXPress.
- ErrorStatus : Normally the light is OFF. However, the light turns ON when system error occurs.
- Inactive : LED OFF.

Please refer to the chart below for the lighting pattern at Active setting.

Lighting status	Camera Status
OFF	PoCXP No supply
Green Slow blinking [0.5Hz]	Connection completed between device and host
Green ON	Transmitting video data
Orange Slow blinking [1Hz]	Waiting for a trigger input
Red Fast blinking	System error occurred

※ The camera might work fine even when the red light is blinking. Also, please be noted that the camera would remain indicating error, once the camera recognized an error, such as when a trigger was input in the restricted timing, or when ROI or sub-sampling function was activated while grabbing images. Please reboot the camera, or execute Device Control – SensorReset to revert the camera to normal lighting condition.

8.10 Camera Timing Output

The following signals can be output via 6pins circular connector on the camera rear according to the settings of LineSource.

Digital IO Control	
LineSelector	Line1
LineMode	Output
LineSource	OFF ExposureActive FrameActive LineActive TriggerPacketActive

- LineSource

- ExposureActive : This is to indicate the exposure period of the image sensor with Hi Active.
- FrameActive : This is to indicate the frame effective period with Hi Active.
- LineActive : This is to indicate the line effective period with Hi Active.
- TriggerPacketActive : This is to decode and output the uplink trigger packet signals from the frame grabber board.

8.11 DeviceUserID Setting

DeviceControl	
DeviceUserID	[User Definition]

A user-defined device name can be set in the camera with the maximum of sixteen characters letter string. Execute "UserSetSave" to save the user-defined device name in EEPROM in the camera.

Execute "UserDefault" to restore to the factory settings.

※ Register area is 16 byte in total. Please input single-byte alphanumeric characters.

9. Sequence Control Function

This is the function to select one set of parameter out of the preset several kinds of parameter sets per trigger input, and apply it to the camera.

- The maximum of sixteen kinds of parameter sets can be set in advance. The following parameters can be set per parameter set.

Settable parameter: Shutter, Gain

- Operational sequence is specified as "Index". Specify the parameter set number to be applied for the maximum of sixteen indexes.
- There are three control modes; Trigger mode, Burst mode, and Index mode.
- Please refer to the chart below for the settable AcquisitionMode (Camera operational mode) and SequencerActivation (Start operation) correspond to each sequence mode.

AcquisitionControl AquisitionMode [TriggerSelectorAndActivation]						
	FrameStartRisingEdge	FrameStartFallingEdge	FrameStartLevelHigh	FrameStartLevelLow	FrameBurstStart	SequencerControl [SequencerActivation]
【Sequence operation mode】						
Trigger mode	⊙	⊙	⊙	⊙		FrameStartPredfined
Index mode	⊙	⊙	⊙	⊙		FrameStartIndexselector
Burst mode					⊙	FrameBurstStartEdge FrameBurstStartLevel FrameBurstStartSoftware

9.1 Basic Operation for Sequence Control

Please follow the step by step instructions below to use sequence control function.

- ① **AquisitionControl --- TriggerSelectorAndActivation Setting**
This is to set camera operational mode.
- ② **Sub-sampling, ROI settings**
Please turn OFF SubsamplingMode. Please set ROI of ImageFormatControl to ROIQuickChangeOff.
This does not work with sequence control function.
- ③ **Set the parameter table (SequencerParameterSetSelector) for sequence**
Please set ExposureTime and Gain of each parameter set.
- ④ **Set the parameter set to be used for sequence (ParameterIndexNumber), index loop count (IndexLoopCount), entire sequence loop count (SequencerLoopCount), and the range of index to be used (ActiveIndexNumber)**
- ⑤ **SequencerControl --- SequencerActivation**
This is to set the start operation of sequence mode. By setting any preferred [SequencerActivation] from Off, the camera will become stand-by status for a trigger.
- ⑥ **Input a trigger pulse to start sequence control function.**

[Notes]

- Please determine link configuration beforehand to set each setting.
- Trigger input timing restrictions at sequence control is the same as the one for normal mode.
- Please turn OFF SequencerActivation once to set the settings for sequence.
- UserSetSave and UserSetDefault are not executed at SequencerMode. Please set them after power up the camera. (UserSetSave and UserSetDefault can be executed for other sequence settings).
- If a trigger had been input to the camera in advance, sequence would start when the SequencerActivation is set to other than OFF. Please do not input any triggers to switch SequencerActivation.
- Please refer to the maximum exposure time specified in the Section 8.2, Exposure Time Settings, for exposure time to input to each parameter settings.
- At burst mode, the screen will hold the last picture of sequence control when sequence control is completed.
- Please turn OFF SequencerActivation to return to the condition before sequence control was performed.

9.2 Trigger Mode and Burst Mode Operational Outline

This is a mode to specify Index transition flow in advance.

The repeating count for each Index, the number of the Index to be used, and the loop count can be set.

- Trigger mode

Index repeat count is added up every time external trigger is input, and the specified parameter set is applied to the camera.

- Burst mode

It operates as the same way as internal sync mode free run. Sequence starts by a trigger, Index repeat count increments automatically by a camera internal trigger, and the specified parameter set is applied to the camera.

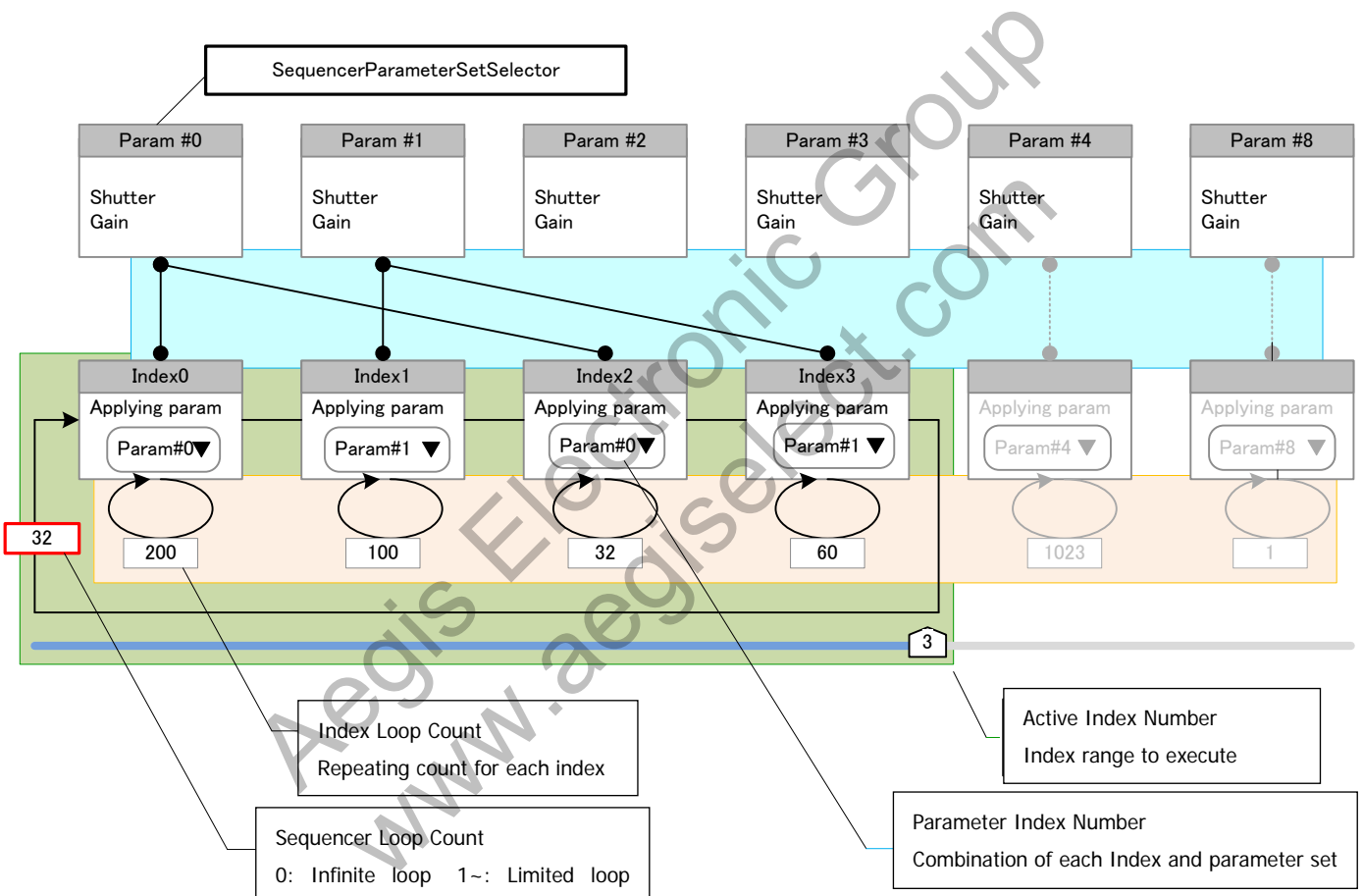

9.3 Trigger Mode

The start and stop of sequence operation are selectable from edge control or pulse width control of trigger input signals.

- As to TriggerSelectorAndActivation, please select one from the below, according to the mode to be used.
FrameStartRisingEdge/ FrameStartFallingEdge/ FrameStartLevelHigh/ FrameStartLevelLow

(1) Edge control

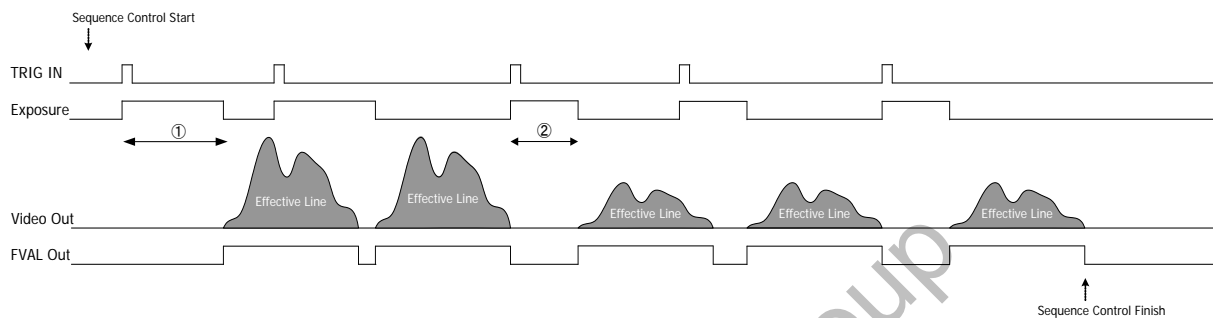

Sequence starts with a trigger input when TriggerSelectorAndActivation is set to FrameStartRisingEdge or FrameStartFallingEdge.

- Exposure time for each frame (① and ②) shall be controlled by the preset sequence parameter set.
- When the image output for the sequence loop count is completed, sequence operation ends.

(2) Pulse width control

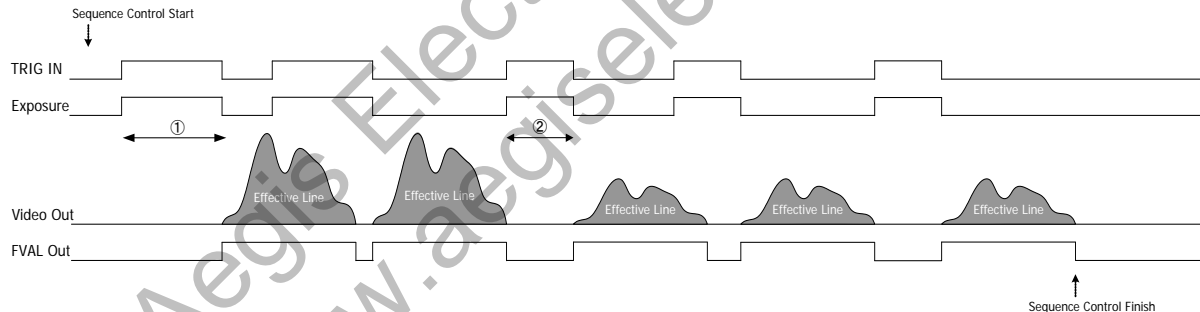

Sequence starts with a trigger input when TriggerSelectorAndActivation is set to FrameStartLevelHigh or FrameStartLevelLow.

- Exposure time for each frame (① and ②) is the pulse width of the trigger.
- When the image output for the sequence loop count is completed, sequence operation ends.

9.4 Burst Mode

The start and stop of sequence operation are selectable from the edge control, level control, and register start of trigger input signals.

- Please set TriggerSelectorAndActivation to FrameBurstStart.

(1) Edge Control

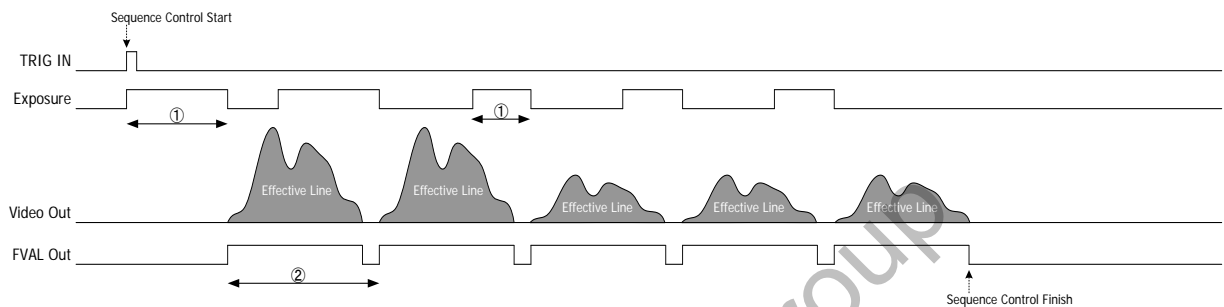

Sequence operation starts with a trigger input when SequencerActivation is set to FrameBurstStartEdge.

- Exposure time for each frame (①) and output frame time (②) shall be controlled by the preset sequence parameter set and the image size settings.
- When the image output for the sequence loop count is completed, sequence operation ends.

(2) High level control

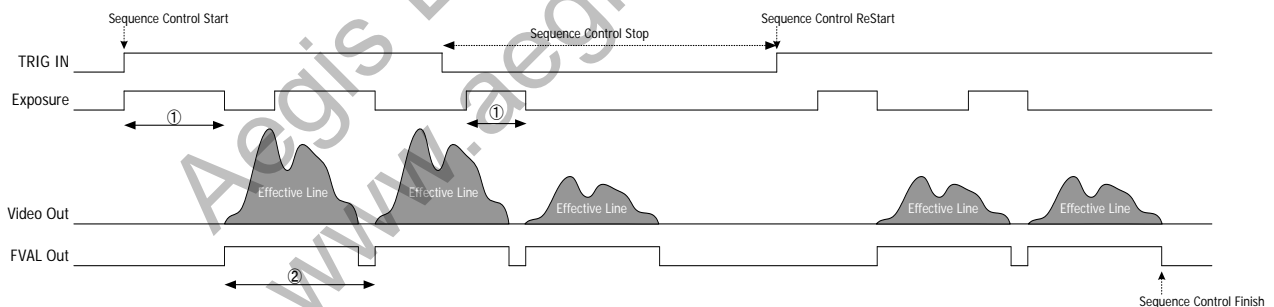

When SequencerActivation is set to FrameBurstStartLevel, sequence operation is performed while the trigger input is at High level.

- Change the trigger input to Low level to stop operation in the middle. (If you wish to completely end the operation, turn sequence control to OFF.)
- Sequence operation restarts and operates continuously when the trigger input is changed to High level again.
- When the image output for the sequence loop count is completed, sequence operation ends.

(3) Register start

Sequence operation starts simultaneously when the SequencerActivation OFF is set to FrameBurstStartSoftware.

9.5 Index Mode

This is a mode to directly specify the Index number to apply by `IndexSelectorModeIndexNumber`.

Every time when a trigger is input, the Index parameter set specified by `IndexSelectorModeIndexNumber` is applied to the camera.

Operational flow chart

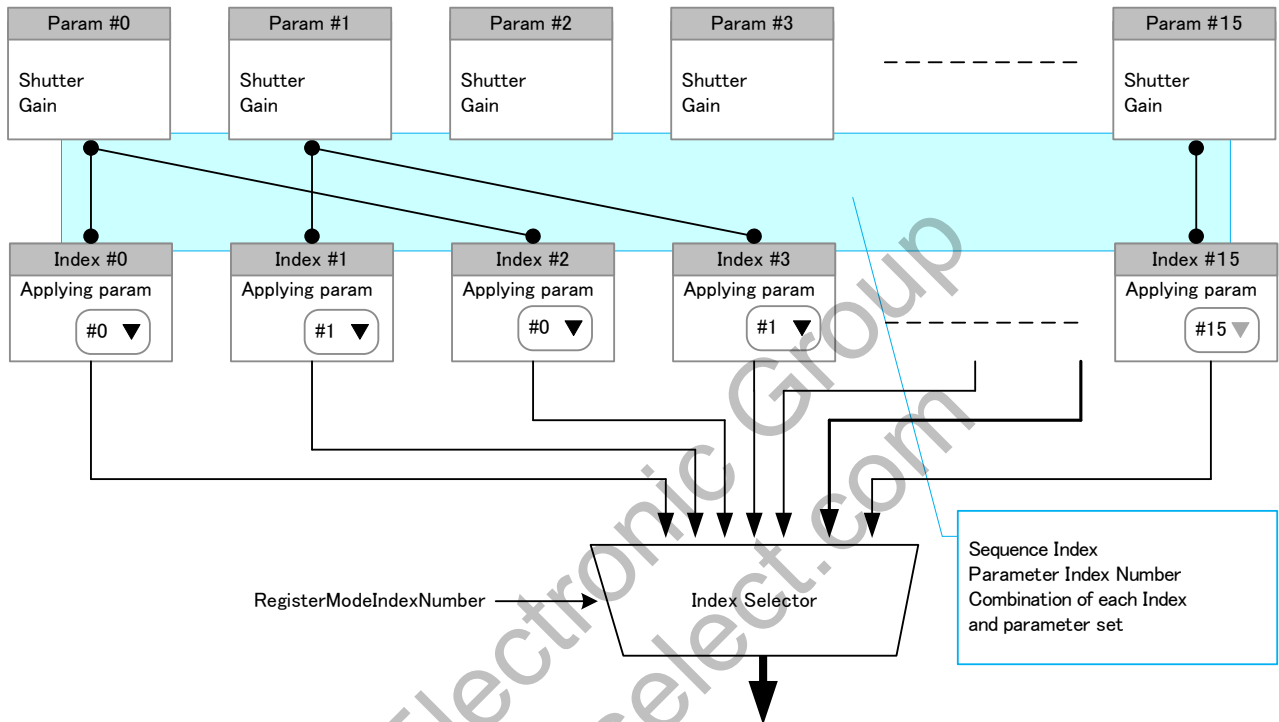

- As to `TriggerSelectorAndActivation`, please select one from the below, according to the mode to be used.
`FrameStartRisingEdge`/ `FrameStartFallingEdge`/ `FrameStartLevelHigh`/ `FrameStartLevelLow`

(1) Edge control

Exposure time for each frame shall be controlled by the preset parameter set.

(2) Pulse width control

Exposure time for each frame is the pulse width of the trigger. Exposure time of the parameter set is not referred.

※ Notes for the issuing timing of `IndexSelectorModeIndexNumber` command

To reflect the specified parameter set surely to the next frame, please issue `IndexSelectorModeIndexNumber`, wait for the response of ACK, and then input a trigger pulse.

9.6 Settings for Sequence Control

Execute UserSetSave to save the settings. Please be noted that SequencerActivation is not saved so that after power is turned on, it always becomes OFF. When using sequence mode, set SequenceActivation every time.

◇ Settings for how to control sequence function

Acquisition Control	
TriggerSelectorAndActivation	AquisitionMode FrameStartRisingEdge FrameStartFallingEdge FrameStartLevelHigh FrameStartLevelLow FrameBurstStart

- FrameStartRisingEdge : Set sequence control to the rising edge control of the trigger pulse.
- FrameStartFallingEdge : Set sequence control to the falling edge control of the trigger pulse.
- FrameStartLevelHigh : Set sequence control to the high level control of the trigger pulse.
- FrameStartLevelLow : Set sequence control to the low level control of the trigger pulse.
- FrameBurstStart : Set when sequence control is used at burst mode.

◇ Settings for how to change to sequence mode

SequencerControl	
SequencerActivation	Off
	FrameStartPredefined
	FrameStartIndexSelector
	FrameBurstStartEdge
	FrameBurstStartLevel
	FrameBurstStartSoftware

- FrameStartPredefined : Set to start trigger mode or burst mode.
- FrameStartIndexSelector : Set to start index mode.
- FrameBurstStartEdge : Set to start burst mode edge control.
- FrameBurstStartLevel : Set to start burst mode High level control.
- FrameBurstStartSoftware : Set to start burst mode register start.

◇ Settings for sequence count and its range

SequencerConfigurationParameter		Setting range
SequencerLoopCount	Entire sequence loop count	1-1023 0: infinite
ActiveIndexNumber	The Index range to execute	0-15
IndexSelectorModeIndexNumber	Index number to be used at index mode	0-15
ParameterIndexNumber		
Index 0-15	Parameter number for Index 0-15	0-15
IndexLoopCount		
IndexCount 0-15	Each loop count for Index 0-15	0-1023

◇ Settings for sequence parameter set

There are sixteen parameter sets. Change the number of SequencerParameterSetSelector to replace the parameter set. The set data are saved even when the parameter number is changed.

SequencerParameterSetSelector	0~15 Parameter set	
SetConfiguration		
	SequencerExposureTime	Exposure time
	(SequencerExposureTimeMAX)	Indicates the maximum exposure time to be set.
	SequencerGain	Gain
	(SequencerXSize)	Set X size specified with ROI
	(SequencerYSize)	Set Y size specified with ROI
	(SequencerXStart)	Set X coordinate specified with ROI
	(SequencerYStart)	Set Y coordinate specified with ROI

Aegis Electronic Group
www.aegiselect.com

9.7 Sequence Status Output

This is to indicate the status of sequence control. The status information can be output by embedding it in the effective image area.

SequencerStatus	
SequencerInformationLocation	Specify the position of status information
Off	Information output OFF
TopLeft	Top left output
TopRight	Top right output
BottomLeft	Bottom left output
BottomRight	Bottom right output
FrameBurstStatus	Indicate the status of burst mode for sequence.
IndexNumberStatus	Indicate the executing Index number.
RepeatNumberStatus	Indicate the repeating count of executing Index number.
LoopNumberStatus	Indicate the loop count of executing sequence. ※If the loop count is set to infinite count, up to 1023 count can be indicated.

The output location of status information can be chosen from four locations as below, and the information shall be embedded in five pixels.

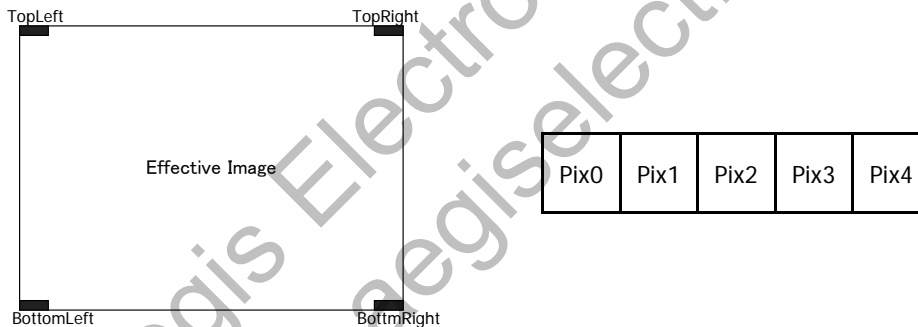

For each pixel, index number, index repeating number, and loop count information are output as follow. In case of 10bit video output, 2bit of LSB side shall always be "00".

	MSB		LSB
pix0	"00"	Index number [3:0]	"0000" "00"
pix1	"00"		Repeating number [7:0] "00"
pix2	"00"	"000000"	Repeating number [9:8] "00"
pix3	"00"		Loop Count [7:0] "00"
pix4	"00"	"000000"	Loop Count [9:8] "00"

10. Factory Settings

Function	Data	Notes
DeviceControl		
DeviceUserID	ID00DevU0000000H	
DeviceIndicatorMode	Active	
ImageFormatControl		
ROIQuickChangeOff	Width : 2592	
	Height : 2048	
	OffsetX : 0	
	OffsetY : 0	
PixelFormat	MONO8	
AquisitionControl		
TriggerSelectorAndActivation	AcquisitionMode	
TriggerSource	LinkTrigger0	
ExposureTime	3333.0	
AnalogControl		
blackOffset	64	
Gain	1.0	
ShadingCorrection	False	
DefectivePixelCorrection	True	
DigitalIOControl		
LineSource	OFF	
SequencerControl		
SequencerActivation	Off	
SequencerInformationLocation	Off	
Index0~Index15	0~15	The same value as the Index number.
Index 0 Count~Index 15 Count	1	All 1
SequencerLoopCount	0	
ActiveIndexModeIndexNumber	0	
SequencerExposureTime	1000.0	(Selector 0-15)
SequencerGain	1.0	(Selector 0-15)
TransportLayer		
CxpLinkConfiguration	CXP_X1	

※ Factory settings are the same values as the one for UserSetDefault command.

11. Dimensions

11.1 Optical Axis Accuracy

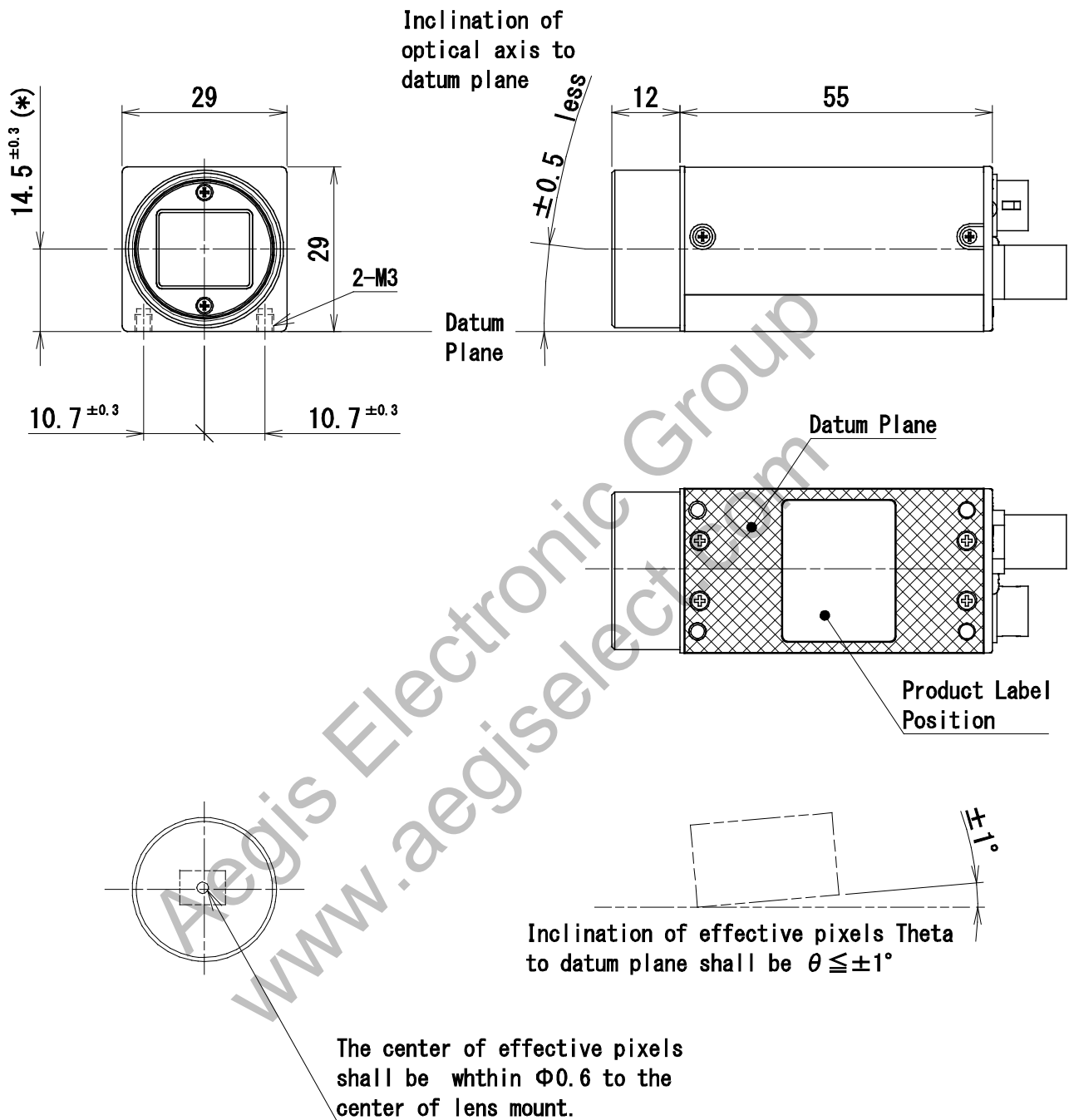

(*)Dimension from datum plane to the center of lens mount.

937-0012-00
 (Unit:mm)

11.2 Camera Dimensions

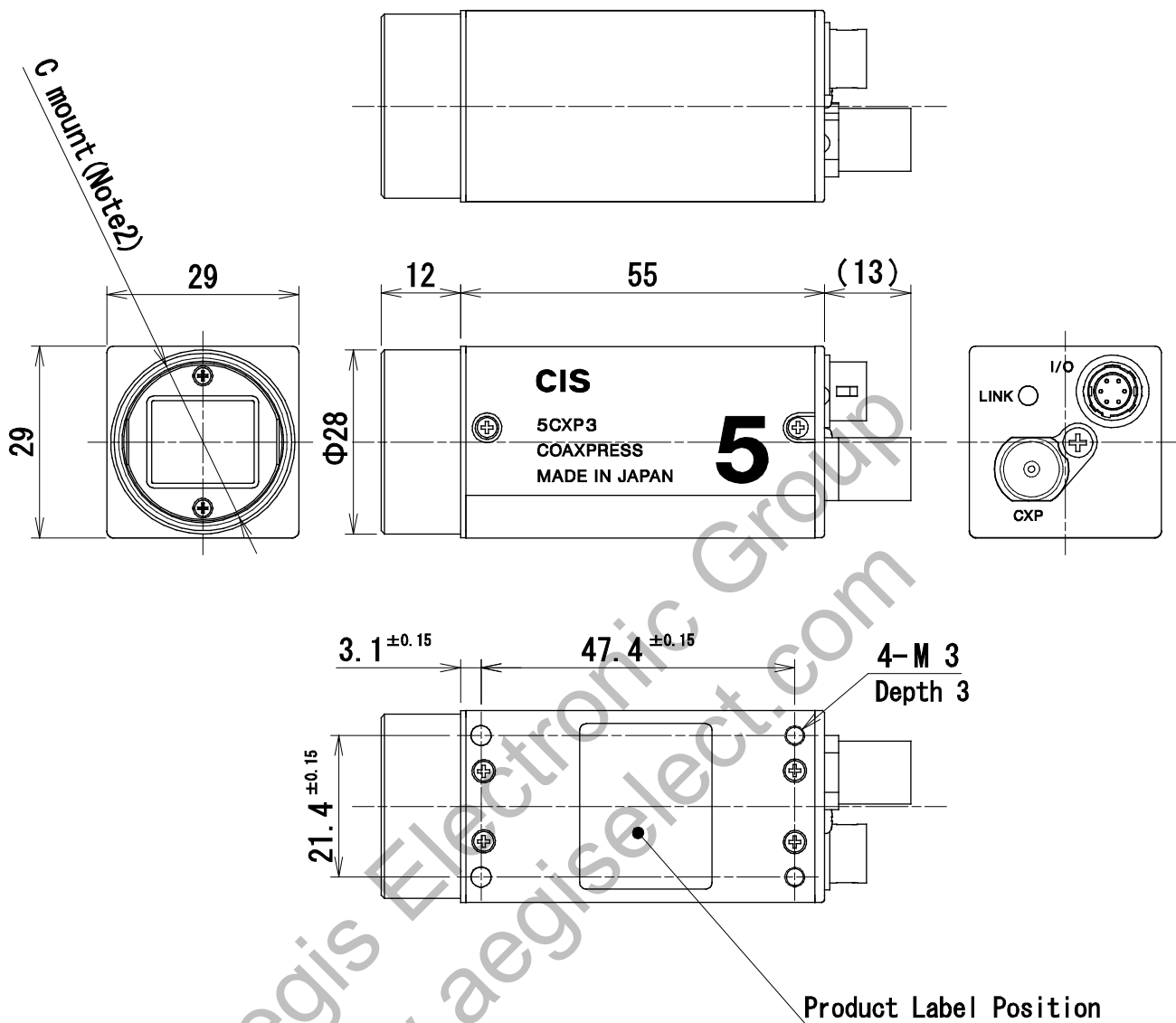

Note2) C mount screws comply with ANSI/ASME B1.1.1-32UN (2B).
 Note1) Screw length from the lens mount surface shall be less than 6 mm. And protruding portion of the C mount lens shall be less than 10 mm.

935-0041-00
 (Unit:mm)

12. Case for Indemnity (Limited Warranty)

The term of warranty of this product is within 3 year from the date of shipping out from our factory.

If you use the product properly and discover a defect during the warranty period, and if that was caused by designing or manufacturing, CIS Corporation, at its option, repairs or replaces it at no charge to you. Products out of warranty period will be subject to charge. CIS repairs the products as long as it is repairable.

CIS shall be exempted from taking responsibility and held harmless for damages or losses incurred by the following cases.

- In case damages or losses are caused by earthquake, lightning strike, fire, or other acts of God.
- In case damages or losses are caused by deliberate or accidental misuse by the user, or failure to observe the information contained in the instructions in this Product Specification and Operational Manual.
- In case damages or losses are caused by repair or modification conducted by the customer or any unauthorized party.

• CMOS Pixel Defect

CIS compensates the noticeable CMOS pixel defects found at the shipping inspection prior to our shipment. On very rare occasions, however, CMOS pixel defects might be noted with time of usage of the products. Cause of the CMOS pixel defect is the characteristic phenomenon of CMOS sensor itself and CIS is exempted from taking any responsibilities for them. Should you have any questions on CMOS pixel defects compensation please contact us.

13. Product Support

Should you have any problems in function of the product you purchased, and if you need our further analysis and/or repair, please contact us.