

---

---

# CIS

**CoaXPress I/F  
VGA CMOS (RAW) Camera**

**VCC-VCXP5R**

**Product Specifications  
& Operational Manual**

**CIS Corporation**

## Table of Contents

1.	Handling Precautions .....	1
1.1.	Camera Handling Precautions.....	1
1.2.	Restrictions on Applications.....	1
1.3.	Disclaimers.....	1
2.	Product Outline .....	2
2.1.	Features.....	2
2.2.	System Configuration .....	2
3.	Specifications.....	3
3.1.	General Specifications .....	3
3.2.	Camera Input and Output Signals Specifications .....	4
3.2.1	TRIGGER_IN Input (6pins Circular Connector No.5 pin).....	4
3.2.2	SIGNAL_OUT Output (6pins Circular Connector No.3 pin) .....	4
3.3.	External Connector Pin Assignment.....	5
3.3.1	6pins Circular Connector.....	5
3.3.2	75ΩBNC Connector .....	5
3.3.3	LED Indicator .....	5
3.4.	Spectral Response.....	6
3.5.	Output Timing .....	7
3.5.1	Horizontal Sync. Timing.....	7
3.5.2	Vertical Sync. Timing.....	8
4.	Camera Function .....	9
4.1.	Setting.....	9
4.2.	How to Save and Initialize the Settings.....	9
4.3.	Link Speed and Link Count.....	9
4.4.	Pixel Format .....	10
4.5.	Flip.....	10
4.6.	Internal Sync. Mode (Free Run Mode).....	10
4.7.	External Trigger Sync. Mode.....	11
4.8.	Trigger Sync. Mode and Delay Time to Start Exposure.....	13
4.9.	Restrictions on Trigger Pulse Input Timing.....	13
4.10.	Fixed Trigger Shutter Mode (LineSync.) H Sync. Trigger .....	14
4.11.	FAST Fixed Trigger Shutter Mode (ClockSync.) CLK Sync. Trigger.....	15
4.12.	Pulse Width Trigger Shutter Mode (LineSync.) H Sync. Trigger.....	15
4.13.	FAST Pulse Width Trigger Shutter Mode (ClockSync.) CLK Sync. Trigger .....	17
4.14.	Exposure Time.....	18
4.15.	Formula to Calculate Manual Shutter Values with H Sync Mode.....	18
4.16.	Manual Shutter Settings with CLK Sync. Mode (FAST Trigger Mode).....	18
4.17.	Gain.....	18
4.18.	Gamma Correction .....	19
4.19.	Sensor Black Level Adjustment.....	19
4.20.	Partial Scan (ROI).....	19
4.21.	Defective Pixels Correction.....	20
4.22.	Test Pattern Indication.....	24
4.23.	Cursor Indication .....	24
4.24.	LED Operational Mode.....	25
4.25.	Camera Timing Output .....	25
4.26.	User ID Save .....	25
4.27.	Temperature Indication.....	25

---

4.28.	White Balance.....	26
5.	Factory Settings .....	27
6.	Dimensions.....	28
6.1.	Camera Dimensions.....	28
6.2.	Optical Axis Accuracy.....	29
7.	Case for Indemnity .....	30
7.1.	Product Warranty .....	30
7.2.	CMOS Pixel Defect.....	30
7.3.	Product Support.....	30

Aegis Electronic Group  
www.aegiselect.com

## 1. Handling Precautions

### 1.1. Camera Handling Precautions

- Do not use or store the camera in the extremely dusty or humid places.
- Do not apply excessive force or static electricity that could damage the camera. Handle the camera with care.
- Do not shoot direct images that are extremely bright (e.g., strong light source, sun, etc.). When strong light such as spot light was shot, blooming or smear may occur. Put the lens cap on when camera is not in use.
- Follow the instructions in [Chapter 3.3, "External Connector Pin Assignment"](#) for connecting the camera module. Improper connection may cause damages not only to the camera module but also to the connected devices.
- Confirm the mutual ground potential carefully before connecting the camera to monitors or computers. Any AC leaks from the connected devices may cause damages or destroy the camera.
- Do not apply excessive voltage. (Use only the specified voltage.) Unstable or improper power supply voltage may cause damages or malfunction of the camera assembly.
- Our warranty does not apply to damages or defects caused by irregular and/or abnormal use of the product.

### 1.2. Restrictions on Applications

- The camera must not be used for any nuclear equipment or aerospace equipment with which mechanical failure or malfunction could result in serious bodily injury or loss of human life.
- The camera must not be used under conditions or environments other than specified in this manual.

### 1.3. Disclaimers

- In case damages or losses are caused by earthquake, lightning strike, fire, flood, or other acts of God.
- In case damages or losses are caused by deliberate or accidental misuse by the user, or failure to observe the information contained in the instructions in this Product Specification and Operational Manual.
- In case damages or losses are caused by repair or modification conducted by the customer or any unauthorized party.

## 2. Product Outline

VCC-VCXP5R is a CoaXPress interfaced and 0.4M resolution camera module. 1/2.9 type CMOS sensor is utilized.

### 2.1. Features

- Small footprint: 29mm cubic in size
- Global shutter type CMOS sensor (Color)
- CoaXPress CXP-3
- 1 lane
- Max. cable length: Approx. 100m (At CXP-3)
- Partial scan
- Exposure and Gain settings
- External trigger mode (Fixed trigger shutter mode / Pulse width trigger shutter mode)
- GenICam complied
- C mount

### 2.2. System Configuration

- Camera
  - ◆ Camera, VCC-VCXP5R
  - ◆ Lens mount cap
- Packaging
  - ◆ Individual carton
  - ◆ Master carton (10pcs/carton)
    - Note) Master carton may vary depends on the quantity to be shipped.

## 3. Specifications

## 3.1. General Specifications

<b>Electrical Specifications</b>			
Pick up device	Device type	1/2.9 type Global shutter CMOS	
	Effective pixel number	728(H) × 544(V)	
	Unit cell size	6.9μm(H) × 6.9μm(V)	
Video output mode		CoaXPress Ver,1.1.1 complied, CXP3x1	
Video output frequency	Standard pixel clock frequency	74.25MHz	
Video output format		Mono 8 / Mono 10 / Mono 12 / BayerRG8 / BayerRG10 / BayerRG12	
Frame rate	CXP3 8bit/10bit/12bit	523fps/437fps/320fps	
Sync. system		Internal sync. system	
Resolution (The maximum pixel size)		720 (H) × 540(V)	
Video signals (Gain 0dB)	White clip level	255	At MONO 8bit
	Set up level	0~2	At MONO 8bit
	Dark shading	4dig or less for both horizontal and vertical.	At MONO 8bit
Sensitivity		12bit/10bit Mode F11 2000lx 3200K 1/30s Gain 0dB 8bit Mode F22 2000lx 3200K 1/30s Gain 0dB	
Minimum illumination		12bit/10bit Mode 0.3lx (F1.4, Gain 42dB, 1/30s, Level=50%) 8bit Mode 0.2lx (F1.4, Gain 42dB, 1/30s, Level=50%)	
Gain variable range		x1~x256 (0dB~+48dB)	
Shutter speed		Manual settings	
Gamma correction		Valid (0.10~1.80 of coefficient can be set.)	
Trigger mode		Free run mode (Camera internal trigger) Trigger mode (Host, External terminal) •Fixed trigger shutter •Pulse width trigger shutter	
Partial scan		Vertical 1 area can be set.	
Power requirements		PoCXP: 18.5V~26V	
Power consumption		2.4W(CXP-3) [At free run]	
<b>Mechanical Specifications</b>			
Dimensions		H:29mm W:29mm D:29mm (Without protruding portion)	
Weight		Approx. 50g	
Lens mount		C mount	
<b>Environmental Specifications</b>			
Safety/Quality standard		UL: Conform to UL for all materials. CE: EMC 2014/30/EU EN61000-6-4:2007+A1:2011 for Emission EN61000-6-2:2005 for Immunity	
		RoHS: 2015/863/EU EN50581 (RoHS2)	

Durability	Vibration	Acceleration	: 98m/s <sup>2</sup> (10G)
		Frequency	: 20 ~ 200Hz
		Direction	: X, Y, and Z 3 directions
		Testing time	: 120min for each direction
	Shock	No malfunction shall be occurred with 980m/s <sup>2</sup> (100G) for ±X,±Y, and ±Z, 6 directions without packaging.	
Operation guaranteed temperature		0 ~ +45°C Humidity: 20 ~ 80%RH with no condensation.	
Storage temperature		-30 ~ +60°C Humidity: 20 ~ 80%RH with no condensation.	

3.2. Camera Input and Output Signals Specifications

3.2.1 TRIGGER\_IN Input (6pins Circular Connector No.5 pin)

- 5.0V, 3.3V CMOS level / TTL level
- Input voltage Low: 0.5Vdc (Max.), High: 2.1Vdc (Min.)
- Trigger can be input directly from the external equipment. If you wish to use this terminal, please set TriggerSource of AcquisitionControl to Line0.

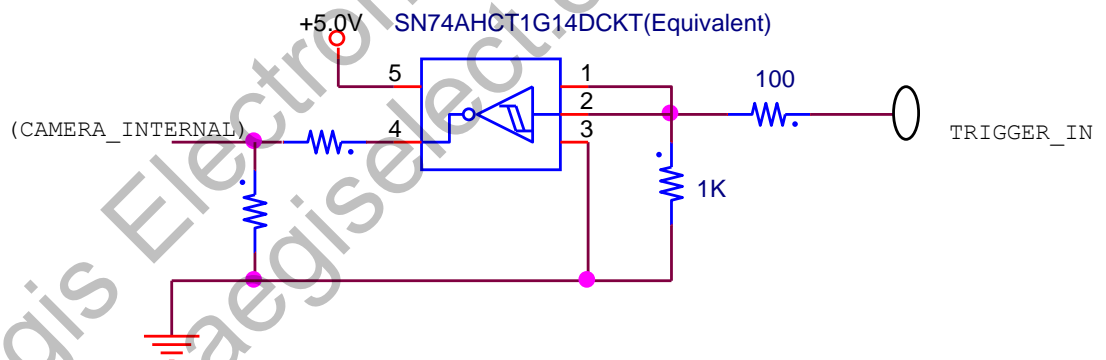

3.2.2 SIGNAL\_OUT Output (6pins Circular Connector No.3 pin)

- 5.0V CMOS logic level output
- Output voltage Low: 0.35Vdc (Max.), High: 4.5Vdc (Min.)
- Timing signal inside the camera can be output. Please set the signal to output by LineSource of DigitalIOControl.

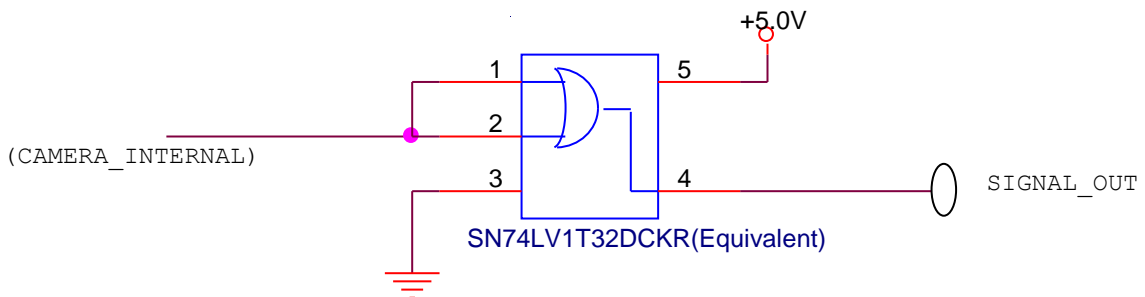

3.3. External Connector Pin Assignment

3.3.1 6pins Circular Connector

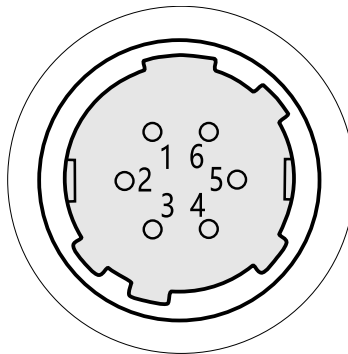

HR10-7R-6PA (HIROSE) or equivalent

Pin No.	Signals	Description
1	NC	
2	NC	
3	SIGNAL_OUT	Exposure/FVAL/LVAL/LinkTrigger can be selected to output
4	NC	
5	TRIGGER_IN	Trigger input
6	GND	Conduction with camera module

※NC=Non-Connection. Do not connect anything to the terminal.

3.3.2 75ΩBNC Connector

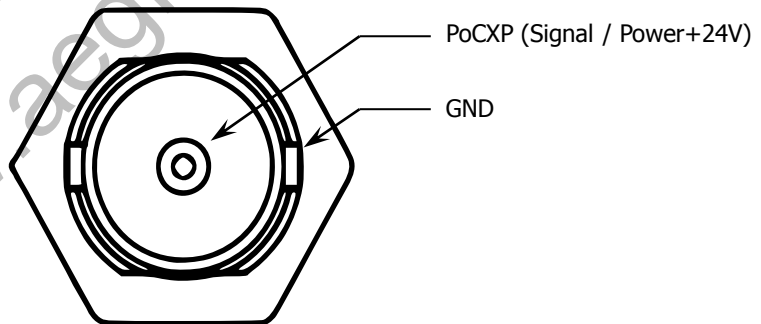

(BNC0V104C00 Japan Aviation Electronics Industry)

3.3.3 LED Indicator

- When the LED indicator is set to Active, lighting patterns of LED shows the camera status by the way of its lighting.

OFF	No Power supplied
Green lighting	Confirmed connection of the device and the host.
Green fast blinking [12.5Hz]	Transmitting video data.
Orange slow blinking [1Hz]	Waiting for the trigger input.
Red fast blinking [12.5Hz]	System error occurred.

### 3.4. Spectral Response

※ The lens characteristics, IR cut filter characteristics, and the illuminant characteristics are excluded.

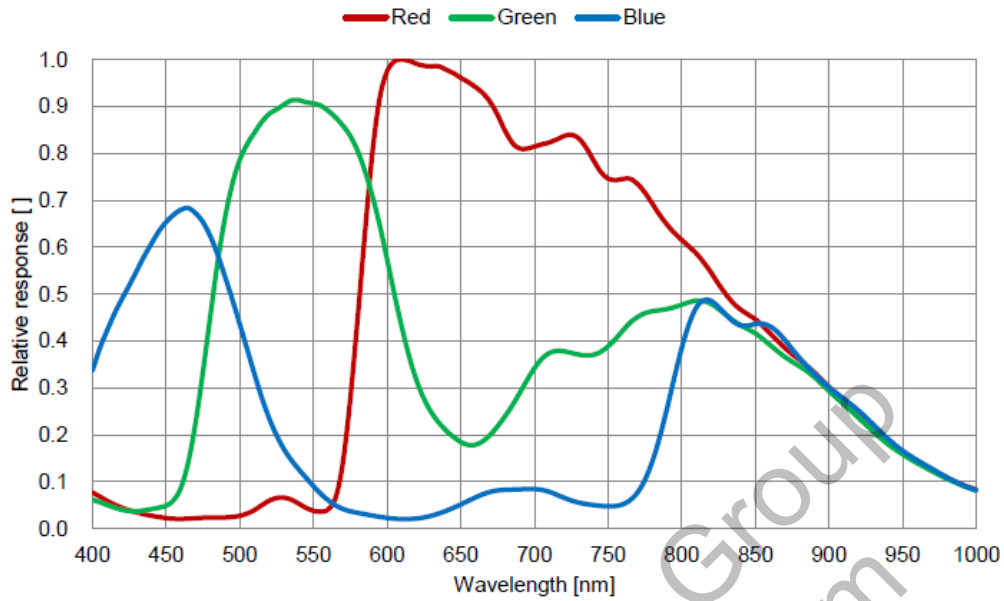

Aegis Electronic Group  
www.aegiselect.com

### 3.5. Output Timing

#### 3.5.1 Horizontal Sync. Timing

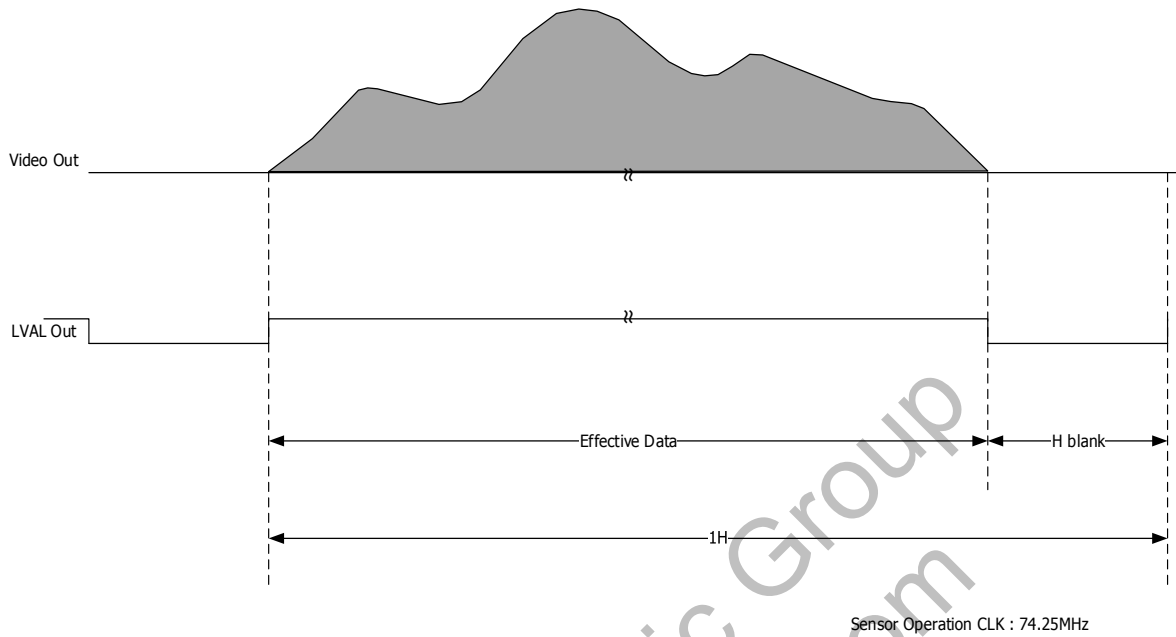

- ※The time for 1H shall be changed depends on the video output format.
- ※The blanking pixel number for 1H shall be changed depends on the video output format.

Effective pixel numbers and blanking pixel numbers

Video output format	Effective data / 4ch	H blank / 4ch	1H total pixel number / 4ch	Time for 1H [us]
BayerRG8/Mono8	180	62	242	3.26
BayerRG10/Mono10	180	52	232	3.91
BayerRG12/Mono12	180	84	264	5.33

Sensor Operation CLK = 74.25MHz

3.5.2 Vertical Sync. Timing

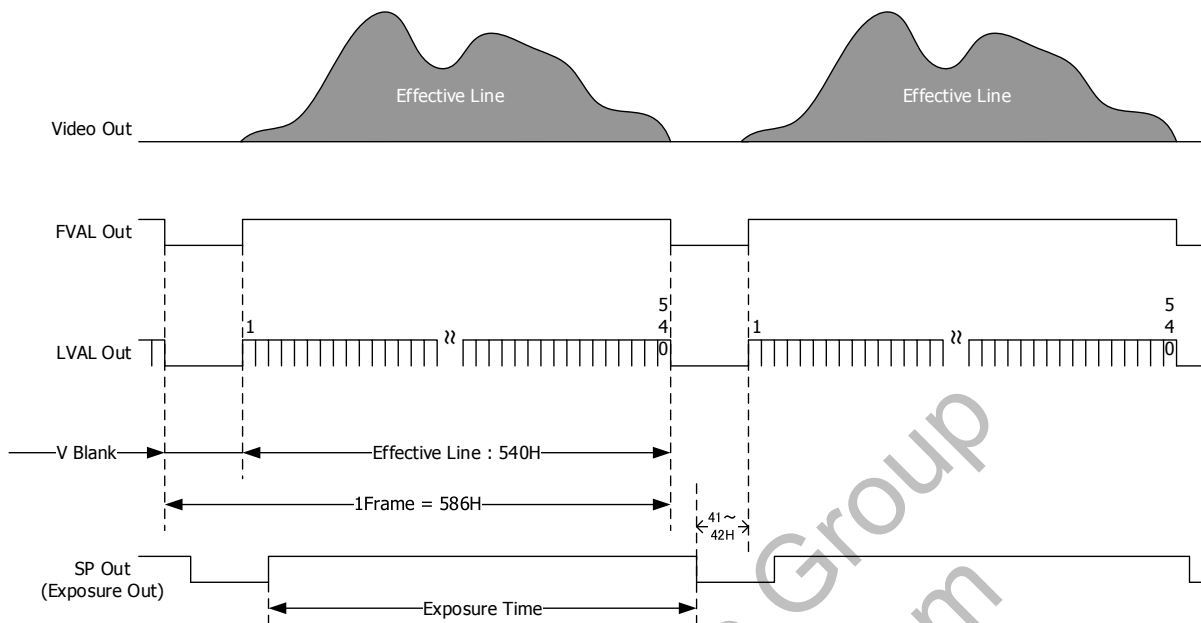

※The time for 1 frame shall be changed depends on the video output format.

Effective line numbers and blanking line numbers

Video output format	Effective line	V blank	1 frame total line number	Time for 1 frame [ms]
BayerRG8/Mono8	540	46	586	1.91
BayerRG10/Mono10	540	46	586	2.29
BayerRG12/Mono12	540	46	586	3.13

Sensor Operation CLK = 74.25MHz

#### 4. Camera Function

##### 4.1. Setting

- Conform to CoaXPress.

##### 4.2. How to Save and Initialize the Settings

UserSetControl	
UserSetSelector	Default UserSet0
UserSetLoad	Execute
UserSetSave	Execute

- If you wish to save the setting values in operation, execute "UserSetSave" by selecting UserSet0 (User save area) of UserSetSelector. Doing so, the setting values shall be saved in the camera non-volatile memory.
- Since Default (Factory settings) is a defined value, it cannot be saved.
  - The value of UserSetSelector cannot be saved by UserSetSave. It shall always be Default when the camera is powered up. Please set the values again when executing UserSetLoad / UserSetSave.
- Default (Factory settings) or UserSet0 (User save area) selected by UserSetSelector can be loaded by UserSetLoad.
- ※Please do not execute UserSetLoad when grabbing (acquiring image).
- Defective pixels correction value and UserID are to be saved when UserSetLoad of Default is executed.
- Even executing UserSetLoad, PixelFormat, ReverseX, and ReverseY shall maintain the settings of when executing. Please set again the values by command.

UserSetSelector	Default	UserSetLoad >Excute	= Initialize(Factory setting)
	UserSet0	UserSetLoad >Excute UserSetSave >Excute	= Initialize(User setting) = User setting Save

##### 4.3. Link Speed and Link Count

TransferControl	
ConnectionConfig	CXP3_X1

- CXP3\_X1 : Link speed=3.125Gbps, Link count=1

## 4.4. Pixel Format

- When changing mode, please also change the board settings as well.

ImageFormatControl	
PixelFormat	MONO8 MONO10 MONO12 BayerRG8 BayerRG10 BayerRG12

- MONO8 : Monochrome 8bit
- MONO10 : Monochrome 10bit
- MONO12 : Monochrome 12bit
- BayerRG8 : Bayer 8bit
- BayerRG10 : Bayer 10bit
- BayerRG12 : Bayer 12bit

※ Please do not change PixelFormat while grabbing (acquiring image).

## 4.5. Flip

ImageFormatControl	
ReverseX	True/False
ReverseY	True/False

- ReverseX : Flip the image of X direction
- ReverseY : Flip the image of Y direction

※ Please do not change flip setting while grabbing (acquiring image).

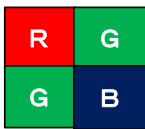

Bayer Pattern : RGGB

※With RAW model, Bayer pattern also flips when X or Y direction image flipping is set.

According to that change, RG, GR, GB, and BG for grabber board settings will be also changed.

## 4.6. Internal Sync. Mode (Free Run Mode)

- This is the mode to use triggers continuously made in the camera. No external trigger is used.
- Set TriggerMode to Off, and set TriggerSelector to AcquisitionStart.
- Frame rate (fps) when ROI is invalid are as follows.

PixelFormat	Frame Rate[fps]
BayerRG8/Mono8	523
BayerRG10/Mono10	437
BayerRG12/Mono12	320

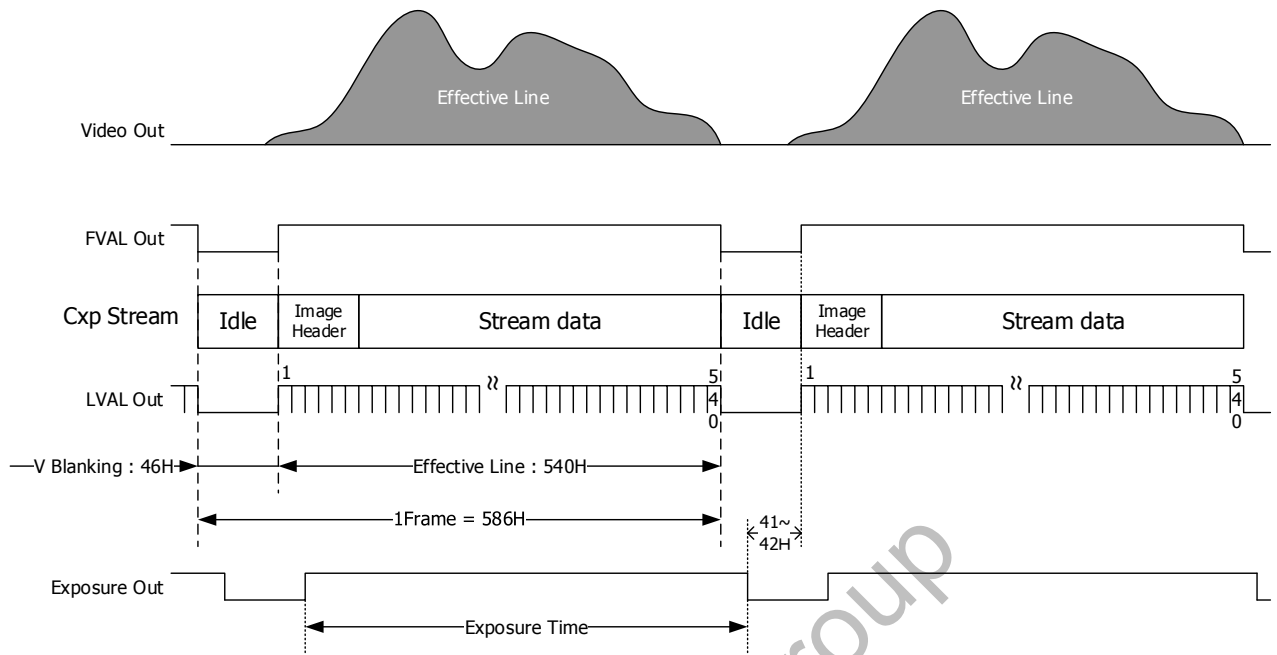

Vertical sync. timing (at free run) TriggerMode=Off

#### 4.7. External Trigger Sync. Mode

- This is a mode to input external trigger signals to capture images by any preferred timings.

AcquisitionControl	
TriggerMode	On/Off
TriggerSyncMode	LineSync ClockSync
TriggerSelector	AcquisitionStart FrameStart
TriggerActivation	RisingEdge FallingEdge LevelHigh LevelLow
TriggerSource	Software LinkTrigger0 Line0
TriggerSoftware	Execute

- **TriggerMode** : Trigger mode (Link with TriggerSelector)
  - Off : Free run mode (TriggerSelector = AcquisitionStart)
  - On : External trigger mode (TriggerSelector = FrameStart)

※Please do not change TriggerMode while grabbing (acquiring image).
  
- **TriggerSelector** : Trigger selector (Link with TriggerMode)
  - AcquisitionStart : Free run mode (TriggerMode = Off)
  - FrameStart : External trigger mode (TriggerMode = On)

※Please do not change TriggerSelector while grabbing (acquiring image).
  
- **TriggerSyncMode** : Trigger sync. mode
  - LineSync : H sync. trigger mode (Exposure time is controllable per line)
    - Fixed/Pulse width trigger shutter mode
    - Overlapping operation (Exposure while reading out image) is valid.
  
  - ClockSync : CLK sync. trigger mode (Exposure time is controllable per sensor clock)
    - FAST fixed/FAST pulse width trigger shutter mode
    - Overlapping operation (Exposure while reading out image) is invalid.

※Please change TriggerSyncMode when there is no trigger input.  
 ※Please set LineSync mode beforehand to return to free run mode.
  
- **TriggerSource** : trigger source (This is to select where to input the external trigger.)
  - LinkTrigger0 : External trigger input from CoaXPress Host Device
    - Please refer to the product specifications & operational manual of the Host Device (ex. grabber board) to know how to generate the trigger.
  - Line0 : Input the external trigger via 6pins circular connector.
  - Software : TriggerSoftware

※Please make sure TriggerMode is turned ON before setting.
  
- **TriggerSoftware** : Software
 

A trigger is generated in the camera and capture images for 1 frame when this command is executed.  
 ※Please make sure to set TriggerSource to Software.
  
- **TriggerActivation** : Trigger activation
 

This is to select how to start capturing image and polarity out of followings.

  - RisingEdge : Fixed trigger shutter mode: Rising edge (Timed)
  - FallingEdge : Fixed trigger shutter mode: Falling edge (Timed)
  - LevelHigh : Pulse width trigger shutter mode: High active (TriggerWidth)
  - LevelLow : Pulse width trigger shutter mode: Low active (TriggerWidth)

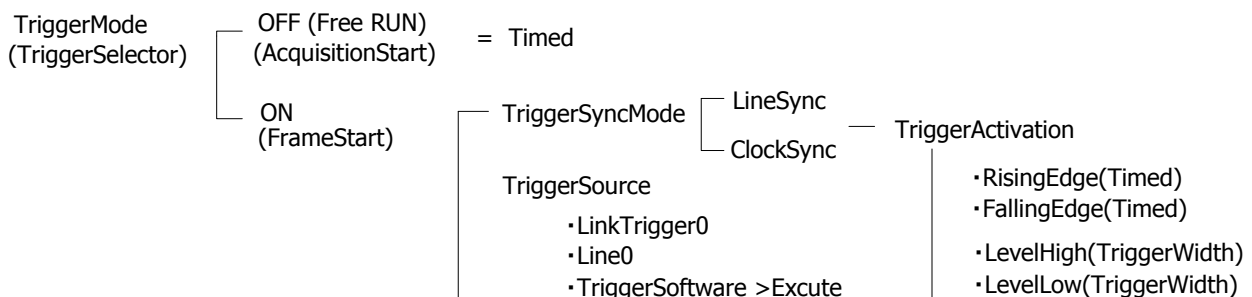

4.8. Trigger Sync. Mode and Delay Time to Start Exposure

- H sync. trigger mode (LineSync): 1H of jitter may occur from inputting trigger to exposure. (Overlapping operation is valid.)
- CLK sync. trigger mode (ClockSync): Less delay time from trigger input, and the precise trigger operation is valid. (Overlapping operation is invalid.)

Exposure delay time for each mode	CXP3_X1
Delay time to start exposure at H sync. trigger (LineSync)	Approx. 2H~3H
Delay time to start exposure at CLK sync. trigger (ClockSync)	Approx. 0.05us

4.9. Restrictions on Trigger Pulse Input Timing

- The next trigger pulse can be input while reading out signals (Readout). However, please do not input a trigger pulse which ends its exposure while reading out the prior signals. In other words, a trigger pulse, while reading out signals for the prior frame and starts reading out signals for the next frame, cannot be input.

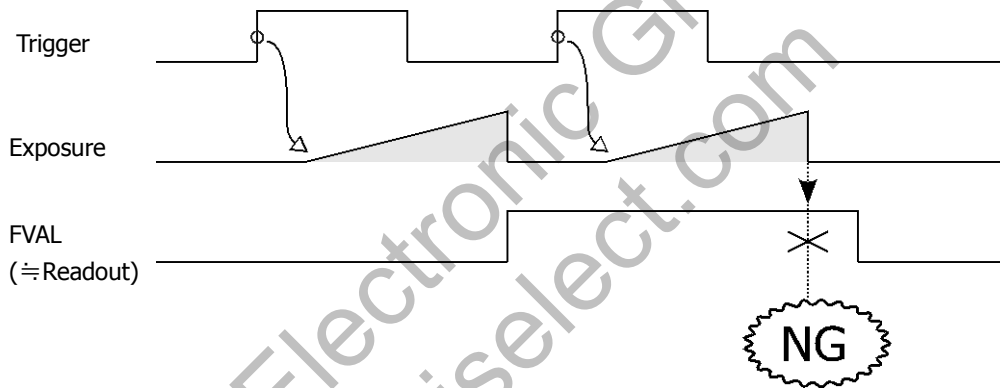

- When a trigger is input with the restricted timing explained the above, "IllegalTriggerFlag" becomes "1".

AcquisitionControl	
IllegalTriggerFlag	0 or 1

Since overlapping operation is invalid at CLK sync. mode, the trigger at this timing shall be masked and "IllegalTriggerFlag" will not become "1".

DeviceControl	
ErrorFlagReset	Execute

This is to reset IllegalTriggerFlag to "0".

4.10. Fixed Trigger Shutter Mode (LineSync.) H Sync. Trigger

(TriggerMode=On, TriggerSyncMode=LineSync, TriggerActivation=RisingEdge)

- This is the mode to start exposure with external input trigger signals, and execute exposure for set period.
- Trigger operation is H sync., V sync. reset system.
- The delay time (Exposure Time Delay) from detecting the trigger edge in the camera to actually starting exposure is 2H~3H. 1H jitter would occur to Exposure Time Delay since the external trigger signal shall synchronize with H inside the camera. The trigger pulse with the minimum 1H or more shall be input (Please refer to the Time for 1H in the table in [Section 3.5.1](#)).
- There is an exposure time period for approx. **14.26μs** at the edge right after exposure time.

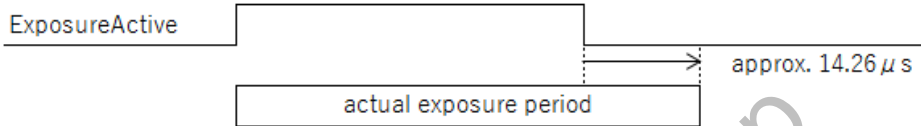

- The next trigger while outputting video for the prior trigger can be accepted. However, do not input a trigger signal to start the next video outputting before completion of outputting the prior images.
  - Trigger input while exposure period (Exposure Time) shall be ignored in the camera. ((A) in the drawing below)
- Please note that a trigger shorter than 1 frame shall not be used.

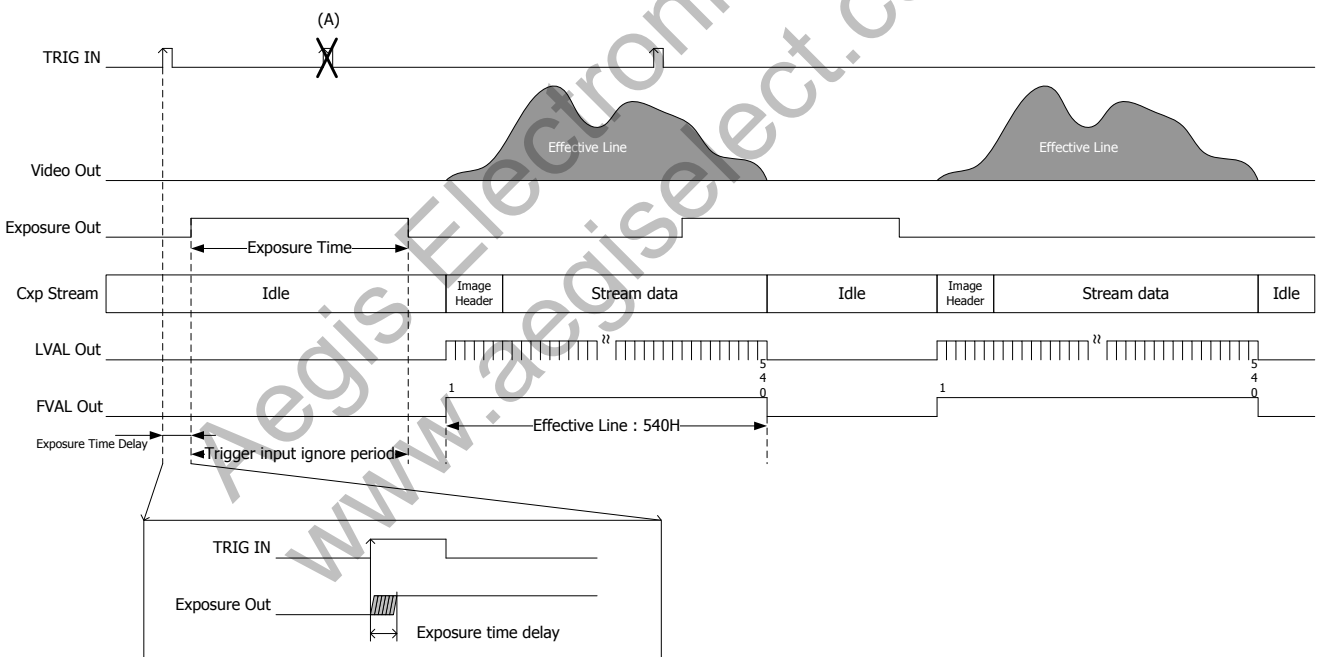

4.11. FAST Fixed Trigger Shutter Mode (ClockSync.) CLK Sync. Trigger

(TriggerMode=On, TriggerSyncMode=ClockSync, TriggerActivation= RisingEdge)

- This is the mode to start exposure with external input trigger signals, and execute exposure for set period.
- Trigger operation is CLK sync., V sync. reset system.
- The delay time (Exposure Time Delay) from detecting the trigger edge in the camera to actually starting exposure is approx. **0.05μs**. Please input 1μs or more of pulse to the trigger.
- There is an exposure time period for approx. **14.26μs** at the edge right after exposure time.

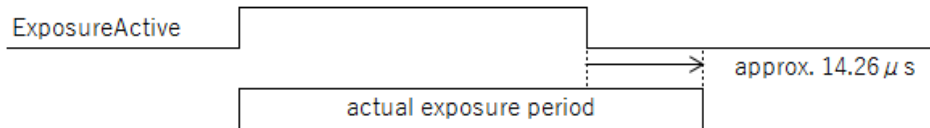

- The next trigger while outputting video for the prior trigger cannot be accepted. Trigger input while exposure period and reading out period shall be ignored in the camera. (Refer to (A) and (B) in the drawing below.)

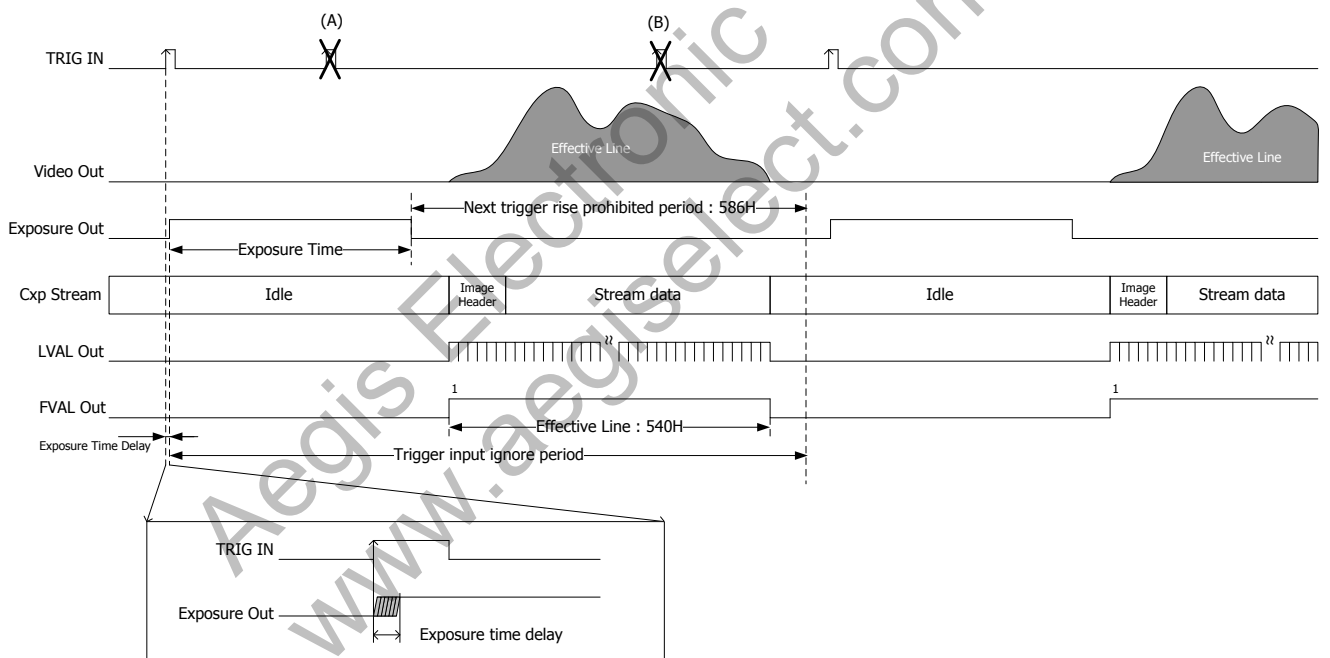

4.12. Pulse Width Trigger Shutter Mode (LineSync.) H Sync. Trigger

(TriggerMode=On, TriggerSyncMode=LineSync, TriggerActivation=LevelHigh)

- This is the mode to start exposure with external input trigger signals, and set the exposure time with pulse width of the trigger signals.
- Trigger operation is H sync., V sync. reset system.

The delay time (Exposure Time Delay①) from detecting trigger edge in the camera to starting ExposureActive is 2H~3H. The delay time (Exposure Time Delay②) from detecting trigger edge in the camera to end ExposureActive is 2H~3H.

- Since the external trigger signals synchronize with camera internal H cycle, approx. 1H jitter occurs to Exposure Time Delay ① and ②. In case of pulse width trigger mode, jitters may occur at both start and end edges of exposure. At this time, exposure time would change so that flicker might be noticeable in the image, especially when high-speed shutter is set. This flicker sometimes can be eliminated when fixed trigger shutter mode is used. However, this problem can be solved by inputting a trigger pulse with synchronizing it to the camera internal H cycle (LVAL).
- Pulse width 1H (Min.) ~ Approx. 2 frames  
Functionally, there is no upper limitation, but dark noises, shadings, and noises may be noticeable at long time exposure.
- There is an exposure time period for approx. **14.26μs** at the edge right after exposure time.

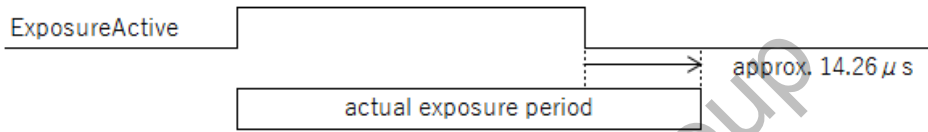

- Trigger input during exposure time shall be ignored in the camera. However, a trigger shorter than 1 frame cycle should not be used.
- Triggers can be accepted while outputting video output images. However, please be noted that a trigger signal to start the next video outputting should not be input before completion of outputting the prior images. (Please refer to (A) in the drawing below).

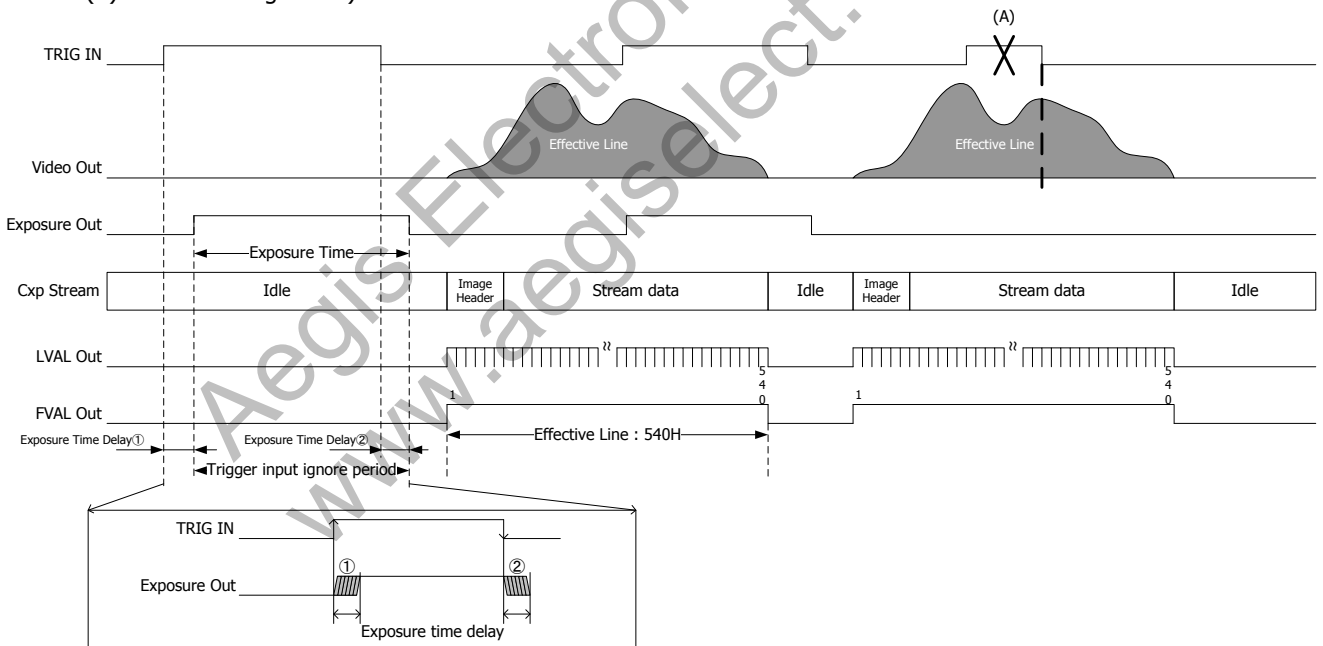

4.13. FAST Pulse Width Trigger Shutter Mode (ClockSync.) CLK Sync. Trigger

(TriggerMode=On, TriggerSyncMode=ClockSync, TriggerActivation=LevelHigh)

□ This is the mode to start exposure by the external input trigger signals. Exposure time is the set time with the width of the trigger signal.

□ Trigger operation is CLK sync., V sync. reset system.

The delay time (Exposure Time Delay①) from detecting the trigger edge in the camera to starting ExposureActive is

approx. **0.05μs**.

□ Pulse width **0.74μs** (Min.) ~ approx. 2 frame

Functionally, there is no upper limitation, but dark noises, shadings, and noises may be noticeable at long time exposure.

□ There is an exposure time period for approx. **14.26μs** at the edge right after exposure time.

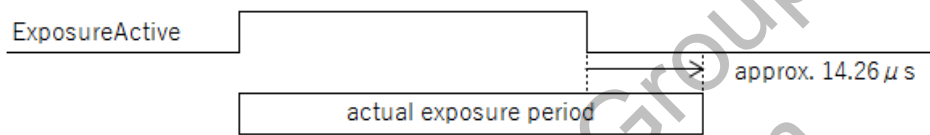

□ Trigger input during reading out period shall be ignored in the camera. (Please refer to (A) in the drawing below)

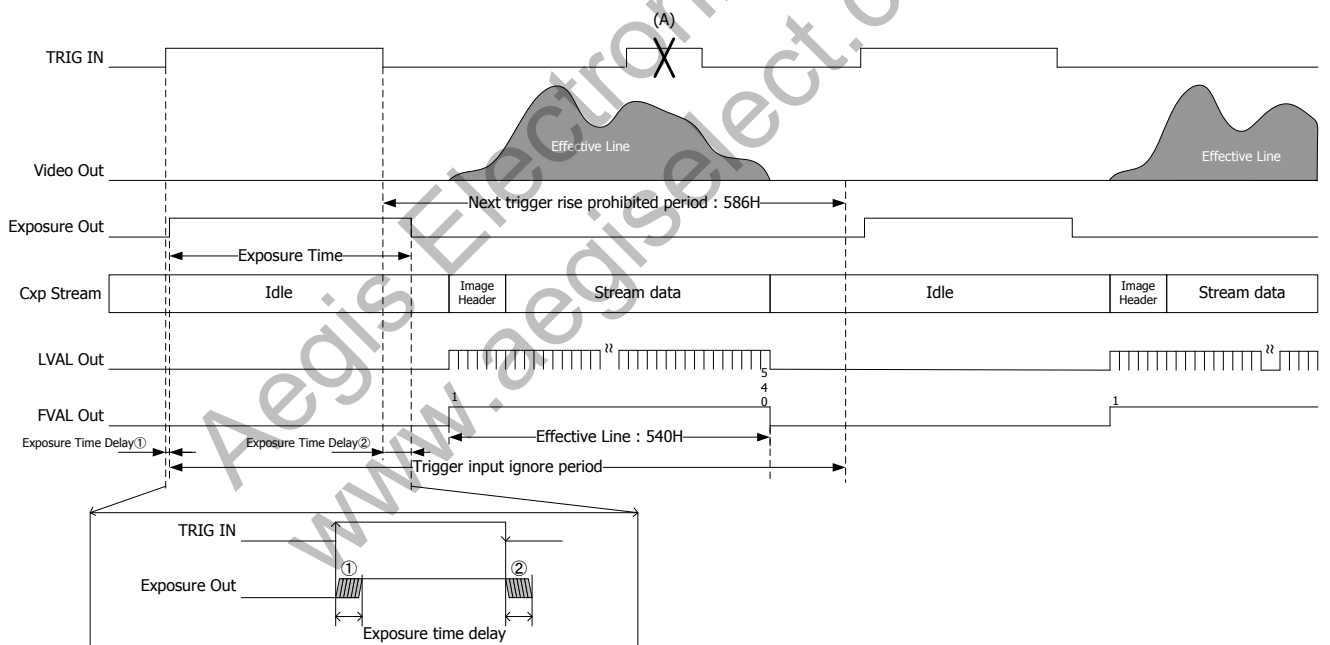

## 4.14. Exposure Time

AcquisitionControl	
ExposureMode	Timed TriggerWidth
ExposureTime (us)	15us~Max. Exposure time
ExposureTimeMax	(ReadOnly)

ExposureMode : This is to check if the current mode is at Timed or TriggerWidth (PWC).

ExposureTime : Exposure time (Valid when ExposureMode is at Timed)

- Please set per 1H at H sync. trigger. It shall return the value (us) rounded by 1H per Min. 1H mode.
- It can be set per approx. 1us at CLK sync. trigger.

ExposureTimeMax : The maximum exposure time

- Please set the smaller value than ExposureTimeMax at internal sync. mode.
- It shall depends on partial scan (ROI) settings and "PixelFormat".
- The maximum of H sync. trigger mode (LineSync.) shall be clipped with effective line count.
- CLK sync. mode (ClockSync.) can be set from 15us~200ms. It shall not be clipped with effective line count.

## 4.15. Formula to Calculate Manual Shutter Values with H Sync Mode

The values shall be corrected correspond to the formula below.

Formula: Exposure time = Time for 1 line (Please refer to the Time for 1H in the table in [Section 3.5.1](#)) × Exposure line count + **14.26μs**

※The Min. setting value shall be clipped with 1, and the Max. setting value shall be clipped with 540 or the total line count at partial.

## 4.16. Manual Shutter Settings with CLK Sync. Mode (FAST Trigger Mode)

- Min. setting value: **15μs** (Approximate value)
- Max. setting value: **200ms** (Approximate value)
  - ※ Unlike H sync. mode, clipping shall not be executed by total line count, etc.
  - ※ Bright point may be noticeable at long time exposure.
- Setting unit: 1μs (Approximate value)
  - ※ Slight differences may occur since it is generated by 74.25MHz clock.
- Exposure time = Setting value

## 4.17. Gain

AnalogControl	
Gain	Manual

- Gain : x1.00 to x256.00 preferred Gain can be set.

Functionally, up to 256 times of the value can be set. However, image degradation cannot be avoided when high gain is set. We recommend you to evaluate it first.

## 4.18. Gamma Correction

- This is to execute gamma correction.

AnalogControl	
Gamma	Settings for the coefficient of 0.10~1.80.

- Gamma : This is to set the gamma correction value per 0.01step.

[Note] Gamma table shall be updated at image output timing. It shall be applied at image output after the completion of rewriting the gamma table (Approx. 20ms: Command ACK is the rough standard.) at continuous operation mode. In case the gamma coefficient is changed while waiting trigger to be input, the gamma updated image shall be output with the trigger after the completion of rewriting the table.

## 4.19. Sensor Black Level Adjustment

- This is to adjust black level of the sensor.

AnalogControl	
BlackOffset	-64~63

[Note] This function is not the function to set the absolute value of black level.

This function can change the black level settings of the image sensor relatively. The value is converted into 12bit. In case of 10bit, the value shall be equivalent to  $\pm 16$ , and in case of 8bit, the value shall be equivalent to  $\pm 4$ .

Please set x4 of signal level in case of 10bit image, and set x16 of signal level in case of 8bit image. Settings can be changed while capturing images. However, image may be distorted.

## 4.20. Partial Scan (ROI)

- This is to increase its frame rate by cutting out and reducing the read out area vertically.
- It shall be Idle output in case the RegionMode of Region 1 is OFF.

ImageFormatControl	
RegionSelector	EffectiveRegion , Region1
RegionMode	On/Off
RegionDestination	Stream0
Width	720 (Fixed)
Height	4~540 (Multiples of 4)
OffsetX	0 (Fixed)
OffsetY	0~536 (Multiples of 4)

- RegionSelector : This is to select the region to be set.  
Partial area can be set with Region1.  
Please select EffectiveRegion to output image.
- RegionMode : This is to set valid/invalid of Region1.  
※This function cannot be turned ON in case Width, Height, OffsetX, and OffsetY are not set to effective settings.
- RegionDestination : This is to select the Stream to be output. This model VCC-VCXP5R is fixed to Stream0.

- Width : This is to set the width of Region. The model VCC-VCXP5R is fixed to 720.
  - Height : This is to set the height of Region.
    - ※Please make sure that the Height setting does not exceed the maximum height correspond to OffsetY setting.
  - OffsetX: This is to set the Offset settings for X direction of the Region. This model VCC-VCXP5R is set to 0.
  - OffsetY: This is to set the Offset settings for Y direction of the Region.
    - ※Please make sure not to exceed the maximum height correspond to Height setting.
- Total line count per frame = V blanking lines + Effective partial line numbers  
Please note that sum total of partial effective line numbers (except V blanking lines) has to be less than 540.  
V blanking lines at partial mode is 46H.
- Frame rate =  $1 / (\text{Total frame line count} \times \text{Time for 1 line})$   
Time for 1 line: Please refer to the Time for 1H in the table in [Section 3.5.1](#).
- The line numbers at partial scan setting can be set from 4 lines. Only multiple numbers of 4 can be set.
  - The effective line numbers of the manual shutter setting value at partial scan setting become the maximum (except at Clk sync. trigger).
  - When you switch between Full Frame Scan Mode and Partial Scan Mode or when you change Partial scan settings, the first one frame right after the changes shall be invalid.  
\*Especially at fixed trigger shutter mode and pulse width trigger shutter mode, input a dummy Trigger first, and use the next trigger as an actual video signal.

#### 4.21. Defective Pixels Correction

- This is the function to detect and correct the pixel defects in the data output from the sensor.
- Data are categorized into two types and controlled.
  - Data at Ex-Factory  
The detected data of white pixel defects and black pixel defects at Ex-Factory are saved. Basically, these data cannot be erased.
  - Data registered by users  
Data increased after shipment or the one registered by users.  
These data can be entirely erased anytime by DefectPixelDefault.  
Data shall not be initialized by UserSetDefault.
- Defective pixels correction information are saved separately at normal and at vertical flip.  
(The position and the number of defective pixels are different at normal and at vertical flip.)
- The number of data registerable by users is 64 points. (Note: Up to 16 points per CH.)

[CH (Channel)] Images are processed by 4CH interleave in the camera.

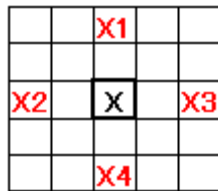
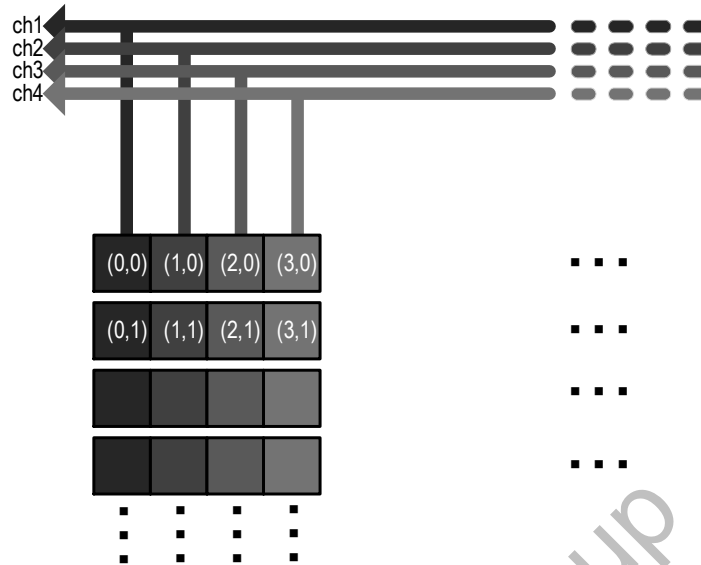

※In case of color model

The value for X pixel is calculated referring to the same color pixel next to the next. When X1, X2, X3, and X4 were already registered as defected pixels, X can be added to be registered but it cannot be corrected.

□ Defective pixels correction control

This is to select ON/OFF of defective pixels correction processing.

Data at Ex-factory and data registered by users are both controlled at the same time.

AnalogControl	
DefectPixelCorrection	ON/OFF
DefectPixelAdd	(Execute)
DefectPixelAddOffsetY	0~539
DefectPixelAddOffsetX	0~719
DefectPixelDelete	(Execute)

□ Add the specified X and Y coordinate of defective pixels registered by user

Any preferred pixels can be registered and deleted as defective pixels by specifying coordinate.

- DefectPixelCorrection: This is to select valid/invalid of defective pixels correction.
- DefectPixelAddOffsetY: This is to specify Y coordinate.
- DefectPixelAddOffsetX: This is to specify X coordinate.
- Please execute DefectPixelAdd to register the specified coordinate as a defective pixel correction point.
- Please execute DefectPixelDelete to delete the specified coordinate as a defective pixel correction point.

- ※ In case the coordinate same as the defective data at ex-factory is specified, it shall be ignored.
- ※ Only the added defects by DefectPixelAdd or DefectDetection can be deleted. Data at ex-factory cannot be deleted by this command.

□ Defective Pixels Detection Registered by Users

This is to detect and register the correction data of white defect caused by the image sensor.

<b>AnalogControl</b>	
DefectDetectionThresholdValue	0~4095
DefectDetection	(Execute)
DefectDetectionStatus	(ReadOnly)
DefectPixelDefault	(Execute)
DefectCorrectMode	Reacquire/Add

- DefectDetectionThresholdValue : This is to set the threshold value (0~4095: 12bit equivalent) of defective pixels detection registered by user.  
4 times more value of the image signal level shall be specified as the threshold value with 10bit images, and 16 times more value of the image signal level shall be specified as the threshold value with 8bit images.
- DefectDetection: This is to detect the defective pixels registered by user.  
This is the function to register the pixels automatically if a pixel exceeds the level specified at DefectDetectionThresholdValue. Please be noted that no lights should be in the sensor surface to use this function.  
  
The defective pixels correction registered by user shall be reflected right after the execution. In case UserSetSave is executed after defective pixels detection registered by users, the data will be saved in non-volatile memory.
- DefectDetectionStatus: This is to indicate the result of the defective pixels detection registered by users.

0	None defective pixels correction data registered by users.
Value (64 or less)	Detected number of defective pixels registered by users.
0x000e0001 (917505)	Defective pixels correction data exceeds the maximum number (16 points) registerable in one CH.
0x000e0002 (917506)	Defective pixels correction data exceeds the maximum number (64 points) registerable. ※Error indication may be shown in decimal depends on the frame grabber to be used.

If 65 points or more is indicated, please check the threshold value (DefectDetectionThesholdValue) of defective pixels detection registered by user is appropriate, and please also check the indication of defective pixels (DefectivePixelCorrection).

- DefectPixelDefault : This is to delete entire defective pixels correction data registered by users.
- DefectCorrectMode: This is to set the detection mode of defective pixels.  
In case Reacquire is selected, other than defective pixel added by one point addition shall be deleted, and reacquire the defective point again.  
In case Add is selected, the defect point is additionally acquired for the current defect point.

[Note]

- Correction data shall be acquired only when the camera is in operation. When camera is not outputting anything, white defect detection cannot be performed.
- When detecting user registered defects, custom ROI mode shall be OFF. (Size shall be set to 720x540.)

- When changing the threshold value of DefectDetectionThresholdValue and acquiring the defective pixels correction data registered by user, please execute DefectPixelDefault and delete the defective pixels correction data registered by user to reacquire it.
- The registerable number of pixel defects and the correctable number of pixel defects may not be always the same because of the following reasons.
  - (1) With white defects detection, if one of the strip reed reached the maximum number, correction could not be performed. In such case, the data up to that point are registered, error is output, and operation ends.
  - (2) If no effective pixels exist up next, down next, right next, or left next to the pixel to be corrected, this pixel can be registered but cannot be corrected.

□ Defective Pixels Indication

This is to indicate the coordinate of defect registered by users.

AnalogControl	
RegisteredDefectSelector	UserState/InitialState
DefectPixelNumber	1~64/1~192
DefectPixelOffsetY	(ReadOnly)
DefectPixelOffsetX	(ReadOnly)
DefectPixelType	(ReadOnly)

- RegisteredDefectSelector : This is to select the type of registered defect.
- DefectPixelNumber : This is to set the number to the registered defect.  
The table number of the defect data at ex-factory and the defect registered by users shall be specified.
- DefectPixelOffsetY : This is to indicate the Y coordinate of the defect specified at DefectPixelNumber.  
65535 shall be indicated for the number of the table which does not have any defect data.
- DefectPixelOffsetX : This is to indicate the X coordinate of the defect specified at DefectPixelNumber.  
65535 shall be indicated for the number of the table which does not have any defect data.
- DefectPixelType : This is to indicate the defect type specified at DefectPixelNumber.
  - 1: White defect at ex-factory
  - 2: Black defect at ex-factory
  - 6: Defect registered by user
  - 7: Defect additionally registered by user
  - 65535: The table which does not have defect data

AnalogControl	
ChannelNumber	1~4
DefectPixelChannelCount	(ReadOnly)

- ChannelNumber : This is to specify the channel number of defect processing.
- DefectPixelChannelCount : This is to indicate the number of defects of channel number specified at ChannelNumber. The specified number of the defect of the channel number is the sum total of the defects at ex-factory and the number of defects registered by user.

## 4.22. Test Pattern Indication

- Test pattern can be output from the camera. It is useful to check if your system is operating properly.

ImageFormatControl	
TestPattern	Off ColorBar

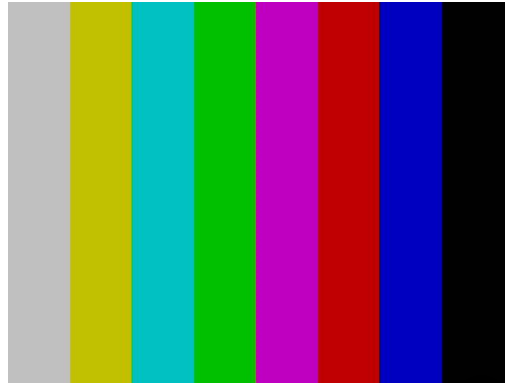

※ This function cannot be set when cursor indication is ON.

## 4.23. Cursor Indication

- This is to indicate the cursor on the screen.

ImageFormatControl	
CursorPattern	Off/On
CursorOffsetX	X coordinate
CursorOffsetY	Y coordinate
CursorColor	White/Black

※ This function cannot be set when test pattern indication is ON.

- CursorPattern : Specify if the cursor shall be indicated or not.
- CursorOffsetX : This is to specify the X coordinate of vertical cursor.
- CursorOffsetY : This is to specify the Y coordinate of horizontal cursor.
- CursorColor : This is to specify the color of the cursor. (White/Black)

## [Note]

- ♦ The origin, (0,0) of the cursor coordinate is the upper left at partial (ROI) indication.
- ♦ The cursor may not be shown on the screen when the indicated image is scaled down.

## 4.24. LED Operational Mode

- This is to change the operation of LED on the camera rear. Please refer [LED Indicator](#) for the lighting patterns.

DeviceControl	
DeviceIndicatorMode	Active ErrorStatus Inactive

- Active : This is to indicate the communication status of CoaXPress.
- ErrorStatus : Lights OFF at normal status. Lights only when there was a system error.
- Inactive : ALL LED OFF.

## 4.25. Camera Timing Output

- The signals below can be output from 3pin of 6pins circular connector by LineSource settings.

DigitalIOControl	
LineSelector	Line0
LineMode	Output
LineSource	OFF ExposureActive FrameActive LineActive TriggerPacketActive

- LineSource : This is to select the output signal.
- ExposureActive : This is to indicate exposure period of image sensor by Hi Active.
- FrameActive : This is to indicate effective period of frame by Hi Active. (FVAL)
- LineActive : This is to indicate effective period of line by Hi Active. (LVAL)
- TriggerPacketActive : This is to output uplink trigger packet signal from frame grabber by decoding. (LinkTrigger)

## 4.26. User ID Save

DeviceControl	
DeviceUserID	Manual

- This is the function to set data with up to 16 letters. (Including NUL character ( )) By executing "UserSetSave", data shall be saved in the non-volatile memory. This item shall maintain the set value even execute "UserSetLoad" at "Default".

## 4.27. Temperature Indication

- This is to indicate the temperature register value of the image sensor. (Indicated by  C)

DeviceControl	
DeviceTemperature	ReadOnly

[Note]

- This value shall not be calibrated. Please regard this value as a reference value.

## 4.28. White Balance

AnalogControl	
BalanceRatioSelector	Red Blue
BalanceWhiteAuto	Off Once
BalanceRatio	0.00~8.00

- BalanceWhiteAuto : This is to adjust white balance gain automatically.

Off : Standing-by

Once : Automatically adjust white balance with one push.

Select "Once" of BalanceWhiteAuto to adjust white balance automatically and return to OFF.

New gain for the selected color component by BalanceRatioSelector is indicated to BalanceRatio.

Shoot an achromatic object to the full screen to execute. We recommend approx. 50% of signal level to execute.

※"Once" of BalanceWhiteAuto shall be executed with RegionSelector is set to EffectiveRegion.

The following commands are valid only when BalanceWhiteAuto is OFF.

- BalanceRatioSelector : This is to select the color component to be changed with BalanceRatio.
- BalanceRatio : This is to set gain in the range of 0 ~ 8 times.

White balance becomes invalid when BalanceRatioSelector is set to Red, BalanceRatio to 1.0, BalanceRatioSelector to Blue, and BalanceRatio to 1.0.

## 5. Factory Settings

Function	Data	Description
TriggerSelector	AcquisitionStart	Equivalent to TriggerMode=Off
TriggerMode	Off	Link to TriggerSelector
TriggerSyncMode	LineSync	Horizontal sync. mode
TriggerSource	LinkTrigger0	CXP UPLink trigger
TriggerActivation	RisingEdge	Rising edge
ExposureTime	1774.0	1774us
Gain	1.00	x1.00
Gamma	1.00	Gamma coefficient=1.00
DefectPixelCorrection	On	Defective pixels correction On
DefectPixelAddOffsetX	0	This is to specify X coordinate.
DefectPixelAddOffsetY	0	This is to specify Y coordinate.
DefectDetectionThesholdValue	200	Defective pixels detection threshold value (Indicate only Guru level)
BlackOffset	0	Black level initial value
PixelFormat	BayerRG8	RAW model
ConnectionConfig	CXP3_X1	CxpLinkConfiguration
TestMode	NomalOperation	Use at Link test OFF
RegionSelector	EffectiveRegion	This is to specify the number of Partial area (ROI) (Region1)
RegionMode	On	Partial area (ROI) On/Off
Height	540	This is to specify the height of partial area (ROI).
OffsetY	0	This is to specify the start position of Partial area (ROI).
ReverseX	False	Horizontal flip OFF
ReverseY	False	Vertical flip OFF
TestPattern	Off	Cursor indication and Test pattern cannot be ON at the same time.
CursorPattern	Off	Test pattern and Cursor pattern cannot be ON at the same time.
CursorOffsetX	360	This is to specify the cursor position X
CursorOffsetY	270	This is to specify the cursor position Y
CursorColor	White	Cursor color White/Black
DeviceIndicatorMode	Active	Indicate LED indicator
LineSource	Off	Circular 6P-3pin output settings
DeviceUserID		User letter string setting (16 letters)

※ PixelFormat, ReverseX, and ReverseY are not subject to UserSetLoad operation.

6. Dimensions

6.1. Camera Dimensions

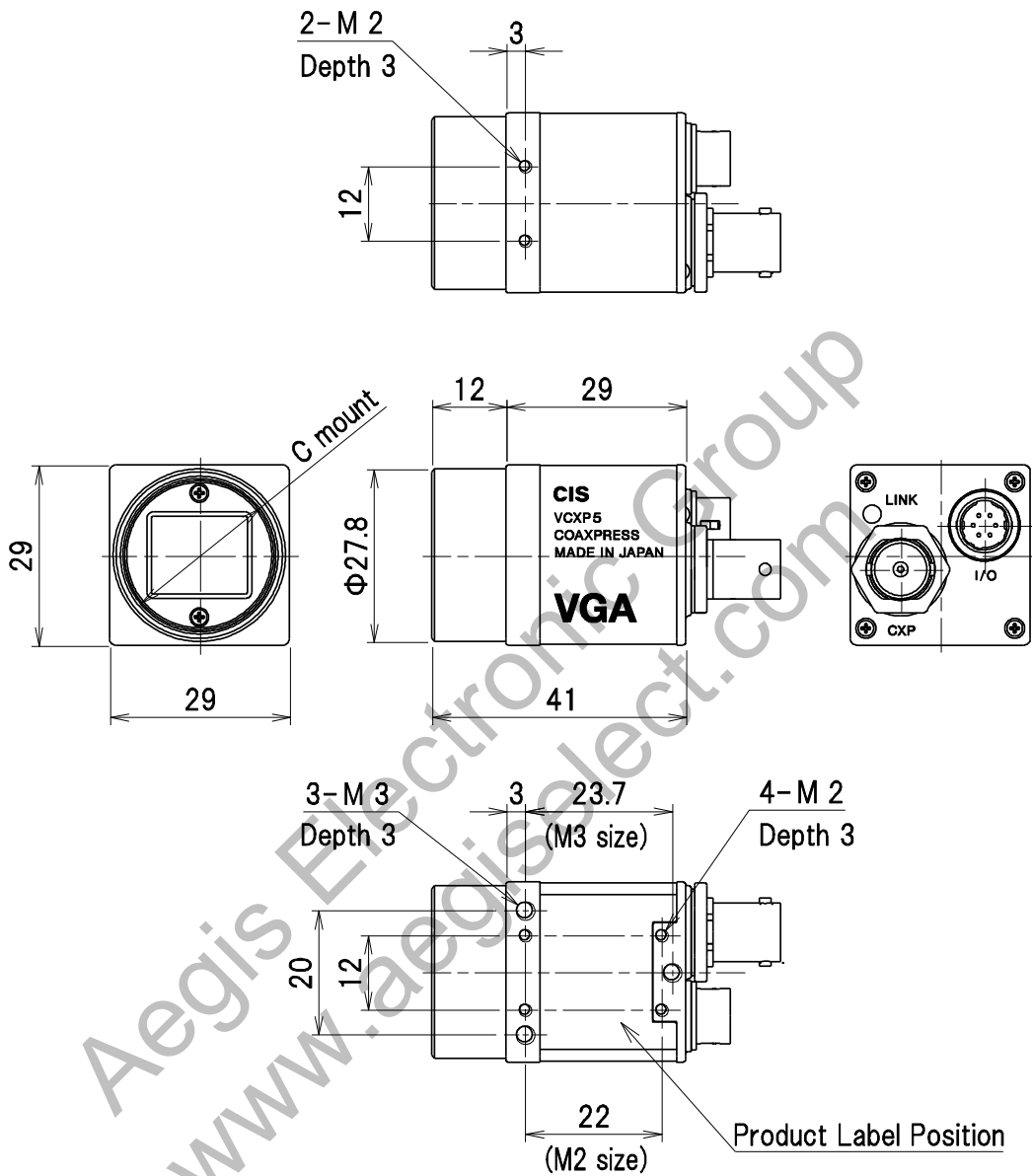

- 2) C mount screws comply with ANSI/ASME B1.1, 1-32UN(2B).
- 1) Screw length from the lens mount surface shall be less than 6mm.  
And protruding portion of the C mount lens shall be less than 10mm.

935-0142-00  
(Unit:mm)

6.2. Optical Axis Accuracy

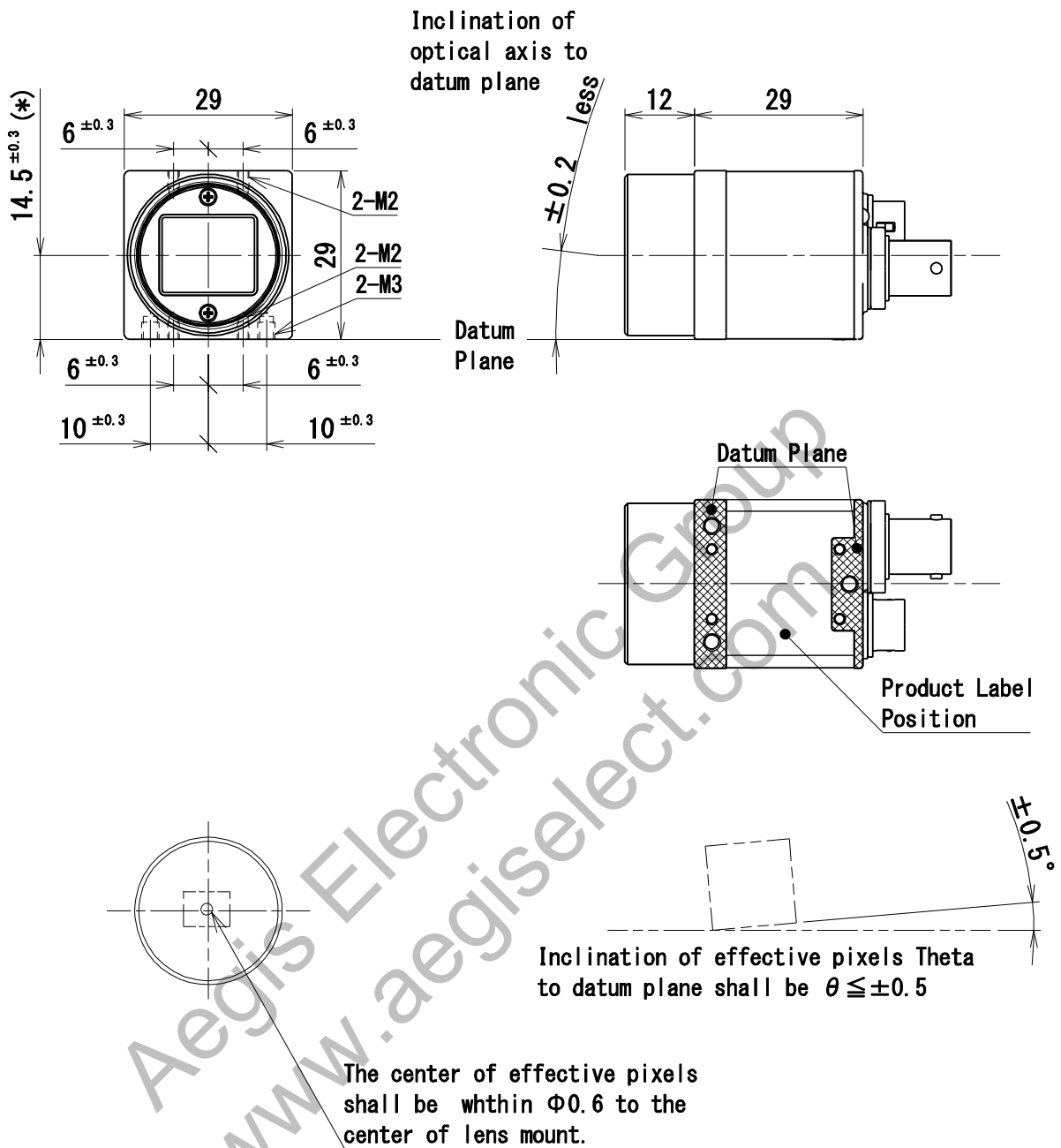

(\*)Dimension from datum plane to the center of lens mount.

937-0014-00  
(Unit:mm)

## 7. Case for Indemnity

### 7.1. Product Warranty

The term of warranty of this product is within 3 years from the date of shipping out from our factory.

If you use the product properly and discover a defect during the warranty period, and if that was caused by designing or manufacturing, CIS Corporation, at its option, repairs or replaces it at no charge to you. Products out of warranty period will be subject to charge. CIS repairs the products as long as it is repairable.

CIS shall be exempted from taking responsibility and held harmless for damages or losses incurred by the following cases.

- In case damages or losses are caused by earthquake, lightning strike, fire, flood, or other acts of God.
- In case damages or losses are caused by deliberate or accidental misuse by the user, or failure to observe the information contained in the instructions in this Product Specification and Operational Manual.
- In case damages or losses are caused by repair or modification conducted by the customer or any unauthorized party.

### 7.2. CMOS Pixel Defect

CIS compensates the noticeable CMOS pixel defects found at the shipping inspection prior to our shipment. On very rare occasions, however, CMOS pixel defects might be noted with time of usage of the products. Cause of the CMOS pixel defect is the characteristic phenomenon of CMOS sensor itself and CIS is exempted from taking any responsibilities for them. Should you have any questions on CMOS pixel defects compensation please contact us.

### 7.3. Product Support

Should you have any problems in function of the product you purchased, and if you need our further analysis and/or repair, please contact the dealer you purchased it from.