

CIS

English

**GigE Vision I/F
CMOS B/W Camera**

VCC/DCC-VCP1GEM

**Product Specifications
& Operational Manual**

CIS Corporation

Table of Contents

	PAGE
1. Handling Precautions	3
2. Product Outline	4
3. System Configuration	4
3.1. Standard Bundled Items	4
3.2. Packaging	4
4. Specifications	5
4.1. General Specifications	5
4.2. CMOS Sensor Spectral Response	6
5. External Connector Pin Assignment	7
5.1. 6pins Connector SNH-8-6 (SamWoo) or Equivalent for VCC-VCP1GEM	7
5.2. 6pins Connector 53398-0671 (MOLEX) or Equivalent for DCC-VCP1GEM	7
5.3. IP Configuration Initialization Function	7
6. Camera Operation by Viewer Software	8
6.1. Activation of Viewer Software	8
6.2. Details on Function Settings	9
6.2.1. Device Control	9
6.2.2. Image Format Control	9
6.2.3. Acquisition Control	10
6.2.4. Analog Control	10
6.2.5. User Set Control	10
6.2.6. Transport Layer Control – GigE Vision	11
7. Camera Dimensions	12
7.1. Dimensions of VCC-VCP1GEM	12
7.2. Dimensions of DCC-VCP1GEM	13
8. Case for Indemnity (Limited Warranty)	14
9. CMOS Pixel Defect	14
10. Product Support	14
11. List of the Initial Setting Values for Each Parameter	15

1. Handling Precautions

The camera must not be used for any nuclear equipments or aerospace equipments with which mechanical failure or malfunction could result in serious bodily injury or loss of human life. Our warranty does not apply to damages or defects caused by irregular and/or abnormal use of the product.

Please observe all warnings and cautions stated below.

Our warranty does not apply to damages or malfunctions caused by neglecting these precautions.

- Do not use or store the camera in the extremely dusty or humid places.
- Do not apply excessive force or static electricity that could damage the camera.
- Do not shoot direct images that are extremely bright (e.g., light source, sun, etc.), and when camera is not in use, put the lens cap on.
- Follow the instructions in Chapter 5, "External connector pin assignment" for connecting the camera. Improper connection may cause damages not only to the camera but also to the connected devices.
- Confirm the mutual ground potential carefully before connecting the camera to monitors or computers. Any AC leaks from the connected devices may cause damages or destroy the camera.
- Do not apply excessive voltage. (Use only the specified voltage.) Unstable or improper power supply voltage may cause damages or malfunction of the camera.
- The voltage ripple of camera power DC $+12V \pm 10\%$ shall be within $\pm 50mV$. Improper power supply voltage may cause noises on the video signals.
- The rising time of camera power supply voltage shall be less than $+10V$, Max 60ms. Please avoid noises like chattering when rising.

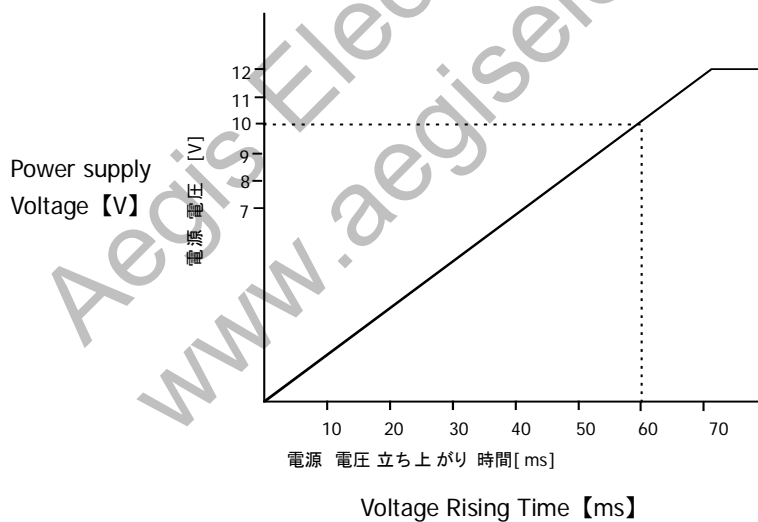

2. Product Outline

VCC-VCP1GEM and DCC-VCP1GEM are GigE Vision I/F output B/W camera modules utilizing a 1/4 type, WVGA (752x480) pixels CMOS sensor. VCC-VCP1GEM is a cased type camera and DCC-VCP1GEM is a camera without casing. The camera can be directly connected to a Desktop PC or a Note PC with GigE connector equipped. No need to prepare for an interface card for these PCs. Easy to setup and cost effective.

Features

For both VCC-VCP1GEM and DCC-VCP1GEM

- Global shutter type CMOS sensor (B/W)
- GigE Vision I/F
- AE, Shutter control, Gain control function ready

For VCC-VCP1GEM

- Camera Chassis
- C lens mount

For DCC-VCP1GEM

- M14 lens mount

3. System Configuration

3.1. Standard Bundled Items

- Camera, VCC/DCC-VCP1GEM
- Lens mount cap (attached to the camera)

3.2. Packaging

- Individual carton
- Master carton (TBD pcs/carton)

Note) Master carton may vary depends on the quantity to be shipped.

4. Specifications

4.1. General Specifications

(1) Pickup device	Device Type	1/4 type global shutter type CMOS		
	Effective Pixel Numbers	752(H) × 480(V)		
	Unit Cell Size	4.5μm(H) x 4.5μm(V)		
	Chip Size	8.50mm(H) x 8.50mm(V)		
(2) Video output format	32(H) x 32(V)~752(H) x 480(V), 30~120fps			
(3) Resolution	752(H) x 480(V)			
(4) Video output	Sensor AD	10bit		
(5) Sensitivity	F8 400lx (Shutter speed 1/30s, Gain 0dB)			
(6) Minimum illumination	1.3 lx Lens Aperture: F1.4 Exposure time: 1/30s Gain Max: +18dB Output level: 50%			
(7) Gain variable range	x1~x4 (0dB~12dB) [Guaranteed range], Up to x8 can be set manually. ※This is the gain value for image sensor output, but not for the final output.			
(8) Power requirements	DC+12V±10% (power supplied via 6pins connector) or PoE 48V (power supplied via Ether port).			
(9) Power consumption	2.5 W (at DC+12V IN)			
(10) Dimensions	•VCC-VCP1GEM:H:47mm W:47mm D:34mm (without protruding part) •DCC-VCP1GEM:H:42mm W:42mm D:11.6mm (without protruding part)			
(11) Weight	•VCC-VCP1GEM:125g •DCC-VCP1GEM: 36g			
(12) Lens Mount	•VCC-VCP1GEM:C mount •DCC-VCP1GEM: M14 mount			
(13) Shutter speed variable range	Manual : 99.18[s] ~ 33332.8[s] ※ The longest value of Shutter speed (exposure time) depends on its video format.			
(14) Safety/Quality standards	UL: Conform to UL Standard including materials and others. Conform to EMC.(2014/30/EU)			
	CE:	EN61000-6-4:2007+A1:2011 for Emission (※DCC-VCP1GEM conform this only with PoE power supply). EN61000-6-2:2005 for Immunity		
	RoHS:	Conform to RoHS (2011/65/EU),EN50581(RoHS2)		
(15) Durability	Vibration	Acceleration	98m/s ² (10G)	
		Frequency	20~500 Hz (1Sweep 15min)	
		Direction	X,Y, and Z, 3 directions	
		Testing time	120 min for each direction	
	Shock	No malfunction shall be occurred with 980m/s ² (100G) for ±X,±Y, and ±Z, 6 directions.		
(16) Operation environment ※1	Performance guaranteed	0 ~ +45°C	Humidity 20 ~ 80%RH	with no condensation
	Operation guaranteed	-5 ~ +50°C	Humidity 20 ~ 80%RH	with no condensation
	※Performance guaranteed: All the specifications specified in this manual is guaranteed under performance guaranteed temperature.			
	※Operation guaranteed: All the camera functions operate normally under operation guaranteed temperature. ※Heat dissipation measure shall be well considered and taken for DCC-VCP1GEM.			
(17) Storage Environment	Storage Temperature: -25 ~ +60°C, Humidity: 20 ~ 80% RH with no condensation.			

※1. When ambient temperature is high, more defective pixels could be noticeable.

※ Strong light from the right side of the image, such as strong backlight, may cause vertical black stripe-shaped noises.

4.2. CMOS Sensor Spectral Response

※The lens characteristic and the illuminant characteristics are excluded.

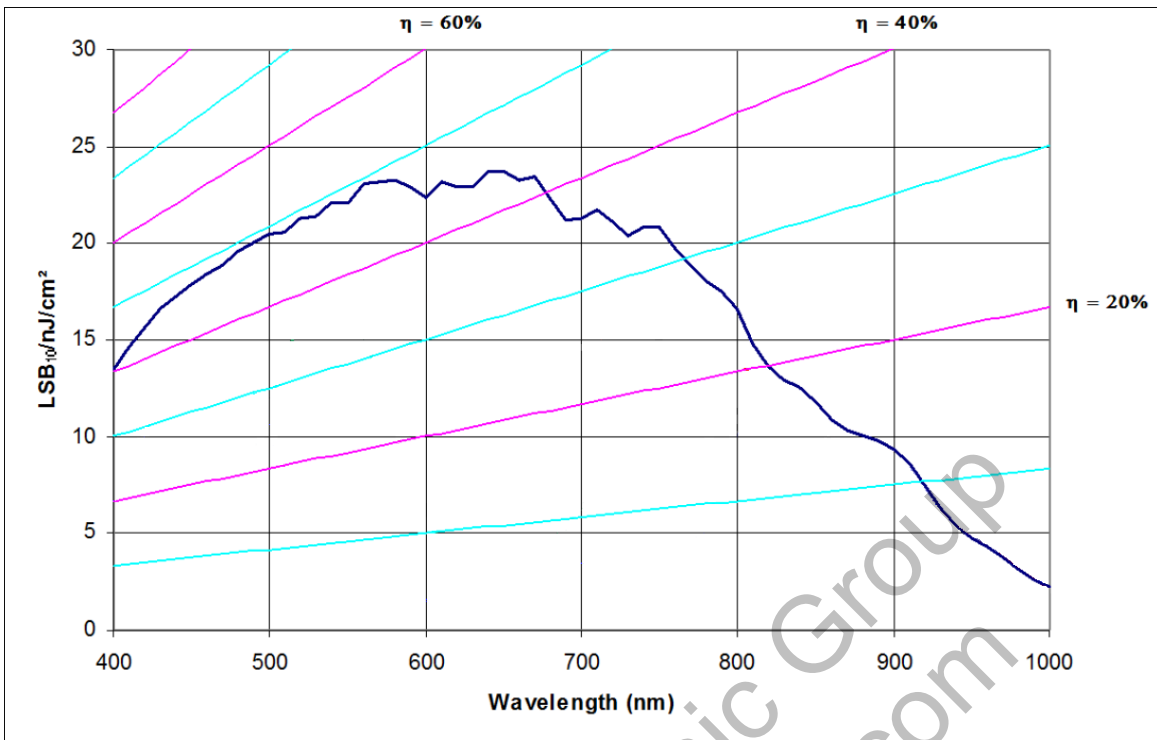

5. External Connector Pin Assignment

5.1. 6pins Connector SNH-8-6 (SamWoo) or Equivalent for VCC-VCP1GEM

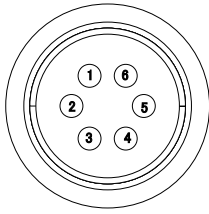

Pin No.	Signal Name	Description
1	Power IN	Power Input (DC 12V typical)
2	NC	Not used
3	IP Config Def	Initialization of IP Configuration
4	NC	Not used
5	NC	Not used
6	GND	GND for DC12V

※

※ NC=Non-Connection. Do not connect anything to the terminal.

5.2. 6pins Connector 53398-0671 (MOLEX) or Equivalent for DCC-VCP1GEM

Pin No.	Signal Name	Description
1	NC	Not used
2	NC	Not used
3	IP Config Def	Initialization of IP Configuration
4	NC	Not used
5	NC	Not used
6	GND	GND

※ NC=Non-Connection. Do not connect anything to the terminal.

5.3. IP Configuration Initialization Function

Short circuit of the 6pins circular connector Pin No. 3 and GND first, then turn on power to restore the settings of IP configuration.

- GevCurrentIPConfigurationDHCP = True
- GevCurrentIPConfigurationPersistentIP = False

6. Camera Operation by Viewer Software

6.1. Activation of Viewer Software

Supply power to the camera.

Activate SPHINX GEV Viewer on your PC and the following screen shall be shown.

Click DISCOVERY to show Discovery screen.

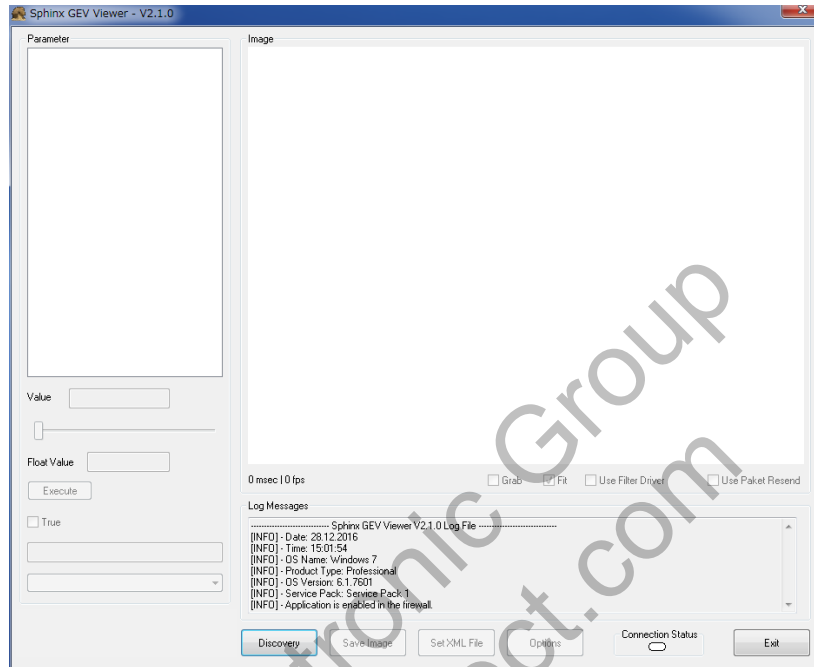

Confirm that the appropriate model appears on the Discovered Devices.

Once you confirmed it, click OPEN.

※If the appropriate model does not appear, change your network setting to 1Gbps communication.
(Speeds other than 1Gbps cannot be connected).

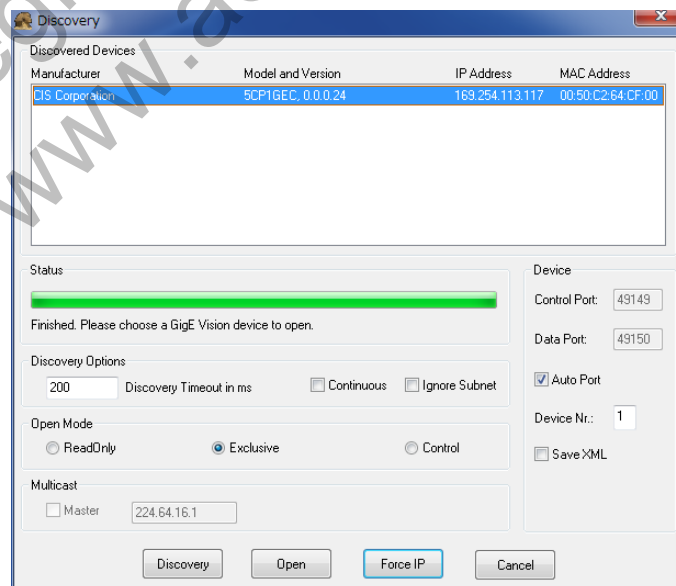

Function and Setting items shall be shown in the Parameter part in SPHINX GEV Viewer.
 Check Grab to start capturing images.

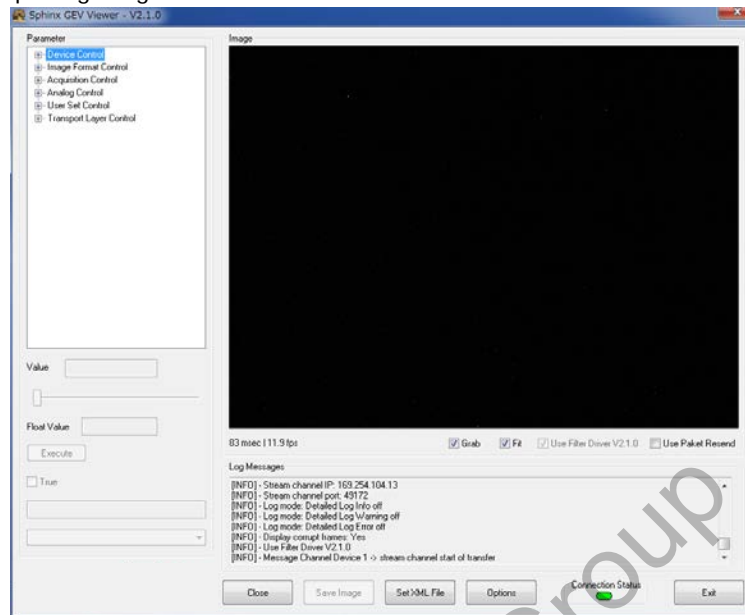

6.2. Details on Function Settings

Refer to the Section 11. List of the Initial setting values for each parameter

6.2.1. Device Control

Name	Access	Contents
DeviceVendorName	RO	CIS Corporation.
DeviceModelName	RO	VCP1GEM
DeviceManufactureInfo	RO	GigE Vision Camera
DeviceVersion	RO	Returns its device version.
DeviceSerialNumber	RO	Returns its serial number.
DeviceUserID	RW	Set a preferred User ID. ※It will be written immediately.
DeviceScanType	RO	Fixed Area scan
DeviceSFNCVersionMajor	RO	Returns its SFNC version of GenICam XML.
DeviceSFNCVersionMinor	RO	
DeviceSFNCVersionSubMinor	RO	

6.2.2. Image Format Control

Name	Access	Contents
WidthMax	RO	The maximum image width: 752max
HeightMax	RO	The maximum image height: 480max
Width	RW	The minimum image width:32, the maximum:752, Step:1
Height	RW	The minimum image height:32, the maximum:480, Step:1
OffsetX	RW	Horizontal direction Offset The maximum value: WidthMax - Width = OffsetX
OffsetY	RW	Vertical direction Offset The maximum value: HeightMax - Height = OffsetY
PixelFormat	RW	Mono 8 Mono 10
TestPattern	RW	Off Grey Horizontal Ramp, Gray Vertical Ramp

6.2.3. Acquisition Control

Name	Access	Contents
AcquisitionMode	RW	Continuous (Mode to capture images continuously) fixed
AcquisitionStart	RW	Start capturing data
AcquisitionStop	RW	Stop capturing data
AcquisitionFrameRate	RW	Set its frame rate. 30Hz(30fps)~120Hz(120fps)
TriggerSelector	RO	Frame Start fixed
TriggerSource	RO	Software fixed
TriggerMode	RW	Set camera trigger operation mode. Off = 0: trigger mode OFF On = 1: trigger mode ON
TriggerSoftware	WO	Execute software trigger.
ExposureMode	RO	Timed fixed
ExposureTime	RW	Set the exposure time per us for Manual operation. The longest value of exposure time depends on its frame rate.
ExposureAuto	RW	Off = 0: Set exposure manually. Continuous = 1: Set exposure automatically.

6.2.4. Analog Control

Name	Access	Contents
Gain	RW	Set gain with magnification ratio (x1 ~x 8) for Manual operation.
GainAuto	RW	Off = 0: Set Gain setting to Manual. Continuous = 1: Set Gain setting to Auto.
GammaMode	RW	Off = 0: Set Gain setting to OFF. On = Adjust gamma equivalent to ITU-709.

6.2.5 User Set Control

Name	Access	Contents
UserSetSelector	RW	Select user set bank. Default = 0: Bank to read out the factory setting. UserSet1 = 1: user set Bank 1
UserSetLoad	WO	Execute Loading of UserSetSelector
UserSetSave	WO	Execute user set Save (Cannot be saved as Default) The followings are the applicable parameters. Width Height OffsetX OffsetY PixelFormat AcquisitionFrameRate ExposureTime ExposureAuto Gain GainAuto

6.2.6 Transport Layer Control – GigE Vision

Name	Access	Contents
GevInterfaceSelector	RO	Responds its network interface.
GevMACAddress	RO	Returns its MAC address.
GevCurrentIPConfigurationLLA	RO	Returns the settings of LLA IP configuration.
GevCurrentIPConfigurationDHCP	RW	Switches settings of DHCP IP configuration.※
GevCurrentIPConfigurationPersistentIP	RW	Switches settings of Persistent IP configuration.※
GevCurrentIPAddress	RO	Returns the Current IP address.
GevCurrentSubnetMask	RO	Returns the Current subnet mask.
GevCurrentDefaultGateway	RO	Returns the Current default gate way.
GevPersistentIPAddress	RW	Set the Persistent IP address.※
GevPersistentSubnetMask	RW	Set the Persistent subnet mask.※
GevPersistentDefaultGateway	RW	Set the Persistent default gate way.※

※Written immediately and become valid after rebooting.

Aegis Electronic Group
www.aegiselect.com

7. Camera Dimensions

7.1. Dimensions of VCC-VCP1GEM

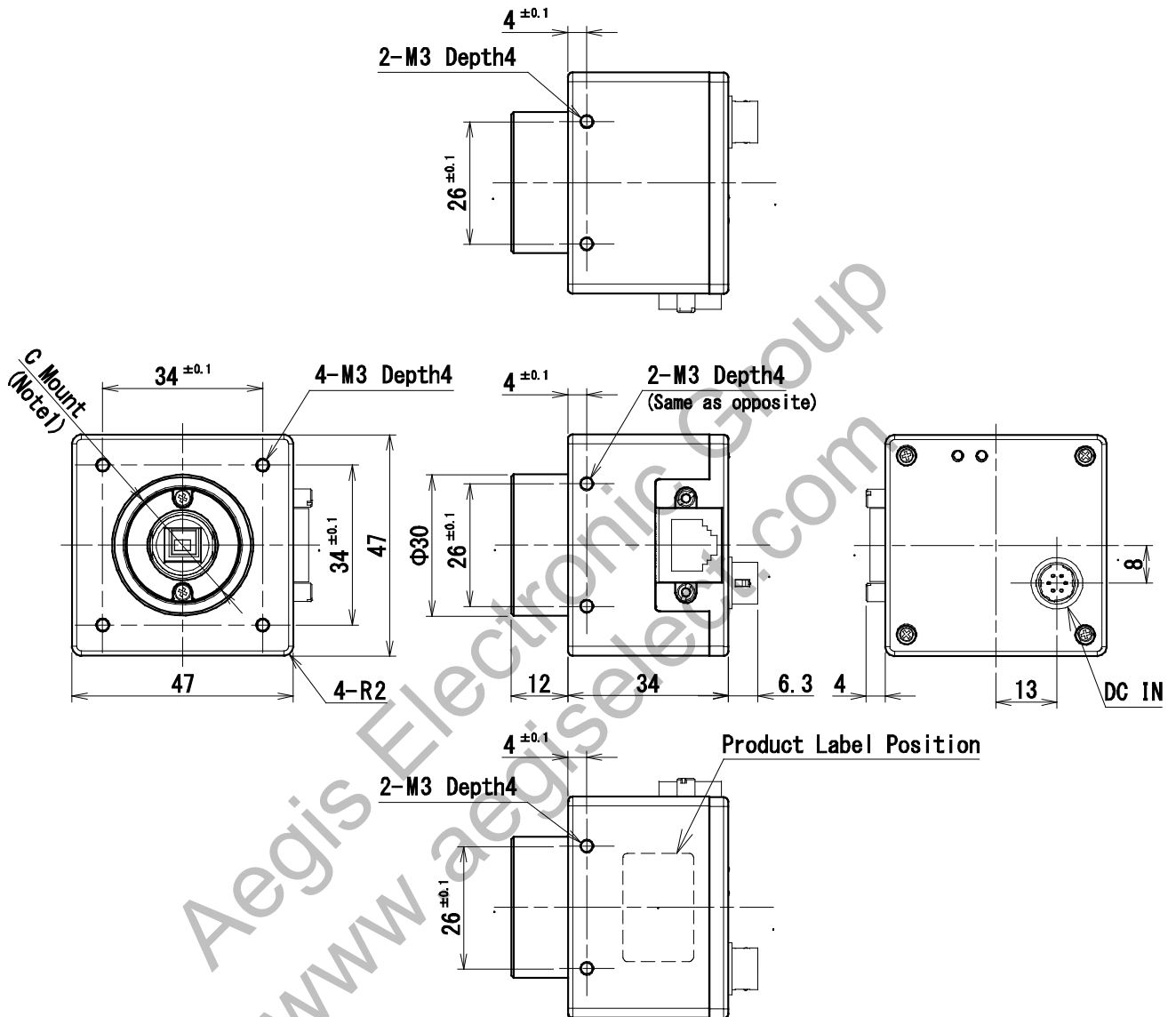

Note1) C Mount screws comply with ANSI/ASME B1.1, 1-32UN(2B).

Note2) Screw length from C Mount lens surface shall be under 6mm.

And, protruding portion shall be less than 10mm.

935-0059-00
(Unit:mm)

7.2. Dimensions of DCC-VCP1GEM

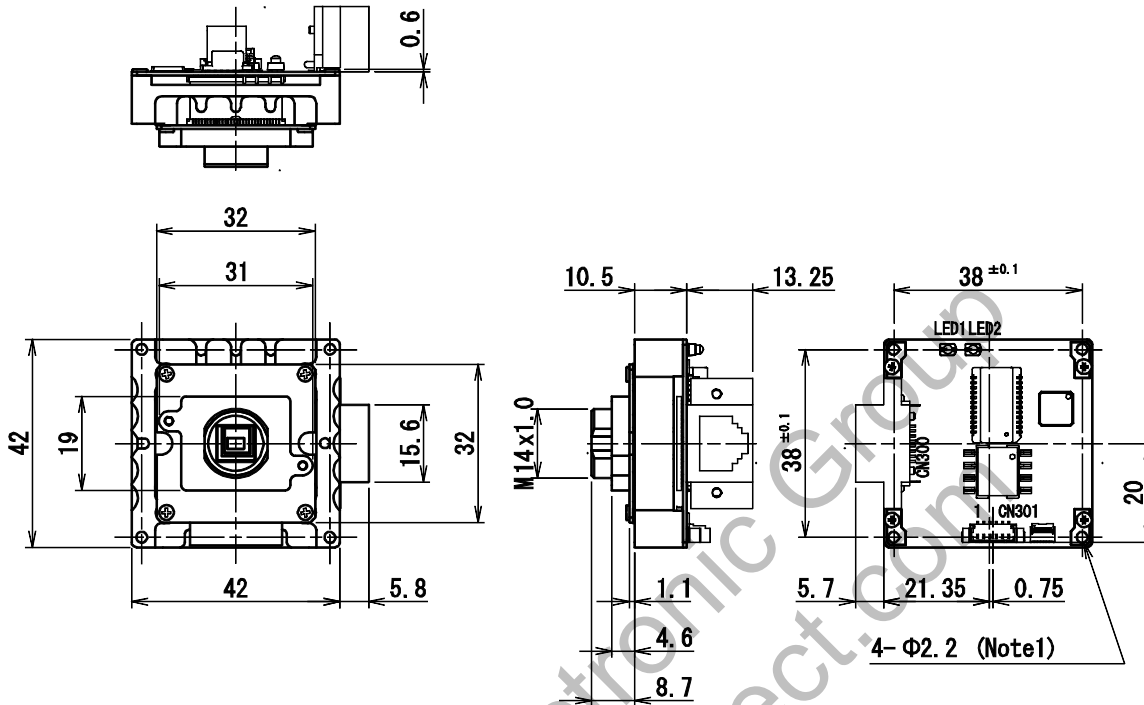

**Note1) External form of the fixing component shall be under $\phi 4$.
Otherwise, it would interfere and may damage the camera's component parts.**

935-0060-00
(Unit:mm)

8. Case for Indemnity (Limited Warranty)

The term of warranty of this product is within 1 year from the date of shipping out from our factory.

If you use the product properly and discover a defect during the warranty period, and if that was caused by designing or manufacturing, CIS Corporation, at its option, repairs or replaces it at no charge to you.

Products out of warranty period will be subject to charge. CIS repairs the products as long as it is repairable.

CIS shall be exempted from taking responsibility and held harmless for damages or losses incurred by the following cases.

- In case damages or losses are caused by earthquake, lightning strike, fire, or other acts of God.
- In case damages or losses are caused by deliberate or accidental misuse by the user, or failure to observe the information contained in the instructions in this Product Specification and Operational Manual.
- In case damages or losses are caused by repair or modification conducted by the customer or any unauthorized party.

9. CMOS Pixel Defect

CIS compensates the noticeable CMOS pixel defects found at the shipping inspection prior to our shipment. On very rare occasions, however, CMOS pixel defects might be noted with time of usage of the products. Cause of the CMOS pixel defect is the characteristic phenomenon of CMOS sensor itself and CIS is exempted from taking any responsibilities for them. Should you have any questions on CMOS pixel defects compensation please contact us.

10. Product Support

Should you have any problems in function of the product you purchased, and if you need our further analysis and/or repair, please contact the dealer you purchased it from.

11. List of the Initial Setting Values for Each Parameter

Category	Type	Name	DisplayName	Visibility	ImposedAccessMode	Length	VCP1GEM Defaults
DeviceControl	StringReq	DeviceVendorName	Device Vendor Name	Beginner	RO	32	"CIS Corporation"
	StringReq	DeviceModelName	Device Model Name	Beginner	RO	32	"VCP1GEM"
	StringReq	DeviceManufacturerInfo	Device Manufacturer Info	Beginner	RO	48	"GigE Vision Camera"
	StringReq	DeviceVersion	Device Version	Beginner	RO	32	Firm Version
	StringReq	DeviceSerialNumber	Device Serial Number	Expert	RO	16	Serial Number
	StringReq	DeviceUserID	Device User ID	Expert	RO	16	(Empty character string)
	Enumeration	DeviceScanType	Device Scan Type	Beginner	RO	2	Areascan (0)
	Integer	DeviceSFNCVersionMajor	Device SFNC Version Major	Beginner	RO	2	2
	Integer	DeviceSFNCVersionMinor	Device SFNC Version Minor	Beginner	RO	3	3
	Integer	DeviceSFNCVersionSubMinor	Device SFNC Version Sub Minor	Beginner	RO	0	0
	Enumeration	DeviceTLType	Device TL Type	Beginner	RO	0	GigEVision (0)
	Integer	DeviceTLVersionMajor	Device TL Version Major	Beginner	RO	1	1
	Integer	DeviceTLVersionMinor	Device TL Version Minor	Beginner	RO	2	2
	Integer	DeviceTLVersionSubMinor	Device TL Version Sub Minor	Beginner	RO	0	0
	Enumeration	DeviceRegistersEndianness	Device Registers Endianness	Guru	RO	0	Big (1)
	Enumeration	DeviceCharacterSet	Device Character Set	Guru	RO	0	UTF8 (1)
	Integer	DeviceLinkSelector	Device Link Selector	Beginner	RW	0	0
	Integer	DeviceLinkSpeed	Device Link Speed	Expert	RO	0	1000000000
	Integer	DeviceEventChannelCount	Device Event Channel Count	Expert	RO	1	1
	Integer	DeviceStreamChannelCount	Device Stream Channel Count	Expert	RO	1	1
	Float	DeviceLinkHeartbeatTimeout	Device Link Heartbeat Timeout	Guru	RW	0	3000000
	Command	TimestampReset	Timestamp Reset	Expert	WO	-	-
	Command	TimestampLatch	Timestamp Latch	Expert	WO	-	-
	Integer	TimestampLatchValue	Timestamp Latch Value	Expert	RO	0	0
	Integer	DeviceStreamChannelSelector	Device Stream Channel Selector	Expert	RW	0	0
	Enumeration	DeviceStreamChannelEndianness	Device Stream Channel Endianness	Guru	RO	0	Little (0)
	Integer	DeviceStreamChannelPacketSize	Device Stream Channel Packet Size	Expert	RW	0	576
	ImageFormatControl	Enumeration	SensorShutterMode	Sensor Shutter Mode	Guru	RW	0
Integer		WidthMax	Width Max	Expert	RO	0	752
Integer		HeightMax	Height Max	Expert	RO	0	480
Integer		Width	Width	Beginner	RW	0	752
Integer		Height	Height	Beginner	RW	0	480
Integer		OffsetX	Offset X	Beginner	RW	0	0
Integer		OffsetY	Offset Y	Beginner	RW	0	0
Integer		LinePitch	Line Pitch	Expert	RO	0	752
Enumeration		PixelFormat	Pixel Format	Beginner	RW	0	Mono8 (0x01080001)
Enumeration		TestPattern	Test Pattern	Beginner	RW	0	Off (0)
AcquisitionControl	Enumeration	AcquisitionMode	Acquisition Mode	Beginner	RW	0	Continuous (1)
	Command	AcquisitionStart	Acquisition Start	Beginner	RW	-	-
	Command	AcquisitionStop	Acquisition Stop	Beginner	RW	-	-
	Float	AcquisitionFrameRate	Acquisition Frame Rate	Beginner	RW	0	30
	Enumeration	TriggerSelector	Trigger Selector	Beginner	RW	0	FrameStart (0)
	Enumeration	TriggerMode	Trigger Mode	Beginner	RW	0	Off (0)
	Command	TriggerSoftware	Trigger Software	Beginner	WO	-	-
	Enumeration	TriggerSource	Trigger Source	Beginner	RO	0	Software (0)
	Enumeration	ExposureMode	Exposure Mode	Beginner	RO	0	Timed (0)
	Enumeration	ExposureTime	Exposure Time	Beginner	RW	0	33332.8 (ExposureAuto=Off)
AnalogControl	Enumeration	ExposureAuto	Exposure Auto	Beginner	RW	0	Continuous (1)
	Enumeration	GainSelector	Gain Selector	Beginner	RW	0	All (0)
	Float	Gain	Gain	Beginner	RW	0	1 (GainAuto=Off)
	Enumeration	GainAuto	Gain Auto	Beginner	RW	0	Continuous (1)
UserSetControl	Enumeration	GammaMode	Gamma Mode	Beginner	RW	0	0
	Enumeration	UserSetSelector	User Set Selector	Beginner	RW	0	UserSet1 (1)
	Command	UserSetLoad	User Set Load	Beginner	WO	-	-
TransportLayerControl	Command	UserSetSave	User Set Save	Beginner	WO	-	-
	Integer	PayloadSize	Payload Size	Expert	RO	0	360960
	Integer	GeVInterfaceSelector	GeV Interface Selector	Beginner	RW	0	0
	Integer	GeVMACAddress	GeV MAC Address	Beginner	RO	0	MAC Address
	Enumeration	GeVSupportedOptionSelector	GeV Supported Option Selector	Expert	RW	0	UserDefinedName (0)
	Boolean	GeVSupportedOption	GeV Supported Option	Expert	RO	0	UserDefinedName: True SerialNumber: True HeartbeatDisable: True LinkSpeed: True CCPApplicationSocket: False ManifestTable: False TestData: True DiscoveryAckDelay: False DiscoveryAckDelayWritable: False ExtendedStatusCodes: False PrimaryApplicationSwitchover: False Action: True PendingAck: False EventData: True Event: True PacketResend: True WriteMem: True CommandsConcatenation: True IPConfigurationLLA: True IPConfigurationDHCP: True IPConfigurationPersistentIP: True StreamChannelSourceSocket: False MessageChannelSourceSocket: False StreamChannelSourceSocket: False StreamChannelIPReassembly: False StreamChannelUnconditionalStreaming: False StreamChannelExtendedChunkData: False
	Boolean	GeVCurrentIPConfigurationLLA	GeV Current IP Configuration LLA	Beginner	RW	0	True
	Boolean	GeVCurrentIPConfigurationDHCP	GeV Current IP Configuration DHCP	Beginner	RW	0	True
	Boolean	GeVCurrentIPConfigurationPersistentIP	GeV Current IP Configuration Persistent IP	Beginner	RW	0	False
	Integer	GeVCurrentIPAddress	GeV Current IP Address	Beginner	RO	0	(It depends on network setting.)
	Integer	GeVCurrentSubnetMask	GeV Current Subnet Mask	Beginner	RO	0	(It depends on network setting.)
	Integer	GeVCurrentDefaultGateway	GeV Current Default Gateway	Beginner	RO	0	(It depends on network setting.)
	StringReq	GeVFirstURL	GeV First URL	Guru	RO	512	"Local:vcp1gem.xml;FE630000;Size"
	StringReq	GeVSecondURL	GeV Second URL	Guru	RO	512	"File:vcp1gem.xml"
	Integer	GeVPersistentIPAddress	GeV Persistent IP Address	Beginner	RW	0	169.254.100.100
	Integer	GeVPersistentSubnetMask	GeV Persistent Subnet Mask	Beginner	RW	0	255.255.0.0
	Integer	GeVPersistentDefaultGateway	GeV Persistent Default Gateway	Beginner	RW	0	169.254.100.1
	Enumeration	GeVCCP	GeV CCP	Guru	RW	0	OpenAccess (0)
	Integer	GeVMCPHostPort	GeV MCP Host Port	Guru	RW	0	0
	Integer	GeVMCDA	GeV MCDA	Guru	RW	0	0
Integer	GeVMCTT	GeV MCTT	Guru	RW	0	0	
Integer	GeVMCRC	GeV MCRC	Guru	RW	0	0	
Integer	GeVMCSP	GeV MCSP	Guru	RO	0	0x0007	
Integer	GeVStreamChannelSelector	GeV Stream Channel Selector	Expert	RW	0	0	
Integer	GeVSCPInterfaceIndex	GeV SCP Interface Index	Guru	RW	0	0	
Integer	GeVSCPHostPort	GeV SCP Host Port	Guru	RW	0	0	
Boolean	GeVSCPSFireTestPacket	GeV SCPS Fire Test Packet	Guru	RW	0	False	
Boolean	GeVSCPSDoNotFragment	GeV SCPS Do Not Fragment	Guru	RW	0	True	
Integer	GeVSCPSPacketSize	GeV SCPS Packet Size	Expert	RW	0	576	
Integer	GeVSCPD	GeV SCPD	Expert	RW	0	0	
Integer	GeVSCDA	GeV SCDA	Guru	RW	0	0	