

CIS

3G-SDI × 4ch

4K UHD TV CMOS

AF ZOOM Color Camera Module

DCC-4KZM

Product Specification

& Operational Manual

CIS Corporation

Table of Contents

1.	Handling Precautions.....	1
1.1.	Camera Handling Precautions.....	1
1.2.	Restrictions on Applications.....	1
1.3.	Disclaimers (Exception Clause).....	1
2.	Product Outline.....	2
2.1.	Features.....	2
2.2.	Accessories.....	2
3.	Specifications.....	3
3.1.	General Specifications.....	3
3.2.	External Connectors.....	5
3.2.1	Control Connector 1.....	5
3.2.2	Control Connector 2.....	6
3.2.3	Control Connector 3.....	6
3.2.4	Video Output Connector.....	6
3.2.5	mini USB Connector.....	7
4.	Camera Functions.....	8
4.1.	GenLock.....	8
4.2.	LTC (Longitudinal Time Code).....	8
4.3.	Defective Pixel Correction.....	9
4.3.1	Defective Pixel Data Type.....	9
4.3.2	Details on Defective Pixel Data.....	9
4.3.3	Notes for Defective Pixel Correction.....	10
5.	Serial Communication.....	11
5.1.	Serial Communication Settings.....	11
5.1.1	Changing Speed of Serial Communication.....	12
5.2.	Command List.....	13
5.3.	Quick Reference Table for Gain Settings.....	25
5.4.	Quick Reference Table for Shutter Settings.....	26
5.5.	Quick Reference Table for Iris Settings.....	27
5.6.	Quick Reference Table for Focal Length Settings.....	28
6.	Dimensions.....	29
6.1.	Camera Dimensions.....	29
7.	Case for Indemnity (Limited Warranty).....	30
7.1.	Product Warranty.....	30
7.2.	CMOS Defective Pixels.....	30
8.	Product Support.....	30

1. Handling Precautions

1.1. Camera Handling Precautions

- Please make sure to take appropriate measures for heat dissipation. This camera module is not designed to operate without heat dissipation. Operation without heat dissipation may cause damages.
- Do not use or store camera module in dusty or humid places.
- Please make sure to use fully dust-proof chassis/casing to avoid dust reaching the surface of the image sensor. Assemble camera module to your products under clean environment such as clean room.
- Do not apply excessive force, vibration, or static electricity that could damage camera module. Please handle camera module with care.
- Do not shoot direct images that are extremely bright (e.g., strong light source, sun, etc.). When extremely strong light source is shot, smear or blooming may occur. Put the lens cap on when camera is not in use.
- When strong light irradiates the lens-barrel of camera module, a leak of light could reach the surface of the image sensor and its projection could have bad influence on the output images. Please make sure that the camera module is shielded and there is no leak of light irradiating.
- Follow the instructions in [Chapter 3.2., "External Connector"](#) for connecting camera module. Improper connection may cause damages not only to the camera module but also to the connected devices.
- Confirm mutual ground potential carefully before connecting camera module to monitors or computers. Any AC leak from the connected devices may cause damages or destroy the camera module.
- Do not apply excessive voltage. (Use only the specified voltage.) Unstable or improper power supply voltage may cause damages or malfunction of the camera module.
- Carefully refer to Section 6.1. Camera Dimensions and use appropriate screws to mount or fix the camera module into your products.

Our warranty does not apply to damages or defects caused by neglecting the instructions and precautions explained in this manual.

1.2. Restrictions on Applications

- The camera module must not be used for any nuclear equipment or aerospace equipment with which mechanical failure or malfunction could result in serious bodily injury or loss of human life.
- The camera module must not be used under conditions or environments other than those specified in this manual.

1.3. Disclaimers (Exception Clause)

CIS should not be liable for any damages or losses if;

- damages or losses are caused by earthquake, lightning strike, fire, flood, or other acts of God.
- damages or losses are caused by deliberate or accidental misuse by user, or failure to observe information and instructions explained in this manual.
- damages or losses are caused by repair or modification conducted by user or any unauthorized party.
- deterioration of image quality is caused by dust adhered to image sensor area after shipment.
- deterioration of image quality is caused by scratches on image sensor and optical parts damaged by user.

2. Product Outline

DCC-4KZM is a 4K UHD TV color camera module with x18 auto focus zoom lens. Using a 1/1.8" rolling shutter CMOS image sensor, the maximum frame rate achieves 60fps. 3G-SDI x 4 interface and features CIS proprietary ISP, "Clairvu™" image processing engine for superb imaging quality and high-speed processing. Complies with BT.2020 (Wide color gamut) and BT.2100 (Hybrid Log-Gamma). Suitable for broadcasting applications, VR/AR systems, medical imaging systems, and other life science systems.

2.1. Features

- Features CIS proprietary ISP, state-of-the-art "Clairvu™" for superb imaging quality.
- x18 auto focus zoom lens.
- Noise reduction function (2DNR and 3DNR)
- GenLock function (3-values analog signals or Black burst).
- Supports RS-232C control and RS-422 control.
- Dimensions: 65mm (H) × 66mm (W) × 98mm (D) without projection.

2.2. Accessories

Standard accessory

- Lens cap

Software

- ※ CIS control software is available for evaluation purpose only.

CIS should be held harmless for any damage arising from the use of this control software.

The purpose of this control software is restricted to evaluation and testing of this product only, and is not intended for commercial use by customer.

CIS will not customize the program nor provide the source code.

3. Specifications

3.1. General Specifications

Electrical Specifications		
Image sensor	Sensor type	1/1.8" rolling shutter type color CMOS sensor
	Unit cell Size	2.0μm(H) × 2.0μm(V)
Resolution	UHDTV (4ch output)	3840 (H) × 2160 (V)
	1080p (1ch output)	1920 (H) × 1080 (V)
Aspect ratio	16 : 9	
Video output format	3840 x2160p YUV422 @60, 59.94, 50 fps (Level A)	3G-SDI ×4 - 2SI / Square Division
	3840 x2160p YUV422 @60, 59.94, 50 fps (Level B)	3G-SDI ×4 - Square Division
	3840 x2160p YUV444 @30, 29.97, 25, 24, 23.98 fps (Level A)	3G-SDI ×4 - 2SI
	1920 x 1080p YUV422 @60, 59.94, 50 fps (Level A / B)	3G-SDI ×1
	1920 x 1080 i YUV422 @60, 59.94, 50 fps	HD-SDI ×1
Sync system	Internal sync. / External sync.	
Video output standard	HD-SDI and 3G-SDI : Y/Pb/Pr(10bit) HIROSE H.FL75 connector Characteristic impedance 75Ω	
Sensitivity	F4.0 (2000 lx)	
Minimum illumination	0.7 lx (Conditions: AGC+48dB, iris fully open, electric shutter OFF)	
Gain variable range	AGC : 0dB ~ +48 dB ※Noises may become noticeable with high gain setting.	
	MANUAL : 0dB ~ + 48 dB	
Shutter speed variable range	AUTO : 1/13600s ~ 1/23.98s (Upper and lower limits can be set. Minimum shutter speed is limited by frame rate.)	
	MANUAL : 1/13600s ~ 1/23.98s (Minimum shutter speed is limited by frame rate.)	
White balance adjustment	AUTO: Standard, Outdoor, Fluorescent	
	MANUAL: Red Gain, Blue Gain, One Push	
	PRESET: Custom (Color temperature settings), Tungsten(3200K), Daylight(5500K), Cloudy(6500K), Shade(8000K)	
Auto exposure detection	Average, Center-Weighted, Spot(1/256), Backlight Compensation	
Flicker cancellation	ON, OFF	
Edge enhancement	OFF, 1~7	
Color correction	Auto, Standard, Fluorescent Light, Tungsten Lamp	
Saturation adjustment	0% (B/W) ~ 100%(typ.) ~ 200%	
Cyan suppression adjustment	0 ~ 15	
Color saturation suppression	OFF, 1~7	
Noise reduction	OFF, 1~6	
Gamma	Complies with BT.709 curve: Contrast -2, -1, 0, +1, +2 Complies with BT.2100 (HLG)	
Dynamic range	Low (for better SNR), Normal, High	
Knee point	OFF, 100%, 95%, 90%, 85%, 80%, 75%	
Color gamut	Complies with BT.709 and BT.2020	

Electrical Specifications (continued)	
Master pedestal	-100 ~ 0 ~ +100
Pedestal (R,G,B)	RGB independent: -100 ~ 0 ~ +100
Color balance	RGB independent: 0 ~ 100 ~ 200
Built-in lens	x18 Auto focus zoom lens f=6.8~120mm / maximum aperture F value 1.61 (wide) ~ 4.13 (tele)
Pixel defect correction (white spot)	Corrected upon shipment.
LTC	OFF, ON Accepts external SMPTE Time code in the LTC IN terminal. (Supports resetting internal time code.)
Camera preset settings	1, 2, 3, and 4 (Four kinds of preset to store.)
Remote control communications	Supports RS-232 signals and RS-422 signals to control camera settings. Refer to Section 5. Serial Communication for details.
Power requirements	DC +9~+15V
Power consumption	Typ: 13W / max 16W

Mechanical Specifications	
Dimensions	H: 65mm W: 66mm D: 98mm excluding projection. Refer to Section 6. Dimensions for details.
Weight	316g

Environmental Specifications			
Safety/Quality standards			
UL: Conform to UL Standard including materials.			
RoHS: 2011/65/EU EN50581 (RoHS2)			
Durability ※1	Vibration	Acceleration	: 3G
		Frequency	: 10~150 Hz
		Direction	: X, Y, and Z 3 directions
		Testing time	: 30 minutes each
	Shock	No malfunction after 10 times drop from 60 cm height on 6 surfaces, 3 edges, and 1 corner.	
Operational Temperature		Lowest temperature: -5 °C Highest temperature: Ambient temperature must be under 45°C and FPGA temperature should not exceed 80 °C. (Check with temperature measurement function.) Please refer to Section 6. Dimensions for the position of FPGA and heat dissipation point.	
Storage Temperature		-30 ~ +60°C Humidity: 20 ~ 80%RH with no condensation.	

※ This model is a sub-assembly model for manufacturers for further fabrication and incorporation into a final product. The equipment manufacturer who buys this model is responsible for obtaining the necessary Safety standards authorization such as CE and FCC prior to further marketing.

3.2. External Connectors

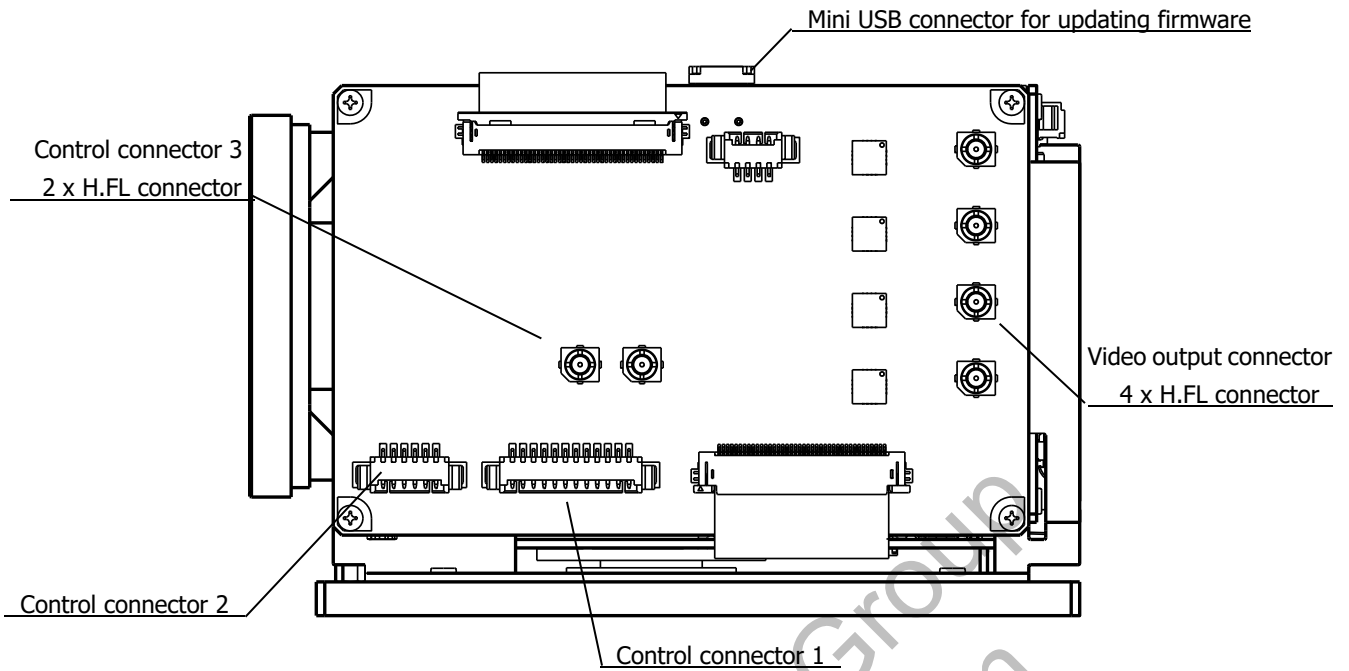

3.2.1 Control Connector 1

Model name: 53261-1271 (MOLEX)



Pin No.	Signals
1	GND
2	Power IN (DC+12V)
3	Reserved terminal (Do not connect)
4	RS-232C RXD In
5	Reserved terminal (Do not connect)
6	RS-232C TXD Out
7	Reserved terminal (Do not connect)
8	GND
9	Reserved terminal (Do not connect)
10	GND
11	Power IN (DC+12V)
12	Power OUT +5V (Option)

3.2.2 Control Connector 2

Model name: 53261-0671 (MOLEX)

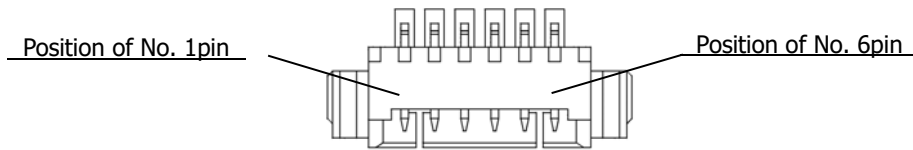

Pin No.	Signals
1	GND
2	RS-422 TXn OUT
3	RS-422 TXp OUT
4	RS-422 RXn IN
5	RS-422 RXp IN
6	GND

3.2.3 Control Connector 3

Model name: H.FL-R-SMT (HIROSE)

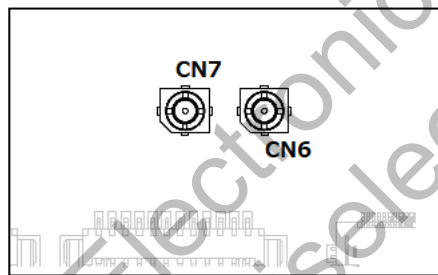

Reference No.	Signals
CN6	EXT SYNC IN (75ohm terminal)
CN7	LTC IN

3.2.4 Video Output Connector

Model name: H.FL-R-SMT (HIROSE)

	Pin No.	Signals
	A	3G-SDI output CH0 (Upper left with SQD) HD-SDI output
	B	3G-SDI output CH1 (Upper right with SQD)
	C	3G-SDI output CH2 (Lower left with SQD)
	D	3G-SDI output CH3 (Lower right with SQD)

3.2.5 mini USB Connector

Model name: UX60R-MB-5ST (HIROSE)

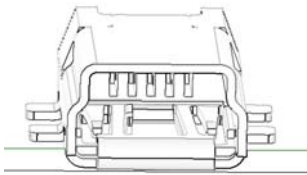
	Pin No.	Signals
	1	USB VBUS
	2	USB D-
	3	USB D+
	4	N.C
5	GND	

Aegis Electronic Group
www.aegiselect.com

4. Camera Functions

4.1. GenLock

Gen Lock function is available by inputting analog external sync signals (black burst or 3-values SYNC) into the EXT SYNC IN terminal of the control connector. Corresponding external sync signals vary depending on camera output format. Please refer to the chart below for details.

CAMERA FORMAT	EXT SYNC IN				
UHD/HD 60p/60i			1080i60	720p60	1080p30
UHD/HD 59.9p/59.9i	NTSC		1080i59.9	720p59.9	1080p29.9
UHD/HD 50p/50i		PAL	1080i50	720p50	1080p25
UHD 30p			1080i60	720p60	1080p30
UHD 29.9p	NTSC		1080i59.9	720p59.9	1080p29.9
UHD 25p		PAL	1080i50	720p50	1080p25
UHD 24p					1080p24
UHD 23.9p					1080p23.9

- Input Black Burst signals for NTSC/PAL signals.
- Input 3-values SYNC signals for non-NTSC/PAL signals.
- EXT SYNC IN terminal is 75Ω terminated.
- When an external signal in the above list is input, the camera automatically enters the external sync mode.
- When no external sync signal is input, the camera operates in internal sync mode.
- Immediately after an external sync signal is input, the image will be distorted, but this is not a malfunction.
- If a signal is input to the EXT SYNC IN terminal in a combination other than the above, the image may be distorted or may not be output.
- After camera startup and output format switching, the video signal will have an error of up to ±10 pixels relative to the external sync signal. If this error is unacceptable, please fine-tune the external sync lock automatically and then use the user adjustment commands.

4.2. LTC (Longitudinal Time Code)

Supports Time Code insertion to 3G-SDI signals.

By inputting an LTC (time code) signal to the LTC IN terminal of the control connector, user can insert an external time code. If there is no input to the LTC IN terminal, user can insert internal time code.

The internal time code starts at 00:00:00:00 upon power-on but is set to the external time code when a signal is input to the LTC IN terminal. If there is no more signal at the LTC IN terminal in that state, it runs itself from the set time code.

Signal format: SMPTE Time code
Signal level: 0.5~2[Vp-p]

4.3. Defective Pixel Correction

In addition to the correction of defective pixel data registered upon shipment, we provide a method to update the defective pixel data. Please refer to [Section 5.2, Command List](#) for details.

4.3.1 Defective Pixel Data Type

There are two types of defective pixel data.

- Defective data registered at factory
Data registered upon shipment from our factory. These data cannot be over-written.
- Defective data registered by user
Data registered by user. These data can be over-written freely.

In H Flip and V Flip modes, command automatically converts coordinates of defective pixels with a shift of one pixel. This is due to the image sensor specifications.

4.3.2 Details on Defective Pixel Data

Defective pixel data are stored and controlled per four vertically divided regions. User can register up to 64 points per region, which makes it a total of 256 points as user register data. There are overlaps of 32 pixels (width) between the regions. The command registers the defective pixel coordinates in the overlapping area to both regions. Please refer to the below for the definition of regions.

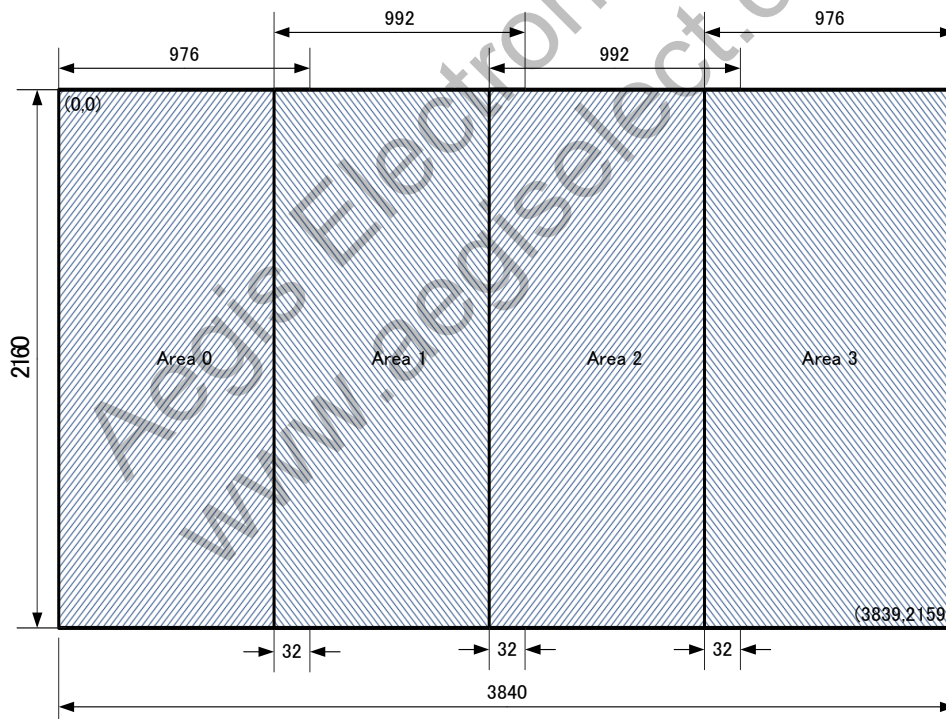

The upper left is the origin of coordinate system. Definition of each region is

- Reed Area 0: (0,0) – (975,2159)
- Reed Area 1: (944,0) – (1935,2159)
- Reed Area 2: (1904,0) – (2895,2159)
- Reed Area 3: (2864,0) – (3839,2159)

For example, if the defective pixel is at (943, 0), the data is registered only to region 0.

However, if the defective pixel is at (944, 0), the data is registered to both region 0 and 1.

4.3.3 Notes for Defective Pixel Correction

- To save the data registered or deleted with defective pixel correction command (SU 200~203), execute SAVE command (SU705).
- Init command (SU 700) does not restore defective pixel correction data. Use SU 203 to delete all data.
- Defective pixel correction data is not subject to Camera Setting Store/Load command (SU 100/101).
- Factory data and user register data cannot be the same. Therefore, if user detects the same defective points, this function ignores those points.
- If user specifies the same coordinates as factory setting data, error will occur.
- Please note that the detected results may not always be the same due to temperature, noise, and other conditions.

Neglecting these instructions may cause not only incorrect pixel defect correction, but also failure of acquiring proper images.

Aegis Electronic Group
www.aegiselect.com

5. Serial Communication

5.1. Serial Communication Settings

(1) Please refer to the chart below for serial communication settings.

Baud rate	9,600bps (factory setting), 38400bps, 115200bps
Data	8bit
Stop bit	1bit
Parity	None
XON/XOFF	No Control

(2) Control code

- Text-based communication executes camera control. Only ASCII 0x20~0x7E, 0x0A (LF=¥n), and 0x0D (CR=¥r) must be used. Please do not use other than these codes.
- By sending command, Parameter, and linefeed code from host to camera, user can change camera settings and acquire camera-setting Parameters. Either CR or LF can be a linefeed code.
- There are two types of commands. One is SU command to send settings and instructions to the camera ("S" for "Set"), and the other is GU command ("G" for "Get") to obtain information from the camera.

Command	Parameter 1	Parameter 2	Function
GU	Address	None (with some exceptions)	To obtain camera setting information.
SU	Address	Data (There may be more than one)	To change camera settings.

(3) How to set a command

- ">" must be output from the camera as a prompt.
- Commands are not case-sensitive.
- Separate between a command and a Parameter by single space (0x20).
- From the head of the input character to the linefeed code (CR) is defined as a single serial command.
- Parameters start with 0x are regarded as hexadecimal, Parameters start with 0b are regarded as binary, and others are regarded as decimal.
- Commands analyze Parameters from the head to identifiable letters.
- Please refer to "[Section 5.2. Command List](#)" for details on address and data.
- Do not input values and letters other than those explained in the above and those mentioned in "[Section 5.2. Command List](#)."
- Camera receives the returned command from Host and echo the command back. At this time, camera converts the linefeed code (CR) to CR LF and echo the code back.

(4) Other notes

- Commands specified per pixel (AF frame, cross line position, and defective pixels related commands) are always specified by 3840 x 2160 coordinates regardless of video format settings.

(5) Setting examples

【Example of GU command】

To get information of address 10

[Send] GU [sp] 10[¥r]

[Returned value] GU [sp] 10[¥r] [¥n]

[Returned value] 50[¥r] [¥n]

[Returned value] [¥r] [¥n]

[Returned value] > [sp]

[Echo back]

[Acquired data + Linefeed]

[Linefeed]

[Prompt (> and space)]

[¥r]=CR (0x0D)

[¥n]=LF (0x0A)

[sp]=Space (0x20)

【Example of SU command】

To set 30 to address 10

[Send]	SU [sp] 10[sp] 30[¥r]	
[Returned value]	SU [sp] 10[sp] 30[¥r] [¥n]	[Echo back]
[Returned value]	[¥r] [¥n]	[Linefeed]
[Returned value]	> [sp]	[Prompt (> and space)]

5.1.1 Changing Speed of Serial Communication

Baud rate command (SU 725) changes transfer rate of serial communication out of 9600bps, 38400bps, and 115200bps.

- The changes made are reflected after re-booting camera, not immediately after executing the command.
- Execute SAVE command (SU 705) to save the setting values.
- Baud rate command is not subject to Init command (SU 700) so that executing Init command does not restore settings.
- Baud rate command is not subject to Camera Setting Store/Load command (SU 100/101).
- Only when baud rate setting is 9600bps, user can use the optional remote controller RU-100.

5.2. Command List

Video Format

Function	Address	Setting Value	Initial Value	Description
Video Format	1	0: UHDTV 2-Sample Interleave 60p (Level A) 1: UHDTV 2-Sample Interleave 59.94p (Level A) 2: UHDTV 2-Sample Interleave 50p (Level A) 3: UHDTV Square Division 60p (Level A) 4: UHDTV Square Division 59.94p (Level A) 5: UHDTV Square Division 50p (Level A) 6: Full-HD 60p (Level A) 7: Full-HD 59.94p (Level A) 8: Full-HD 50p (Level A) 9: Full-HD 60p (Level B) 10: Full-HD 59.94p (Level B) 11: Full-HD 50p (Level B) 12: UHDTV Square Division 60p (Level B) 13: UHDTV Square Division 59.94p (Level B) 14: UHDTV Square Division 50p (Level B) 15: Full-HD 60i 16: Full-HD 59.94i 17: Full-HD 50i 18: UHDTV 2-Sample Interleave 30p 444 (Level A) 19: UHDTV 2-Sample Interleave 29.97p 444 (Level A) 20: UHDTV 2-Sample Interleave 25p 444 (Level A) 21: UHDTV 2-Sample Interleave 24p 444 (Level A) 22: UHDTV 2-Sample Interleave 23.98p 444 (Level A)	0	This is to set video output format.

AE related

Function	Address	Setting Value	Initial Value	Description
Gain Mode	2	0: Manual 1: Auto	1	This is to set gain control mode.
Gain Value	3	Magnification×0×10000 Setting range: 1~approx.251 (0x10000~0xFB304B)	0x10000 (65536)	This is to set gain value when gain mode is Manual. (*1) e.g.) To set x2 (approx. 6dB): SU 3 0x00020000 ※ Please Refer to Section 5.3. Quick Reference Table for Gain Settings.
Gain Max Value	4	Magnification×0×10000 Setting range: 1~approx.251 (0x10000~0xFB304B)	0x200000 (2097152)	This is to set the maximum gain value when gain mode is Auto. (*1) ※ Please refer to Section 5.3. Quick Reference Table for Gain Settings.
Shutter Mode	5	0: Manual 1: Auto	1	This is to set shutter control mode.
Shutter Value	6	Exposure [s]×0×100000 Setting range: 1/13600~1/23.98s (0x4D~0xAAD6)	0x4444 (17476) 1/60s	This is to set shutter value (exposure time) when shutter mode is Manual. (*1) Set a shorter value than 1 frame length. For example, when video format is 60fps, the maximum shutter value will be 0x4444 (1/60s). ※ Please refer to Section 5.4 Quick Reference Table for Shutter Settings.
Shutter Limit	7	The 1 st Parameter: Max value Exposure [s]×0×100000 Setting range: 1/13600~1/23.98s (0x4D~0xAAD6)	0x4444 (17476) 1/60s	This is to set shutter variable range when shutter mode is Auto. (*1) Set a shorter value than 1 frame length. Max<Min is invalid. e.g.) To set Max=1/60s, Min=1/8000s: SU 7 0x4444 0x83 ※ Please refer to Section 5.4 Quick Reference Table for Shutter Settings.
		The 2 nd Parameter: Min value Exposure [s]×0×100000 Setting range: Same as Max value.	0x4D (77) 1/13600s	
Iris Mode	61	0: Manual 1: Auto	1	This is to set iris control mode.
Maximum Aperture	63	None	None	This is to acquire the current maximum aperture F value. (GU only). F value varies depending on zoom position.
Aperture Value	64	0: Close 0x800(F22.6)~ 0x62C30(F1.61)	0x62C30 (404528)	This is to set aperture value when Iris Mode is Manual (*1). Calculates aperture value with F value. Aperture Value = 0x100000 / (F value×F value) e.g.) To set F4.0: SU 64 0x10000 Please refer to Section 5.5 Quick Reference Table or Iris Settings.

AE related

Function	Address	Setting Value	Initial Value	Description
Aperture Limit	65	The 1 st Parameter: Max value 0x800~0x62C30	0x62C30 (404528)	This is to set variable range of aperture value when Iris Mode is Auto. (*1) Max < Min is invalid. e.g.) To set Max=F2.0, Min=F8.0; SU 65 0x40000 0x4000
		The 2 nd Parameter: Min value 0x800~0x62C30	0x800 (2048)	
Metering Mode	8	0: Average 1: Center-Weighted 2: Spot 3: Backlight Compensation	1	This is to set metering mode.
Spot Block	9	The 1 st Parameter: X value: 0~15	7	This is to set X, Y, W, and H values for Spot metering. X: Far left of metering field Block, X coordinate Y: Top of metering field Block, Y coordinate W: Width of metering field (number of block) H: Height of metering field (number of block) e.g.) Execute SU 9 6 7 4 2 to set 4x2 block from the coordinate (6, 7).
		The 2 nd Parameter: Y value: 0~15	7	
		The 3 rd Parameter: W value: 1~16	2	
		The 4 th Parameter: H value: 1~16	2	
AE Speed	10	0~15	10	This is to set AE convergence speed.
Exposure Compensation Value	11	0(-12dB)~12(0dB)~24(+12dB)/per 1dB	12	This is to set exposure compensation value.
Flicker Cancel	12	0: Off 1: On	0	This is to set ON/OFF flicker cancel. Enabled only when video format is 60fps, 59.94fps, 30fps, and 29.97fps.
Gain Value, Plus Minus	13	-1: decrease 1dB 1 : increase 1dB	None	This is to change gain value by ± 1 dB from the current setting. (*1) Enabled when gain mode is Manual. (Dedicated to SU)
Shutter Speed, Plus Minus	14	-1: decrease 1step (1/4EV) 1 : increase 1step (1/4EV)	None	This is to change shutter speed by ± 1 step (1/4EV) from the current value. Decreasing shutter speed by 1step makes shutter value becomes bigger. (*1) Enabled when shutter mode is Manual. (Dedicated to SU)
Iris(F-number), Plus Minus	15	-1: decrease 1step (1/4EV) 1 : increase 1step (1/4EV)	None	This is to change F value of iris by ± 1 step (1/4EV) from the current setting. Decreasing F value by 1step makes aperture value becomes bigger. (*1) Enabled when iris mode is Manual. (Dedicated to SU)

AE related

Function	Address	Setting Value	Initial Value	Description
Current Gain	55	None	None	This is to acquire the current gain. (Dedicated to GU) (*1)
Current Shutter	56	None	None	This is to acquire the current shutter value. (Dedicated to GU) (*1)
Current Aperture	57	None	None	This is to acquire the current aperture value. (Dedicated to GU) (*1)

(*1) Note that in some cases, the specified values may not be reflected due to the physical limitation of the lens. One such instance is with the iris control, whereby the zoom position of the lens determines the maximum F value, and thus, depending on the zoom position of the lens, the actual F value can vary from the theoretical F value specified by the iris setting parameter. You can confirm the actual values with Current Gain, Current Shutter, and Current Aperture commands.

WB related

Function	Address	Setting Value	Initial Value	Description
WB Mode	20	0: Manual 1: Auto 2: Preset	1	This is to set White Balance (WB) mode.
WB Manual Memory	21	0~4	0	This is to choose the memory to store setting values when WB Mode is Manual. Memory stores up to 5 types of settings (0~4).
Manual Red Gain	22	100~1600 (%)	191	This is to set Red Gain when WB Mode is Manual.
Manual Blue Gain	23	100~1600 (%)	179	This is to set Blue Gain when WB Mode is Manual.
One Push Trigger	24	1: W×H 2: W/2×H/2 3: W/4×H/4	None	This is to execute One Push WB when WB mode is Manual. Choose a detection range with setting values. If execution of One Push WB is not properly processed, camera will return Run Time Error. (Do not shield light to execute this command). (Dedicated to SU)
WB Auto Func	25	0: Standard 1: Outdoor 2: Fluorescent	0	This is to choose the condition when WB Mode is Auto.
WB Preset Func	26	0: Custom 1: Tungsten (3200K) 2: Daylight (5500K) 3: Cloudy (6500K) 4: Shade (8000K)	2	This is to choose the environmental lighting condition when WB Mode is Preset.
WB Preset Temp	27	2500~15000(K)	5500	This is to set color temperature when WB Preset Func is Custom.
WB LB Shift	28	-10~10	0	This is to set shift amount of WB gain toward black.
WB CC Shift	29	-10~10	0	This is to set the shift amount of WB gain toward green magenta.
Current Red Gain	58	None	None	This is to acquire the current Red Gain. (Dedicated to GU)
Current Blue Gain	59	None	None	This is to acquire the current Blue Gain. (Dedicated to GU)

Image Quality related

Function	Address	Setting Value	Initial Value	Description
Detail (Edge Enhancement)	30	0: Off 1: (Low)~7(High)	3	This is to set the strength of edge enhancement.
Gamma	35	0: BT.709 -2 1: BT.709 -1 2: BT.709 3: BT.709 +1 4: BT.709 +2 5: HLG75	2	This is to set gamma type and contrast. 0~4 are the curves comply with BT.709. Contrast changes in the range of -2 ~ +2. 5 is for HLG75 that means 75% output level is regarded as 100% input level.
Knee	36	0: Off 1: 100% 2: 95% 3: 90% 4: 85% 5: 80% 6: 75%	4	This is to set knee point. Enabled except when Gamma is BT.709 and D-range is Low. Knee slope varies according to the selected maximum D-Range.
Master Pedestal	37	-100~+100	0	This is to set Master pedestal.
Red Pedestal	38	-100~+100	0	This is to set Red pedestal.
Green Pedestal	39	-100~+100	0	This is to set Green pedestal.
Blue Pedestal	40	-100~+100	0	This is to set Blue pedestal.
Red Balance	41	0~200	100	This is to set Red balance.
Green Balance	42	0~200	100	This is to set Green balance.
Blue Balance	43	0~200	100	This is to set Blue balance.
D-Range	44	0: Low Equivalent to 120% for BT.709 Disabled with HLG (Handled as Normal) 1: Normal Equivalent to 200% for BT.709 Equivalent to 600% for HLG 2: High 400% for BT.709 Equivalent to 1200% for HLG	1	This is to set Dynamic range. With Low, both D range and sensitivity decrease, but noise level becomes the lowest. With High, the minimum gain value will be limited to 0x20000. (Even if a lower value is set, gain value becomes 0x20000.) ※ The definition of D-range for BT.709 and HLG are different, ref. below. [BT.709] 100% output level (without Knee) is regarded as 100% input level. [HLG] 50% output level is regarded as 100% input level.

Image Quality related

Function	Address	Setting Value	Initial Value	Description
Color Saturation	45	0~200	100	This is to set color saturation.
Cyan Suppression	46	0~15	15	This is to set suppression for Cyan saturation.
Color Adjustment	47	The 1 st Parameter: Selection of color 0: Magenta 1: Red 2: Yellow 3: Green 4: Cyan 5: Blue	All 0	This is to set color adjustment values. There are three kinds of adjustment items for each 6 colors, which makes it a total of 18 parameters for color adjustment. e.g.) To set -3 to Cyan Hue SU 47 4 0 -3
		The 2 nd Parameter: Selection of item to adjust 0: Hue 1: Saturation 2: Depth		To execute GU, please specify the 1 st parameter and the 2 nd parameter as well.
		The 3 rd Parameter: Adjustment value -20~20		e.g.) To acquire adjustment value of Cyan Hue GU 47 4 0
Noise Reduction	50	0: Off 1 (Low)~6 (High)	3	This is to set the level of noise reduction. With level 1, only 2DNR is enabled. With level 2 and over, both 2DNR and 3DNR are enabled. When output video format is 2-sample interleave or Full HD, you can choose a level out of 0~6. When output format is Square division, 3DNR is disabled and noise reduction level is limited to 1. (*2)
Color Correction	52	0: Auto 1: Standard 2: Fluorescent Light 3: Tungsten Lamp	0	This is to set color correction.
Color Suppression	53	0: Off 1 (Low)~7(High)	0	This is to set color suppression.
Color Space	54	0: BT.709 1: BT.2020	0	This is to set color gamut.

(*2): When intensity increase, residual images may become evident.

Lens Control related

Function	Address	Setting Value	Initial Value	Description
Zoom Drive	66	The 1 st Parameter: Move mode 0: To specify absolute zoom position 1: To specify relative zoom position 2: To specify direction for zoom to move.	0	This is to move the zoom lens. There are three kinds of way to specify. Select with move mode. When move mode is 0 and 1, lens moves to the specified position and stops. When move mode is 2, lens starts moving according to the setting of -1 or 1 and stops with 0. (It also stops when lens reaches the wide edge or the tele edge). This command is non-blocking so that it returns prompt before completion of movement. (*3)
		The 2 nd Parameter: 【When move mode is 0】 0 (wide edge)~1024 (tele edge) 【When move mode is 1】 -1024 (wide)~1024 (tele) 【When move mode is 2】 -1: Move to wide direction 1: Move to tele direction 0: Stop	0	
		The 3 rd Parameter: Move speed 0~64	64	
Focus Drive	67	The 1 st Parameter: Move mode 0: To specify absolute focus position 1: To specify relative focus position 2: To specify direction for focus to move.	0	This is to move focus lens when focus mode is Manual. There are three kinds of way to specify. Select with move mode. When move mode is 0 and 1, lens moves to the specified position and stops. When move mode is 2, lens starts moving according to the setting of -1 or 1 and stops with 0. (It also stops when lens reaches the far edge or the near edge). This command is non-blocking so that it returns prompt before completion of movement. (*3)
		The 2 nd Parameter: 【When move mode is 0】 0 (far edge)~3584 (near edge) 【When move mode is 1】 -3584 (far)~3584 (near) 【When move mode is 2】 -1: Move to far direction 1: Move to near direction 0: Stop	0	
		The 3 rd Parameter: Move speed 0~64	64	
Focus Mode	68	0: Manual 1: Auto	1	This is to set focus control mode. (*4)
Focus One Push Trigger	69	1 (Fixed)	None	This is to execute One Push AF when focus mode is Manual. This command is non-blocking so that it returns prompt before completion of movement. With GU 69, user can acquire operating status of One Push AF. (0=stop, 1=in operation).

(*3): If user changes video format while the lens is moving (zooming), the lens stops movement.

(*4): In AF mode, AF may lose focus when abrupt zoom in/out is applied.

Lens Control related (cont.)

Function	Address	Setting Value	Initial Value	Description
Current zoom speed	71	None	None	This is to acquire the current zoom speed. (GU Only) (*5)
Current focus speed	72	None	None	This is to acquire the current focus speed. (GU Only) (*5)
AF Frame	73	The 1 st Parameter: X value 0~3360	480	This is to set AF detection area. X: X coordinate of the left edge of AF detection area Y: Y coordinate of the top of AF detection area W: Width of AF detection area H: Height of AF detection area When improper combination such as (X+W>3840 or Y+H>2160) are set, error will occur. e.g.) To set detection area 1029x1080 from the coordinates (960,540), SU 73 960 540 1920 1080
		The 2 nd Parameter: Y value 0~1890	270	
		The 3 rd Parameter: W value 480~3840	2880	
		The 4 th Parameter: H value 270~2160	1620	
Current ICF position	74	None	None	This is to acquire the current position of IR cut filter. (GU Only). Returns 0=Out or 1=In.
IR Cut Filter mode	75	0: IR cut filter Out 1: IR cut filter In 2: IR cut filter Auto	1	This is to set IR cut filter mode. Set OUT if you wish to remove the IR cut filter. The image automatically changes to monochrome. With Auto mode, control of IR cut filter Out/In automatically changes according to the gain value.
Auto ICF Threshold	76	The 1 st Parameter: Out Threshold 0x10000~0xFB304B	0x200000	This is to set the threshold when IR cut filter mode is Auto. Out Threshold: When IR cut filter mode is IN, it will become OUT if gain value exceeds this value. In Threshold: When IR cut filter mode is OUT, it will become IN if gain value becomes lower than this value. Out Threshold ≤ In Threshold is invalid.
		The 2 nd Parameter: In Threshold 0x10000~0xFB304B	0x10000	
Current Zoom Position	78	None	None	This is to acquire the current zoom position. (GU Only). (*6)
Current Focus Position	79	None	None	This is to acquire the current focus position. (GU Only). (*6)

(*5): If the Zoom Drive or Focus Drive is executed immediately after the move is instructed, it may return 0 before the move begins. If you wish to execute the Zoom Drive or Focus Drive to check the completion of movement, please leave at least one frame after the Zoom Drive or Focus Drive has been executed.

(*6): Since the zoom and focus positions are normalized values, they may not match the values set by Zoom Drive and Focus Drive. Also, the values may change depending on the position of the IR cut filter.

OSD related

Function	Address	Setting Value	Initial Value	Description
OSD Up button	90	0: 1 push 1: continuous push	None	Commands to operate OSD. Send commands every 60msec for continuous push. (SU Only)
OSD Down button	91	0: 1 push 1: continuous push	None	
OSD Right button	92	0: 1 push 1: continuous push	None	
OSD Left button	93	00: 1 push 1: continuous push	None	
OSD Center button	94	0: 1 push 1: continuous push	None	
Text Color	95	0: Black 1: Blue 2: Red 3: Magenta 4: Green 5: Cyan 6: Yellow 7: White	7	This is to set the text color of OSD menu.
Highlight Color	96	0: Black 1: Blue 2: Red 3: Magenta 4: Green 5: Cyan 6: Yellow 7: White	5	This is to set the selected letter's font color of OSD menu. If user specifies the same color as the text color, error will occur because the selected letters cannot be recognized.
OSD Off	99	1 (fixed)	None	This is to close OSD menu.

Others

Function	Address	Setting Value	Initial Value	Description
Camera Setting Store	100	0~3	0	User can store four kinds of camera settings. Execute SAVE (SU 705 1) to save the registered values into the nonvolatile memory. The registered data and address to store (the set value of this address) are not subject to Init command (SU 700 0).
Camera Setting Load	101	0~3		This is to read out and reflect the registered values set by Camera Setting Store to the camera. Selection of address to store and address to load are common so that this command keeps the last set values with Store or Load. (GU 100 and GU 101 always return the same value).

Others (Cont.)

Function	Address	Setting Value	Initial Value	Description
LTC Mode	103	0: Off 1: On	0	This is to set OFF/ON of LTC signals insertion.
LTC Reset	104	1: Reset	None	This is to reset the timer for internal self-run of LTC. (Dedicated to SU)
GenLock V Offset	106	-1024~1023	0	Adjustment of V phase when mode is external sync.
GenLock H Offset	107	-2048~2047	0	Adjustment of H phase when mode is external sync.
H Flip	110	0: Off 1: On	0	This is to set horizontal flip of the output image.
V Flip	111	0: Off 1: On	0	This is to set vertical flip of the output image.
Test Pattern	120	0: Off 1: Cross Line 2: Color Bar	0	This is to set test pattern indication. H Flip and V Flip setting does not affect the test pattern. (Test pattern does not flip).
Cross Line Position	121	The 1 st Parameter: X coordinate 0~3839	1920	This is to set the address of the crossing point when Cross Line is selected.
		The 2 nd Parameter: Y coordinate 0~2159	1080	
FPGA Temperature	180	None	None	This is to acquire FPGA temperature 【°C】(GU Only). Please take appropriate measures for heat dissipation. Value must not exceed 80.
Init	700	0 (fixed)	None	This is to restore camera settings to initial values. Camera store-data, address to store, defective pixel correction data, baud rate, and lens adjustment values are not subject to this command. (SU Only)
Save	705	1 (fixed)	None	This is to save camera settings. After storing the current camera settings by Store (Equivalent to SU100), this command saves the stored data, the address to store, defective pixel correction data, baud rate, and lens adjustment values. (SU Only) (*7)
Version Information	721	1: Microcomputer version 2: FPGA version	None	This is to acquire version information. (GU Only)
Baud Rate	725	9600, 38400, 115200 (bps)	9600	This is to set the speed of serial communication. Refer to Section 5.1.1. Changing Speed of Serial Communication for details.
SDI Compatibility Mode	750	0: Off 1: On	0	With factory setting (Off), if user selects HLG75 or BT.2020, changes made will be reflected to SDI Payload ID. With SDI compatibility mode ON however, changes made are not subject to reflect. Set this mode ON if you are using a receiving equipment, which outputs no image with HLG75 or BT.2020.

(*7) : As to Zoom Drive and Focus Drive, the current zoom position and focus position at execution of SAVE command will be saved instead of the set values. When loaded, the lens will return to the saved zoom and focus position.

Defective Pixel Correction

Function	Address	Setting Value	Description
Detection of defective pixel	200	The 1 st Parameter: Threshold level: 0 ~ 4095	This is to detect defective pixels (white defect) and register them as user register data. Defective pixels are output value, which exceeds the threshold level. Execute this command with light shielded and set appropriate gain and shutter values.
		The 2 nd Parameter: Registration mode 0: New registration 1: Additional registration	
Registration of defective pixel	201	The 1 st Parameter: X coordinate 0 ~ 3839	This is to register defective pixels as user register data by specifying their coordinates.
		The 2 nd Parameter: Y coordinate 0 ~ 2159	
Deletion of defective pixel	202	The 1 st Parameter: X coordinate: 0 ~ 3839	This is to delete defective pixels from user register data by specifying their coordinates. (Dedicated to SU)
		The 2 nd Parameter: Y coordinate 0 ~ 2159	
Deletion of defective pixel correction data	203	1: Entire deletion	This is to delete all user register Data. (Dedicated to SU)
Indication of defective pixel correction data	204	1: Indicate the coordinates and their attributes of all defective pixels. 2: Indicate the coordinates and their attributes of user register data. 3: Indicate the total number of all registered defective pixels per region. 4: Indicate the number of user register data per region.	This is to indicate information on the registered defective pixel correction data. (Dedicated to GU)

- When user specifies "new registration" with defective pixel detection command, the command deletes only user register data by defective pixel detection. The command does not delete data registered by defective pixel registration command.
- The command classifies the registered defective pixels into four types. Attribute [W] and [B] are for the data registered at factory, attribute [U] is the data registered by user with defective pixels detection command, and attribute [P] is the data registered by user with defective pixels registration command.
- [GU 200] command shows the number of pixels classified under [U] attribute, and [GU 201] command shows the number of pixels classified under [P] attribute.
- User can change only user register data and cannot remove the factory setting data.
- User cannot register the pixels already been registered as factory data.

Lens Adjustment

Function	Address	Setting Value	Initial Value	Description
Gain for fine tuning focus position	270	0 (x0) ~ 32 (x2)	16	This is to set gain for fine-tuning focus position. Effective as a gain against temperature offset Parameter. Specify values in the multiple of 16. (The initial value of 16 means x1). Usually, use with the initial value. This command is not subject to Camera Setting Store, Camera setting Load, and Init.
Offset for fine tuning focus position	271	-16 ~ 16	0	This is for defining offset value for fine-tuning the focus position. Effective as an offset against original zoom tracking curve. Usually, use with the initial value. This command is not subject to Camera Setting Store, Camera setting Load, and Init.

Aegis Electronic Group
www.aegiselect.com

5.3. Quick Reference Table for Gain Settings

	Magnification	dB	Gain Value (Mag.×0x10000)	
			DEC	HEX
0	1.000	0.000	65536	00010000
1	1.122	1.003	73561	00011F59
2	1.260	2.007	82570	0001428A
3	1.414	3.010	92681	00016A09
4	1.587	4.014	104031	0001965F
5	1.782	5.017	116771	0001C823
6	2.000	6.021	131072	00020000
7	2.245	7.024	147123	00023EB3
8	2.520	8.027	165140	00028514
9	2.828	9.031	185363	0002D413
10	3.175	10.034	208063	00032CBF
11	3.564	11.038	233543	00039047
12	4.000	12.041	262144	00040000
13	4.490	13.045	294246	00047D66
14	5.040	14.048	330280	00050A28
15	5.657	15.051	370727	0005A827
16	6.350	16.055	416127	0006597F
17	7.127	17.058	467087	0007208F
18	8.000	18.062	524288	00080000
19	8.980	19.065	588493	0008FACD
20	10.079	20.069	660561	000A1451
21	11.314	21.072	741455	000B504F
22	12.699	22.076	832255	000CB2FF
23	14.254	23.079	934175	000E411F
24	16.000	24.082	1048576	00100000
25	17.959	25.086	1176986	0011F59A
26	20.159	26.089	1321122	001428A2
27	22.627	27.093	1482910	0016A09E
28	25.398	28.096	1664510	001965FE
29	28.509	29.100	1868350	001C823E
30	32.000	30.103	2097152	00200000
31	35.919	31.106	2353974	0023EB36
32	40.317	32.110	2642246	00285146
33	45.255	33.113	2965821	002D413D
34	50.797	34.117	3329021	0032CBFD
35	57.018	35.120	3736700	0039047C
36	64.000	36.124	4194304	00400000
37	71.838	37.127	4707947	0047D66B
38	80.635	38.130	5284492	0050A28C
39	90.510	39.134	5931642	005A827A
40	101.594	40.137	6658043	006597FB
41	114.035	41.141	7473400	007208F8
42	128.000	42.144	8388608	00800000
43	143.675	43.148	9415894	008FACD6
44	161.270	44.151	10568984	00A14518
45	181.019	45.154	11863283	00B504F3
46	203.187	46.158	13316085	00CB2FF5
47	228.070	47.161	14946800	00E411F0
48	251.189	48.000	16461899	00FB304B

5.4. Quick Reference Table for Shutter Settings

Exposure time [s]	Shutter Value (Exposure time[s]×0x100000)	
	DEC	HEX
1/23.98	43734	0000AAD6
1/24	43691	0000AAAB
1/25	41943	0000A3D7
1/29.97	34987	000088AB
1/30	34953	00008889
1/50	20972	000051EC
1/59.94	17494	00004456
1/60	17476	00004444
1/90	11651	00002D83
1/100	10486	000028F6
1/125	8389	000020C5
1/180	5825	000016C1
1/250	4194	00001062
1/350	2996	00000BB4
1/500	2097	00000831
1/725	1446	000005A6
1/1000	1049	00000419
1/1500	699	000002BB
1/2000	524	0000020C
1/3000	350	0000015E
1/4000	262	00000106
1/6000	175	000000AF
1/8000	131	00000083
1/9600	109	0000006D
1/11200	94	0000005E
1/13600	77	0000004D

5.5. Quick Reference Table for Iris Settings

F Value	Aperture Value ((1/F2) × 0x100000)	
	DEC	HEX
22.6	2048	00000800
19.0	2896	00000B50
16.0	4096	00001000
13.5	5792	000016A0
11.3	8192	00002000
9.51	11585	00002D41
8.00	16384	00004000
6.73	23170	00005A82
5.66	32768	00008000
4.76	46340	0000B504
4.00	65536	00010000
3.36	92681	00016A09
2.83	131072	00020000
2.38	185363	0002D413
2.00	262144	00040000
1.68	370727	0005A827
1.61	404528	00062C30

5.6. Quick Reference Table for Focal Length Settings

Focal Length (Unit: mm)	Zoom Drive (Move mode0: Zoom absolute position)	
	DEC	HEX
6.83	0	0000
7.21	32	0020
7.63	64	0040
8.08	96	0060
8.56	128	0080
9.10	160	00A0
9.67	192	00C0
10.29	224	00E0
10.99	256	0100
11.73	288	0120
12.55	320	0140
13.48	352	0160
14.47	384	0180
15.56	416	01A0
16.81	448	01C0
18.16	480	01E0
19.66	512	0200
21.37	544	0220
23.24	576	0240
25.39	608	0260
27.74	640	0280
30.38	672	02A0
33.35	704	02C0
36.81	736	02E0
40.65	768	0300
45.16	800	0320
50.24	832	0340
56.14	864	0360
63.29	896	0380
71.68	928	03A0
82.08	960	03C0
96.27	992	03E0
119.94	1024	0400

- Focal length values in the above table are not based on actual measurements or adjustments, but only reference values as a guide. Please adjust the angle of view settings accordingly while viewing the actual image.

6. Dimensions

6.1. Camera Dimensions

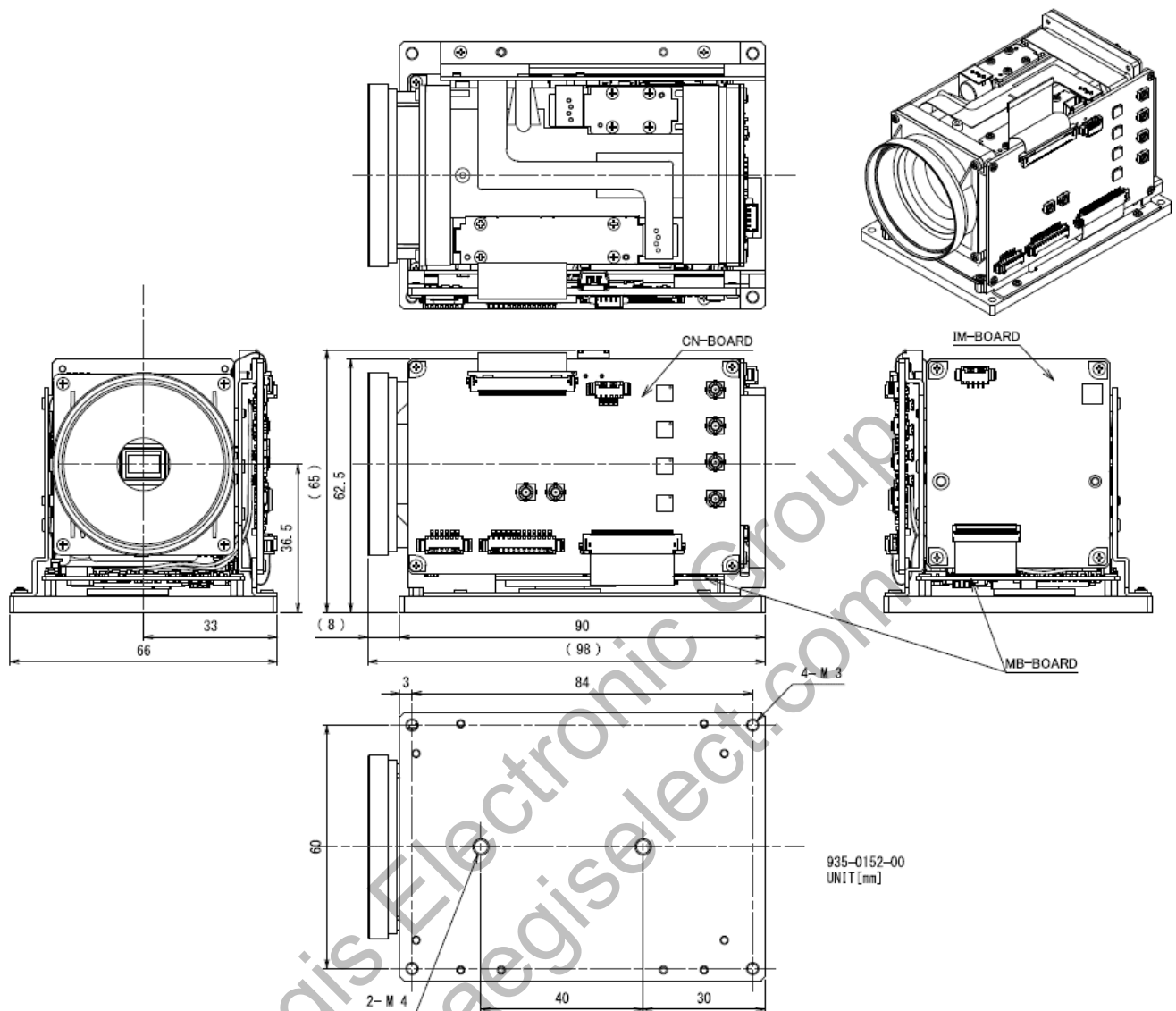

[Note]

※1). Attach the base plate to a heat dissipation component to dissipate the heat generated by the camera sufficiently before use.

※2). Use M3 screw holes on the four corners of the base to mount the camera module to your chassis or heat dissipation materials. If you use M4 screw holes (2 positions) on the center axis of the base to mount, select and adjust the fixing screws so that the height of the screws that penetrate or protrude from the base of the main unit is less than 1 mm. Please refer to the drawing below. If the fixing screw protrudes more than 1 mm from the base, it may contact or interfere with the board, resulting in failure.

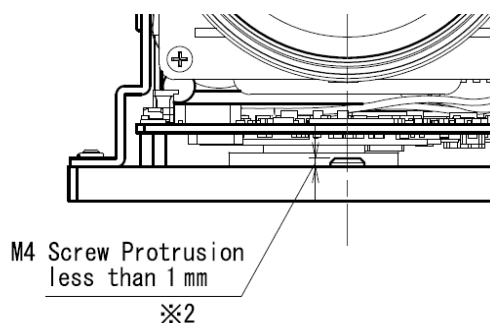

7. Case for Indemnity (Limited Warranty)

7.1. Product Warranty

The warranty period for this product is 1.5 years from the date of shipment from our factory.

During this period, if a failure occurs due to our design or manufacturing, CIS Corporation, at its option, repairs or replaces free of charge. However, the warranty does not cover damage or malfunction caused by negligence in handling by the customer, or damage or malfunction caused by fire, earthquake, lightning, windstorm, flood, or other acts of God or force majeure. Repair after the warranty period is subject to charge.

CIS should not hold responsible for damages or losses if;

- damages or losses are caused by earthquake, lightning strike, fire, flood, or other acts of God.
- damages or losses are caused by deliberate or accidental misuse by user, or failure to observe the information contained in the instructions in this Product Specification and Operational Manual.
- damages or losses are caused by repair or modification conducted by customer or any unauthorized party.
-

7.2. CMOS Defective Pixels

CIS applies defective pixel correction prior to the shipment of the product. However, the number of defective pixels is subject to increase due primarily to the effect of cosmic rays. Due to this nature, CIS should not hold responsible for the natural increase of defective pixels.

8. Product Support

Should you have any problems in function of the product you purchased, and if you need our further analysis and/or repair, please contact your local distributor.