

CIS

English

CoaXPress I/F
1.3M CMOS B/W Camera

VCC-SXCXP3M

Product Specifications & Operational Manual

CIS Corporation

©2017 CIS Corporation. All rights reserved.

Table of Contents

	PAGE
1. Handling Precautions	3
2. Product Outline	3
3. Bundled Items	3
3.1. Standard Bundled Items	3
3.2. Packaging.....	3
4. Specifications	4
4.1 General Specifications	4
4.2 Camera Output Signal Specifications	5
4.3 Spectral Response.....	5
5. External Connector Pin Assignment	6
5.1 75Ω BNC Connector	6
5.2 6pins Circular Connector	6
5.3 3pin SIGNAL_OUT Circuit.....	7
5.4 5pin TRIGGER_IN Circuit	7
6. How to Save and Initialize the Settings	7
7. Camera Operational Mode	8
7.1 Link Configuration	8
7.2 Pixel Format	8
7.3 Camera Sync Mode	8
7.3.1 Internal Sync Mode (Free Run Mode)	9
7.3.2 External Trigger Sync Mode	9
8. Function Settings.....	12
8.1 Gain Settings	12
8.2 Shutter	13
8.3 ROI (Region of Interest)	14
8.4 Sub-Sampling	15
8.5 Defective Pixel Correction	15
8.6 Shading Correction.....	16
8.7 Black Level adjustment	16
8.8 Test Pattern.....	17
8.9 LED Indicator	17
8.10 Camera Timing Output.....	18
8.11 Device User ID	18
9. Sequence Control Function	19
9.1 Basic Operation	19
9.2 Trigger Mode Operation and Burst Mode Operation Outline.....	20
9.3 Trigger Mode	21
9.4 Burst Mode	22
9.5 Index Mode.....	23
9.6 Settings for Sequence Control.....	24
9.7 Sequence Status Information.....	25
10. Factory Settings	26
11. Dimensions	27
11.1 Optical Axis Accuracy.....	27
11.2 Camera Dimensions.....	28

12. Case for Indemnity (Limited Warranty)	29
13. Product Support	29

Aegis Electronic Group
www.aegiselect.com

1. Handling Precautions

The camera module must not be used for any nuclear equipment or aerospace equipment with which mechanical failure or malfunction could result in serious bodily injury or loss of human life. Our warranty does not apply to damages or defects caused by irregular and/or abnormal use of the product.

All specifications contained herein are subject to change without prior notice. Reproduction in whole or in part is prohibited.

Please observe all warnings and cautions stated below.

Our warranty does not apply to damages or malfunctions caused by neglecting these precautions.

- Do not use or store the camera module in the dusty or humid places.
- Do not apply excessive force, vibration, or static electricity that could damage the camera. Handle the camera with caution.
- Do not shoot direct images that are extremely bright (e.g., light source, sun, etc). When extremely strong light source is shot, smear or blooming may occur. When the camera is not in use, please put the protection cap on.
- Follow the instructions in Chapter 5, "External Connector Pin Assignment" for connecting the camera module. Improper connection may cause damages not only to the camera module but also to the connected devices.
- Confirm the mutual ground potential carefully and then connect the camera module to monitors or computers. AC leaks from the connected devices may cause damages or destroy the camera module.
- Do not apply excessive voltage. (Use only the specified voltage.) Unstable or improper power supply voltage may cause damages or malfunction of the camera assembly.
- Do not disassemble the camera. The camera once disassembled shall be out of warranty.

2. Product Outline

VCC-SXCXP3M is a CoaXPress interfaced small B/W camera utilizing a 1/2 type, 1.3M pixels CMOS image sensor.

Features

- 29mm x 29mm x 29mm cubic in size
- Global shutter CMOS (Monochrome)
- CoaXPress CXP-1, CXP-2, and CXP-3 x 1 for each
- High speed frame rate: 168fps (at CXP-3 ROI OFF).
- The maximum cable length: Approx. 100m (at CXP-1).
- ROI
- Sub-sampling
- Exposure, Gain settings
- External trigger mode (Fixed trigger shutter mode / Pulse width trigger shutter mode)
- Sequence control function
- Shading correction
- GenICam complied

3. Bundled Items

3.1. Standard Bundled Items

- Camera module, VCC-SXCXP3M
- C mount cap seal

3.2. Packaging

- Individual carton
- Master carton (10pcs/carton)

Note) Q'ty per master carton may vary depends on the shipping q'ty.

4. Specifications

4.1 General Specifications

(1) Image sensor	Device type	1/2 type Global shutter CMOS		
	Effective pixel numbers	1280(H) × 1024(V)		
	Unit cell size	4.8μm(H) × 4.8μm(V)		
(2) Video output frequency	Pixel clock	72MHz		
(3) CoaXPress	Ver. 1.0 complied. CXP3 / CXP2 / CXP1 x1 each			
(4) Video output format	Mono 8 / Mono 10			
(5) Resolution	1024 TV lines			
(6) Output (sensor AD)	10bit			
(7) Sensitivity	F2.8 400 lx (Shutter 1/300(s), Gain 0dB)			
(8) Minimum illumination	F1.4 0.98 lx (Shutter 1/300(s), Gain 18dB)			
(9) Defective pixels correction	Corrected at Ex-factory			
(10) Gain variable range	x 1 ~ x32 (0dB – 30dB)			
(11) Shutter	Global shutter			
(12) Shutter speed	Preset : 1/10000, 1/5000, 1/2500, 1/1200, 1/600, 1/300, 1/150, 1/100 [s] Manual : 100[us] ~ approx. 1/Frame rate			
(13) Gamma correction	1 fixed			
(14) Trigger mode	Free run mode (Camera internal trigger) Trigger mode <ul style="list-style-type: none"> · Preset shutter trigger · Pulse width shutter trigger 			
(15) Partial scan (ROI)	5 Preset patterns (Quad-VGA, 1K1K, XGA, SVGA, VGA)			
(16) Power requirements	PoCXP			
(17) Power consumption	2.5W (CXP-1), 2.7 W (CXP-2, CXP-3), [entire pixels at free run]			
(18) Dimensions	H:29mm W:29mm D:29mm ※without protruding portion			
(19) Weight	Approx. 50 g			
(20) Lens mount	C mount			
(21) Safety/Quality standards	UL: Conform to UL Standard including materials and others.			
	EMC: 2014/30/EU			
	CE: EN61000-6-4:2007+A1:2011 for Emission EN61000-6-2:2005 for Immunity			
	RoHS: 2011/65/EU Conform to EN50581 (RoHS2).			
(22) Durability	Vibration	Acceleration	98m/s ² (10G)	
		Frequency	20~200 Hz	
		Direction	X,Y, and Z 3 directions	
		Testing time	120 minutes for each direction	
	Shock	No malfunction shall be occurred with 980m/s ² (100G) for ±X,±Y, and ±Z, 6 directions. (Without packaging)		
(23) Operation environment	Performance guaranteed	0 ~ +40°C	Humidity 20 ~ 80%RH	with no condensation
	Operation guaranteed	-5 ~ +45°C	Humidity 20 ~ 80%RH	with no condensation
	※Performance guaranteed: All the specifications specified in this manual is guaranteed under performance guaranteed temperature.			
	※Operation guaranteed: All the camera functions operate normally under operation guaranteed temperature.			
(24) Storage environment	Storage temperature: -25 ~ +60°C, Humidity: 20 ~ 80% RH with no condensation.			

4.2 Camera Output Signal Specifications

(1) Video output data	Maximum effective video output	1280(H) × 1024(V)	
(2) Image signal output	BNC Connector LINK 0	PoCXP	Superimposed Signals of Power, Video, and Control signals
(3) Tap output	Tap geometry	1X-1Y	
(4) Video signals output level	White clip level	FFh	At MONO 8bit
	Setup level	01±01h	At MONO 8bit, Gain 0dB
	※Setup level changes when gain is increased. It is adjustable by changing black level, or Black Off set.		
(5) External trigger signal input	CoaXPress BNC connector	Low speed uplink	20.83Mbps
	6 pins round connector Pin No.5	TTL input	DC5V (Max 5.5 V)
(6) General signal output	6 pins round connector Pin No.3	EXPOSURE, FVAL, LVAL, Uplink Trigger (After decode)	With register settings, 1 can be output. 5V output

4.3 Spectral Response

- ※ The lens characteristic and the illuminant characteristics are excluded.
- ※ Please refer to the data for Mono below.

Quantum Efficiency

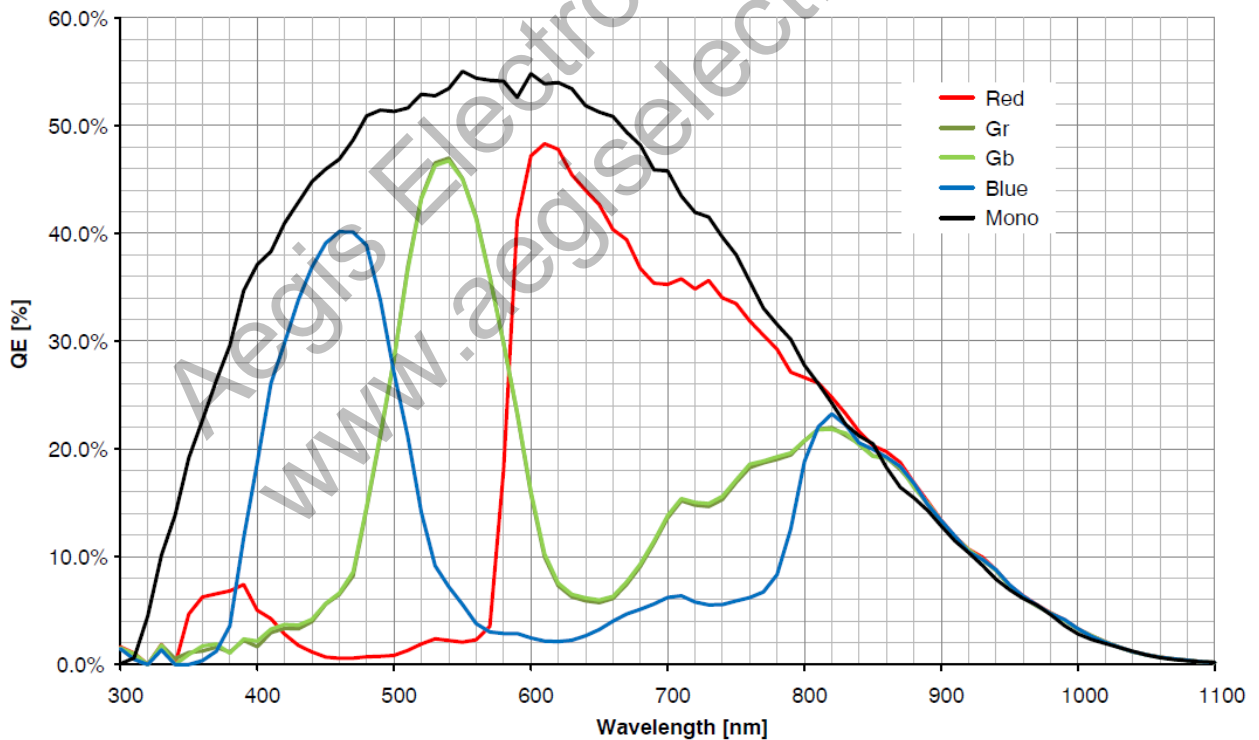

5. External Connector Pin Assignment

5.1 75Ω BNC Connector

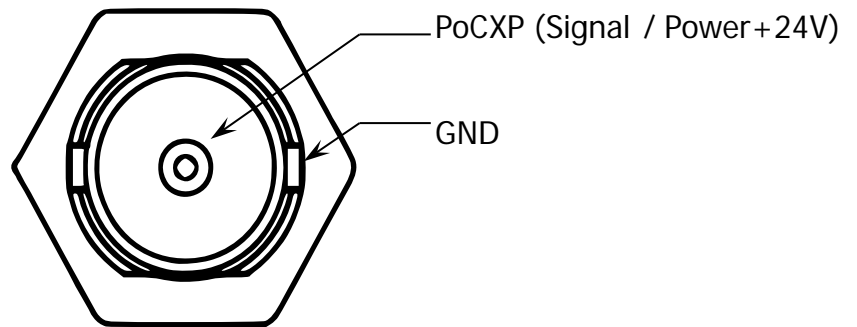

(BNC 0V104C00: Japan Aviation Electronics Industry, Limited)

5.2 6pins Circular Connector

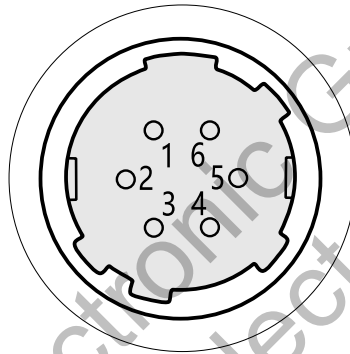

(SNH-8-6(RPCB) SamWoo Electronics)

Pin No.	Signals	Note
1	NC	
2	NC	
3	SIGNAL_OUT	The output of the selected signal
4	NC	
5	TRIGGER_IN	Trigger input
6	GND	Conduction with camera casing

※NC means Non-Connection. Do not connect anything to the terminal.

5.3 3pin SIGNAL_OUT Circuit

- Camera internal timing signals can be output. Set the signal to output from Line Source of Digital IO Control. Please refer to the Section 8, for the details.
- 5.0V CMOS logic level output
- Output voltage Low: 0.55Vdc (Max), High: 3.8Vdc (Min)

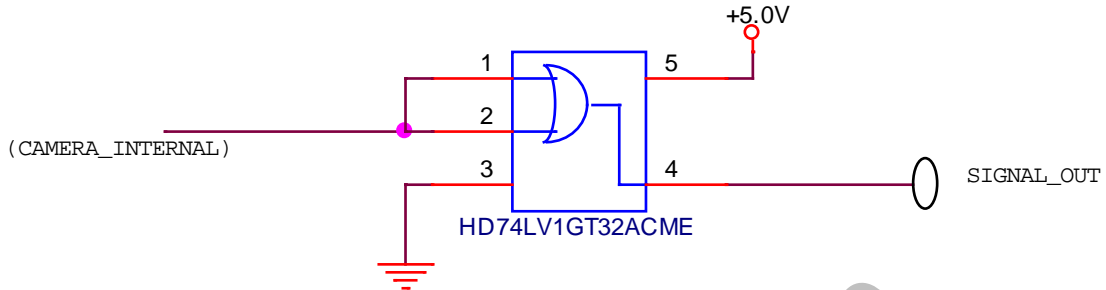

5.4 5pin TRIGGER_IN Circuit

- Trigger signals can be input directly into the camera from external equipments. When you use this terminal, set TriggerSource of Acquisition Control to LineIn. Please refer to the Section 7, for the details.
- 5.0V, 3.3V CMOS level input (TTL compatible)
- Input voltage Low: 0.5Vdc(Min), High: 2.1Vdc(Max)

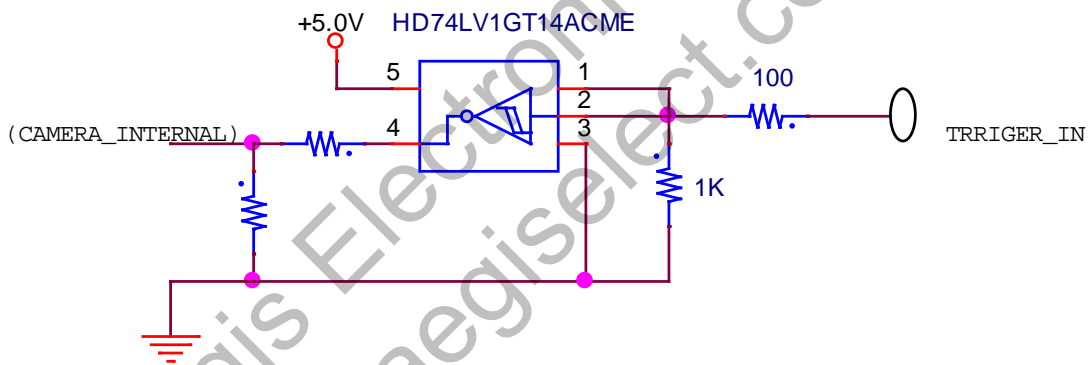

6. How to Save and Initialize the Settings

UserSetControl	
UserSetSave	Execute
UserSetDefault	Execute

Settings shall be restored to the initial settings when UserSetDefault is executed. This can be done only when Link Configuration is CXP-1 (CxpLinkConfiguration). Unless otherwise UserSetSave is executed, data cannot be saved. If you wish to save the setting values, execute UserSetSave. Doing so, the setting values shall be saved in the camera internal ROM. Even when the camera power is turned OFF, the saved settings shall be reflected when the camera is turned on next time.

7. Camera Operational Mode

7.1 Link Configuration

Transfer Control	
CxpLinkConfiguration	CXP1_X1 CXP2_X1 CXP3_X1

7.2 Pixel Format

ImageFormatControl	
PixelFormat	MONO8 MONO10

7.3 Camera Sync Mode

Acquisition Control	
TriggerSelectorAndActivation	AcquisitionMode FrameStartRisingEdge FrameStartFallingEdge FrameStartLevelHigh FrameStartLevelLow FrameBurstStart
TriggerSource	LinkTrigger0 Line0
TriggerSoftware	(Execute)

- TriggerSelectorAndActivation
 - AcquisitionMode : Internal sync mode (Free run mode)
 - FrameStartRisingEdge : External trigger sync mode (Fixed trigger shutter mode: rising edge)
 - FrameStartFallingEdge : External trigger sync mode (Fixed trigger shutter mode: falling edge)
 - FrameStartLevelHigh : External trigger sync mode (Pulse width trigger shutter mode: High active)
 - FrameStartLevelLow : External trigger sync mode (Pulse width trigger shutter mode: Low active)
 - FrameBurstStart : Internal sync mode (Burst mode of sequence function)

- TriggerSource

This is to set how to input triggers of external trigger sync mode.

LinkTrigger0: This is to use Low Speed uplink of CoaXPress to input triggers via coaxial cable connected to a frame grabber board.

Line0: This is to input triggers via No. 5 pin of the 6pin circular connector of the camera rear.

- TriggerSoftware

This command is to generate a trigger in the camera and capture image for 1 frame. Please note that the trigger timing is not so accurate like the one generated by TriggerSource. The Acquisition Control mode which can be used are only TriggerSelectorAndActivation --- FrameStartRisingEdge mode.

7.3.1 Internal Sync Mode (Free Run Mode)

This is a mode to use triggers continuously made in the camera. No external trigger shall be used.

- Set TriggerSelectorAndActivation to AcquisitionMode.

Link Configuration	Frame rate (fps)	
	8bit	10bit
CXP-1	84.0	67.7
CXP-2	167.8	135.5
CXP-3	167.8	167.8

7.3.2 External Trigger Sync Mode

This is a mode to input external trigger signals to capture images by any preferred timings.

Some delay shall be considered from when camera recognized the trigger edge to when actual exposure starts.

Please refer to the delay time as below.

TriggerSource	Delay Time
LinkTrigger0	Approx. 3.4 μ s
Line0	Approx. 150ns

- Notes for trigger pulse input timing

The next trigger pulse can be input while reading out signals. However, please do not input a trigger pulse which ends its exposure while reading out the prior signals. In other words, a trigger pulse, while reading out signals for the prior frame and starts reading out signals for the next frame, cannot be input.

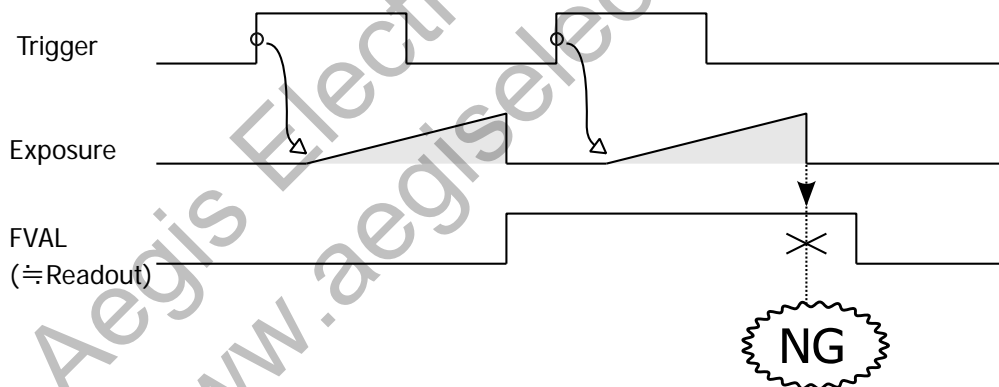

When a trigger is input with the restricted timing explained the above, or with the timing to end exposure right after FVAL becomes "L", video output from the camera might be stopped. In such case or when proper image data cannot be output, execute "SensorReset" command after trigger input is stopped to re-start camera operation.

- ※ In case of when camera does not start operating, please reboot the camera.

Device Control	
SensorReset	(Execute)

- Notes for the delay time between trigger pulse and exposure start

Due to image sensor's own characteristics, the timing, for standard operation and overlapped operation, from when a trigger is input to the image sensor to when the actual exposure starts, would be different. With standard operation, the exposure for the next frame starts after completion of reading out the prior frame. With overlapped operation, the next exposure starts while reading out the prior frame.

	CXP1	CXP2	CXP3
Exposure Delay [μ s] For Standard operation *Timing chart: Exposure delay time (A)	7	7	7
Exposure Delay [μ s] For overlapped operation *Timing chart:Exposure delay time (B)	62-72	31-36	31-36

* The variable range of delay time is determined by the settings of frame rate and exposure time. Under the certain conditions, it does not change randomly.

7.3.2.1. Fixed Trigger Shutter Mode

This is the mode to start exposure by the input trigger signals, and to set its exposure time manually or with preset.

- Set "TriggerSelectorAndActivation" to "FrameStartRisingEdge" or "FrameStartFallingEdge".
- Trigger cycle needs to be longer than FVAL period ($\approx 1/\text{frame rate}$).
- Trigger cycle needs to be longer than the exposure time.
- Trigger operation is CLK Sync HV sync. reset.
- Trigger pulse width to be input shall be over 30us.
- The maximum exposure time depends on ROI setting, "PixelFormat", and Link configuration.

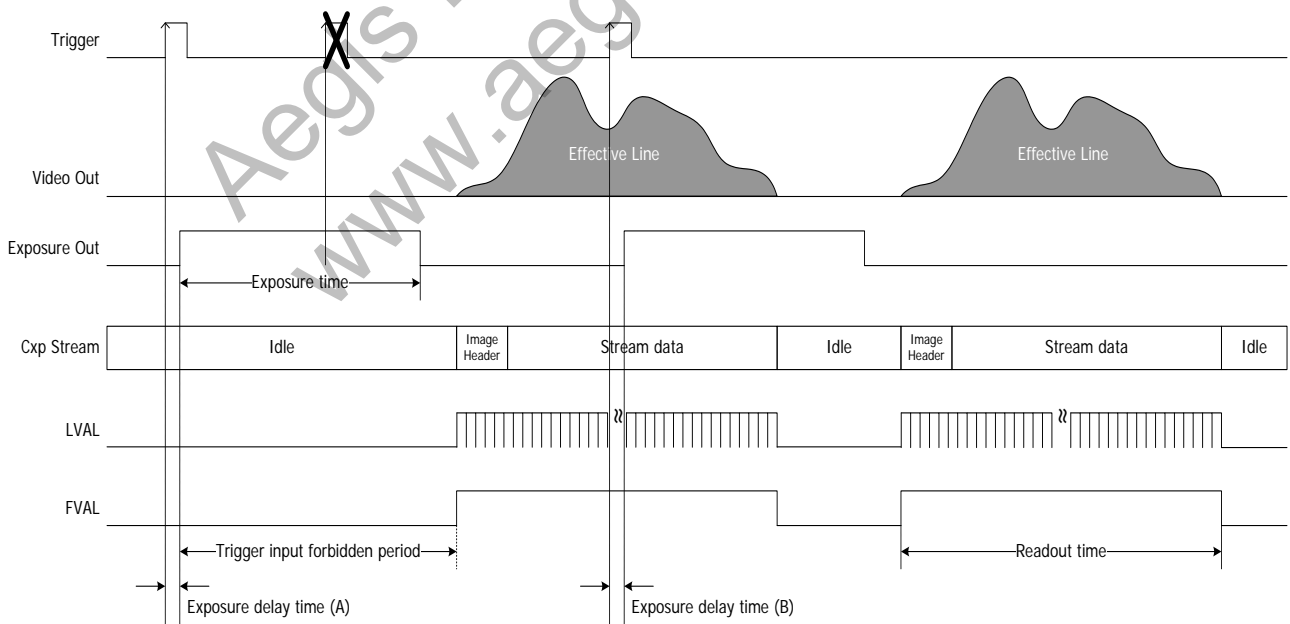

7.3.2.2. Pulse Width Trigger Shutter Mode

This is the mode to start exposure by the input trigger signals, and to set its exposure time with trigger pulse width.

- Set "TriggerSelectorAndActivation" to "FrameStartLevelHigh" or "FrameStartLevelLow".
- Trigger cycle needs to be longer than FVAL period ($\cong 1/\text{frame rate}$).
- Trigger operation is CLK Sync H-V Sync Reset.
- The minimum pulse width shall be 100 μs .
- Functionally, there is no upper or lower limitation. However, at long exposure, some noises, lines, pixel-wise FPN, and shading might be noticeable.

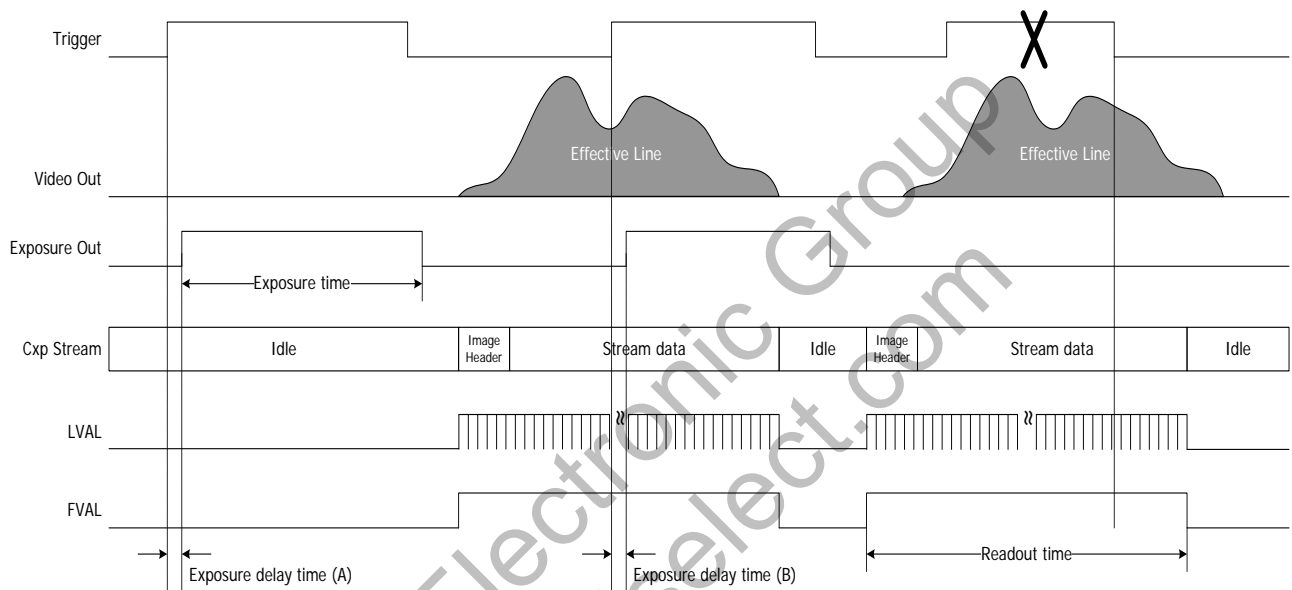

8. Function Settings

8.1 Gain Settings

This is to increase the video out level with the preset gain or manual gain. The setting values are powered values.

※Functionally, gain up function is up to +32 times. However, the image quality will be reduced when gain setting is increased. We recommend you to evaluate it first.

AnalogControl	
PresetGainX	Gain_x1
	Gain_x1_5
	Gain_x2
	Gain_x3
	Gain_x4
	Gain_x6
	Gain_x8
Gain	(Manual)

- Preset gain (GainMode)

When a preset value is set, it will be reflected to manual setting gain.

PresetGainX	Magnification	Decibel equivalent
Gain_x1	x1	0dB
Gain_x1_5	x1.5	3.5dB
Gain_x2	x2	6dB
Gain_x3	x3	9.5dB
Gain_x4	x4	12dB
Gain_x6	x6	15.6dB
Gain_x8	x8	18dB

- Manual gain (Gain)

Any preferred values from x1 to x32 can be set per x0.25.

8.2 Shutter

Exposure time can be set. There are two ways to set, with preset value, and with inputting the value manually.

Acquisition Control	
PresetShutter1_Xs	Shutter_1_100
	Shutter_1_150
	Shutter_1_300
	Shutter_1_600
	Shutter_1_1200
	Shutter_1_2500
	Shutter_1_5000
	Shutter_1_10000
ExposureTime	(Manual)

- **PresetShutter1_Xs : Preset Shutter Mode**
When a preset value is set, it shall be reflected to the manual setting of Exposure Time. According to the image size (ROI) and frame rate, execution would be limited.

PresetShutter1_Xs	Shutter(s)	Time
Shutter_1_100	1/100	10ms
Shutter_1_150	1/150	6.7 ms
Shutter_1_300	1/300	3.3 ms
Shutter_1_600	1/600	1.7 ms
Shutter_1_1200	1/1200	833 us
Shutter_1_2500	1/2500	400 us
Shutter_1_5000	1/5000	200 us
Shutter_1_10000	1/10000	100 us

- **Exposure Time: Manual Shutter Mode**
According to video output format, link configuration, and ROI settings, the maximum exposure time would be limited. Please refer to the chart below.

(Unit: μ s)

	8Bit			10Bit		
	CXP1	CXP2	CXP3	CXP1	CXP2	CXP3
ROIQuickChangeOff	11624	5713	5713	14521	7140	5713
ROIQuickChangePattern1	10916	5352	5352	13640	6699	5352
ROIQuickChangePattern2	9828	4804	4804	11695	6152	4804
ROIQuickChangePattern3	7428	3595	3595	8865	4313	3595
ROIQuickChangePattern4	4936	2347	2347	5540	2649	2347
ROIQuickChangePattern5	3478	1622	1622	3649	1704	1622

	8Bit			10Bit		
	CXP1	CXP2	CXP3	CXP1	CXP2	CXP3
Subsampling	3460	1630	1580	3640	1720	1630

8.3 ROI (Region of Interest)

This is the mode to increase its frame rate by cutting out and reducing the read out area. One area out of 5 patterns can be selected.

ImageFormatControl
ROIQuickChangePattern1-5
ROIQuickChangeOff

- This mode cannot be used with sub-sampling mode.
- Execute re-grabbing the viewer to acquire images.
- There might be a possibility that pale horizontal noise become noticeable on the image at the completion of exposure of the image sensor, according to ROI mode and exposure timing.

Setting mode	Pixels	Known as	Frame rate(fps)			
				CXP-1	CXP-2	CXP-3
ROIQuickChangeOff	1280x1024	SXGA	8bit	84.0	167.8	167.8
			10bi	67.7	135.5	167.8
ROIQuickChangePattern1	1280x960	Quad-VGA	8bit	89.6	178.7	178.7
			10bi	72.0	144.1	178.7
ROIQuickChangePattern2	1024x1024	1M	8bit	99.3	198.1	198.1
			10bi	83.8	167.4	198.1
ROIQuickChangePattern3	1024x768	XGA	8bit	130.4	260.7	260.7
			10bi	109.8	219.6	260.7
ROIQuickChangePattern4	800x600	SVGA	8bit	193.2	386.3	386.3
			10bi	173.0	345.9	386.3
ROIQuickChangePattern5	640x480	VGA	8bit	268.9	536.7	536.7
			10bi	257.1	514.2	536.7

- The following information for the selected ROI area can be read out.

ImageFormatControl
Width
Height
OffsetX
OffsetY

- ROI area is the centered cut of the image sensor.

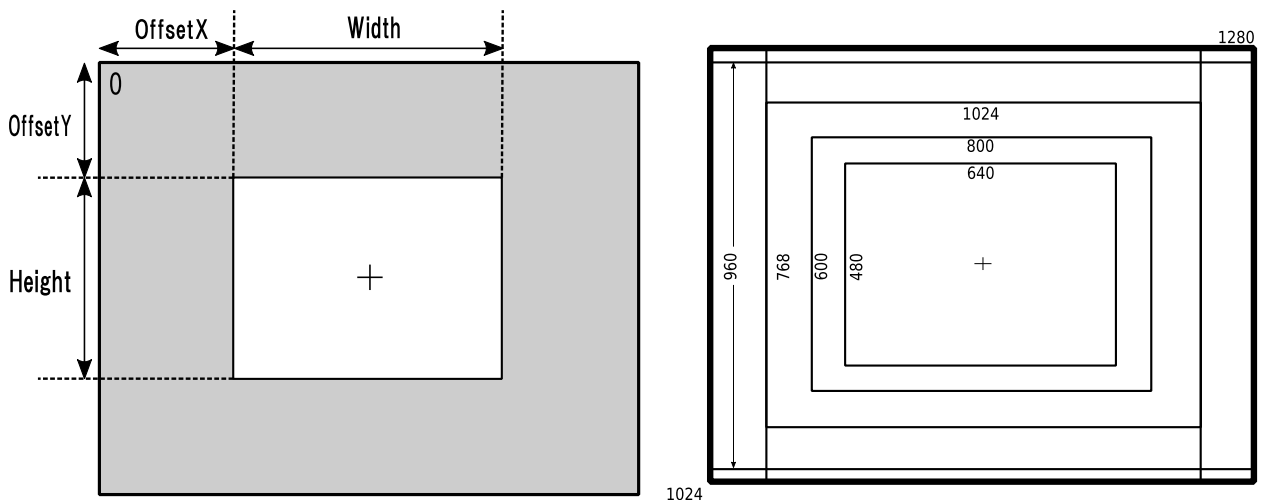

8.4 Sub-Sampling

This is the mode to increase its frame rate by reducing the pixel numbers to read out, reducing both horizontal and vertical pixel number in half, that is, 1/4 of the entire pixels. The field angle remains the same as the one for full resolution.

ImageFormatControl	
SubsamplingMode	Subsampling_On
	Subsampling_Off

- This mode cannot be used with ROI mode.
- Execute re-grabbing the viewer to acquire images.
- The frame rate when sub-sampling operation is performed at free run mode shall be as follows.

Link Configuration	Frame rate (fps)	
	8bit	10bit
CXP-1	266.8	254.5
CXP-2	533.7	508.6
CXP-3	533.7	533.7

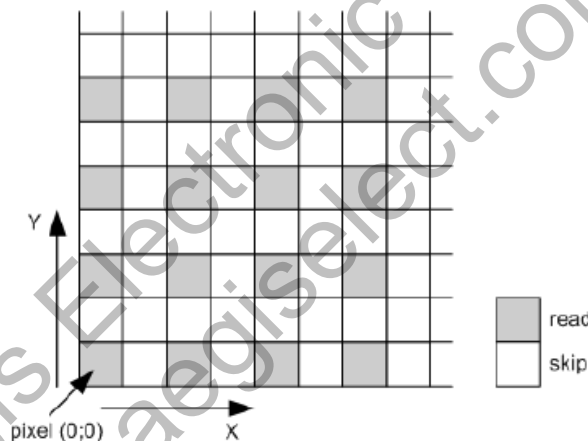

8.5 Defective Pixel Correction

CIS compensates the noticeable CMOS pixel defects found at the shipping inspection prior to our shipment. Defective pixel correction can be set to OFF.

AnalogControl	
DefectivePixelCorrection	True
	False

8.6 Shading Correction

This is a function to correct the peripheral brightness lowering caused by the lens and others used.

AnalogControl	
ShaddingCorrection	True
	False
DetectShading	(Execute)

- Detect Shading

Shoot a uniform object such as a pattern box, to full screen, then execute DetectShading, to calculate and save the correction data automatically in the camera.

* When detecting shading, please make sure that ROI and sub-sampling settings are OFF.

* If DetectShading is executed with no video output at trigger mode operation, it cannot operate properly.

To operate DetectShading properly, a trigger signal shall be input within 200ms after execution.

* When obtain correction data with trigger shutter mode, the data sometimes becomes unstable. In this case, change the trigger cycle in small measure and obtain correction data again.

- Shading Correction

Turn ShadingCorrection ON to start shading correction according to the shading correction data prepared by DetectShading function.

◆ Before Shading Correction

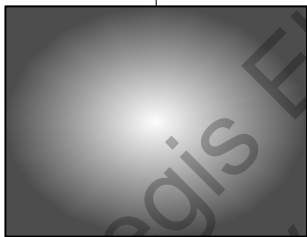

◆ After Shading Correction

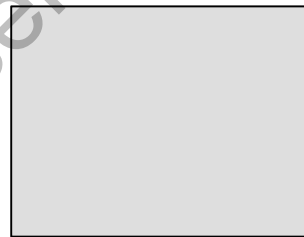

8.7 Black Level adjustment

AnalogControl	
BlackOffset	0~255

- The initial setting value is 20.
- Black level is adjustable with relative values. When it is increased by 1, its luminance level changes by approx. 0.25 at 8 bit output, and it changes by approx. 1.0 at 10 bit output.
- When the lower values than the initial value are set, saturation level would not achieve to the maximum value for output range.

8.8 Test Pattern

AcquisitionControl	
TestImageMode	On/Off

Test pattern can be output from the camera. It is useful to check if your system is operation properly.

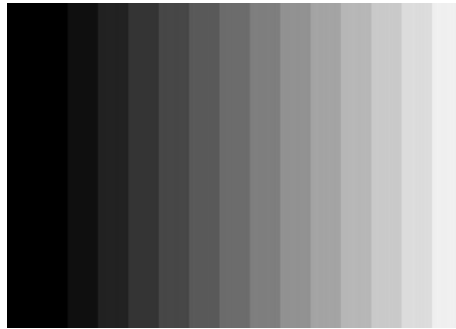

8.9 LED Indicator

Indicator LED

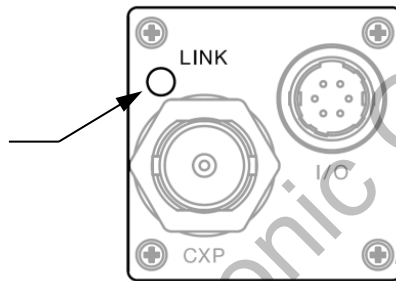

DeviceControl	
DeviceIndicatorMode	Active ErrorStatus Inactive

- Active : Indicate communication status of CoaXPress.
- ErrorStatus : Light only when there was an error in the communication status.
- Inactive : All LED OFF.

Lighting patterns of LED when it is set to active are as follows. It shows the camera status by the way of its lighting.

Lighting Status	Camera Status
OFF	No PoCXP Supplied
Green Slow Blinking [0.5Hz]	Confirmed connection of the device and the host.
Green Lighting	Transmitting video data.
Orange Slow Blinking [1Hz]	Waiting for a trigger input.
Red Fast Blinking	System error occurred.

※ There could be some cases that LED Red blinks to show system error, even though its operation is normal. This can happen if the camera recognized an error in any occasion such as when a trigger was input at the prohibited timing, and when ROI or sub-sampling was changed with keep grabbing video output. This is because error indication status was kept since those errors occurred. To restore this to normal LED lighting status, reboot the camera, or execute Device Control—SensorReset

8.10 Camera Timing Output

According to the settings of LineSource, the following signals can be output from the 6pins circular connector at camera rear.

Digital IO Control	
LineSelector	Line1
LineMode	Output
LineSource	OFF ExposureActive FrameActive LineActive TriggerPacketActive

- LineSource

- ExposureActive : Exposure period of image sensor is to be shown as Hi Active.
- FrameActive : The effective period of the frame is to be shown as Hi Active.
- LineActive : The effective period of the line is to be shown as Hi Active.
- TriggerPacketActive : Uplink trigger packet signals from the frame grabber board is to be decoded and output.

8.11 Device User ID

DeviceControl	
DeviceUserID	[User Defined]

The user defined device name up to 16 characters can be set to the camera. Execute "UserSetSave" to save it to EEPROM in the camera. Execute "UserSetDefault" if you wish to restore it to the factory setting.

※ This is the resister area for up to 16byte. English single byte characters shall be input.

9. Sequence Control Function

This is the function to select one set of parameter out of the several preset parameter sets per every trigger input, and apply it to the camera.

- The maximum 8 kinds of parameter sets can be preset. The following parameters can be set per parameter. Settable parameter: Shutter and Gain.
- Operation sequence is specified as "Index". Specify the parameter set number to be applied for the maximum 8 indexes.
- There are three control modes; trigger mode, burst mode, and index mode.
- For the settable AcquisitionMode (Camera operational mode) and SequenceActivation (Start operation) which correspond to sequence mode, please refer to the below chart.

AcquisitionControl AcquisitionMode [TriggerSelectorAndActivation]						
【Sequence Operational Mode】	FrameStartRisingEdge	FrameStartFallingEdge	FrameStartLevelHigh	FrameStartLevelLow	FrameBurstStart	SequencerControl [SequencerActivation]
Trigger Mode	⊙	⊙	⊙	⊙		FrameStartPredfined
Index Mode	⊙	⊙	⊙	⊙		FrameStartIndexselector
Burst Mode					⊙	FrameBurstStartEdge FrameBurstStartLevel FrameBurstStartSoftware

9.1 Basic Operation

Please set the following operational modes before using sequence control function.

- (1) Settings of AcquisitionControl --- TriggerSelectorAndActivation
This is to set camera operational mode.
- (2) Settings of Sub-sampling and ROI
Turn OFF SubsamplingMode. ROI of ImageFormatControl shall be ROIQuickChangeOff.
These are invalid with sequence control function.
- (3) Settings of parameter table for sequence (SequenceParameterSetSelector)
Set Exposure Time and Gain for each parameter set.
- (4) Settings of parameter set to be used for sequence (ParameterIndexNumber), index loop count (IndexLoopCouunt), whole sequence loop count (SEquenceLoopCount), and index range to be used (ActiveIndexNumber).
- (5) Settings of SequencerControl --- SequencerActivation
This is to set the start operation of sequence mode. By setting preferred SequenceActivation from Off, it will be standing by for a trigger.
- (6) Sequence control operation starts by inputting a trigger to start sequence function.

Note

- Link configuration shall be determined in advance to start each setting.
- Restrictions on trigger input timing for sequence control operation are the same as the one for normal mode.
- SequencerActivation shall be turned OFF once, before setting settings for sequence control.
- With SequencerMode, UserSetSave and UserSetDefault are invalid, therefore, set them after turning power ON. (With other settings for sequence, UserSetSave and UserSetDefault are valid).
- If any triggers had been input to the camera, sequence starts when it is set to other than SequencerActivation OFF. Do not input any triggers when changing SequencerActivation setting.
- For exposure time to input to each parameter set, please refer to the maximum exposure time in the chart of Exposure Time: Manual Shutter Mode, in Section 8.2.
- In case of burst mode, it stops at the last screen when sequence control is completed. And, if a trigger is input then, it operates to capture image for one frame with the last status of the parameter set. To restart burst mode operation, turn OFF SequencerActivation once.
- Turn SequencerActivation OFF to return to the status before sequence control function was operated.

9.2 Trigger Mode Operation and Burst Mode Operation Outline

This is the mode to specify Index transition flow in advance. The repeating count for each Index, the number of the Index to be used, and Loop count can be set.

- Trigger Mode
Index repeat count is increased every time trigger is input externally, and its specified parameter set is applied to the camera.
- Burst Mode
Operation is equivalent to the one for Internal sync mode, free run operation. Sequence starts with the trigger, and Index repeat count is increased with the camera internal trigger, then its specified parameter set is applied to the camera.

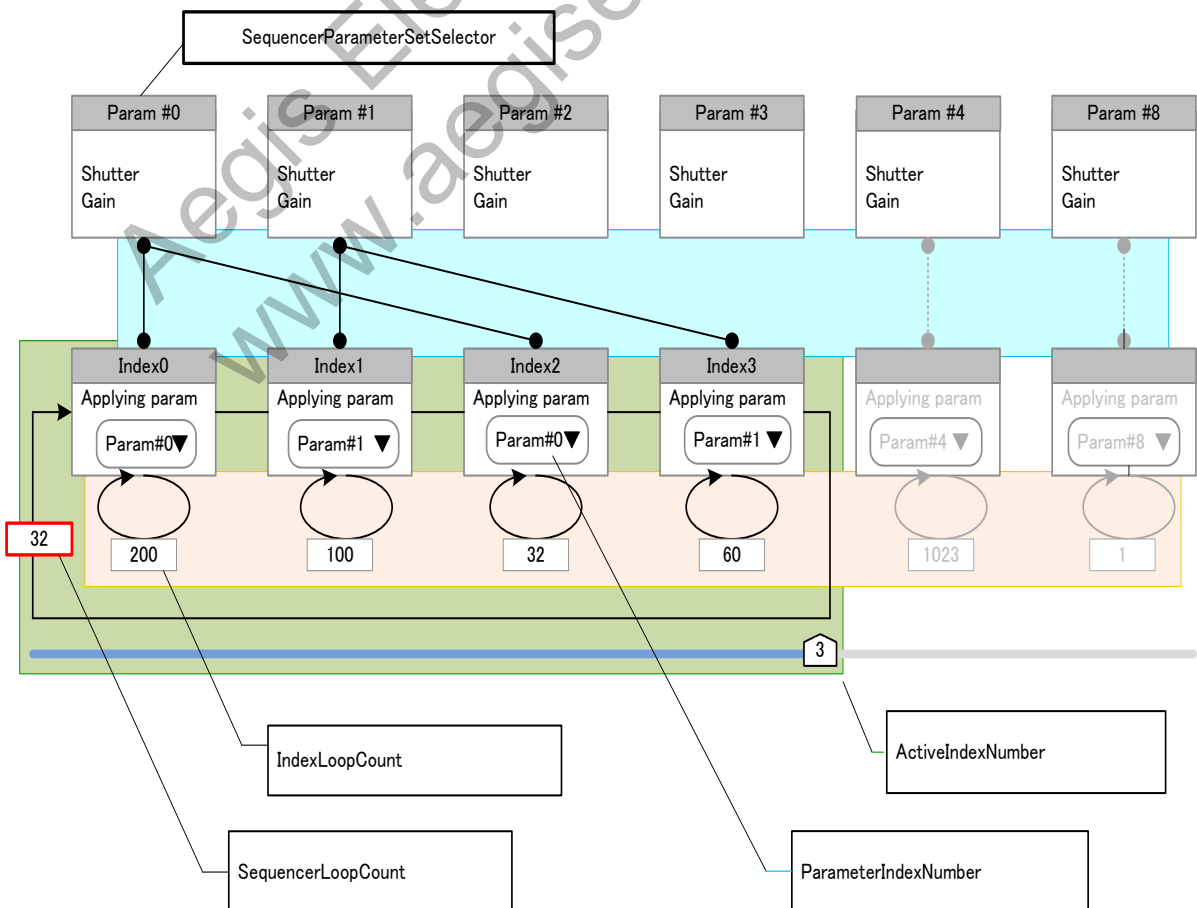

9.3 Trigger Mode

The start and stop of sequence operation can be controlled by the edge control or pulse width control of trigger input signals.

- Set TriggerSelectorAndActivation to the mode to be used out of FrameStartRisingEdge/ FrameStartFallingEdge/ FrameStartLevelHigh/ and FrameStartLevelLow.

(1) Edge Control

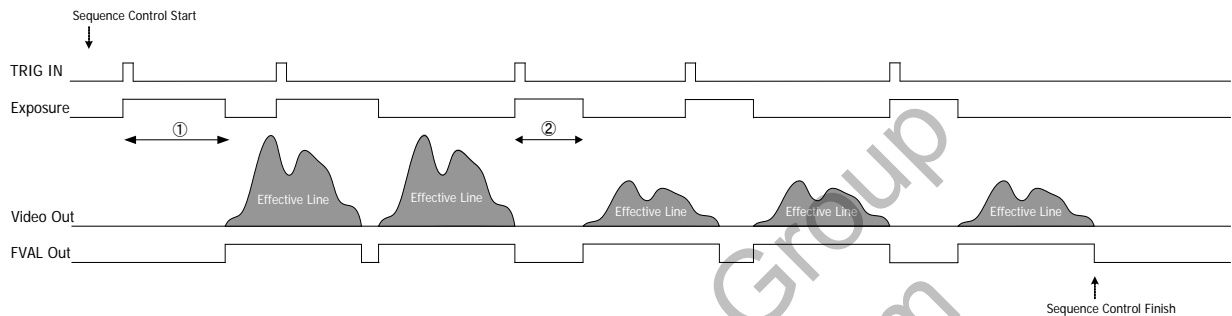

- Sequence starts with trigger input when TriggerSelectorAndActivation is FrameStartRisingEdge or FrameStartFallingEdge.
- Exposure time for each frame (① and ②) shall be controlled by the preset sequence parameter set.
- When the image output for the sequence Loop count is completed, sequence operation ends.

(2) Pulse Width Control

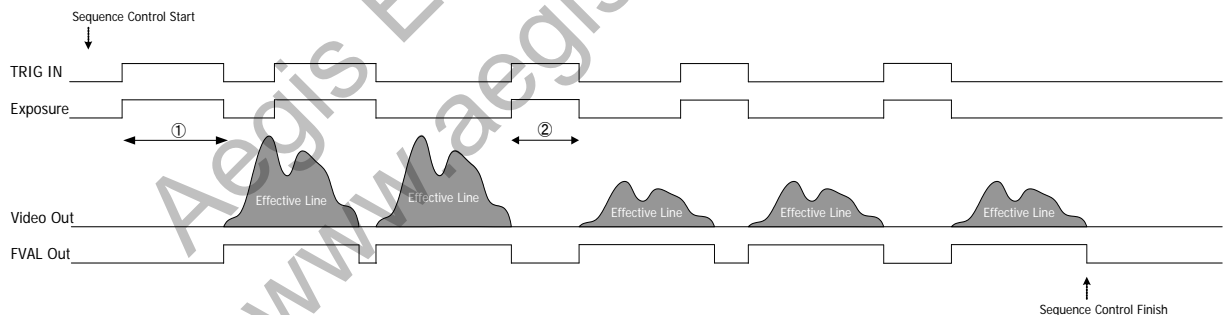

- Sequence starts with trigger input when TriggerSelectorAndActivation is FrameStartLevelHigh or FrameStartLevelLow.
- Exposure time for each frame (① and ②) is the pulse width of the trigger.
- When the image output for the sequence Loop count is completed, sequence operation ends.

9.4 Burst Mode

The start and stop of sequence operation can be controlled by the edge control or level control of trigger input signals, and register start.

- Set TriggerSelectorAndActivation to FrameBurstStart.

(1) Edge Control

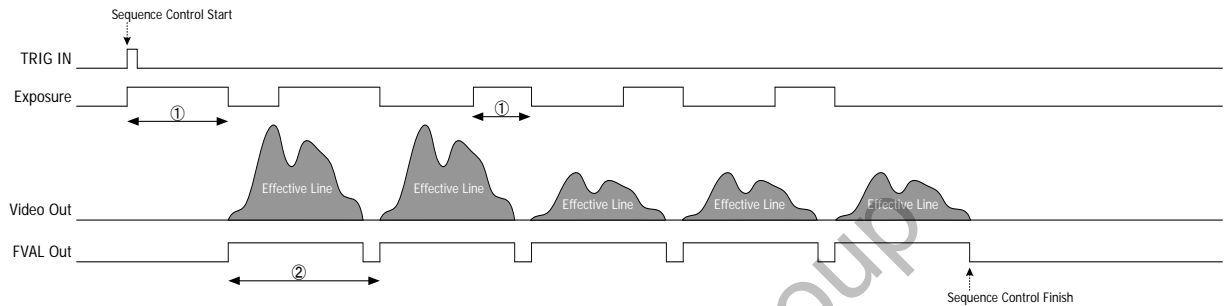

- Set SequencerActivation to FrameBurstStartEdge to start sequence operation by inputting a trigger.
- Exposure time (①) and output frame time (②) for each frame shall be controlled by the preset sequence parameter set and link configuration settings.
- When the image output for the sequence Loop count is completed, sequence operation ends.

(2) High Level Control

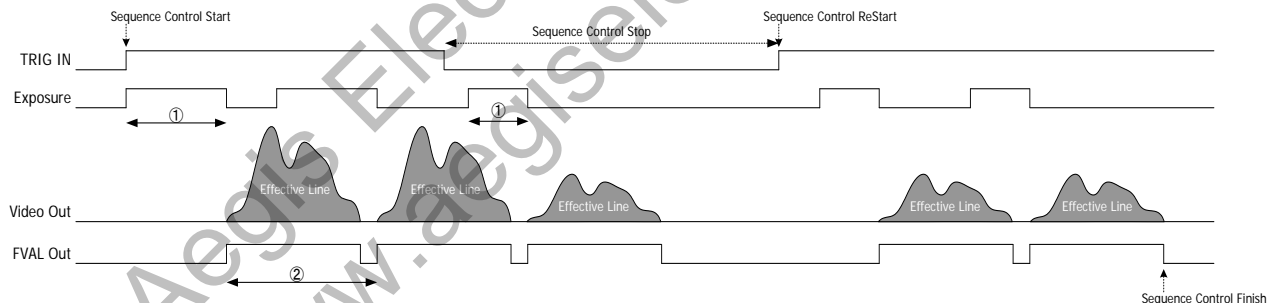

- Set SequencerActivation to FrameBurstStartLevel to start sequence operation while trigger input is at high level.
- Sequence operation can be paused by changing the trigger input to Low level. If you wish to end Sequence operation, turn OFF sequence control.
- By changing the trigger input to High level, Sequence operation can be resumed.
- When the image output for the sequence Loop count is completed, sequence operation ends.

(3) Register Start

- Sequence operation starts at the same time when SequencerActivation is turned off and FrameBurstStartSoftware is set.
 - ※ To restart burst mode operation, turn off SequencerActivation OFF once.

9.5 Index Mode

This is the mode to directly specify the Index number to apply by IndexSelectorModeIndexNumber.

Every time when a trigger is input, the Index parameter set specified by IndexSelectorModeIndexNumber is applied to the camera.

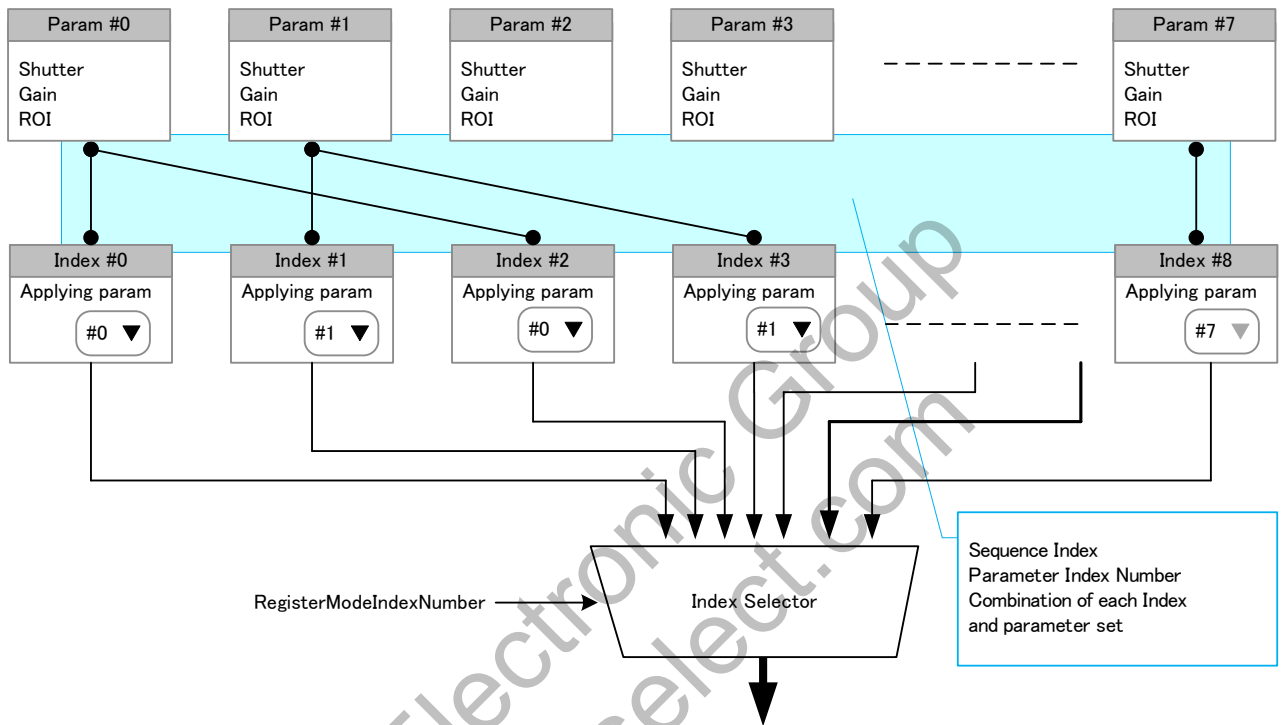

- Set TriggerSelectorAndActivation to the mode to be used out of FrameStartRisingEdge/ FrameStartFallingEdge/ FrameStartLevelHigh/ and FrameStartLevelLow.

(1) Edge Control

- Exposure time for each frame shall be controlled by the preset sequence parameter set.

(2) Pulse Width Control

- Trigger Pulse Width becomes exposure time for each frame. Exposure time of the parameter set is not referred.

- ※ As to the timing to issue IndexSelectorModeIndexNumber command, input a trigger pulse when ACK is responded after IndexSelectorModeIndexNumber is issued, to make sure the specified parameter set is to be reflected to the next frame.

9.6 Settings for Sequence Control

Execute UserSetSave to save the settings. SequencerActivation is not saved so that it will always be OFF when power is turned ON. Settings shall be set every time when using Sequence mode.

- How to set Sequence Control Settings.

Acquisition Control	
TriggerSelectorAndActivation	AcquisitionMode FrameStartRisingEdge FrameStartFallingEdge FrameStartLevelHigh FrameStartLevelLow FrameBurstStart

- FrameStartRisingEdge: Set sequence control to the rising edge control of the trigger pulse.
- FrameStartFallingEdge: Set sequence control to the falling edge control of the trigger pulse.
- FrameStartLevelHigh: Set sequence control to the high level control of the trigger pulse.
- FrameStartLevelLow: Set sequence control to the low level control of the trigger pulse.
- FrameBurstStart: Set sequence control to use at burst mode.

- Settings for Sequence Mode Start

SequencerControl	
SequencerActivation	OFF FrameStartPredefined FrameStartIndexSelector FrameBurstStartEdge FrameBurstStartLevel FrameBurstStartSoftware

- FrameStartPredefined: Set to start trigger mode and burst mode.
- FrameStartIndexSelector: Set to start index mode.
- FrameBurstStartEdge: Set to start burst mode with edge control.
- FrameBurstStartLevel: Set to start burst mode with High level control.
- FrameBurstStartSoftware: Set to start burst mode with register start.

- Settings for Sequence Count and Range

SequencerConfigurationParameter		Setting Range
SequencerLoopCount	Loop count for whole sequence.	1-1023 0: infinite
ActiveIndexNumber	The largest Index number to execute.	0-7
IndexSelectorModeIndexNumber	The Index number to use for Index Mode.	0-7
ParameterIndexNumber		
Index0-7	Parameter number of Index 0-7.	0-7
IndexLoopCount		
IndexCount0-7	Repeating count of each Index 0-7.	0-1023

□ Settings for Sequence Parameter Set

8 parameter sets are prepared. By changing the number of SequencerParameterSetSelector, parameter set will be replaced. Even if the parameter number is changed, the set data will be maintained.

SequencerParameterSetSelector	Parameter Set 0~7	
SetConfiguration		
	SequencerExposureTime	Exposure Time
	SequencerGain	Gain

9.7 Sequence Status Information

This is to indicate the status of Sequence control. The status information is embedded in the effective image area to be output.

SequencerStatus		
SequencerInformationLocation	Specify the position to indicate the status information.	
	Off	Output of status information OFF.
	TopLeft	Upper Left
	TopRight	Upper Right
	BottomLeft	Lower Left
	BottomRight	Lower Right
FrameBurstStatus	Indicate the status information of Sequence burst mode. 0: Executing 1: Completion	
IndexNumberStatus	Indicate the Index number in execution.	
RepeatNumberStatus	Indicate the Index repeating count in execution.	
LoopNumberStatus	Indicate Sequence Loop count in execution. *When loop count is set to infinity, indication shall be up to 1023 loop count.	

The position to indicate the status information can be selected out of four positions as below, and the information is to be embedded into 5 pixels.

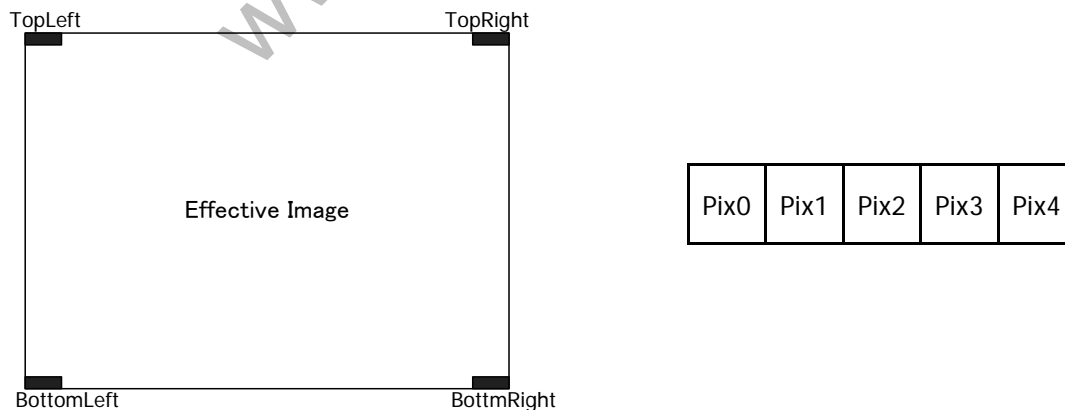

Information on Index number, Index repeating count, and Loop count is output to each pixel as follows.
In case of 10bit video output, 2 bit on LSB side shall be always "00".

	MSB		LSB
pix0	Index Number[3:0]	"0000"	"00"
pix1	Repeating Count [7:0]		"00"
pix2	"000000"	Repeating Count [9:8]	"00"
pix3	Loop Count [7:0]		"00"
pix4	"000000"	Loop Count [9:8]	"00"

10. Factory Settings

DeviceControl		
DeviceUserID	ID00DevU00000000H	
DeviceIndicatorMode	Active	
ImageFormatControl		
SensorWidth	1280(=ROIOff)	
SensorHeight	1024(=ROIOff)	
SubsamplingMode	Subsampling_Off	
PixelFormat	Mono8	
TestImageMode	OFF	
AcquisitionControl		
TriggerSelectorAndActivation	AcquisitionMode	
TriggerSource	LinkTrigger0	
ExposureTime	3333	
AnalogControl		
BlackOffset	20	
Gain	1	
ShadingCorrection	FALSE	
DefectivePixelCorrection	TRUE	
DigitalIOControl		
LineSource	SIGNAL_OFF	
SequencerControl		
SequencerActivation	Off	
SequencerInformationLocation	Off	
Index0~Index7	0~7	The same value as the Index number
Index0Count~Index7Count	1	All 1
SequencerLoopCount	0	
ActiveIndexNumber	0	
ActiveIndexModeIndexNumber	0	
SequencerExposureTime	1000.0	(Selector 0-7)
SequencerGain	1.0	(Selector 0-7)
TransportLayer		
CxpLinkConfiguration	CXP_X1	

※ Factory setting values are the same as the one for UserSetDefault command.

11. Dimensions

11.1 Optical Axis Accuracy

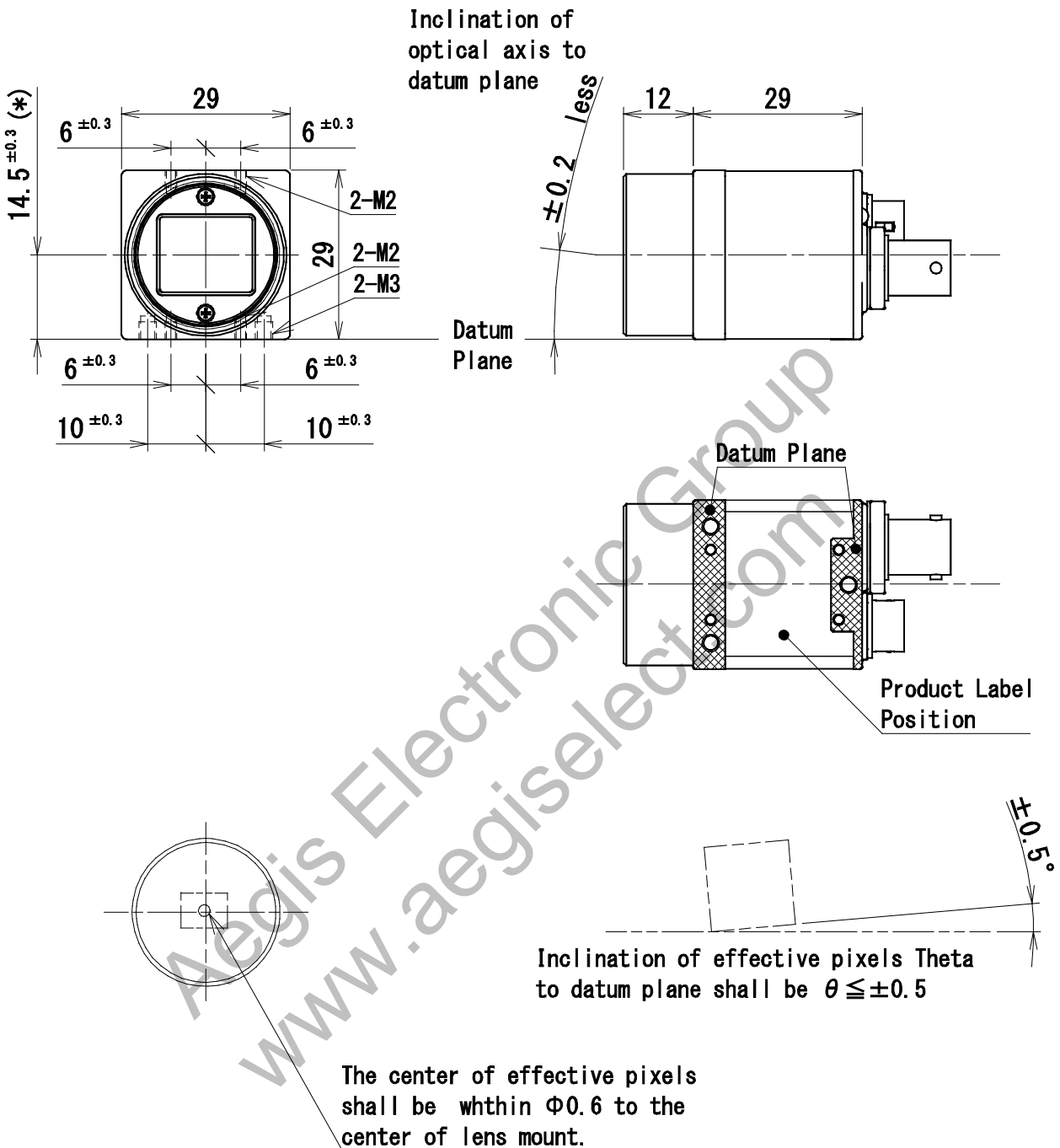

(*)Dimension from datum plane to the center of lens mount.

937-0014-00
(Unit:mm)

12. Case for Indemnity (Limited Warranty)

The term of warranty of this product is within 3 years from the date of shipping out from our factory.

If you use the product properly and discover a defect during the warranty period, and if that was caused by designing or manufacturing, CIS Corporation, at its option, repairs or replaces it at no charge to you. Products out of warranty period will be subject to charge. CIS repairs the products as long as it is repairable.

CIS shall be exempted from taking responsibility and held harmless for damages or losses incurred by the following cases.

- In case damages or losses are caused by earthquake, lightning strike, fire, or other acts of God.
- In case damages or losses are caused by deliberate or accidental misuse by the user, or failure to observe the information contained in the instructions in this Product Specification and Operational Manual.
- In case damages or losses are caused by repair or modification conducted by the customer or any unauthorized party.

• CMOS Pixel Defect

CIS compensates the noticeable CMOS pixel defects found at the shipping inspection prior to our shipment. On very rare occasions, however, CMOS pixel defects might be noted with time of usage of the products. Cause of the CMOS pixel defect is the characteristic phenomenon of CMOS sensor itself and CIS is exempted from taking any responsibilities for them. Should you have any questions on CMOS pixel defects compensation please contact us.

13. Product Support

Should you have any problems in function of the product you purchased, and if you need our further analysis and/or repair, please contact the dealer you purchased it from.