

Messrs.

DATE

19,Jul, 2024

Rev No.

1.0

APPROVAL SHEET

Description	Zoom Camera Series
Model Name	ATC-HZ8940T

Receipt stamp

PRELIMINARY

Issued	Checked	Approved

Revision History

Date	Rev. No	Contents
2024.05.17	1.0	Release Document (preliminary)
2024.07.19	1.0	Actual zoom/focus position (preliminary)

Aegis Electronic Group
www.aegiselect.com

TABLE OF CONTENTS

TABLE OF CONTENTS	-----	3
FEATURES	-----	4
PRECAUTION	-----	5
SPECIFICATIONS	-----	6
DIMENSIONS	-----	9
INTERFACE	-----	10
OSD & MENU	-----	21
FUNCTIONS	-----	24
COMMAND LIST	-----	32

Aegis Electronic Group
www.aegiselect.com

FEATURES

This Product is a high performance CCTV camera with built-in 40x optical zoom and 12x digital zoom technologies. This product can be applied to various fields such as security camera for surveillance (CCTV camera), data viewer, Video presenter(VP) and speed dome camera and industrial applications.

- This camera uses a 1/3.1" 3.20M Global shutter CMOS Image Sensor that supports HD (high definition) to produce high-quality images.
- Using progressive scan, images with a wide dynamic range can be obtained with the newly developed image signal processor (Wide Dynamic Range function, WDR).
- The camera is equipped with a bright zoom lens with 40× optical zoom and F1.6 aperture (optical zoom + digital zoom = 480×)
- Low-noise images can be obtained even in low-light environments using the Noise Reduction function(3DNR/2DNR/2DNR+3DNR)
- Video signals can be output as digital only. Depending on register settings, you can select from a variety of digital output methods: 1080p/60,1080p/50,1080p/30, 1080p/25, 720p/60,720p/50,720p/30, 720p/25, 1080i/50, 1080i/60
- An infrared (IR) Cut-Filter can be disengaged from the image path for increased sensitivity in low light environments. The ICR will automatically engage depending on the ambient light, allowing the camera to be effective in day/night environment.
- A Privacy Zone Masking function (max. 8 blocks) is available.
- A Motion Detection function is available.
- A title composed of up to 17 lines can be set for displaying on the screen. 46 characters can be used on one line (VISCA).

- Support 192 internal zoom/focus presets.
- Digital Image Stabilizer function reduces image blurring caused by vibration.

- Output format

ATC-HZ8940T-LP :

- ▶ LVDS/PARALLEL/CVBS

ATC-HZ8940T-LTA :

- ▶ HD-SDI/EX-SDI(V1.0/V2.0/V2.1/V3.0(TBD))

※3G-SDI output is possible but not guaranteed.

- ▶ LVDS/TVI/AVI/CVBS



ATC-HZ8940T

PRECAUTION

Operation is subject to the following conditions;

- This device may not cause harmful interference.
- This device must accept any interference received, including interference that may cause undesired operation.
- A regulated DC 12V 1A power supply is recommended for use with this camera for the best image and the most stable operation. An unregulated power supply can cause damage to the camera. When unregulated power supply is applied, product warranty will be out of subject.
- If it is used for CVBS application. It is recommended that the camera is used with a monitor that has a CCTV quality 75 Ohm video impedance level. If your monitor is switched to high impedance then please adjust accordingly.
- Do not attempt to disassemble the camera to gain access to the internal components. Refer servicing to your dealer.
- Never face the camera towards the sun or any bright or reflective light, which may cause smear on the image and possible damage to the CMOS.
- Do not remove the serial sticker for the warranty service.
- Do not drop the thing or give a strong impact to the product.
- Avoid the place where is so dusty, humid or soot-covered. It may cause electric shock or fire.
- Do not expose to an intense light source such as direct sunlight or spotlight. It may damage the CMOS.
- If the camera operates more than 24 hours, It is recommended that you execute the lens initial action or reset the camera.

Information may be changed without notice

This document provides technical information for the user. KT&C reserves the right to modify the information in this document as necessary. The customer should make sure that they have the most recent manual version.

SPECIFICATIONS

Format / Model	ATC-HZ8940T-LTA	ATC-HZ8940T-LP		
Video System				
Image Sensor	1/3.1" 3.20M Global shutter CMOS Image Sensor			
Effective Pixels	2064(H)x1552(V), Unit Cell Size(2.25 μm X 2.25 μm)			
Output Format	LVDS/PARALLEL/HD-SDI/CVBS:1080p60/50/30/25, 720p60/50/30/25, 1080i60/50 AVI:1080p30/25 TVI:1080p30/25, 720p60/50/30/25 EX-SDI:1080p60/50/30/25, 720p60/50/30/25 (※ PARALLEL Format is support only LP model)			
Sensor Operating System	Sensor Master			
Sync System	Internal			
CVBS scale	16:9 / 4:3 (CVBS 960H)			
LVDS mode	Single / Dual			
Video Output	CVBS / LVDS			
	HD-SDI / EX-SDI(1.0) / EX-SDI(2.0) / EX-SDI(2.1) / EX-SDI(3.0(TBD)) / HD-TVI / HD-AVI	PARALLEL		
Min. illumination				
Day	T.B.D			
Night (ICR on)	T.B.D			
S/N ratio	More than 52 dB			
Optical Lens				
Zoom Magnification	X40			
Focal Length	4.25 to 170 mm			
Horizontal-Angle	52.87°(W) ~ 1.48°(T)			
Vertical Angle	30.93°(W) ~ 0.85°(T)			
F-value	F1.6(W) ~ F4.95(T)			
Zoom				
Maximum Zoom Ratio	x1 ~ x480			
Optical Zoom Ratio	x1 ~ x40			
Digital Zoom Ratio	x1 ~ x12			
Digital Pan/Tilt	-			
Speed (Focus Tracking On)	3.96 ~ 95.09 sec			
(Focus Tracking Off)	2.8 sec			
Focus				
Control Mode	Auto / Interval / One Shot(=Zoom Trigger, One Push) / Manual / Preset			
Focal Range	Infinity~ 3m(T)~0.01m(W)			
IR correction	Standard/IR Light/user -20~+20			
Day & Night				
D&N mode	Auto / Color (Day) / B&W (Night) / EXT-H / EXT-L			
White Balance	Auto / Indoor / Outdoor / One Push / ATW / Manual			
Exposure				
AE mode	Auto / Iris Priority / Shutter Priority / Manual			
Brightness (Exp.Comp)	1~20			
AGC Max	0FF~48dB			
Manual Shutter	1/1,1/2,1/4(3),1/8(6),1/15(12),1/30(25),1/60(50) ~ 1/30000			
Manual AGC	0FF~48dB			

Format / Model	ATC-HZ8940T-LTA	ATC-HZ8940T-LP		
Exposure				
Manual Iris	F1.6 ~ F19, Close			
Sens-Up	Off ~ 32fields			
ETC	Slow AE response			
DSP functions				
Digital Slow Shutter	Max. 32 fields			
Image Freeze	Off / On			
Image Reverse (E-FLIP)	Off / Horizontal(mirror) / Vertical / H+V(180° flip)			
Privacy Masking	Spherical Privacy			
	- 8-zone			
	- Interlock / Non-Interlock Mask			
	- 14 mask color selectable, semi-transparency			
	- Pan(0°~360°), Tilt(+90°~-90°)			
Title Display	16 characters (display position selectable)			
Motion Detect	4-Zone			
	- Alarm output : OSD / Serial Communication			
D-WDR	Off/ Low/Middle/High			
WDR	WDR (Low/Middle/High)			
BLC	Off / 0 ~ 10, Area selectable			
HLC	Off / 0 ~ 20, Color selectable			
AGC	Max.48dB			
Sharpness	Adjustable(0~15)			
3DNR	OFF/Auto(Level:0~2)/Manual(Gain:0~255/THLD:0~255/EK:0~255)			
2DNR	OFF/Auto(Level:0~2)/Manual(Gain:0~255/THLD:0~255)			
Defog	Off/On(Low/Middle/High)			
Gamma	0.45/0.50/0.55/0.60			
Lens Shading	On / Off			
Defect Detection	Support			
Digital Image Stabilizer	On / Off			
Picture Effect	OFF /NEGATIVE/ BW (Monochrome Image)			
Trigger Input		Off/Normal		
Strobe Output	Not Support	Off/Free run		
Position Preset (zoom/focus)	Non-volatile 192 position(zoom/focus) presets.			
Memory Preset	16-presets & custom preset			
OSD	English / Russian / Spanish / German /French/ Portuguese / Chinese/ Japanese			
Coaxial Communication	TVI-UTC / AVI-UTC			
Communication (UART)				
Camera ID	0~255			
Remote Control	RS-232 TTL +5.0V (+3.3V Compatible)			
Control Protocol	VISCA, PELCO-D/P/C : Auto Detection	VISCA, PELCO-D/P : Auto Detection		
Communication Speed	2400/4800/9600(default)/19200/38400/57600/115200bps selectable			
Power				
Supply Voltage	DC 12V (+9.0V ~ +15V)			
Supplied Current (motor on)	260mA(570mA)	260mA(570mA)		
Consumption (motor on)	3.1W(6.8W)	3.1W(6.8W)		
Physical				
WxHxD[mm], Weight[g]				
- Standard	53.2x62x101.2mm, Approx. 315g			
Temperature& Humidity				
Operating condition	Temperature (-10°C~50 °C / 14°F~122°F), Humidity (Less than 90%)			
Storage condition	Temperature (-20°C~60 °C / -4°F~140°F), Humidity (Less than 90%)			

INTERFACE SUMMARY

Interface & Video		ATC-HZ8940T-LTA	ATC-HZ8940T-LP
Video Output	EX-SDI (V1.0 / V2.0 / V2.1 /V3.0(TBD))	○	
	HD-SDI	○	
	HD-TVI	○	
	HD-AVI	○	
	PARALLEL		◎
	CVBS	○	○
	LVDS	◎	◎
Interface	30pin Micro Coaxial (USL00-30L-A, 0.4mm)	◎	◎
	36pinFFC (FH12-36S-0.5SH, 0.55mm)		◎
	5pin Trigger&Strobe (SM05B-SRSS-TB,1.0mm)		○
	MMCX	○	
	9pinFFC (52207-0933, 1.0mm)	○	
	4pin AVI / TVI (53261-0471, 1.25mm)	○	
	4pin CVBS&ADKey&12V (53261-0471, 1.25mm)		○
	3pin External D&N (SM03B-SRSS-TB,1.0mm)	○	○
	3pin RS-232TTL (SM03B-SRSS-TB,1.0mm)		○

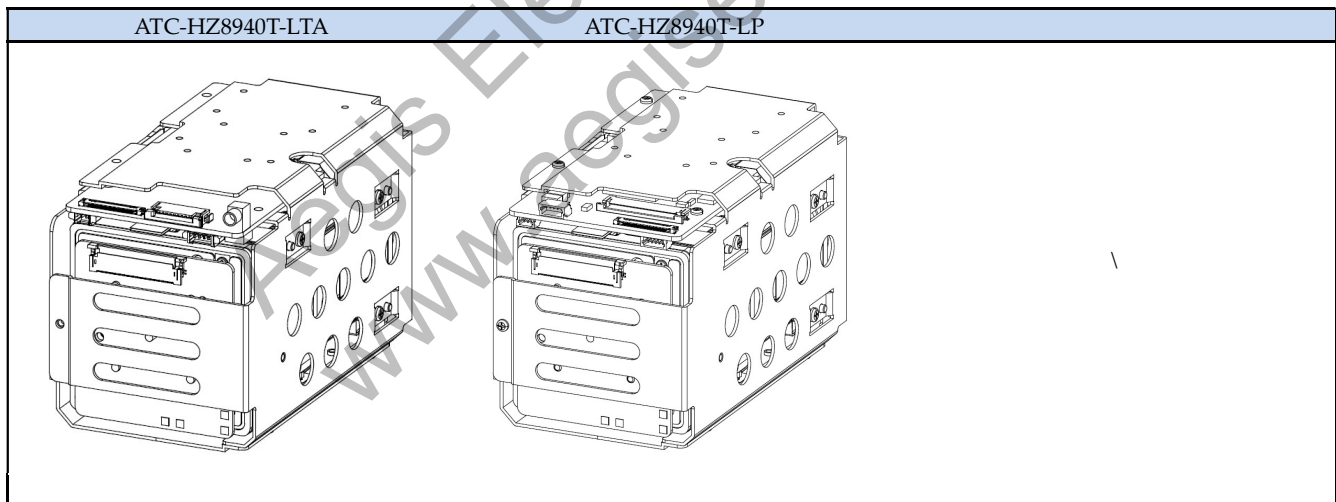

DIMENSION

DIMENSIONS ATC-HZ8940T-LTA

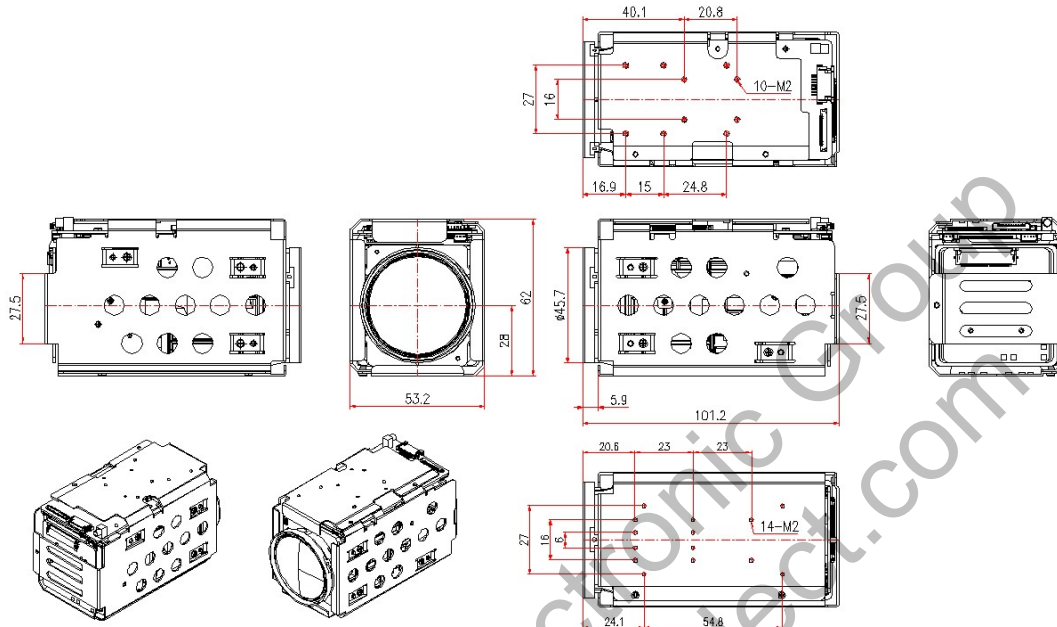

DIMENSIONS ATC-HZ8940T-LP

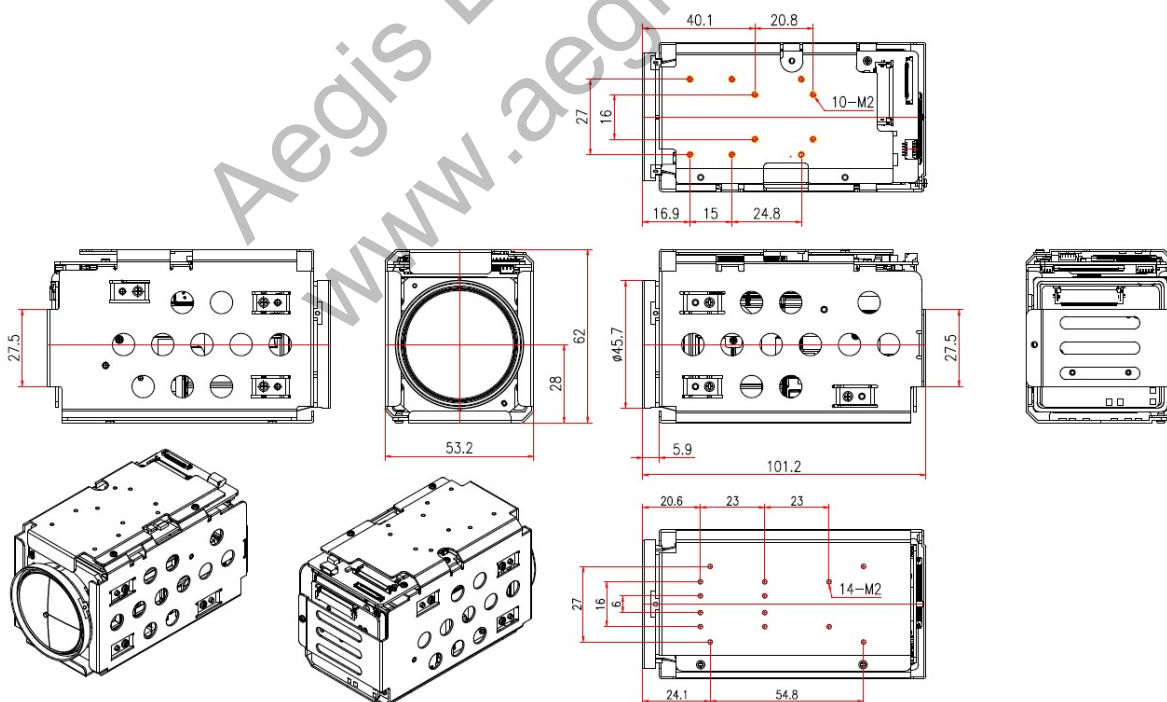

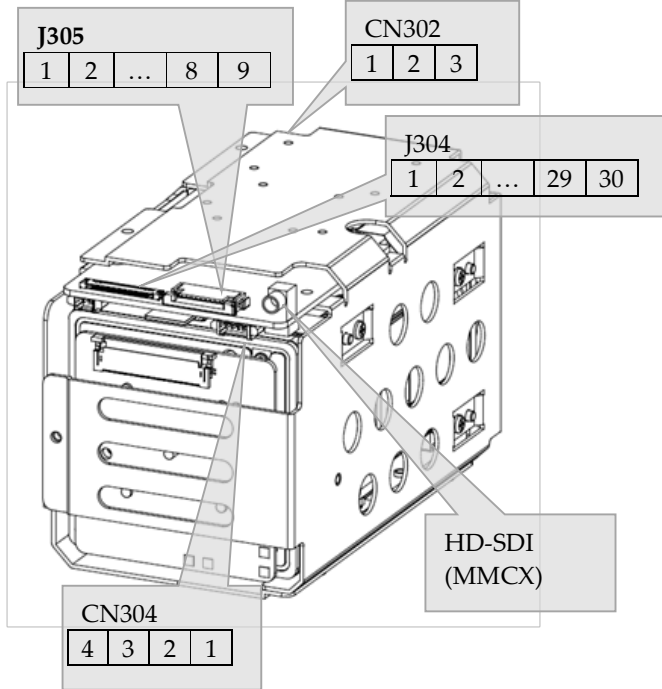

CN304 (TVI/AVI) / Molex : 53261-0471

NO	Name	Description
1	+12V_IN	DV 12V Input
2	GND	GND (DC12V)
3	TVI/AVI OUTPUT	TVI / AVI Output(Select On OSD)
4	GND	GND (TVI / AVI)

J304 (LVDS) / KEL : USL00-30L-C

NO	Name	Description
1	TX_OUT3+	
2	TX_OUT3-	
3	TX_CLKOUT+	LVDS_CLK
4	TX_CLKOUT-	LVDS_CLK
5	TX_OUT2+	
6	TX_OUT2-	
7	TX_OUT1+	
8	TX_OUT1-	
9	TX_OUT0+	
10	TX_OUT0-	
11	GND	
12	TXD	5.0V (compatible 3.3V)
13	RXD	5.0V (compatible 3.3V)
14	+12V DC	
15	+12V DC	
16	+12V DC	
17	+12V DC	
18	+12V DC	
19	GND	
20	GND	
21	TX_OUT7+	Single out mode : open
22	TX_OUT7-	Single out mode : open
23	TX_OUT6+	Single out mode : open
24	TX_OUT6-	Single out mode : open
25	CVBS	CVBS Out
26	RESET_IN	Reset:Low(GND),Normal(1.8V)
27	TX_OUT5+	Single out mode : open
28	TX_OUT5-	Single out mode : open
29	TX_OUT4+	Single out mode : open
30	TX_OUT4-	Single out mode : open

J305 / Molex : 52207-0933 / 52207-0985

NO	Name	Description
1	GND	Optional:AD KEY
2	TVI/AVI OUTPUT	TVI / AVI Output(Select On OSD)
3	GND	
4	CVBS_OUT	CVBS Output
5	GND	
6	+12V_IN	DC 12V Input
7	GND	
8	TXD	5.0V (compatible 3.3V)
9	RXD	5.0V (compatible 3.3V)

CN302 (External D&N) / JST : SM03B-SRSS-TB

NO	Name	Description
1	EXT_D&N	External D&N Input
2	GND	
3	+3.3V	+3.3V Out(For Sensor)

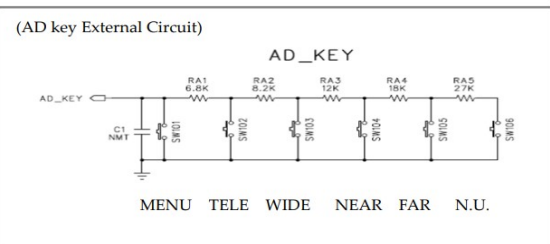

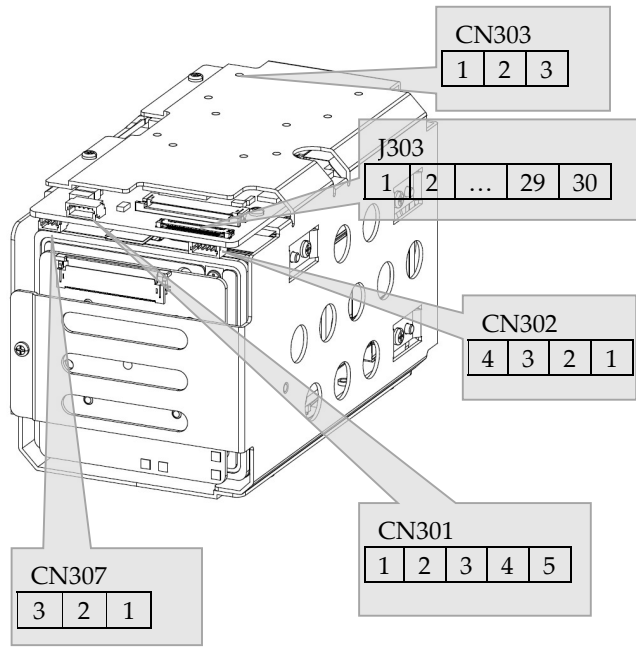

CN301 (Trigger&Strobe) / JST : SM05B-SRSS-TB

NO	Name	Description
1	TRIG_COM	
2	Trigger_IN	EXT_TRIG In
3	STROBE_COM	
4	STROBE_OUT	STROBE
5	GND	

CN302 (CVBS) / Molex : 53261-0471

NO	Name	Description
1	+12V_IN	+12V In
2	GND	
3	CVBS_OUT	CVBS Out
4	AD_KEY	AD_KEY

CN303 (External D&N) / JST : SM03B-SRSS-TB

NO	Name	Description
1	EXT_DN	External D&N Input
2	GND	
3	+3.3V	+3.3V Out (For Sensor)

CN307 (RS232) / JST : SM03B-SRSS-TB

NO	Name	Description
1	GND	
2	RXD(*1)	5.0V (compatible 3.3V)
3	TXD(*1)	5.0V (compatible 3.3V)

J303 (LVDS) / KEL : USL00-30L-C

NO	Name	Description
1	TX_OUT3+	
2	TX_OUT3-	
3	TX_CLKOUT+	LVDS_CLK
4	TX_CLKOUT-	LVDS_CLK
5	TX_OUT2+	
6	TX_OUT2-	
7	TX_OUT1+	
8	TX_OUT1-	
9	TX_OUT0+	
10	TX_OUT0-	
11	GND	
12	TXD	5.0V (compatible 3.3V)
13	RXD	5.0V (compatible 3.3V)
14	+12V DC	
15	+12V DC	
16	+12V DC	
17	+12V DC	
18	+12V DC	
19	GND	
20	GND	
21	TX_OUT7+	Single out mode : open
22	TX_OUT7-	Single out mode : open
23	TX_OUT6+	Single out mode : open
24	TX_OUT6-	Single out mode : open
25	CVBS	CVBS Out
26	RESET_IN	Reset:Low(GND),Normal(1.8V)
27	TX_OUT5+	Single out mode : open
28	TX_OUT5-	Single out mode : open
29	TX_OUT4+	Single out mode : open
30	TX_OUT4-	Single out mode : open

(*1)It cannot be used simultaneously with RXD and TXD signal of J303 or J304.

ATC-HZ8940T-LP continued

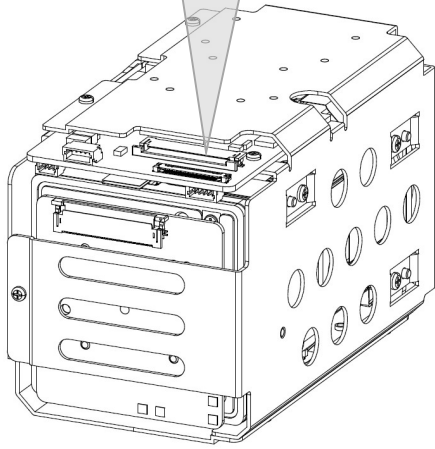
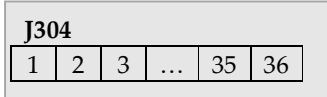

J304 (PARALLEL) / Hirose : FH12-36S-0.5SH

NO	Name	Description
1	GND	
2	Y_OUT[0]	
3	Y_OUT[1]	
4	Y_OUT[2]	
5	Y_OUT[3]	
6	GND	
7	Y_OUT[4]	
8	Y_OUT[5]	
9	Y_OUT[6]	
10	Y_OUT[7]	
11	GND	
12	C_OUT[0]	
13	C_OUT[1]	
14	C_OUT[2]	
15	C_OUT[3]	
16	GND	
17	C_OUT[4]	
18	C_OUT[5]	
19	C_OUT[6]	
20	C_OUT[7]	
21	GND	
22	VSYNC	VSYNC Out
23	HSYNC	HSYNC Out
24	GND	
25	DIGITAL_CLK	VCLK Out
26	GND	
27	GND	
28	GND	
29	GND	
30	GND	
31	+12V_IN	
32	+12V_IN	
33	+12V_IN	
34	GND	
35	TXD	5.0V (compatible 3.3V)
36	RXD	5.0V (compatible 3.3V)

Aegis Electronic Group
www.aegiselect.com

LVDS interface (LVDS model only)

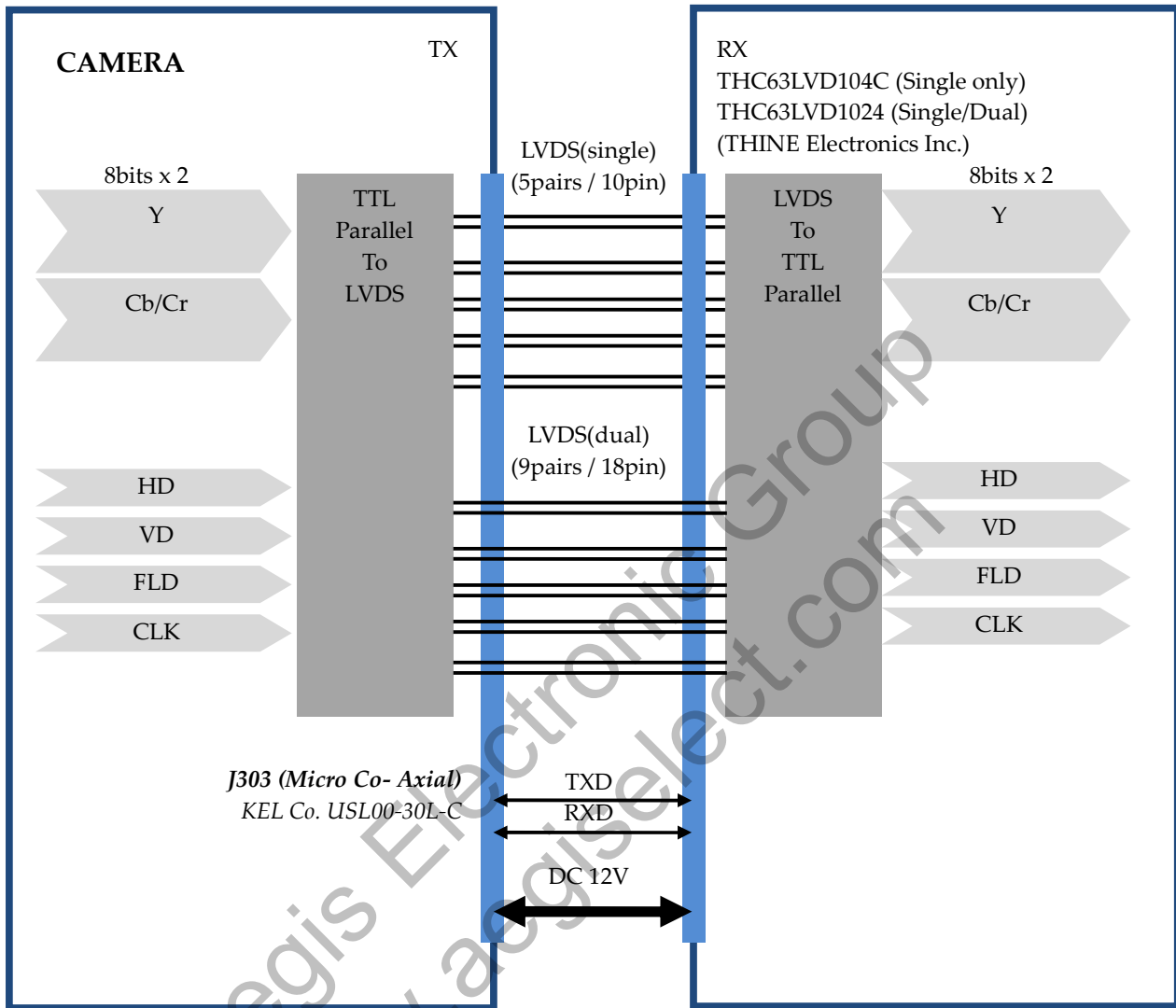

HD Digital Video Sync Signal
74.125MHz

Recommended LVDS receiver IC
(1) Single Only : THC63LVD104C
(2) Single or Dual : THC63LVD1024

Select LVDS output mode

- (1) MENU
SPECIAL -> SYSTEM -> LVDS MODE : SINGLE/DUAL
- (2) VISCA protocol
8x 01 04 24 74 0p 0q FF : pq=00 (single) / pq=01 (dual)

*(caution) If the frame rate is 25 fps / 30 fps, it works as SINGLE even if LVDS MODE is set to DUAL.
However, if the frame rate is 50 fps / 60 fps, LVDS MODE must be set to DUAL to operate as DUAL.*

Single Mode : THC63LVD827 (THINE Electronics Inc.)

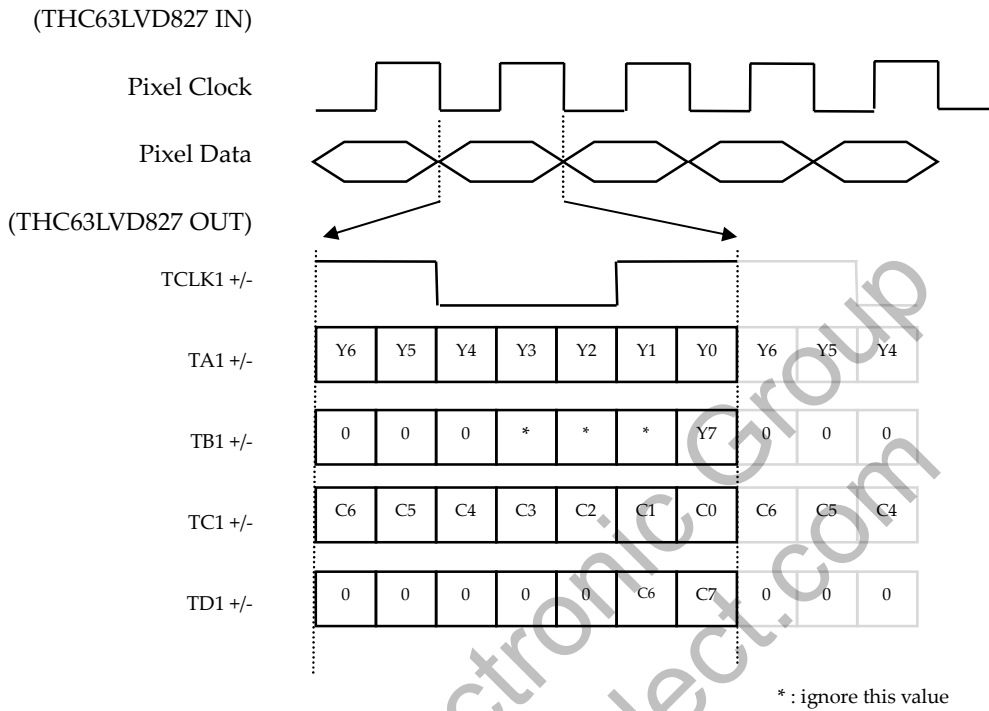

Output Format	Pixel Clock [MHz]	TCLK+ [MHz]
1080p60	148.5	148.5
1080p50	148.5	148.5
1080i60	74.25	74.25
1080i50	74.25	74.25
1080p30	74.25	74.25
1080p25	74.25	74.25
720p60	74.25	74.25
720p50	74.25	74.25
720p30	74.25	74.25
720p25	74.25	74.25

Dual Mode : THC63LVD827 (THINE Electronics Inc.)

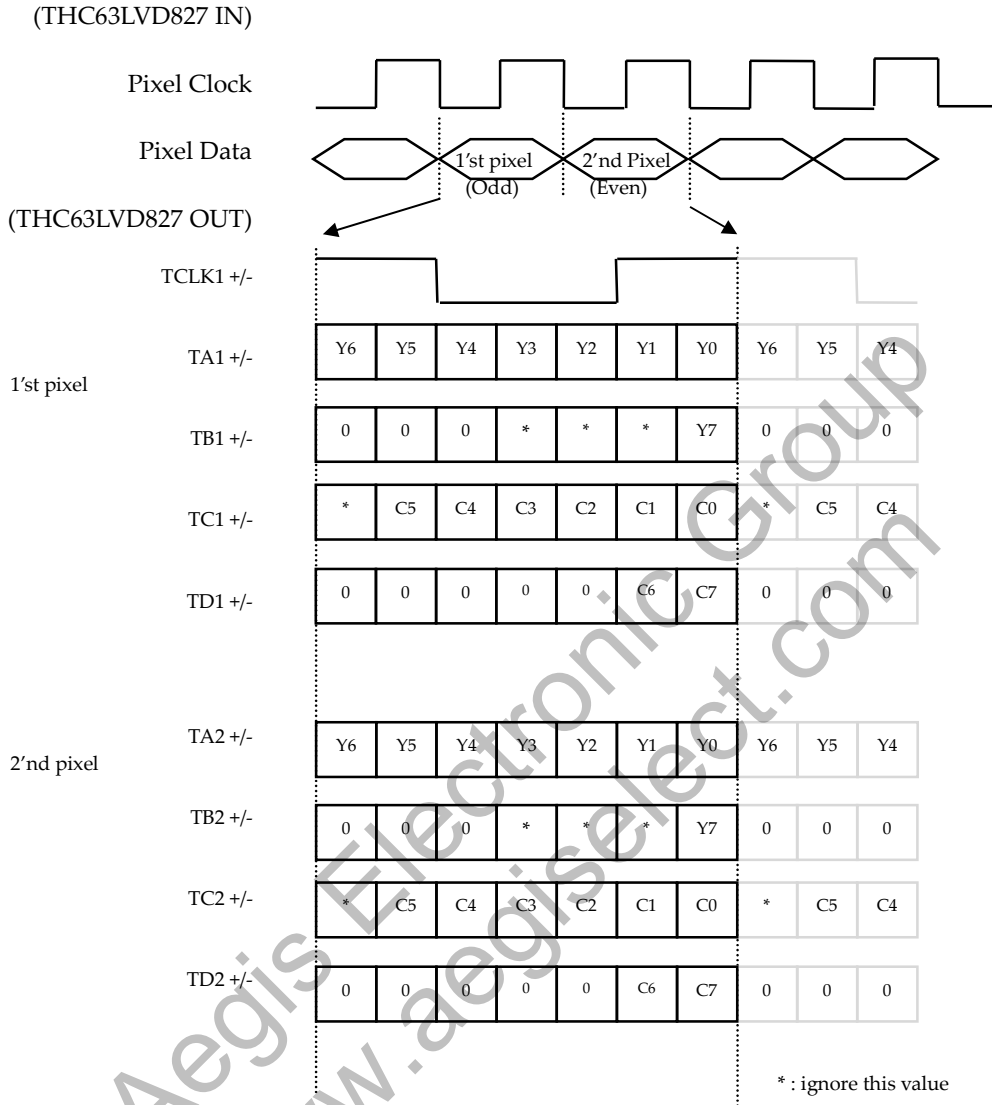

Output Format	Pixel Clock [MHz]	TCLK+ [MHz]
1080p60	148.5	74.25
1080p50	148.5	74.25
1080i60	74.25	37.125
1080i50	74.25	37.125
1080p30	74.25	37.125
1080p25	74.25	37.125
720p60	74.25	37.125
720p50	74.25	37.125
720p30	74.25	37.125
720p25	74.25	37.125

LVDS Single Output receiver circuit example / Receiver IC Pin Assign : THC63LVD104C

Pin No.	Description	Signal
1	GND0	
2	TEST	
3	PD	
4	OE	
5	R/F	
6	RE6	
7	RE5	
8	RE4	
9	VCC0	
10	RE3	
11	RE2	
12	RE1	
13	RE0	
14	RD6	
15	RD5	
16	GND1	
17	RD4	
18	RD3	
19	RD2	
20	RD1	
21	RD0	C7
22	RC6	C6
23	VCC1	
24	RC5	C5
25	RC4	C4
26	RC3	C3
27	RC2	C2
28	RC1	C1
29	RC0	C0
30	GND2	
31	CLK_OUT	PCLK
32	RB6	

Pin No.	Description	Signal
33	RB5	
34	RB4	
35	RB3	FLD
36	RB2	VSYNC
37	VCC2	
38	RB1	HSYNC
39	RB0	Y7
40	RA6	Y6
41	RA5	Y5
42	RA4	Y4
43	RA3	Y3
44	GND3	
45	RA2	Y2
46	RA1	Y1
47	RA0	Y0
48	VCC3	
49	RA-	TXOUT0-
50	RA+	TXOUT0+
51	RB-	TXOUT1-
52	RB+	TXOUT1+
53	LVCC	
54	RC-	TXOUT2-
55	RC+	TXOUT2+
56	RCLK-	TXCLKOUT-
57	RCLK+	TXCLKOUT+
58	LGND	
59	RD-	TXOUT3-
60	RD+	TXOUT3+
61	RE-	
62	RE+	
63	PGND	
64	PVCC	

LVDS Single Output receiver circuit example / Receiver IC : THC63LVD1024

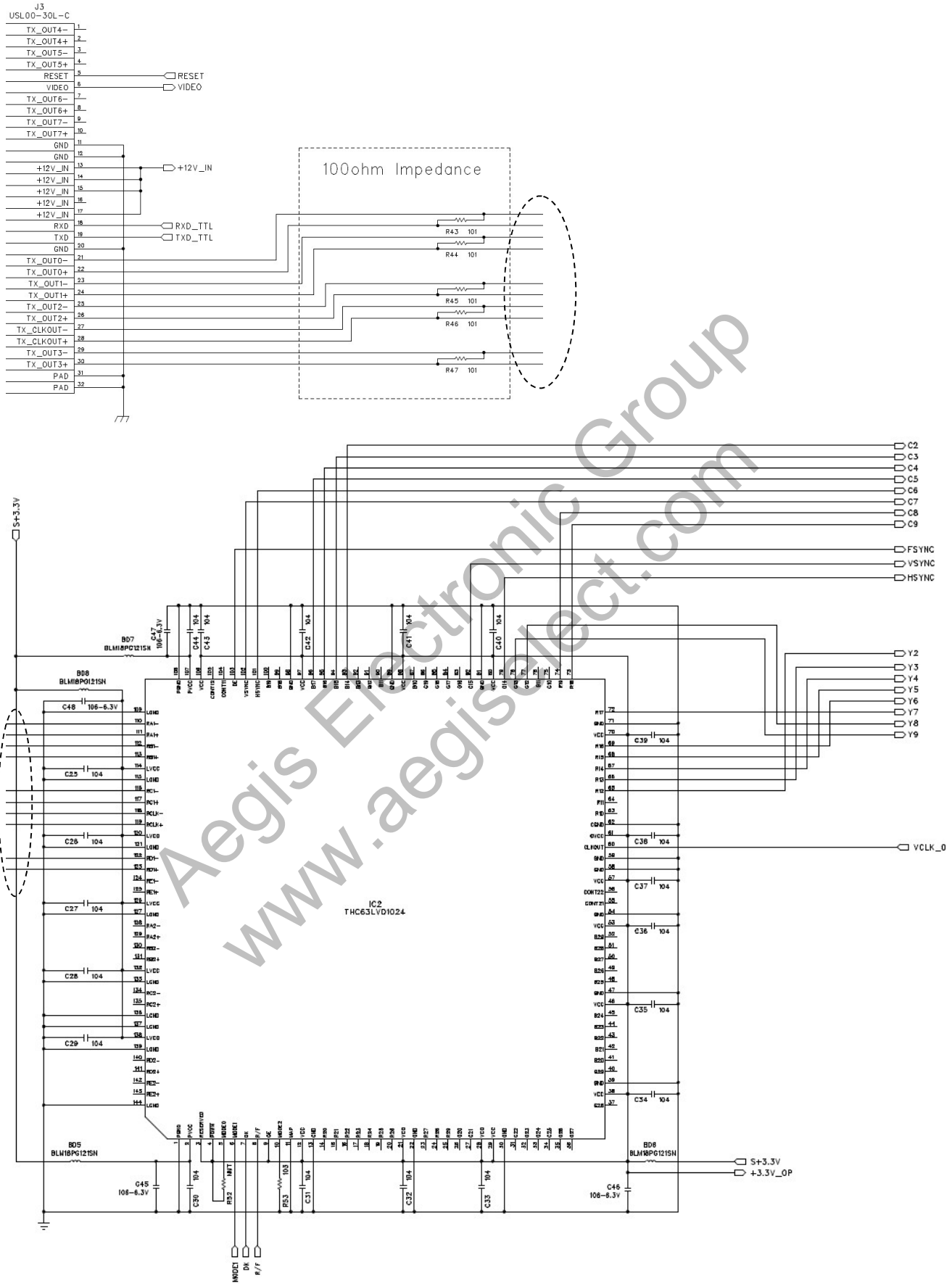

LVDS Single/Dual Output receiver circuit example / Receiver IC Pin Assign : THC63LVD1024

Pin No.	Description	Signal
1	PGND	
2	PVCC	
3	RESERVED	
4	PDWN	
5	MODE0	
6	MODE1	MODE1
7	DK	DK
8	R/F	R/F
9	OE	
10	MODE2	
11	MAP	
12	VCC	
13	GND	
14	R20	
15	R21	
16	R22	
17	R23	
18	R24	
19	R25	
20	R26	
21	VCC	
22	GND	
23	R27	
24	R28	
25	R29	
26	G20	
27	G21	
28	VCC	
29	VCC	
30	GND	
31	G22	
32	G23	
33	G24	
34	G25	
35	G26	
36	G27	
37	G28	
38	VCC	
39	GND	
40	G29	
41	B20	
42	B21	
43	B22	
44	B23	
45	B24	
46	VCC	
47	GND	
48	B25	
49	B26	
50	B27	

Pin No.	Description	Signal
51	B28	
52	B29	
53	VCC	
54	GND	
55	CONT21	
56	CONT22	
57	VCC	
58	GND	
59	GND	
60	CLKOUT	VCLK
61	CVCC	
62	CGND	
63	R10	
64	R11	
65	R12	Y2
66	R13	Y3
67	R14	Y4
68	R15	Y5
69	R16	Y6
70	VCC	
71	GND	
72	R17	Y7
73	R18	C9
74	R19	C8
75	G10	
76	G11	
77	G12	Y8
78	G13	Y9
79	G14	HSYNC
80	VCC	
81	GND	
82	G15	VSYNC
83	G16	
84	G17	
85	G18	
86	G19	
87	B10	
88	VCC	
89	GND	
90	B11	
91	B12	
92	B13	
93	B14	C2
94	B15	C3
95	B16	C4
96	B17	C5
97	VCC	
98	GND	
99	B18	
100	B19	

Pin No.	Description	Signal
101	HSYNC	C6
102	VSYNC	C7
103	DE	FSYNC
104	CONT11	
105	CONT12	
106	VCC	
107	PVCC	
108	PGND	
109	LGND	
110	RA1-	TXOUT0-
111	RA1+	TXOUT0+
112	RB1-	TXOUT1-
113	RB1+	TXOUT1+
114	LVCC	
115	LGND	
116	RC1-	TXOUT2-
117	RC1+	TXOUT2+
118	RCLK-	TXCLKOUT-
119	RCLK+	TXCLKOUT+
120	LVCC	
121	LGND	
122	RD1-	TXOUT3-
123	RD1+	TXOUT3+
124	RE1-	
125	RE1+	
126	LVCC	
127	LGND	
128	RA2-	TXOUT4-
129	RA2+	TXOUT4+
130	RB2-	TXOUT5-
131	RB2+	TXOUT5+
132	LVCC	
133	LGND	
134	RC2-	TXOUT6-
135	RC2+	TXOUT6+
136	LGND	
137	LGND	
138	LVCC	
139	LGND	
140	RD2-	TXOUT7-
141	RD2+	TXOUT7+
142	RE2-	
143	RE2+	
144	LGND	

OSD & MENU

1'ST ITEM	2'ND ITEM	3'RD ITEM or DATA	4'TH ITEM or DATA	5'TH ITEM or DATA
FOCUS	AF MODE	AUTO / INTERVAL / ONE SHOT / MANUAL / PRESET		
	DZOOM	OFF/ON		
	ZOOM START	1~40		
	ZOOM STOP	1~480		
	ZOOM SPEED	0~7		
	FOCUS LIMIT	1CM/10CM/50CM/1M/1.2M/1.3M/1.5M/2M/3M/5M/10M/50M/100M/500M/INF		
	AF INTERVAL	1~255		
	HOME POSITION	OFF / ON		
	IR CORRECT	STANDARD/IR LIGHT/USER -20~-20		
	PRESET POSITION	Select Target		
	PRESET MARGIN	4~255		
	CONT. AF MODE	OFF / ON		
	CONT. AF SPEED	0~16		
	INITIAL	OK		
	RETURN			
EXPOSURE	AE MODE	AUTO / IRIS.PRI / SHUT.PRI / MANUAL		
	FLICKERLESS	OFF / ON		
	IRIS	CLOSE / F19 / F16 / F14 / F11 / F9.6 / F8 / F6.8 / F6 / F5.4 / F4.8 / F4.2 / F3.8 / F3.4 / F2.8 / F2.4 / F2.0 / F1.6		
	SHUTTER	1/1~1/30000		
	AGC	OFF / 4dB / 8dB / 12dB / 16dB / 20dB / 24dB / 28dB / 32dB / 36dB / 40dB / 44dB / 48dB		
	AGC MAX	OFF / 4dB / 8dB / 12dB / 16dB / 20dB / 24dB / 28dB / 32dB / 36dB / 40dB / 44dB / 48dB		
	SENS-UP	OFF/X2/X4/X8/X16/X32		
	BRIGHTNESS	1~20		
	INITIAL	OK		
	RETURN			
WHITE BALANCE	WB MODE	AUTO / INDOOR / OUTDOOR / ONE PUSH / ATW / MANUAL		
	PUSH AUTO	PRESS OK/WAIT		
	COLOR GAIN	0~20		
	RED GAIN	0~255		
	BLUE GAIN	0~255		
	INITIAL	OK		
	RETURN			
WDR/BLC	MOFE	OFF / BLC / HLC / WDR		
	LEVEL(HLC)	0~20		
	LEVEL(BLC)	0~10		
	LEVEL(WDR)	LOW / MIDDLE / HIGH		
	BLC X-POSITION	0~20		
	BLC Y-POSITION	0~20		
	BLC X-SIZE	0~20		
	BLC Y-SIZE	0~20		
	COLOR	BLACK / WHITE / YELLOW / CYAN / GREEN / MAGENTA / RED / BLUE		
	ININTIAL	OK		
	RETURN			
DAY&NIGHT	MODE	AUTO/ COLOR(DAY)/ B&W(NIGHT)/EXT-H/EXT-L		
	DWELL TIME	0~255 SEC		
	D->N LEVEL	1~28		
	N->D LEVEL	0~27		
	IR SMART	0~20		
	INITIAL	OK		
	RETEUN			
IMAGE	SHARPNESS	0~15		

IMAGE	GAMMA	0.45/0.5/0.55/0.60				
	MIRROR	OFF / H-FLIP / V-FLIP / HV-FLIP				
	FREEZE	OFF/ON				
	D-WDR	OFF / LOW / MIDDLE / HIGH				
	DEFOG	MODE	OFF / ON			
		AUTO LEVEL	LOW / MIDDLE / HIGH			
		RETURN				
	SHADING	MODE	OFF / ON			
		SHADING LEVEL	0-100			
		RETURN				
	DNR	3DNR MODE	OFF / AUTO / MANUAL			
		3DNR LEVEL	0-2			
		3DNR GAIN	0-255			
		3DNR THLD	0-255			
		3DNR FK	0-255			
		2DNR MODE	OFF / AUTO / MANUAL			
		2DNR LEVEL	0-2			
		2DNR GAIN	0-255			
		2DNR THLD	0-255			
		RETURN				
DIS	MODE	OFF / ON				
	RANGE	10% / 20% / 30%				
	FILTER	LOW / MIDDLE / HIGH				
	AUTO C	OFF / HALF / FULL				
	RETURN					
EFFECT	PIC.EFFECT	OFF / NEGATIVE / BW				
	HR MODE	OFF / ON				
	RETURN					
INITIAL	OK					
RETURN						
SPECIAL	CAM TITLE	EDIT PANEL				
		<pre> ↓ ----- A B C D E F G H I J K L M N O P Q R S T U V W X Y Z ! ? () [] 0 1 2 3 4 5 6 7 8 9 ? * : " / . SPA>> <<BAK </pre>				
		DISPLAY	OFF/ON			
		LOCATION	[POSITION EDIT]			
		RETURN				
		DISPLAY	CAM ID DISP	OFF / ON		
			CAM ID POSI	[POSITION EDIT]		
			ZOOM MAG DISP	OFF / ON		
			ZOOM MAG POSI	[POSITION EDIT]		
			INITIAL	OK		
	RETURN					
	PRIVACY	MODE	OFF/ON			
		MASK NO	1-8			
		DISPLAY	OFF/ON			
		P/T LOCK	OFF/ON			
		POSITION	[POSITION EDIT]			
		SIZE	[SIZE EDIT]			
		COLOR	BLACK / GRAY1 / GRAY2 / GRAY3 / GRAY4 / GRAY5 / GRAY6 / WHITE / RED / GREEN / BLUE / CYAM / YELLOW / MAGENTA			
		TRANSPARENCY	OFF / 25% / 50% / 75%			
		ZONE RESET	OFF / OK			
	INITIAL	OK				

SPECIAL	PRIVACY	RETURN		
	MOTION	MODE	OFF/ON	
		ZONE NO	1~4	
		ZONE DETECT	OFF / ON	
		X-POSITION	0~60	
		Y-POSITION	0~34	
		X-SIZE	0~60	
		Y-SIZE	0~34	
		SENSITIVITY	0~10	
		ALARM MODE	OFF / WINDOW / TEXT / WINDOW&TEXT	
		INITIAL	OK	
		RETURN		
	INITIAL	OK		
RETURN				
SYSTEM (*It is not initialized by "Factory default")	FRAMERATE	1080_30P / 1080_25P / 720_30P / 720_25P / 720_60P / 720_50P / 1080_60P / 1080_50P / 1080_60I / 1080_50I		
	SDI	OFF/HDSDI/EXSDI-135M-EXSDI-270M		
	VIDEO TYPE	TVI/AVI		
	APPLY			
	LANGUAGE	ENGLISH / Русский / Español / DEUTSCH / FEANCAISE / Português / 中国 / 日本語		
	CVBS	16:9 / 4:3		
	LVDS MODE	SINGLE / DUAL		
	COLOR	BYGAIN-	0~255	
		BYGAIN+	0~255	
		RYGAIN-	0~255	
		RYGAIN+	0~255	
		BYHUE-	0~255	
		BYHUE+	0~255	
		RYHUE-	0~255	
		RYHUE+	0~255	
		REDGAIN	0~255	
		GREENGAIN	0~255	
		BLUE GAIN	0~255	
		RESET		
		RETURN		
	COM	CAM ID	0~255	
		BAUDRATE	2400/4800/9600/19200/38400/57600/115200	
		APPLY		
		RETURN		
	TRIGGER&STROBE *Support : LP Model	TRIGGER MODE	OFF/NORMAL	
		FREERUN MODE	OFF/ON	
		STROBE WIDTH	1~255	
POLARITY		ACTIVE HIGH/ACTIVE LOW		
RETURN				
RETURN				
FACTORY RESET	OK			
EXIT				

FUNCTIONS

Auto Focus Near Limit

You can set the minimum focus distance from 1cm(or 10cm) to infinite. It is available only at high magnification zoom position.

This is called by FOCUS LIMIT or NEAR LIMIT or M.O.D (Minimum object distance). This is mostly used to avoid focusing on objects of close range.

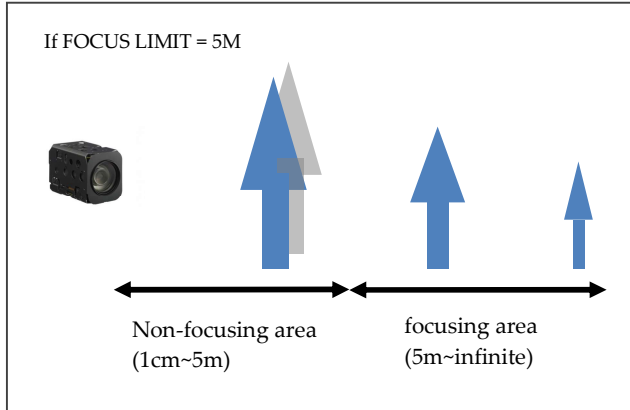

Auto Focus Mode

• AUTO

When a change in the image is detected, the AF operation is automatically performed.

• INTERVAL

It is used for AF movements carried out at particular intervals.

• ONESHOT

When the zoom is changed, auto focus is executed only once. The AF range is from FOCUS LIMIT to infinity. It is called by "ONE PUSH" or "ZOOM TRIGGER" mode.

• MANUAL

Adjust zoom and focus manually.

• PRESET (*3)

Always focus on the specified subject. When the zoom is changed, auto focus is executed only once. The AF range (=PRESET MARGIN) is limited to a specific range.

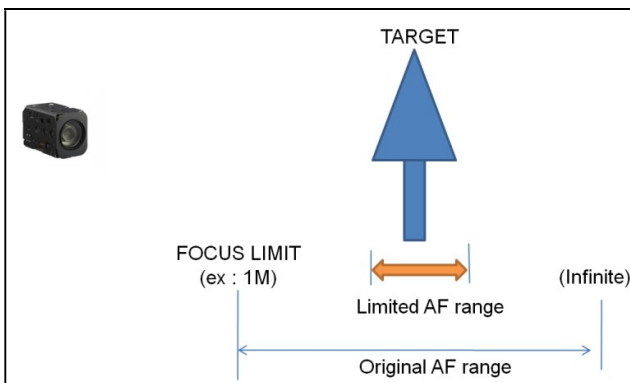

• The PRESET AF mode is useful when you need to focus only on objects of a specific distance that require little PAN / TILT operation after installing the camera.

• The PRESET MARGIN is the AF operating range at the maximum zoom scale. This range is automatically adjusted according to the zoom magnification

< PRESET setting method - 1 >

- (1) Enter MENU
- (2) Change AF mode to PRESET
- (3) Enter PRESET POSITION menu
- (4) Move to maximum zoom scale (OK is displayed on the screen)
- (5) Adjust focus
- (6) Exit PRESET POSITION menu
- (7) Adjust PRESET MARGIN data (4-255)

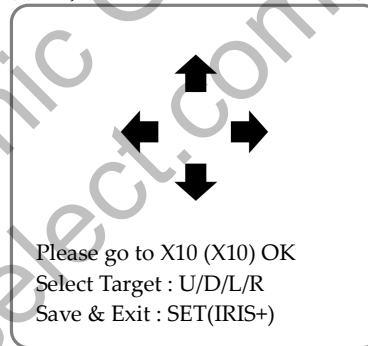

< PRESET setting method - 2 >

KT_PresetAF (Active Only Preset Mode)	Disp. Setting OSD	8x 01 70 02 00 FF
	Cancel & Exit	8x 01 70 02 01 FF
	Save & Exit	8x 01 70 02 02 FF
	Test PRESET	8x 01 70 02 10 FF
	Set Preset AF Range	8x 01 70 03 0p 0q FF

(1) If you want to output the PRESET POSITION setting screen, send SETTING OSD command.

(2) To save the current zoom and focus position in the PRESET position, send the SAVE & EXIT command. To end without saving, send CANCEL&EXIT command.

(3) To save the current zoom and focus position to PRESET position without outputting PRESET POSITION menu, send SAVE & EXIT command.

Automatic Exposure Mode

- **Full Auto mode**
Iris, Gain, Shutter speed can be set automatically.
- **Iris Priority mode**
Variable Iris : Close ~ F1.6, 18steps
Auto Gain & Shutter
- **Shutter Priority mode**
Variable shutter speed : 1/1(X32)~1/30000
Auto Iris & Gain
- **Manual mode**
Variable Iris/Shutter/Gain
- **AE Mode : AUTO/IRIS.PRI/SHUT.PRI/MANUAL**

MODE	AUTO	IRIS.PRI	SHUT.PRI	MANUAL
FLICKERLESS	O	X	X	X
IRIS	X	O	X	O
SHUTTER	X	X	O	O
AGC	X	X	X	O
AGC MAX	O	O	O	X
SENS UP	O	O	X	X
BRIGHTNESS	O	O	O	X

Exposure Compensation

It is a function which offsets the internal reference brightness level used in the AE mode.

CAM_ExpComp (Active Only ExpComp Mode)	8x 01 04 4E 00 00 0p 0q FF	pq=compensation level
--	-------------------------------	-----------------------

(NOTE) See "Command Setting Values"

Wide Dynamic Range (WDR)

Images with WDR are produced by combining long-exposure signals(normal shutter) with the signal of the high-intensity portions obtained a short-exposure (high-speed shutter).

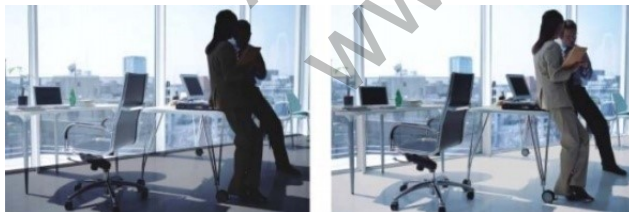

WDR OFF

WDR ON

High-Light Compensation (HLC)

It's ability to reverse bright points in the picture to black. As an effective approach to recognize vehicle plate number at night, HLC function can detect any spotlight diffused by object-vehicle and compensate it for obtaining clearer image.



Spot AE

- Available in Full Auto AE mode.
- A particular section of the subject can be designated, and then that portion of the image can be weighted and a value computed so that iris and gain can be optimized to obtain an image.

0	1	2	3	4	5	6	7	8	9	A	B	C	D	E	F
1															
2															
3															
4															
5															
6															
7															
8															
9															
A															
B															
C															
D															
E															
F															

CAM_SpotAE	On	8x 01 04 59 02 FF	Spot AE mode
	Off	8x 01 04 59 03 FF	
	Position	8x 01 04 29 00 0p 00 0q FF	p:X(0-F), q:Y(0-F)

Noise Reduction

- 3D-NR
- 2D-NR

Defog

- Sharpens cloudy images such as fog.

Slow AE Response

The Slow AE Response function allows you to reduce the exposure response speed.
(example) If the headlights of a car are caught by the camera, the camera automatically adjusts the exposure so that it can shoot a high-intensity subject. Since AE responds slowly, it can be prevented images from being shot.

CAM_AE_Response	8x 01 04 5D pp FF	pp: 00 to 254 default 64
-----------------	-------------------	-----------------------------

Digital Image Stabilizer

This function reduces image blurring caused by vibration

• **RANGE** : Set the compensation range. Up to 30% of the input image range is used, and digital zoom is required up to 1.4 times according to the setting.

• **FILTER** : Correction filter for the worst case of the image (built-in Hold filter). If you increase the setting value, the correction becomes less. If you decrease the setting value, the correction becomes better. However, a malfunction may occur in a moving subject or a low-illuminance / no-pattern image.

• **AUTO C** : Auto Centering to distinguish camera shake from PANNING. It compensates for high frequency vibrations such as tremor and allows the screen to move naturally to the camera's PANNING. In the case of FULL, the camera always corrects the direction in which the image is positioned at the center of the image. In the case of HALF, the center of the correction area is completely corrected (PANNING is ignored) and only the periphery is centered.



(before)

(after)

Home Position Mode

After power on, you can choose whether to move to the last position before power off or to x1 position.

KT_HomePowerOn	On	8x 01 70 24 02 FF	Moving to x1 position
	Off	8x 01 70 24 03 FF	Move to final position before power off

Memory Preset

16 sets of camera shooting conditions can be stored and recalled.

- Zoom Position
- Digital Zoom Mode
- Focus Mode
- AE mode
- Shutter control parameters
- Bright , Iris, Gain
- Exposure Compensation mode
- Exposure Level
- Backlight Compensation mode
- Auto Slow Shutter On/Off
- White Balance mode
- Red/Blue Gain
- Aperture Control
- ICR mode, Defog, WDR mode

CAM_Memory	Reset	8x 01 04 3F 00 0p FF	p:Memory Number(0~F)
	Set	8x 01 04 3F 01 0p FF	
	Recall	8x 01 04 3F 02 0p FF	

(See. Custom/Memory Preset Setting Items)

Custom Preset

As with the memory preset function, the camera shooting conditions can be saved and recalled. The settings are recalled when the power is turned on.

- The above memory preset contents
- Privacy mask, Motion detect , Title
- Flip, mirror, negative, BW, Gamma, DNR, DIS, AF controls, camera ID, HLC, ETC.

CAM_Custom	Reset	8x 01 04 3F 00 7F FF	Starts up in this mode when the power is turned on
	Set	8x 01 04 3F 01 7F FF	
	Recall	8x 01 04 3F 02 7F FF	
	Inactive	8x 01 04 3F 10 7F FF	
	Active	8x 01 04 3F 11 7F FF	

(See. Custom/Memory Preset Setting Items)

(NOTE)

You can decide whether to use a custom preset.

When the product is shipped, custom preset is disabled(inactive mode)

To enable the custom preset, the user must send **SET/RECALL** or **ACTIVE** command.

To disable the custom preset, send **INACTIVE** command.

<Custom Preset Mode>

When the power is turned on,

- **Active** : starts up in the custom preset settings

- **Inactive** : starts up in the settings before the power is turned off

(factory shipment default : Inactive mode)

User Memory Area

You can use up to 16 bytes to store data such as camera number.

Position Preset

The current zoom / focus position can be stored in the internal memory and moved to that position if necessary. A total of 192 locations can be stored.

KT_ZoomFocus Preset	Set	8x 01 70 3F 01 0p 0q 0r FF	pqr : preset Number (0x000-0x0BF)
	Recall	8x 01 70 3F 02 0p 0q 0r FF	
	Clear	8x 01 70 3F 03 0p 0q 0r FF	
	Clear All Preset	8x 01 70 3F 0F 00 00 00 FF	Clear all preset data
KT_ZoomFocus PresetInq	8x 09 70 3F 0n 0n 0n FF	y0 50 0v 0z 0z 0z 0z 0f 0f 0f 0f FF	nnn: preset number (0x000-0x0BF) v : 1(saved), 0(empty) zzzz : zoom position ffff : focus position

Day & Night Setting

• AUTO Mode

If the current illumination is darker than the ICR ON level, the IR cut filter is removed. If it is brighter than the ICR OFF level, the IR cut filter is enabled.
ICR ON level = Day To Night level
ICR OFF level = Night To Day level

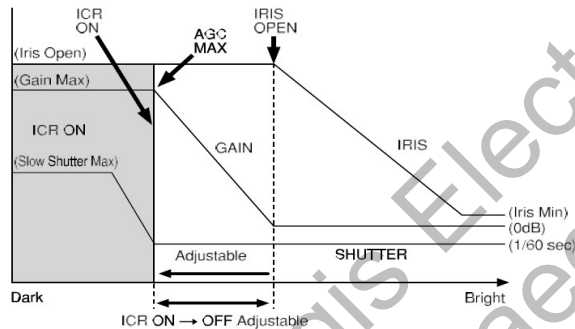

• DAY Mode (=ICR OFF fixed)

It always maintains the DAY (color) state regardless of the current illumination.

• NIGHT Mode (=ICR ON fixed)

It always maintains the NIGHT (B/W) state regardless of the current illumination.

• EXT-L/H Mode

DAY / NIGHT is determined according to the external input signal.

In EXT-H mode, when 3.3v is entered, it switches to Night mode.

In EXT-L mode, when 3.3v is entered, it enters Day mode.

KT_DayNightMod e ⁽³⁾	Auto	8x 01 70 04 00 FF
	Day	8x 01 70 04 01 FF
	Night	8x 01 70 04 02 FF
	Ext-High	8x 01 70 04 03 FF
	Ext-Low	8x 01 70 04 04 FF

Motion Detect Function

Motion Detect functions instructs the camera to detect movement within monitoring area and then send an alarm signal automatically.

◇ Frame

You can set up to 4-frames

Each frame can be set up :

Using VISCA : 16 (horizontally)×8 (vertically) blocks

Using MENU : 60 (horizontally)×34 (vertically) blocks

◇ Sending Alarms

- When motion is detected, the Alarm Replay command is issued via the serial command (VISCA) communication line.

- When multiple motions are detected or motion is detected in another frame within the set interval following the original time the alarm was issued, another alarm command is not issued.

- When motion is detected after the interval time elapsed, the alarm is issued again.

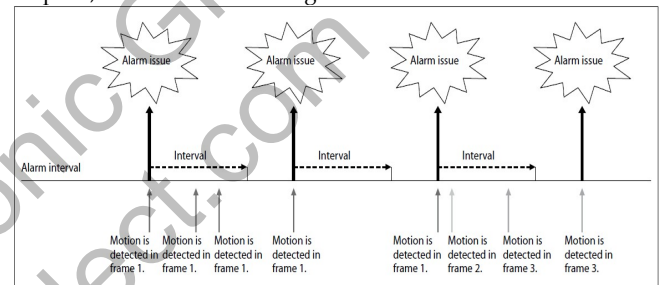

On	8x 01 04 1B 02 FF	Motion Detection On/Off
Off	8x 01 04 1B 03 FF	
Window Set (Display when Zone detect ON)	8x 01 04 1D 0m 0p 0q rr 0s FF	m: Select Detection Frame (0, 1, 2, 3) p: Start Horizontal Position (00 to 0F) q: Start Vertical Position (00 to 07) r: Stop Horizontal Position (01 to 10) s: Stop Vertical Position (01 to 08)
Alarm (Reply) (Active Interval time set)	y0 07 04 1B 0p FF	p: Detection Frame Number

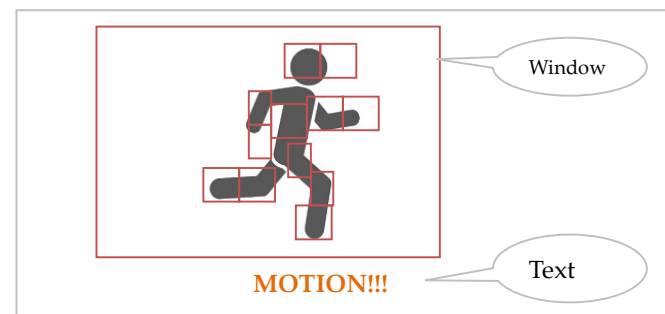

(*) Blocks are output only within the Frame area.

Privacy Zone Masking

Privacy Zone masking protects private objects and areas such as house windows, entrances, and exits which are within the camera's range of vision but not subject to surveillance. Privacy zone masking can be masked on the monitor to protect privacy.

- Mask can be set on up to 16 places according to Pan/Tilt positions.
- Interlocking control with zooming.
- Interlocking control with Pan/Tilt.
- Non-interlocking control with Pan/Tilt.

Command Set	Command	Command	Comments
CAM_PrivacyZone	SetMask	8x 01 04 76 mm nn 0r 0r 0s 0s FF	Setting Mask(Size) See "mm: Mask setting list", "nn: Setting", and "rr: w, ss: h" in "Parameters"
	Display	8x 01 04 77 pp pp pp pp FF	Setting Mask Display On/Off See "pp pp pp pp: Mask bit" in "Parameters". pp pp pp pp: Mask setting (0: OFF, 1: ON)
	SetMaskColor	8x 01 04 78 pp pp pp pp qq rr FF	Setting Color of Mask See "pp pp pp pp: Mask bit" and "qq, rr: Color code" in "Parameters". qq: Color setting when setting the Mask bit to 0 rr: Color setting when setting the Mask
	SetPanTiltAngle	8x 01 04 79 0p 0p 0p 0q 0q 0q FF	Setting Pan/Tilt Angle See "Setting pan/tilt angle" in "Parameters". ppp: Pan angle, qqq: Tilt angle
	SetPTZMask	8x 01 04 7B mm 0p 0p 0p 0q 0q 0r 0r 0r 0r FF	Setting the direct position of PTZ See "mm: Mask setting list" and "Setting pan/tilt angle" in "Parameters". ppp: Pan, qqq: Tilt, rrrr: Zoom
	Non_InterlockMask	8x 01 04 6F mm 0p 0p 0q 0q 0r 0r 0s 0s FF	Setting non-interlocking the mask to pan/tilt See "mm: Mask setting list" and "pp:x,qq:y, rr:w, ss: h" in "Parameters"

Inquiry Command	Command Packet	Inquiry Packet	Comments
CAM_Privacy DisplayInq	8x 09 04 77 FF	y0 50 pp pp pp pp FF	Inquiry about the status of Setting Mask Display On/ Off See "pp pp pp pp: Mask bit" in "Parameters". 1:On, 0:Off
CAM_PrivacyPan TiltInq	8x 09 04 79 FF	y0 50 0p 0p 0p 0q 0q 0q FF	Inquiry about the pan/tilt position currently set See "Setting pan/tilt angle" in "Parameters". ppp: Pan, qqq: Tilt
CAM_PrivacyPTZI nq	8x 09 04 7B mm FF	y0 50 0p 0p 0p 0q 0q 0q 0r 0r 0r 0r FF	Inquiry about pan/tilt/zoom position at the mm Mask setting See "mm: Mask setting list" and "Setting pan/tilt angle" in "Parameters". ppp: Pan osition, qqq: Tilt Position rrrr: Zoom
CAM_Privacy MonitorInq	8x 09 04 6F FF	y0 50 pp pp pp pp FF	Inquiry about the mask currently displayed See "pp pp pp pp: Mask bit" in "Parameters".

- Mask Number : A=0x00, B=0x01,...W=0x16, X=0x17 (total 24 masks)
- Mask Bit & Mask List(mm)

byte	pp pp pp pp (mask bit) or mm(Mask list)																															
	pp								pp								pp								pp							
bit	7	6	5	4	3	2	1	0	7	6	5	4	3	2	1	0	7	6	5	4	3	2	1	0	7	6	5	4	3	2	1	0
Mask	-	-	-	-	-	-	-	-	-	-	-	-	P	O	N	M	-	-	L	K	J	I	H	G	-	-	F	E	D	C	B	A
List(mm)													0F	0E	0D	0C			0B	0A	09	08	07	06			05	04	03	02	01	00

The priority order of the mask display is in the sequence from A (highest) to P (lowest).

● **Pan/Tilt Angle**

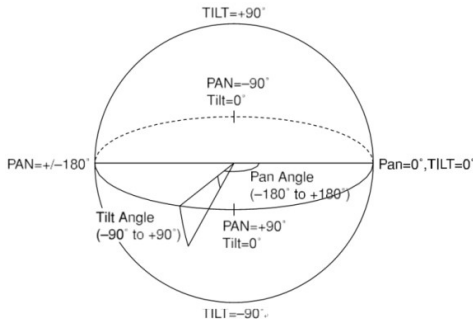
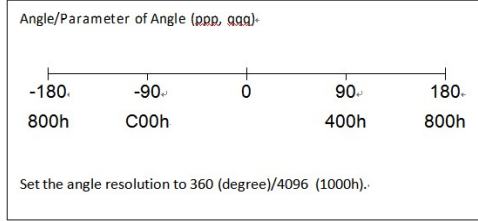

- ✓ You can use the tilt angle at which you can set the mask between -90 to +90 degrees. But the recommended tilt angle is between -70 to +70 degrees.
- ✓ It is recommended that you set the size to at least twice the size of the object (height and width).

● **Mask Color (qq, rr)**

Mask (Color)	Normal	Translucence
Black	00h	10h
Gray1	01h	11h
Gray2	02h	12h
Gray3	03h	13h
Gray4	04h	14h
Gray5	05h	15h
Gray6	06h	16h
White	07h	17h
Red	08h	18h
Green	09h	19h
Blue	0Ah	1Ah
Cyan	0Bh	1Bh
Yellow	0Ch	1Ch
Magenta	0Dh	1Dh

● **Mask Size : Width/Height**

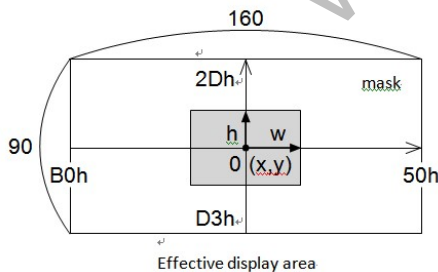

Title / Function Display

The user can output desired characters on the screen and can also choose the output font size.

See. "CAM_Title", "CAM_MultiLineTitle", "CAM_EvenLeneTitle"

● **Select Font Size**

KT_FontSize	Normal	8x 01 70 15 30 FF
	Big	8x 01 70 15 31 FF

(*)Font size default varies by model

Big Size : 11 lines, 43columns

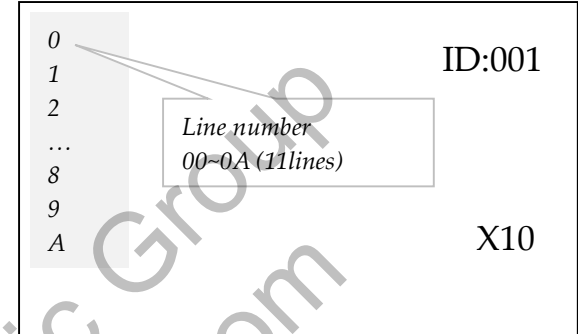

Normal Size : 21 lines, 43 columns

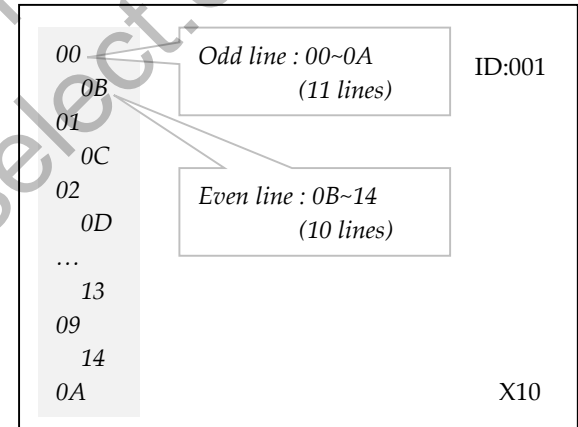

● **Function OSD display**

The current setting status of the camera is displayed on the screen.

CAM_Display	On	8x 01 04 15 02 FF
	Off	8x 01 04 15 03 FF

(example)

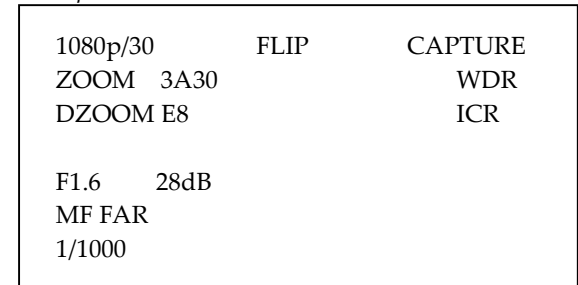

Daisy Chain Connection

- Connection Diagram

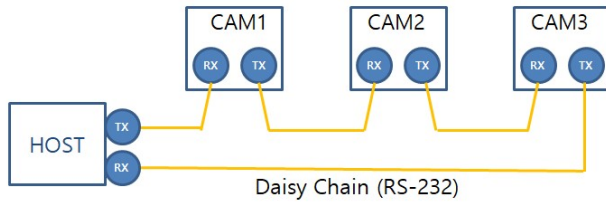

It is recommended to set the camera ID differently.

- VISCA command

KT_DaisyChain	Command	Reply
OFF (Factory Default)	88 40 00 FF	88 40 00 FF
ON	88 40 01 FF	88 40 01 FF

KT_DaisyChainTemp	Command	Reply
OFF	88 41 00 FF	88 41 00 FF
ON	88 41 01 FF	88 41 01 FF

(When the power is turned off, it returns to the original state.
Use it for testing)

- It is a broadcasting command.
- If daisy chain is enabled in multi-protocol mode, only VISCA command is available.

Daisy Chain OFF	VISCA, PELCO,...
Daisy Chain ON	Only VISCA

External Trigger Shutter

The electronic shutter is used synchronized with externally input trigger signals to capture fast-moving objects clearly and in a precise position.

There are two types of external trigger shutter: an external trigger shutter controlled by external input trigger pulse width and a fixed speed external trigger shutter synchronized with the timing of an externally input trigger. We only provide "Fixed external trigger shutter speeds mode".

- Fixed external trigger shutter speeds

60p/30p mode	50p/25p mode
1/30000	1/30000
1/10000	1/10000
1/6000	1/6000
1/4000	1/3500
1/3000	1/2500
1/2000	1/1750
1/1500	1/1250
1/1000	1/1000
1/725	1/600
1/500	1/425
1/350	1/300
1/250	1/215
1/180	1/150
1/125	1/120
1/100	1/100
1/90	1/75
1/60	1/50
1/30	1/25

Trigger Control

- Free run Mode

The camera operates without a trigger signal and performs the video output operation continuously after the exposure is finished. The horizontal and vertical timing signals are generated within the camera.

- Trigger Mode

Exposure is started by detecting the externally input trigger signal. The exposure is started by detecting the trigger signal, and the exposure time is determined by the register(shutter speed) setting. It is recommended to use MANUAL EXPOSURE if possible.

KT_TriggerMode	8x 01 04 70 0p FF	p=0 (All Off) p=2 (Trigger Mode) p=3 (Free run Mode)
----------------	-------------------	--

Trigger Mode Control

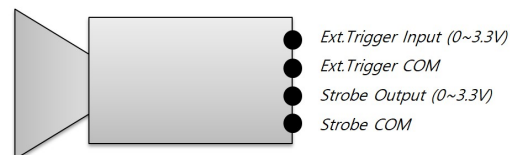

- Normal Trigger Mode

The exposure position is located at an arbitrary point

Actual Zoom/Focus Position

VISCA focus position refers to the distance to the subject, not the actual position of the focus lens.

VISCA zoom position is always 0000~4000, it is not the real zoom lens motor position.

However, the ACTUAL position is the real zoom/focus motor position, and it varies depending on the product.

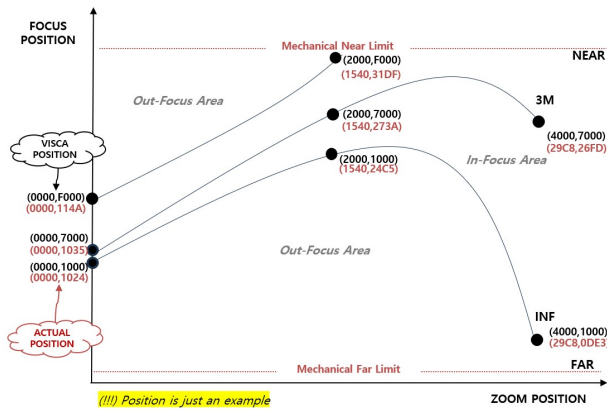

(just example)	VISCA FOCUS STEP	ACTUAL(real) FOCUS STEP
Wide	7000~1000 (24,576 step)	1035-1024 (10 step)
Middle	7000~1000 (24,576 step)	273A-24C5 (629 step)
Tele	7000~1000 (24,576 step)	26FD-0DE3 (6,426 step)

[VISCA POSITION COMMAND]

- Direct Move to VISCA Zoom Position
[81 01 04 47 0z 0z 0z 0z FF]
: normal zoom in/out (In focus while moving)
: zzzz = zoom position
- Direct Move to VISCA Focus Position
[81 01 04 48 0p 0p 0p 0p FF]
: ffff = focus position
- Direct Move to VISCA Position
[81 01 04 47 0z 0z 0z 0z 0f 0f 0f 0f FF]
: In focus while moving
: zzzz(zoom)/ffff(focus)

[81 01 04 47 0z 0z 0z 0z 0f 0f 0f 0f 00 FF]
: Out of focus while moving (fast move)
: zzzz(zoom)/ffff(focus)

- Get VISCA Zoom Position
[81 09 04 47 FF] -> [90 50 0f 0f 0f 0f FF]
- Get VISCA Focus Position
[81 09 04 48 FF] -> [90 50 0z 0z 0z 0z FF]

[ACTUAL POSITION COMMAND]

- Direct Move to Actual Zoom Position
[81 01 71 20 0z 0z 0z 0z FF]
: normal zoom in/out (In focus while moving)
: zzzz = zoom position
- Direct Move to Actual Focus Position
[81 01 71 21 0p 0p 0p 0p FF]
: ffff = focus position
- Direct Move to Actual Position
[81 01 71 20 0z 0z 0z 0z 0f 0f 0f 0f FF]
: In focus while moving
: zzzz(zoom)/ffff(focus)

[81 01 71 20 0z 0z 0z 0z 0f 0f 0f 0f 00 FF]
: Out of focus while moving (fast move)
: zzzz(zoom)/ffff(focus)
- Get Actual Focus Position
[81 09 71 21 FF] -> [90 50 0z 0z 0z 0z FF]
- Get Actual Zoom Position
[81 09 71 20 FF] -> [90 50 0f 0f 0f 0f FF]
- Get Actual/Visca Zoom/Focus Position
[81 09 71 1F 0p FF]->[90 50 0z 0z 0z 0z 0f 0f 0f 0f 0d 0d FF]
: if p=0, get VISCA position
: if p=1, get ACTUAL position
: zzzz=zoom, ffff=focus, dd=digital zoom position

- Get Actual Focus Limit Position for Auto Focus
[81 09 71 23 FF] -> [90 50 0f 0f 0f 0f 0n 0n 0n 0n FF]
: ffff = far limit position for Auto Focus
: nnnn = near limit position for Auto Focus
(This position depends on the zoom position)
- Get Actual Mechanical Limit Focus Position
[81 09 71 26 FF] -> [90 50 0f 0f 0f 0f 0n 0n 0n 0n FF]
: ffff = mechanical far limit position
: nnnn = mechanical near limit position
(This position is the same regardless of the zoom position)

[ACTUAL POSITION]

- Actual Zoom Range
: 0000 ~ 2C80(Optical end) ~ 2D6B (Digital End)
: Digital zoom position = 00 ~ EB
: 2D6B = 2C80(optical) + EB(digital)
- Actual Focus Mechanical Limit
: 0F40(FAR)~1E3C(NEAR)
: The actual auto focusing area varies depending on the zoom position.

COMMAND LIST

Overview of RS232 Communication

- Communication speed :
2400/4800/9600/19200,38400/57600/115200bps
- Data bits : 8
- Start bit : 1
- Stop bit : 1
- Non parity
- Flow control using XON/XOFF and RTS/CTS, etc., is not supported

Command & Inquiry

- **Command**
Sends operational commands to the camera
- **Inquiry**
Used for inquiring about the current state of the camera

Command Packet	Note
Inquiry 8X QQ RR ... FF	QQ ₁)= Command/Inquiry, RR ₂)= category code
	1) QQ = 01 (Command), 09 (Inquiry)
	2) RR = 00 (Interface), 04 (camera 1), 06 (Pan/Tilter), 07 (camera 2)
	X = 1 to 7 : camera address

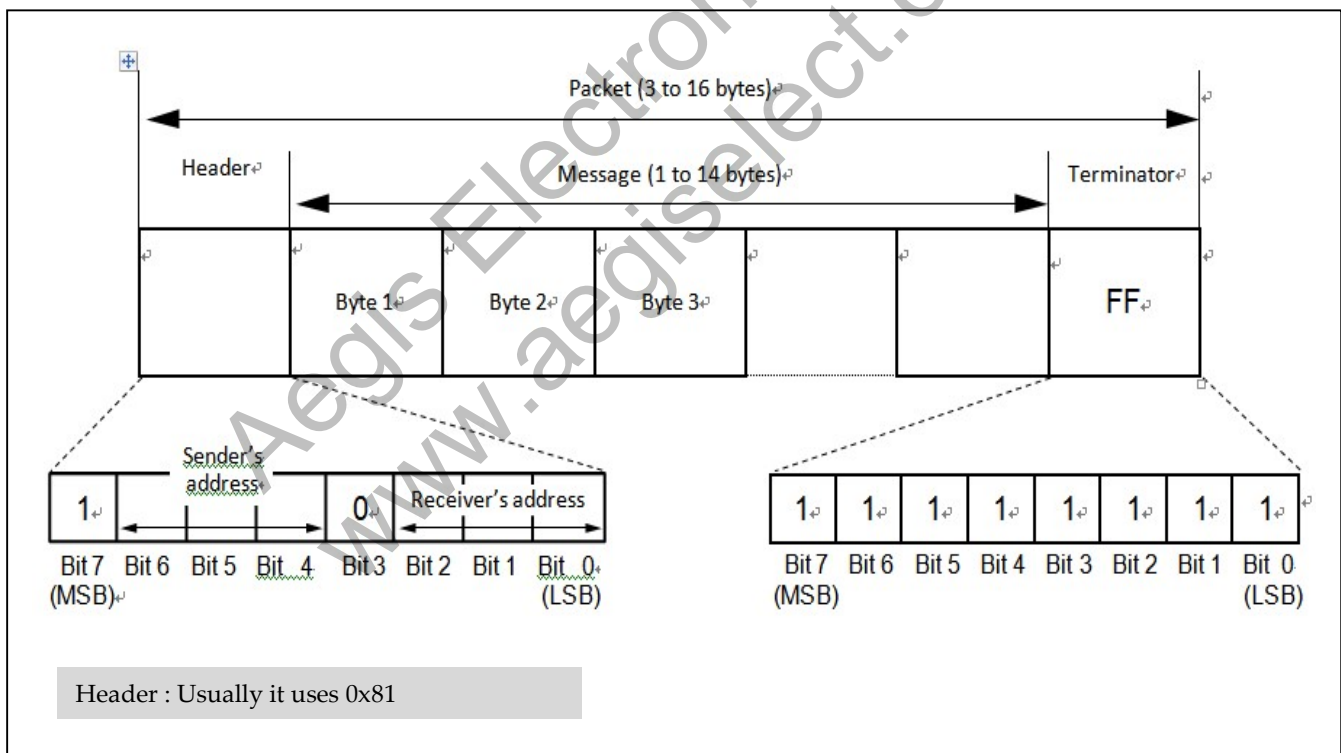

Inquiries

- **ACK message**

Returned by the camera when it receives a command. No ACK message is returned for inquiries.

- **Completion message**

Returned by the camera when execution of commands or inquiries is completed. In the case of inquiry commands, it will contain reply data for the inquiry after the 3rd byte of the packet. If the ACK message is omitted, the socket number will contain 0.

	Reply Packet	Note
Ack	X0 4Y FF	Y = socket
Completion	X0 5Y FF	Y = socket
Completion (Inquiries)	X0 5Y ... FF	Y = socket

X = 9 to F: camera address + 8

- **Network change**

Camera automatically transmits when power is turned on.

Packet

Network change X0 38 FF (X=9)

Command / ACK Example

- **Error message**

Error Packet	Description
X0 6Y 01 FF	Message length error (>14 bytes)
X0 6Y 02 FF	Syntax Error
X0 6Y 03 FF	Command Buffer Full
X0 6Y 04 FF	Command cancelled
X0 6Y 05 FF	No socket
X0 6Y 41 FF	Command not executable

- **Cam_VersionInq**

Returns information on the VISCA interface.

Inquiry	Packet	Reply	Description
Cam_VersionInq	8X 09 00 02 FF	Y0 50 AA BB HH HH JJ JJ KK FF	AA=Zoom Model BB=Camera Model HHHH=FCB Version JJJJ = ROM version KK=Maximum socket # (=02)

X = 1 to 7 : camera address (For inquiry packet)

X = 9 to F : camera address +8 (For reply packet)

Model	AABB	HHHH
ATC-HZ8940T-LTA	7641	046F
ATC-HZ8940T-LP	7640	046F

JJJJ : ex) 0123 = Ver1.2.3

Command	Command Message	Reply Message	Comments
General Command	81 01 04 38 02 FF (Example)	90 41 FF (ACK)+90 51 FF (Completion) 90 42 FF 90 52 FF	Returns ACK when a command has been accepted, and Completion when a command has been executed.
	81 01 04 38 FF (Example)	90 60 02 FF (Syntax Error)	Accepted a command which is not supported or a command lacking parameters.
	81 01 04 08 02 FF (Example)	90 61 41 FF (Command Not Executable) 90 62 41 FF	Could not execute the command in the current mode.
Inquiry Command	81 09 04 38 FF (Example)	90 50 02 FF (Completion)	ACK is not returned for the inquiry command.
	81 09 05 38 FF (Example)	90 60 02 FF (Syntax Error)	Accepted an incompatible command.
AddressSet	88 30 01 FF	88 30 02 FF	Returned the device address to +1.
IF_Clear (Broadcast)	88 01 00 01 FF	88 01 00 01 FF	Returned the same command.
IF_Clear (For x)	8x 01 00 01 FF	z0 50 FF (Completion)	ACK is not returned for this command.

CAMERA COMMAND LIST

Command Set	Command	Command Packet	Comments
CAM_Power	On	8x 01 04 00 02 FF	Power ON/OFF
	Off (Standby)	8x 01 04 00 03 FF	
CAM_Zoom	Stop	8x 01 04 07 00 FF	p=0 (Low) to 7 (High) pqrs: Zoom Position zzzz : zoom position ffff : focus position
	Tele (Standard)	8x 01 04 07 02 FF	
	Wide (Standard)	8x 01 04 07 03 FF	
	Tele (Variable)	8x 01 04 07 2p FF	
	Wide (Variable)	8x 01 04 07 3p FF	
	Direct	8x 01 04 47 0p 0q 0r 0s FF	
	Direct Zoom/Focus	8x 01 04 47 0z 0z 0z 0z 0f 0f 0f 0f FF	
CAM_DZoom	On	8x 01 04 06 02 FF	Digital zoom ON/OFF Optical/Digital Zoom Combined Optical/Digital Zoom Separate p=0 (Low) to 7 (High) * Enabled during Separate Mode x1/MAX Magnification Switchover * Enabled during Separate Mode pq: D-Zoom Position * Enabled during Separate Mode
	Off	8x 01 04 06 03 FF	
	Combine Mode	8x 01 04 36 00 FF	
	Separate Mode	8x 01 04 36 01 FF	
	Stop	8x 01 04 06 00 FF	
	Tele (Variable)	8x 01 04 06 2p FF	
	Wide (Variable)	8x 01 04 06 3p FF	
	x1/Max	8x 01 04 06 10 FF	
	Direct	8x 01 04 46 00 00 0p 0q FF	
CAM_Focus	Stop	8x 01 04 08 00 FF	p=0 (Low) to 7 (High) pqrs: Focus Position AF ON/OFF One Shot pqrs: Focus Near Limit Position
	Far (Standard)	8x 01 04 08 02 FF	
	Near (Standard)	8x 01 04 08 03 FF	
	Far (Variable)	8x 01 04 08 2p FF	
	Near (Variable)	8x 01 04 08 3p FF	
	Direct	8x 01 04 48 0p 0q 0r 0s FF	
	Auto Focus	8x 01 04 38 02 FF	
	Manual Focus	8x 01 04 38 03 FF	
	Auto/Manual	8x 01 04 38 10 FF	
	One Shot	8x 01 04 38 01 FF	
	Near Limit	8x 01 04 28 0p 0q 0r 0s FF	
AF Sensitivity	Normal	8x 01 04 58 02 FF	AF Sensitivity High/Low
	Low	8x 01 04 58 03 FF	
CAM_AFMode	Normal AF	8x 01 04 57 00 FF	AF Movement Mode pq: Movement Time, rs: Interval
	Interval AF	8x 01 04 57 01 FF	
	Zoom Trigger AF	8x 01 04 57 02 FF	
	PRESET (*3)	8x 01 04 57 03 FF	
	Active/Interval Time	8x 01 04 27 0p 0q 0r 0s FF	
CAM_IRCorrection	Standard	8x 01 04 11 00 FF	FOCUS IR compensation data switching
	IR Light	8x 01 04 11 01 FF	
CAM_ZoomFocus	Direct	8x 01 04 47 0p 0q 0r 0s 0t 0u 0v 0w FF	pqrs: Zoom Position tuvw: Focus Position
CAM_Initialize	Lens	8x 01 04 19 01 FF	Lens Initialization Start Camera reset
	Camera	8x 01 04 19 03 FF	
CAM_WB	Auto	8x 01 04 35 00 FF	Normal Auto
	Indoor	8x 01 04 35 01 FF	Indoor mode
	Outdoor	8x 01 04 35 02 FF	Outdoor mode
	One Push WB	8x 01 04 35 03 FF	One Push WB mode
	ATW	8x 01 04 35 04 FF	Auto Tracing White Balance
	Manual	8x 01 04 35 05 FF	Manual Control mode
CAM_RGain	Reset	8x 01 04 03 00 FF	Manual Control of R Gain pq: R Gain, 0x00~0xff
	Up	8x 01 04 03 02 FF	
	Down	8x 01 04 03 03 FF	
	Direct	8x 01 04 43 00 00 0p 0q FF	
CAM_BGain	Reset	8x 01 04 04 00 FF	Manual Control of B Gain
	Up	8x 01 04 04 02 FF	
	Down	8x 01 04 04 03 FF	

	Direct	8x 01 04 44 00 00 0p 0q FF	pq: B Gain, 0x00~0xff	
CAM_AE	Full Auto	8x 01 04 39 00 FF	Automatic Exposure mode	
	Manual	8x 01 04 39 03 FF	Manual Control mode	
	Shutter Priority	8x 01 04 39 0A FF	Shutter Priority Automatic Exposure mode	
	Iris Priority	8x 01 04 39 0B FF	Iris Priority Automatic Exposure mode	
	Bright	8x 01 04 39 0D FF	Bright Mode (Active only Auto, Shutter mode)	
CAM_SlowShutter	Auto	8x 01 04 5A 02 FF	Auto Slow Shutter ON/OFF	
	Manual	8x 01 04 5A 03 FF		
CAM_Shutter	Reset	8x 01 04 0A 00 FF	Shutter Setting	
	Up	8x 01 04 0A 02 FF		
	Down	8x 01 04 0A 03 FF		
	Direct	8x 01 04 4A 00 00 0p 0q FF		pq: Shutter Position
CAM_Iris	Reset	8x 01 04 0B 00 FF	Iris Setting	
	Up	8x 01 04 0B 02 FF		
	Down	8x 01 04 0B 03 FF		
	Direct	8x 01 04 4B 00 00 0p 0q FF		pq: Iris Position
CAM_Gain	Reset	8x 01 04 0C 00 FF	Gain Setting	
	Up	8x 01 04 0C 02 FF		
	Down	8x 01 04 0C 03 FF		
	Direct	8x 01 04 4C 00 00 0p 0q FF		pq: Gain Position, 0x00~0x09, See GAIN POS.
	Gain Limit	8x 01 04 2C pp FF		pp: Gain Position, 0x00~0x09, See GAIN LIMIT
CAM_Bright	Reset	8x 01 04 0D 00 FF	Bright Setting	
	Up	8x 01 04 0D 02 FF		
	Down	8x 01 04 0D 03 FF		
	Direct	8x 01 04 4D 00 00 0p 0q FF		pq: Bright Position
CAM_ExpComp	On	8x 01 04 3E 02 FF	Exposure Compensation ON/OFF	
	Off	8x 01 04 3E 03 FF		
	Reset	8x 01 04 0E 00 FF		Exposure Compensation Amount Setting
	Up	8x 01 04 0E 02 FF		
	Down	8x 01 04 0E 03 FF		
Direct	8x 01 04 4E 00 00 0p 0q FF	pq: ExpComp Position, 0x00~0x0E		
CAM_BackLight	On	8x 01 04 33 02 FF	Back Light Compensation ON/OFF	
	Off	8x 01 04 33 03 FF		
CAM_AE_Response ^(*)	Direct	8x 01 04 5D pp FF	pp: Automatic Exposure Response Setting (00 to 254), default value: 64	
CAM_WD	On	8x 01 04 3D 02 FF	Wide-D ON/OFF	
	Off	8x 01 04 3D 03 FF		
	Set Parameter	8x 01 04 2D 00 00 00 0s 00 00 00 00 FF		s: Blown-out highlight correction level (0:low, 1:middle, 2:high)
CAM_Aperture (sharpness level)	Reset	8x 01 04 02 00 FF	Aperture Control (sharpness)	
	Up	8x 01 04 02 02 FF		
	Down	8x 01 04 02 03 FF		
	Direct	8x 01 04 42 00 00 0p 0q FF		pq: Aperture Gain (0x00~0x0F)
CAM_HR	On	8x 01 04 52 02 FF	High-Resolution Mode ON/OFF	
	Off	8x 01 04 52 03 FF		
CAM_NR	-	8x 01 04 53 0p FF	p: NR Setting (0: OFF, level 1 to 3)	
CAM_Gamma	-	8x 01 04 5B 0p FF	p: GAMMA setting (0: Standard, 1 to 3) See. GAMMA POSITION	
CAM_LR_Reverse	On	8x 01 04 61 02 FF	Mirror Image ON/OFF	
	Off	8x 01 04 61 03 FF		
CAM_Freeze	On	8x 01 04 62 02 FF	Still Image ON/OFF	
	Off	8x 01 04 62 03 FF		
CAM_PictureEffect	Off	8x 01 04 63 00 FF	Picture Effect Setting (* do not support neg.art)	
	Neg.Art	8x 01 04 63 02 FF		
	B&W	8x 01 04 63 04 FF		
CAM_PictureFlip	On	8x 01 04 66 02 FF	Picture flip ON/OFF	
	Off	8x 01 04 66 03 FF		
CAM_ICR	On	8x 01 04 01 02 FF	Infrared Mode ON(night)/OFF(day)	
	Off	8x 01 04 01 03 FF		
CAM_AutoICR	On	8x 01 04 51 02 FF	Auto dark-field mode On/Off	
	Off	8x 01 04 51 03 FF		
	Threshold	8x 01 04 21 00 00 0p 0q FF		pq: ICR ON → OFF Threshold Level (Night->Day)
	Threshold ^(*)	8x 01 04 41 00 00 0p 0q FF		pq: ICR OFF → ON Threshold Level (Day->Night)
CAM_AutoICRAlarmReply ^(*)	On	8x 01 04 31 02 FF	Auto ICR switching Alarm ON/OFF	
	Off	8x 01 04 31 03 FF		
	(Reply)	y0 07 04 31 02 FF		ICR OFF → ON (Night->Day)

		y0 07 04 31 03 FF	ICR ON → OFF (Day->Night)
CAM_MemSave	Write	8x 01 04 23 0X 0p 0p 0q 0q FF	X: 00 to 07 (Address), total 16 byte ppqq: 0x0000 to 0xFFFF (Data)
CAM_Display (*2)	On	8x 01 04 15 02 FF (8x 01 06 06 02 FF)	Display ON/OFF (function OSD display)
	Off	8x 01 04 15 03 FF (8x 01 06 06 03 FF)	Function OSD : - Display item : Zoom Ratio, Camera ID
	On/Off	8x 01 04 15 10 FF (8x 01 06 06 10 FF)	Framerate, AE mode, WB mode, Exposure Data
CAM_Title (*2) Total 21 lines See. "Title/Function display"	Title Set1	8x 01 04 73 00 mm nn pp qq 00 00 00 00 00 00 FF	mm : V-position(0x00~0x14) , nn:H-position (00~28) pp:color, qq:blink
	Title Set2	8x 01 04 73 01 mm nn pp qq rr ss tt uu vv ww FF	mm~ww : setting of display characters (1st to 10st)
	Title Set3	8x 01 04 73 02 mm nn pp qq rr ss tt uu vv ww FF	mm~ww : setting of display characters (11st to 20st)
	Title Set4	8x 01 04 73 07 01 02 03 04 05 06 07 08 09 10 11 12 13 14 15 16 17 18 19 20 21 22 23 24 25 26 27 28 29 30 32 33 34 35 36 37 38 39 40 41 42 43 FF	mm~ww : setting of display characters (1~ 43)
	Title Clear	8x 01 04 74 00 FF	Title Setting Clear (clear all lines)
	On	8x 01 04 74 02 FF	Title Display On (display all lines)
	Off	8x 01 04 74 03 FF	Title Display Off (display off all lines)
	CAM_MultiLineTitle(*2) See. "Title/Function display" (Big Font or Normal Font Odd Line) L = 0x0 = Line 00 0x1 = Line 01 ... 0x9 = Line 09 0xA = Line 0A	Title Set1	8x 01 04 73 1L 00 nn pp qq 00 00 00 00 00 00 FF
Title Set2		8x 01 04 73 2L mm nn pp qq rr ss tt uu vv ww FF	L: Line Number (0x0~0xA) mnpqrstuvw: Setting of characters (1 to 10)
Title Set3		8x 01 04 73 3L mm nn pp qq rr ss tt uu vv ww FF	L: Line Number (0x0~0xA) mnpqrstuvw: Setting of characters (11 to 20)
Title Set4		8x 01 04 73 7L 01 02 03 04 05 06 07 08 09 10 11 12 13 14 15 16 17 18 19 20 21 22 23 24 25 26 27 28 29 30 32 33 34 35 36 37 38 39 40 41 42 43 FF	L: Line Number (0x0~0xA) 01~30 : Setting of characters (1 to 43)
Title Clear		8x 01 04 74 1p FF	Title Clear, Display On/Off
On		8x 01 04 74 2p FF	p:0x0~0xA, F= all lines (line 00~0A)
Off		8x 01 04 74 3p FF	
CAM_EvenLineTitle(*4) See. "Title/Function display" (Normal Font Even Line) L = 0x0 = Line 0B 0x1 = Line 0C ... 0x8 = Line 13 0x9 = Line 14	Title Set1A	8x 01 04 73 4L 00 nn pp qq 00 00 00 00 00 00 FF	L: Line Number (0x0~0x9) nn: H-position → nn : 00~0x28 pp: Color, qq: Blink
	Title Set2A	8x 01 04 73 5L mm nn pp qq rr ss tt uu vv ww FF	L: Line Number (0x0~0x9) mnpqrstuvw: Setting of characters (1 to 10)
	Title Set3A	8x 01 04 73 6L mm nn pp qq rr ss tt uu vv ww FF	L: Line Number (0x0~0x9) mnpqrstuvw: Setting of characters (11 to 20)
	Title Set4A	8x 01 04 73 8L 01 02 03 04 05 06 07 08 09 10 11 12 13 14 15 16 17 18 19 20 21 22 23 24 25 26 27 28 29 30 32 33 34 35 36 37 38 39 40 41 42 43 FF	L: Line Number (0x0~0x9) 01~30 : Setting of characters (1 to 43)
	Title Clear	8x 01 04 74 4p FF	Title Clear, Display On/Off
	On	8x 01 04 74 5p FF	p:0x0~0x9, F= all lines (line 0B ~ 14)
	Off	8x 01 04 74 6p FF	
CAM_Mute	On	8x 01 04 75 02 FF	Muting ON/OFF
	Off	8x 01 04 75 03 FF	
	On/Off	8x 01 04 75 10 FF	
CAM_PrivacyZone	SetMask	8x 01 04 76 mm nn 0r 0r 0s 0s FF	mm: Mask Settings nn 00: Modify, 01: New rr: W, ss: H
	Display(*2)	8x 01 04 77 pp pp pp pp FF	Mask Display ON/OFF pp pp pp pp: Mask Settings (0: OFF, 1: ON)
	SetMaskColor	8x 01 04 78 pp pp pp pp qq rr FF	pp pp pp pp: Mask Color Settings qq: Color Setting when 0 is selected rr: Color Setting when 1 is selected

	SetPanTiltAngle	8x 01 04 79 0p 0p 0p 0q 0q 0q FF	Pan/Tilt Angle Settings ppp: Pan qqq: Tilt
	SetPTZMask	8x 01 04 7B mm 0p 0p 0p 0q 0q 0q 0r 0r 0r 0r FF	Pan/Tilt/Zoom Settings for Mask ppp: Pan, qqq: Tilt, rrrr: Zoom
	Non_InterlockMask	8x 01 04 6F mm 0p 0p 0q 0q 0r 0r 0s 0s FF	mm: Non_Interlock Mask Settings pp: X, q: Y, rr: W, ss: H
CAM_IDWrite	—	8x 01 04 22 00 00 0p 0q FF	pq: Camera ID (=0 to 255)
CAM_MD	On	8x 01 04 1B 02 FF	Motion Detection On/Off
	Off	8x 01 04 1B 03 FF	
	Function Set	8x 01 04 1C 0m 0n 0p 0q 0r 0s FF	m: Display mode (when motion is detected) 0 : OFF 1 : WINDOW display 2 : Text display 3: WINDOW & Text display n: Detection Frame Set (0 to F) bit0(frame1)-bit3(frame4) pq: Threshold Level (00 to FF) rs: Interval Time set (00 to FF)
	Window Set	8x 01 04 1D 0m 0p 0q rr 0s FF	m: Select Detection Frame (0, 1, 2, 3) p: Start Horizontal Position (00 to 0F) q: Start Vertical Position (00 to 07) r: Stop Horizontal Position (01 to 10) s: Stop Vertical Position (01 to 08)
	Alarm (Reply)	y0 07 04 1B 0p FF	p: Detection Frame Number
CAM_Continuous ZoomPosReply ^(*)	On	8x 01 04 69 02 FF	ZoomPosition data Continuous Output On/Off
	Off	8x 01 04 69 03 FF	
	(Reply)	y0 07 04 69 0p 0p 0q 0q 0q FF	pp: D-Zoom Position * 00: When Zoom Mode is Combine qqq: Zoom Position
CAM_ZoomPos ReplyIntervalTimeSet ^(*)	—	8x 01 04 6A 00 00 0p 0p FF	pp: 01 to FF Zoom Position continuous output Interval Time [Vertical timing]
CAM_Continuous FocusPosReply ^(*)	On	8x 01 04 16 02 FF	Focus Position data Continuous Output On/Off
	Off	8x 01 04 16 03 FF	
	(Reply)	y0 07 04 16 00 00 0p 0p 0p FF	pppp: Focus Position
CAM_FocusPos ReplyIntervalTimeSet ^(*)	—	8x 01 04 1A 00 00 0p 0p FF	pp: : 01 to FF Focus Position continuous output Interval Time [Vertical timing]
CAM_ExtAutoICR_thresh old ^(*)	ICR ON → OFF	8x 01 04 1F 21 00 00 0p 0q FF	pq : ICR ON → OFF threshold when Auto ICR is on pq = 00h ~ 1Bh (Night → Day threshold)
	ICR OFF → ON	8x 01 04 1F 21 01 00 0p 0q FF	pq : ICR OFF → ON threshold when Auto ICR is on pq = 01h ~ 1Ch (Day → Night threshold)
CAM_RegisterValue	—	8x 01 04 24 mm 0p 0p FF	mm: Register No. (=00-7F) pp: Register Value (=00-7F) See the "Register setting"
CAM_ColorGain	Direct	8x 01 04 49 00 00 00 0p FF	p: Color Gain setting 0h (60%) to Eh (200%)
CAM_ColorHue	Direct	8x 01 04 4F 00 00 00 0p FF	p: Color Hue setting 0h (- 14 degrees) to Eh (+14 degrees)
CAM_Stablizer	On	8x 01 04 34 02 FF	Digital Image Stabilizer
	Off	8x 01 04 34 03 FF	
CAM_Defog	On	8x 01 04 37 02 0p FF	Defog On/Off p:defog level(0:low,1:middle,2:high)
	Off	8x 01 04 37 03 0p FF	
CAM_HLC ^(*)	Parameter Set	8x 01 04 14 0p 0q FF	p:HLC Level (0:Off, 1:On) q:HLC mask level(0:Off, 1(low)-F(high)
CAM_SpotAE ^(*)	On	8x 01 04 59 02 FF	Spot AE mode
	Off	8x 01 04 59 03 FF	
	Position	8x 01 04 29 00 0p 00 0q FF	
CAM_Memory ^(*)	Reset	8x 01 04 3F 00 0p FF	p:Memory Number(0~F) (See. Custom/Memory Preset Setting Items)
	Set	8x 01 04 3F 01 0p FF	
	Recall	8x 01 04 3F 02 0p FF	
CAM_Custom ^(*)	Reset	8x 01 04 3F 00 7F FF	Starts up in this mode when the power is turned on (*)The SET command must be sent one time to activate the custom preset. (*) Inactive : When the power is turned on, it starts up in the settings before the power is turned off. (See. Custom/Memory Preset Setting Items)
	Set	8x 01 04 3F 01 7F FF	
	Recall	8x 01 04 3F 02 7F FF	
	Inactive	8x 01 04 3F 10 7F FF	
	Active	8x 01 04 3F 11 7F FF	

CAM_AWBSpeed ^(*)	Direct	8x 01 04 56 pp FF	pp: Automatic AWB Speed Setting (00 to FE), default value: 0xE0
ICT Display	On	8x 01 71 B8 01 FF	ICT Display On/Off
	Off	8x 01 71 B8 00 FF	
ICR auto refresh		8x 01 71 1C qq FF	ICR auto refresh disable : q=0 ICR auto refresh enable : qq=01(1sec) ~ FE(254sec)
KT_KeyAct	Stop	8x 01 70 01 00 FF	
	Up	8x 01 70 01 21 FF	
	Down	8x 01 70 01 22 FF	
	Left	8x 01 70 01 23 FF	
	Right	8x 01 70 01 24 FF	
	Set	8x 01 70 01 26 FF	Enter Key
	Menu Off	8x 01 70 01 27 FF	Menu Off
	Factory Default	8x 01 70 01 0F FF	Initialize Camera Data
	Auto Zoom	8x 01 70 01 20 FF	Repeat TELE ~ WIDE. To stop, send the Auto Zoom command
	Auto Zoom 1 time	8x 01 70 01 1F FF	
KT_DayNightMode	Auto	8x 01 70 04 00 FF	
	Day	8x 01 70 04 01 FF	
	Night	8x 01 70 04 02 FF	
	External-High	8x 01 70 04 03 FF	Night = Ext. input level is High
	External-Low	8x 01 70 04 04 FF	Night = Ext. input level is Low
KT_ExtICRthreshold (Ext.H or Ext.L mode)	Day->Night(EXT-H)	8x 01 70 05 10 p 0q FF	pq: ICR OFF→ON Threshold Level (Day->Night)
	Night->Day(EXT-H)	8x 01 70 05 11 p 0q FF	pq: ICR ON→OFF Threshold Level (Night->Day)
	Day->Night(EXT-L)	8x 01 70 05 20 p 0q FF	pq: ICR OFF→ON Threshold Level (Day->Night)
	Night->Day(EXT-L)	8x 01 70 05 21 p 0q FF	pq: ICR ON→OFF Threshold Level (Night->Day)
KT_AutoICRdelay	Delay Time	8x 01 04 41 01 00 0p 0q FF	pq: sec (0~60sec)
KT_AE_Brightness;	Level	8x 01 70 30 00 0p FF	p : AE Brightness Level (0x00~0x0E)
KT_AgcAutoLimit	-	8x 01 70 34 pp FF	pp :AGC Max Limit (0x00~0xFF)
KT_Sharpness	-	8x 01 70 53 0p FF	p:sharpness level (0x00~0x0E)
KT_MaxField	-	8x 01 70 31 00 0p FF	p : AE Sens up (0-5)
KT_SetNearFarLimit	-	8x 01 71 24 0p FF	P : 0 (full) / 1 (limit)
KT_ZmSpeed	Speed	8x 01 70 51 0p FF	p : Speed (0~7)
KT_ZoomDirectActual	-	8x 01 71 20 0p 0q 0r 0z FF	pqrz : Zoom Position (See. Actual Zoom/focus position)
KT_ZoomFocusDirectActual	-	8x 01 71 20 0z 0z 0z 0z 0f 0f 0f FF	zzzz : Zoom Position ffff : Focus Position (See. Actual Zoom/focus position)
KT_FocusDirectActual	-	8x 01 71 21 0p 0q 0r 0z FF	pqrz : Focus Position (See. Actual Zoom/focus position)

Inquiry Command List

Inquiry Command	Command Packet	Inquiry Packet	Comments
CAM_PowerInq	8x 09 04 00 FF	y0 50 02 FF	On
		y0 50 03 FF	Off (Standby)
CAM_ZoomPosInq	8x 09 04 47 FF	y0 50 0p 0q 0r 0s FF	pqrs: Zoom Position
CAM_DZoomModeInq	8x 09 04 06 FF	y0 50 02 FF	D-Zoom On
		y0 50 03 FF	D-Zoom Off
CAM_DZoomC/SModeInq	8x 09 04 36 FF	y0 50 00 FF	Combine Mode
		y0 50 01 FF	Separate Mode
CAM_DZoomPosInq	8x 09 04 46 FF	y0 50 00 00 0p 0q FF	pq: D-Zoom Position
CAM_FocusModeInq	8x 09 04 38 FF	y0 50 02 FF	Auto Focus
		y0 50 03 FF	Manual Focus
CAM_FocusPosInq	8x 09 04 48 FF	y0 50 0p 0q 0r 0s FF	pqrs: Focus Position
CAM_FocusNearLimitInq	8x 09 04 28 FF	y0 50 0p 0q 0r 0s FF	pqrs: Focus Near Limit Position
CAM_AFMModeInq	8x 09 04 57 FF	y0 50 00 FF	Normal AF
		y0 50 01 FF	Interval AF
		y0 50 02 FF	Zoom Trigger AF
CAM_AFTimeSettingInq	8x 09 04 27 FF	y0 50 0p 0q 0r 0s FF	pq: Movement Time, rs: Interval
CAM_IRCorrectionInq	8x 09 04 11 FF	y0 50 00 FF	Standard
		y0 50 01 FF	IR Light
CAM_WBModeInq	8x 09 04 35 FF	y0 50 00 FF	Auto
		y0 50 01 FF	In Door
		y0 50 02 FF	Out Door
		y0 50 03 FF	One Push WB

		y0 50 04 FF	ATW
		y0 50 05 FF	Manual
CAM_RGainInq	8x 09 04 43 FF	y0 50 00 00 0p 0q FF	pq: R Gain
CAM_BGainInq	8x 09 04 44 FF	y0 50 00 00 0p 0q FF	pq: B Gain
CAM_AEModeInq	8x 09 04 39 FF	y0 50 00 FF	Full Auto
		y0 50 03 FF	Manual
		y0 50 0A FF	Shutter Priority
		y0 50 0B FF	Iris Priority
		y0 50 0D FF	Bright
CAM_ShutterPosInq	8x 09 04 4A FF	y0 50 00 00 0p 0q FF	pq: Shutter Position
CAM_IrisPosInq	8x 09 04 4B FF	y0 50 00 00 0p 0q FF	pq: Iris Position
CAM_GainPosInq	8x 09 04 4C FF	y0 50 00 00 0p 0q FF	pq: Gain Position
CAM_GainLimitInq	8x 09 04 2C FF	y0 50 0q FF	p: Gain Limit
CAM_ExpCompModeInq	8x 09 04 3E FF	y0 50 02 FF	On
		y0 50 03 FF	Off
CAM_ExpCompPosInq	8x 09 04 4E FF	y0 50 00 00 0p 0q FF	pq: ExpComp Position
CAM_BackLightModeInq	8x 09 04 33 FF	y0 50 02 FF	On
		y0 50 03 FF	Off
CAM_AE_ResponseInq	8x 09 04 5D FF	y0 50 pp FF	pp: 01 to 30 (hex)
CAM_WDModeInq	8x 09 04 3D FF	y0 50 02 FF	On Wide-D
		y0 50 03 FF	Off
CAM_WDParameterInq	8x 09 04 2D FF	y0 50 00 00 00 0s 00 00 00 00 FF	s: Blown-out highlight correction level
CAM_ApertureInq	8x 09 04 42 FF	y0 50 00 00 0p 0q FF	pq: Aperture Gain
CAM_HRModeInq	8x 09 04 52 FF	y0 50 02 FF	On (Hi-Resolution)
		y0 50 03 FF	Off
CAM_NRModeInq	8x 09 04 53 FF	y0 50 0p FF	Noise Reduction p: 0 to 3
CAM_GammaInq	8x 09 04 5B FF	y0 50 0p FF	Gamma p: 0 to 3
CAM_LR_ReverseModeInq	8x 09 04 61 FF	y0 50 02 FF	On
		y0 50 03 FF	Off
CAM_FreezeModeInq	8x 09 04 62 FF	y0 50 02 FF	On
		y0 50 03 FF	Off
CAM_PictureEffectModeInq	8x 09 04 63 FF	y0 50 00 FF	Off
		y0 50 02 FF	Neg.Art
		y0 50 04 FF	B&W
CAM_PictureFlipModeInq	8x 09 04 66 FF	y0 50 02 FF	On
		y0 50 03 FF	Off
CAM_ICRModeInq	8x 09 04 01 FF	y0 50 02 FF	On
		y0 50 03 FF	Off
CAM_AutoICRModeInq	8x 09 04 51 FF	y0 50 02 FF	On
		y0 50 03 FF	Off
CAM_AutoICRThresholdInq	8x 09 04 21 FF	y0 50 00 00 0p 0q FF	pq: ICR ON → OFF Threshold Level
CAM_MuteModeInq	8x 09 04 75 FF	y0 50 02 FF	On
		y0 50 03 FF	Off
CAM_VersionInq	8x 09 00 02 FF	y0 50 aa bb mn pq rs tu vw FF	aa: ZOOM model version bb: Camera Model mnpq: FCB Camera Version (04xx) rstu: ROM version vw: Socket Number (=02) See. "Cam_VersionInq"
CAM_MDModeInq	8x 09 04 1B FF	y0 50 02 FF	On
		y0 50 03 FF	Off
CAM_MDFunctionInq	8x 09 04 1C FF	y0 50 0m 0n 0p 0q 0r 0s FF	m: Display mode n: Detection Frame Set (0 to F) pq: Threshold Level (0 to FF) rs: Interval Time set (0 to FF)
CAM_MDWindowInq	8x 09 04 1D 0m FF	y0 50 0p 0q 0r 0s FF	m: Select Detection Frame (0, 1, 2, 3) p: Start Horizontal Position (00 to 0B) q: Start Vertical Position (00 to 07) r: Stop Horizontal Position (01 to 0C) s: Stop Vertical Position (01 to 08)
CAM_ContinuousFocusPosReplyModeInq (*)	8x 09 04 16 FF	y0 50 02 FF	On
		y0 50 03 FF	Off
CAM_ExAutoICRThresholdInq (*)	8x 09 04 1F 21 00 FF	y0 50 00 00 0p 0q FF	pq : ICR ON → OFF threshold when Auto ICR is on (Night → Day)
CAM_ExAutoICRONLevelInq	8x 09 04 1F 21 01 FF	y0 50 00 00 0p 0q FF	pq : ICR OFF → ON threshold when Auto ICR

(*)2			is on (Day → Night)
CAM_RegisterValueInq	8x 09 04 24 mm FF	y0 50 0p 0p FF	mm: Register No. (00 to 7F) pp: Register Value (00 to FF)
CAM_ColorGainInq	8x 09 04 49 FF	y0 50 00 00 00 0p FF	p: Color Gain setting 0h (60%) to Eh (200%)
CAM_ColorHueInq	8x 09 04 4F FF	y0 50 00 00 00 0p FF	p: Color Hue setting 0h (- 14 degrees) to Eh (+ 14 degrees)
CAM_StabilizerInq	8x 09 04 34 FF	y0 50 02 FF	Stabilizer(DIS) on
		y0 50 03 FF	Stabilizer(DIS) off
CAM_DefogInq	8x 09 04 37 FF	y0 50 02 0p FF	Defog On, p:defog level(0:low,1:middle,2:high)
		y0 50 03 00 FF	Defog Off
CAM_HLCInq	8x 09 04 14 FF	y0 50 0p 0q FF	p:HLC Level (0:Off, 1:On) q:HLC mask level(0:Off, 1(low)~F(high)
CAM_SpotAEModeInq	8x 09 04 59 FF	y0 50 02 FF	Spot AE on
		y0 50 03 FF	Spot AE Off
CAM_SpotAEPosInq	8x 09 04 29 FF	y0 50 0p 0q 0r 0s FF	pq:X(0~F), rs:Y(0~F)
CAM_MemoryInq	8x 09 04 3F FF	y0 50 pp FF	pp:memory number recalled last
KT_MenuOnOffInq	8x 09 70 01 FF	y0 50 02 FF	Menu on
		y0 50 03 FF	Menu off
KT_DayNightModeInq	8x 09 70 04 FF	y0 50 0p 0q FF	pq: day&night mode
KT_ExtICRthresholdInq	8x 09 70 05 10 FF	y0 50 0p 0q FF	pq:ext-H day->night threshold
		y0 50 0p 0q FF	pq:ext-H night->day threshold
	8x 09 70 05 20 FF	y0 50 0p 0q FF	pq:ext-L day->night threshold
		y0 50 0p 0q FF	pq:ext-L night->day threshold
KT_AgcAutoLimitInq	8x 09 70 34 FF	y0 50 pp FF	pp:AGC Max Limit (See. GAIN LIMIT table)
KT_SharpnessInq	8x 09 70 53 FF	y0 50 0p FF	p:sharpness level (0x00-0x0F)
KT_ZmSpeedInq	8x 09 70 51 FF	y0 50 0p FF	p : Zoom speed (0-7)
KT_AE_BrightnessInq	8x 09 70 30 FF	y0 50 00 0p FF	p : Brigtness level (0x00-0x0E)
KT_MaxFieldInq	8x 09 70 31 FF	y0 50 0p FF	p : AE Sens up (0-5)
KT_ZoomActualPosInq	8x 09 71 20 FF	y0 50 0p 0q 0r 0z FF	pqrz : Actual Zoom Position
KT_FocusActualPosInq	8x 90 71 21 FF	y0 50 0p 0q 0r 0z FF	pqrz : Actual Focus Position
KT_ActualPosInq	8x 90 71 22 FF	y0 50 0z 0z 0z 0z 0f 0f 0f 0f	zzzz : Actual zoom position
		0d 0d FF	ffff : Actual focus position
			dd : Digital zoom position
KT_GetAfAcualFocusAreaInq	8x 90 71 23 FF	y0 50 0f 0f 0f 0f 0n 0n 0n 0n FF	ffff(far limit) ~ nnnn(near limit)
KT_GetMechanicalActualFocusLimitInq	8x 90 71 26 FF	y0 50 0f 0f 0f 0f 0n 0n 0n 0n FF	ffff(far limit) ~ nnnn(near limit)
KT_GetAcualZoomLimitInq	8x 90 71 27 FF	y0 50 00 00 00 00 0t 0t 0t 0t FF	tttt(optical zoom limit position)

Lens Control System Inquiry Commands Command Packet 8x 09 7E 7E 00 FF

Byte	Bit	Comments
0	7	Destination Address
	6	
	5	
	4	
	3	Source Address
	2	
	1	
	0	
1	7	0 Completion Message
	6	1
	5	0
	4	1
	3	0
	2	0
	1	0
	0	0
2	7	0
	6	0
	5	0
	4	0
	3	Zoom Position (HH)
	2	
	1	
	0	
3	7	0
	6	0
	5	0
	4	0
	3	Zoom Position (HL)
	2	
	1	
	0	
4	7	0
	6	0
	5	0
	4	0
	3	Zoom Position (LH)
	2	
	1	
	0	
5	7	0
	6	0
	5	0
	4	0
	3	Zoom Position (LL)
	2	
	1	
	0	

Byte	Bit	Comments
6	7	0
	6	0
	5	0
	4	0
	3	Focus Near Limit (H)
	2	
	1	
	0	
7	7	0
	6	0
	5	0
	4	0
	3	Focus Near Limit (L)
	2	
	1	
	0	
8	7	0
	6	0
	5	0
	4	0
	3	Focus Position (HH)
	2	
	1	
	0	
9	7	0
	6	0
	5	0
	4	0
	3	Focus Position (HL)
	2	
	1	
	0	
10	7	0
	6	0
	5	0
	4	0
	3	Focus Position (LH)
	2	
	1	
	0	
11	7	0
	6	0
	5	0
	4	0
	3	Focus Position (LL)
	2	
	1	
	0	

Byte	Bit	Comment
12	7	0
	6	0
	5	0
	4	0
	3	0
	2	0
	1	0
	0	0
13	7	0
	6	0
	5	DZoomMode 0: Combine 1: Separate
	4	0: Normal 1: Interval 2: Zoom Trigger
	3	
	2	AF Sensitivity 0: Slow 1: Normal
	1	Digital Zoom 1: On 0: Off
	0	Focus Mode 0: Manual 1: Auto
	7	0
	6	0
	5	0
	4	0
	3	0
2	0	
14	1	Focus Command 1: Executing 0: Stopped
	0	Zoom Command 1: Executing 0: Stopped
	7	1 Terminator (FFh)
15	6	1
	5	1
	4	1
	3	1
	2	1
	1	1
	0	1

Camera Control System Inquiry Commands Command Packet 8x 09 7E 7E 01 FF

Byte	Bit	Comments
0	7	Destination Address
	6	
	5	
	4	
	3	Source Address
	2	
	1	
	0	
1	7	0 Completion Message
	6	1
	5	0
	4	1
	3	0
	2	0
	1	0
	0	0
2	7	0
	6	0
	5	0
	4	0
	3	R Gain (H)
	2	
	1	
	0	
3	7	0
	6	0
	5	0
	4	0
	3	R Gain (L)
	2	
	1	
	0	
4	7	0
	6	0
	5	0
	4	0
	3	B Gain (H)
	2	
	1	
	0	
5	7	0
	6	0
	5	0
	4	0
	3	B Gain (L)
	2	
	1	
	0	

Byte	Bit	Comments
6	7	0
	6	0
	5	0
	4	0
	3	WB Mode
	2	
	1	
	0	
7	7	0
	6	0
	5	0
	4	0
	3	Aperture Gain
	2	
	1	
	0	
8	7	0
	6	0
	5	0
	4	Exposure Mode
	3	
	2	
	1	
	9	7
6		0
5		High-Resolution 1: On 0: Off
4		Wide-D (1: Other than Off, 0: Off)
3		0
2		Back Light 1: On 0: Off
1		Exposure Comp. 1: On 0: Off
0		Slow Shutter 1: Auto 0:
10	7	0
	6	0
	5	0
	4	Shutter Position
	3	
	2	
	1	
	11	7
6		0
5		0
4		Iris Position
3		
2		
1		
0		

Byte	Bit	Comments
12	7	0
	6	0
	5	0
	4	0
	3	Gain Position
	2	
	1	
	0	
13	7	0
	6	0
	5	0
	4	Bright Position
	3	
	2	
	1	
	14	7
6		0
5		0
4		0
3		Exposure Comp. Position
2		
1		
0		
15	7	1 Terminator (FFh)
	6	1
	5	1
	4	1
	3	1
	2	1
	1	1
	0	1

Other Inquiry Commands Command Packet 8x 09 7E 7E 02 FF

Byte	Bit	Comments
0	7	Destination Address
	6	
	5	
	4	
	3	Source Address
	2	
	1	
	0	
1	7	0 Completion Message
	6	1
	5	0
	4	1
	3	0
	2	0
	1	0
	0	0
2	7	0
	6	0
	5	0
	4	0
	3	Auto ICR Alarm (1: On, 0: Off)
	2	Auto ICR 1: On 0: Off
	1	0
0	Power 1: On 0: Off	
3	7	0
	6	0
	5	0
	4	ICR 1: On 0: Off
	3	Freeze 1: On 0: Off
	2	LR Reverse 1: On 0: Off
	1	0
0	0	
4	7	0
	6	0
	5	Privacy Zone 1: On 0: Off
	4	Mute 1: On 0: Off
	3	Title Display 1: On 0: Off
	2	Display 1: On 0: Off
	1	0
	0	0
5	7	0
	6	0
	5	0
	4	0
	3	Picture Effect Mode
	2	
1		
0		

Byte	Bit	Comments
6	7	0
	6	0
	5	0
	4	0
	3	0
	2	0
	1	0
	0	0
7	7	0
	6	0
	5	0
	4	0
	3	0
	2	0
	1	0
	0	0
8	7	0
	6	0
	5	0
	4	0
	3	Camera ID (HH)
	2	
	1	
	0	
9	7	0
	6	0
	5	0
	4	0
	3	Camera ID (HL)
	2	
	1	
	0	
10	7	0
	6	0
	5	0
	4	0
	3	Camera ID (LH)
	2	
	1	
	0	
11	7	0
	6	0
	5	0
	4	0
	3	Camera ID (LL)
	2	
1		
0		

Byte	Bit	Comments
12	7	0
	6	0
	5	0
	4	Memory 1: Provided 0: Not provided
	3	0
	2	ICR 1: Provided 0: Not provided
	1	Stabilizer 1:provided, 0: not provided
	0	1: 1/50, 1/25 0: 1/60, 1/30
13	7	0
	6	0
	5	0
	4	0
	3	Day&Night Mode ⁽³⁾
	2	0:auto
	1	1:day 2:night
	0	3:Ext-H, 4:Ext-L
14	7	0
	6	0
	5	0
	4	0
	3	0
	2	0
	1	0
	0	0
15	7	1 Terminator (FFh)
	6	1
	5	1
	4	1
	3	1
	2	1
	1	1
	0	1

Enlargement Function1 Query Command..... Command Packet 8x 09 7E 7E 03 FF

Byte	Bit	Comments
0	7	Destination Address
	6	
	5	
	4	
	3	Source Address
	2	
1		
1	0	0 Completion Message
	7	1
	6	0
	5	1
	4	0
	3	0
	2	0
	1	0
2	0	0
	7	0
	6	0
	5	0
	4	0
	3	Digital Zoom Position (H)
2		
1		
3	0	0
	7	0
	6	0
	5	0
	4	0
4	0	0
	7	0
	6	0
	5	0
	4	0
5	0	0
	7	0
	6	0
	5	0
	4	0
6	0	AF Activation Time (H)
	7	
	6	
	5	
	4	
7	0	AF Activation Time (L)
	7	
	6	
	5	
	4	
8	0	AF Interval Time (H)
	7	
	6	
	5	
	4	
9	0	AF Interval Time (L)
	7	
	6	
	5	
	4	
10	0	0
	7	0
	6	0
	5	0
	4	0
11	0	0
	7	0
	6	0
	5	0
	4	0
12	0	0
	7	0
	6	0
	5	0
	4	0
13	0	0
	7	0
	6	0
	5	0
	4	0
14	0	0
	7	0
	6	0
	5	0
	4	0
15	0	0
	7	0
	6	0
	5	0
	4	0

Byte	Bit	Comments
6	0	0
	7	0
	6	0
	5	0
	4	0
7	0	0
	7	0
	6	0
	5	0
	4	0
8	0	0
	7	0
	6	0
	5	0
	4	0
9	0	0
	7	0
	6	0
	5	0
	4	0
10	0	0
	7	0
	6	0
	5	0
	4	0
11	0	0
	7	0
	6	0
	5	0
	4	0
12	0	0
	7	0
	6	0
	5	0
	4	0
13	0	0
	7	0
	6	0
	5	0
	4	0
14	0	0
	7	0
	6	0
	5	0
	4	0
15	0	0
	7	0
	6	0
	5	0
	4	0
16	0	0
	7	0
	6	0
	5	0
	4	0
17	0	0
	7	0
	6	0
	5	0
	4	0
18	0	0
	7	0
	6	0
	5	0
	4	0
19	0	0
	7	0
	6	0
	5	0
	4	0
20	0	0
	7	0
	6	0
	5	0
	4	0
21	0	0
	7	0
	6	0
	5	0
	4	0
22	0	0
	7	0
	6	0
	5	0
	4	0
23	0	0
	7	0
	6	0
	5	0
	4	0
24	0	0
	7	0
	6	0
	5	0
	4	0
25	0	0
	7	0
	6	0
	5	0
	4	0
26	0	0
	7	0
	6	0
	5	0
	4	0
27	0	0
	7	0
	6	0
	5	0
	4	0
28	0	0
	7	0
	6	0
	5	0
	4	0
29	0	0
	7	0
	6	0
	5	0
	4	0
30	0	0
	7	0
	6	0
	5	0
	4	0
31	0	0
	7	0
	6	0
	5	0
	4	0
32	0	0
	7	0
	6	0
	5	0
	4	0
33	0	0
	7	0
	6	0
	5	0
	4	0
34	0	0
	7	0
	6	0
	5	0
	4	0
35	0	0
	7	0
	6	0
	5	0
	4	0
36	0	0
	7	0
	6	0
	5	0
	4	0
37	0	0
	7	0
	6	0
	5	0
	4	0
38	0	0
	7	0
	6	0
	5	0
	4	0
39	0	0
	7	0
	6	0
	5	0
	4	0
40	0	0
	7	0
	6	0
	5	0
	4	0
41	0	0
	7	0
	6	0
	5	0
	4	0
42	0	0
	7	0
	6	0
	5	0
	4	0
43	0	0
	7	0
	6	0
	5	0
	4	0
44	0	0
	7	0
	6	0
	5	0
	4	0
45	0	0
	7	0
	6	0
	5	0
	4	0
46	0	0
	7	0
	6	0
	5	0
	4	0
47	0	0
	7	0
	6	0
	5	0
	4	0
48	0	0
	7	0
	6	0
	5	0
	4	0
49	0	0
	7	0
	6	0
	5	0
	4	0
50	0	0
	7	0
	6	0
	5	0
	4	0
51	0	0
	7	0
	6	0
	5	0
	4	0
52	0	0
	7	0
	6	0
	5	0
	4	0
53	0	0
	7	0
	6	0
	5	0
	4	0
54	0	0
	7	0
	6	0
	5	0
	4	0
55	0	0
	7	0
	6	0
	5	0
	4	0
56	0	0
	7	0
	6	0
	5	0
	4	0
57	0	0
	7	0
	6	0
	5	0
	4	0
58	0	0
	7	0
	6	0
	5	0
	4	0
59	0	0
	7	0
	6	0
	5	0
	4	0
60	0	0
	7	0
	6	0
	5	0
	4	0
61	0	0
	7	0
	6	0
	5	0
	4	0
62	0	0
	7	0
	6	0
	5	0
	4	0
63	0	0
	7	0
	6	0
	5	0
	4	0
64	0	0
	7	0
	6	0
	5	0
	4	0
65	0	0
	7	0
	6	0
	5	0
	4	0
66	0	0
	7	0
	6	0
	5	0
	4	0
67	0	0
	7	0
	6	0
	5	0
	4	0
68	0	0
	7	0
	6	0
	5	0
	4	0
69	0	0
	7	0
	6	0
	5	0
	4	0
70	0	0
	7	0
	6	0
	5	0
	4	0
71	0	0
	7	0
	6	0
	5	0
	4	0
72	0	0
	7	0
	6	0
	5	0
	4	0
73	0	0
	7	0
	6	0
	5	0
	4	0
74	0	0
	7	0
	6	0
	5	0
	4	0
75	0	0
	7	0
	6	0
	5	0
	4	0
76	0	0
	7	0
	6	0
	5	0
	4	0
77	0	0
	7	0
	6	0
	5	0
	4	0
78	0	0
	7	0
	6	0
	5	0
	4	0
79	0	0
	7	0
	6	0
	5	0
	4	0
80	0	0
	7	0
	6	0
	5	0
	4	0
81	0	0
	7	0
	6	0
	5	0
	4	0
82	0	0
	7	0
	6	0
	5	0
	4	0
83	0	0
	7	0
	6	0
	5	0
	4	0
84	0	0
	7	0
	6	0
	5	0
	4	0
85	0	0
	7	0
	6	0
	5	0
	4	0
86	0	0
	7	0
	6	0
	5	0
	4	0
87	0	0
	7	0
	6	0
	5	0
	4	0
88	0	0
	7	0
	6	0
	5	0
	4	0
89	0	0
	7	0
	6	0
	5	0
	4	0
90	0	0
	7	0
	6	0
	5	0
	4	0
91	0	0
	7	0
	6	0
	5	0
	4	0
92	0	0
	7	0
	6	0
	5	0
	4	0
93	0	0
	7	0
	6	0
	5	0
	4	0
94	0	0
	7	0
	6	

Enlargement Function2 Query Command..... Command Packet 8x 09 7E 7E 04 FF

Byte	Bit	Comm
0	7	Destination Address
	6	
	5	
	4	
	3	Source Address
	2	
	1	
	0	
1	7	
	6	1
	5	0
	4	1
	3	0
	2	0
	1	0
	0	0
2	7	0
	6	0
	5	0
	4	0
	3	0
	2	WideD mode (0: OFF, 1: ON)
1		
0		
3	7	0
	6	0
	5	0
	4	0
	3	0
	2	0
	1	0
	0	0
4	7	0
	6	0
	5	0
	4	0
	3	0
	2	0
	1	WideD blown-out highlight correction level 0: L 1: M 2: H
	0	
5	7	0
	6	0
	5	0
	4	0
	3	0
	2	
0		

Byte	Bit	Comments
6	7	0
	6	0
	5	0
	4	0
	3	0
	2	
	1	
	0	
0		
7	7	0
	6	0
	5	0
	4	0
	3	0
	2	0
	1	0
	0	Defog Mode(1:on,0:off)
8	7	0
	6	0
	5	0
	4	0
	3	0
	2	0
	1	0
	0	0
9	7	0
	6	0
	5	0
	4	0
	3	0
	2	0
	1	0
	0	0
10	7	0
	6	0
	5	0
	4	0
	3	0
	2	0
	1	0
	0	0

Byte	Bit	Comments
11	7	0
	6	0
	5	0
	4	0
	3	0
	2	0
	1	0
	0	0
12	7	0
	6	0
	5	0
	4	0
	3	0
	2	0
	1	0
	0	0
13	7	0
	6	0
	5	0
	4	0
	3	0
	2	0
	1	0
	0	0
14	7	0
	6	0
	5	0
	4	0
	3	0
	2	0
	1	0
	0	0
15	7	1 Terminator (FFh)
	6	1
	5	1
	4	1
	3	1
	2	1
	1	1
	0	1

Enlargement Function3 Query Command..... Command Packet 8x 09 7E 7E 05 FF

Byte	Bit	Comments
0	7	Destination Address
	6	
	5	
	4	
	3	Source Address
	2	
	1	
	0	
1	7	
	6	1
	5	0
	4	1
	3	0
	2	0
	1	0
	0	0
2	7	0
	6	0
	5	0
	4	0
	3	0
	2	
	1	
	0	
3	7	
	6	Reserved
	5	
	4	
	3	
	2	
	1	
	0	
4	7	0
	6	Reserved
	5	
	4	
	3	
	2	
	1	
	0	
5	7	0
	6	Reserved
	5	
	4	
	3	
	2	
	1	
	0	

Byte	Bit	Comment
6	7	0
	6	Reserved
	5	
	4	
	3	
	2	
	1	
	0	
7	7	0
	6	Reserved
	5	
	4	
	3	
	2	
	1	
	0	
8	7	0
	6	Reserved
	5	
	4	
	3	
	2	
	1	
	0	
9	7	0
	6	Reserved
	5	
	4	
	3	
	2	
	1	
	0	
10	7	0
	6	Reserved
	5	
	4	
	3	
	2	
	1	
	0	

Byte	Bit	Comments
11	7	0
	6	Reserved
	5	
	4	
	3	
	2	
	1	
	0	
12	7	0
	6	Reserved
	5	
	4	
	3	
	2	
	1	
	0	
13	7	0
	6	Reserved
	5	
	4	
	3	
	2	
	1	
	0	
14	7	0
	6	Reserved
	5	
	4	
	3	
	2	
	1	
	0	
15	7	1 Terminator (FFh)
	6	1
	5	1
	4	1
	3	1
	2	1
	1	1
	0	1

Command Setting Values

SHUTTER SPEED

Index	60/30 mode	50/25 mode
16	1/30000	1/30000
15	1/10000	1/10000
14	1/6000	1/6000
13	1/4000	1/3500
12	1/3000	1/2500
11	1/2000	1/1750
10	1/1500	1/1250
0F	1/1000	1/1000
0E	1/725	1/600
0D	1/500	1/425
0C	1/350	1/300
0B	1/250	1/215
0A	1/180	1/150
09	1/125	1/120
08	1/100	1/100
07	1/90	1/75
06	1/60	1/50
05	1/30	1/25
04	1/15	1/12
03	1/8	1/6
02	1/4	1/3
01	1/2	1/2
00	1/1	1/1

IRIS

Index	Iris
11	F1.6
10	F2
0F	F2.4
0E	F2.8
0D	F3.4
0C	F3.8
0B	F4.2
0A	F4.8
09	F5.4
08	F6
07	F6.8
06	F8
05	F9.6
04	F11
03	F14
02	F16
01	F19
00	CLOSE

GAIN LIMIT & GAIN POSITION

Index	Gain
09	+36dB
08	+32dB
07	+28dB
06	+24dB
05	+20dB
04	+16dB
03	+12dB
02	+8dB
01	+4dB
00	+0dB (OFF)

EXPOSURE COMPENSTAIION(bright)

Index	Iris	Gain
0E	+7	+10.5 dB
0D	+6	+9 dB
0C	+5	+7.5 dB
0B	+4	+6 dB
0A	+3	+4.5 dB
09	+2	+3 dB
08	+1	+1.5 dB
07	0	0 dB
06	-1	-1.5 dB
05	-2	-3 dB
04	-3	-4.5 dB
03	-4	-6 dB
02	-5	-7.5 dB
01	-6	-9 dB
00	-7	-10.5 dB

Aperture (=sharpness)

Index	Level
0F	Sharp
...	
00	Dull

Red/Blue Manual Gain 0x00 ~ 0xFF

AE BRIGHT MODE LEVEL

Index	Iris	Gain
1F	F1.6	+58dB
1E	F1.6	+52dB
1D	F1.6	+48dB
1C	F1.6	+44dB
1B	F1.6	+40dB
1A	F1.6	+36dB
19	F1.6	+32dB
18	F1.6	+28dB
17	F1.6	+24dB
16	F1.6	+20dB
15	F1.6	+16dB
14	F1.6	+12dB
13	F1.6	+8dB
12	F1.6	+4dB
11	F1.6	0 dB
10	F2	0 dB
0F	F2.4	0 dB
0E	F2.8	0 dB
0D	F3.4	0 dB
0C	F3.8	0 dB
0B	F4.2	0 dB
0A	F4.8	0 dB
09	F5.4	0 dB
08	F6	0 dB
07	F6.8	0 dB
06	F8	0 dB
05~01	F9.6~F11	0 dB
00	CLOSE	0 dB

IRIS CLOSE LIMIT

Index	Open Level
A0	More Open
...	
60	default
...	
10	More Close

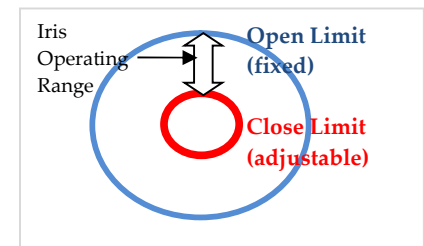

Title Setting

Line number	00 to 14h	
H-position	00 to 28h	
Blink	00: Dose not blink	
	01: Blinks	
Color	00	White
	01	Yellow
	02	Violet
	03	Red
	04~06	White

00	01	02	03	04	05	06	07
A	B	C	D	E	F	G	H
08	09	0a	0b	0c	0d	0e	0f
I	J	K	L	M	N	O	P
10	11	12	13	14	15	16	17
Q	R	S	T	U	V	W	X
18	19	1a	1b	1c	1d	1e	1f
Y	Z	&		?	!	1	2
20	21	22	23	24	25	26	27
3	4	5	6	7	8	9	0
28	29	2a	2b	2c	2d	2e	2f
À	È	Ì	Ò	Ù	Á	É	Í
30	31	32	33	34	35	36	37
Ó	Ú	Â	Ê	Ô	Æ		Ä
38	39	3a	3b	3c	3d	3e	3f
Õ	Ñ	Ç	ß	Ä	Ï	Ö	Ü
40	41	42	43	44	45	46	47
Å	\$		¥		£	¢	ı
48	49	4a	4b	4c	4d	4e	4f
ø	“	:	’	.	’	/	-
50							
→							

Custom/Memory Preset Setting Items

Item	Custom Preset	Memory Preset
Zoom Position	O	O
Digital Zoom On/Off	O	O
Digital Zoom Position	O	X
Zoom Start Position	O	X
Zoom Stop Position	O	X
Zoom Speed	O	X
AF Home Position	O	X
AF Limited Range	O	X
Focus Position	O	O
Focus Mode	O	O
Near Limit Setting	O	X
AF Sensitivity	O	X
AF Mode	O	O
AF Run Time	O	X
AF Interval Time	O	X

WB Mode	O	O
WB Data(Rgain,Bgain)	O	O
COLOR Gain	O	X
AE Mode	O	O
AE Response	O	X
AE Slow Shutter	O	O
Shutter Position	O	O
Iris Position	O	O
Gain Position	O	O
Gain Limit	O	O
Bright Position	O	O
Exposure Compensation Mode	O	O
Exposure Compensation Amount	O	O
Flickerless	O	X
Aperture Level	O	O
Gamma	O	X
High Resolution	O	X
LR Reverse	O	X
Picture Flip	O	X
Freeze	O	X
Picture Effect	O	X
D-WDR	O	X
Defog	O	O
Defog Level	O	X
3DNR Mode	O	O
3DNR Level	O	X
2DNR Mode	O	X
2DNR Weight	O	X
Digital Image Stabilizer On/Off	O	X
Digital Image Stabilizer Setting	O	X
BackLight On/Off	O	O
BLC Setting	O	X
WDR On/Off	O	O
HLC On/off	O	X
HLC Setting	O	X
ICR On/Off	O	O
Auto ICR On/Off	O	O
Day&Night Dwell Time	O	X
Day->Night AGC level	O	X
Night->Day AGC level	O	X
Day->Night EXT-H level	X	X
Night -> Day EXT-H level	X	X
Day->Night EXT-L level	X	X
Night -> Day EXT-L level	X	X
Privacy Mask On/Off	O	X
Privacy Mask Display	O	X
Privacy Mask Setting	O	X
Motion On/Off	O	X
Motion Display	O	X
Motion Setting	O	X
Title Display On/Off	O	X
Title Setting	O	X
Display On/Off	O	X
ETC	X	X

Register Setting

CAM_RegisterValue	8x 01 04 24 mm 0p 0p FF	mm: Register No. (=00-7F) pp: Register Value (=00-7F)
-------------------	----------------------------	--

command	Register (mm)	Value (pp)	contents
VISCA Baud Rate	00	00 (Default)	9600 bps
		01	19200 bps
		02	38400 bps
		03	115200bps
		04	57600 bps
		05	2400 bps
		06	4800 bps
Monitoring Mode	72	01	1080i/60 ^(*)
		02	1080i/60 ^(*)
		04	1080i/50 ^(*)
		06	1080p/30
		07	1080p/30 ^(*)
		08	1080p/25
		09	720p/60
		0A	720p/60 ^(*)
		0C	720p/50
		0E	720p/30
		0F	720p/30 ^(*)
		11	720p/25
		13	1080p/60
		14	1080p/50
		15	1080p/60 ^(*)
LVDS mode	74	00 (Default)	Single output
		01	Dual output
Zoom Limit	50	00-FF (default:00)	Wide Limit
	51	00-FF (default:00)	Tele Limit
E-Zoom Max	52	00-FF (Default:EB)	Max. digital zoom ratio = 256 ÷ (256-Value)
FocusOffset @DomeCover	55	00-FF (Default:00)	00: None FF: Max.
Auto Slow shutter limit ^(*)	56	01 (default)	1/30
		02	1/15
		03	1/8
		04	1/4
		05	1/2
		06	1/1
Enlargement Mode ^(*)	5F	00-FF (default:00)	Bit3:Auto ICR OFF→ON setting enable ON/OFF (1:ON, 0:OFF)

Language ^(*)	60	00-06	00:English 01:Russian 02:Spanish 03:Chinese 04:German 05:Franch 06:Portuguese 07:Japanes
CVBS scale ^(*)	7C	00 01	4:3 16:9
EX-SDI V1.0 ^(*)	7E	00 01	OFF ON
E-Zoom Speed (V2.1.0)	3D	00~FF (default:00)	00:slow FF:fast
DVR-Select (=color type) (V2.1.0)	4D	00~XX	pp : DVR See. DVR select

GAMMA POSITION

Index	Gamma
0	0.45
1	0.50
2	0.55
3	0.60

PELCO-D protocol for RS-485/RS-232

Command	Output : PELCO-D	Description
Zoom +	FF 01 00 20 00 00 CS	
Zoom -	FF 01 00 40 00 00 CS	
Focus +	FF 01 01 00 00 00 CS	
Focus -	FF 01 00 80 00 00 CS	
Iris +	FF 01 02 00 00 00 CS	It is used for Menu
Iris -	FF 01 04 00 00 00 CS	
Stop	FF 01 00 00 00 00 CS	
Go To Preset	FF 01 00 07 00 zz CS	zz : preset no (00~FF) total 256 zoom/focus position presets. Reserved presets : zz = 21, 5F, 60,62
Set Preset	FF 01 00 03 00 zz CS	
Clear Preset	FF 01 00 05 00 zz CS	
Flip(180 rotate)	FF 01 00 07 00 21 CS	
Menu or SET	FF 01 00 07 00 5F CS	Menu command(Go to preset + 95)
Menu or SET	FF 01 00 07 00 60 CS	Menu command(Go to preset + 96)
Menu or SET	FF 01 00 03 00 62 CS	Menu command(Set preset + 98)
Zoom speed	FF 01 00 25 00 zz CS	zz = 00(slow)-03 (fast), default:02
Reset camera to default	FF 01 00 29 00 00 CS	Initialize camera settings
Auto focus auto/on/off	FF 01 00 2B 00 zz CS	zz = 00(auto),01(one push AF),02(one push mode), 03(manual)
Backlight on/off	FF 01 00 31 00 zz CS	zz = 01(on),02(off)
Auto white balance on/off	FF 01 00 33 00 zz CS	zz = 01(Auto WB mode),02(manual WB mode)
Set Shutter speed	FF 01 00 37 zz zz CS	zzzz : shutter speed (see. Shutter speed table)

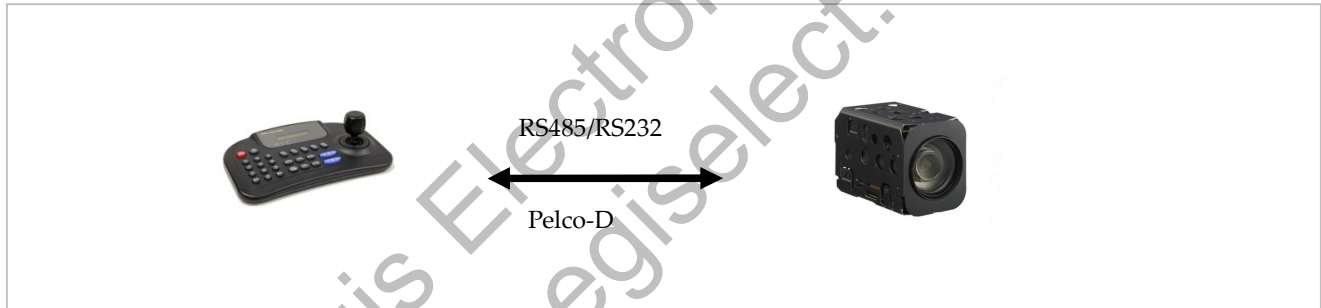

Supported DVRs

Video Output – Standard Device (HD-AVI, HD-TVI, HD-SDI, EX-SDI(V1.0))