



xix-Xtreme

[ksi-x-treme:] or [sai-ex:tri:m]

- Fast PCIe cameras with Sony Pregius S sensors

XIMEA Cameras •
Technical Manual •
Version v250512 •

Introduction

About this manual

Dear customer,

Thank you for purchasing a product from XIMEA.

We hope that this manual can answer your questions, but should you have any further queries or if you wish to claim a service or warranty case, please contact your local dealer or refer to XIMEA Support on our website: www.ximea.com/support

The purpose of this document is to provide a description of XIMEA Cameras and to describe the correct way to install related software, drivers and run it successfully. Please read this manual thoroughly before operating your new XIMEA Cameras for the first time. Please follow all instructions and observe the warnings.

This document is subject to change without notice.

About XIMEA

XIMEA is one of the worldwide leaders for innovative camera solutions with a 30-year history of research, development and production of digital image acquisition systems. Based in Slovakia, Germany and the US, with a global distributor network, XIMEA offers their cameras worldwide. In close collaboration with customers XIMEA has developed a broad spectrum of technologies and cutting-edge, highly competitive products.

XIMEA's camera centric technology portfolio comprises a broad spectrum of digital technologies, from data interfaces such as USB 2.0, USB 3.1 and PCIe to cooled digital cameras with CCD, CMOS and sCMOS sensors, as well as X-ray cameras.

XIMEA has three divisions – generic machine vision and integrated vision systems, scientific imaging and OEM/custom.

Our broad portfolio of cameras includes thermally stabilized astronomy and x-ray cameras, as well as specialty cameras for medical applications, research, surveillance and defense.

Contact XIMEA

XIMEA is a worldwide operating company

Headquarters, Sales worldwide

XIMEA GmbH
Am Mittelhafen 16
48155 Münster
Germany

Tel: +49 (251) 202 408-0
Fax: +49 (251) 202 408-99

Web www.ximea.com
General inquiries info@ximea.com
Sales sales@ximea.com
Support XIMEA Support

Sales America

XIMEA Corp.
12600 W Colfax Ave., Suite A-130
Lakewood, CO 80215
USA

Tel: +1 (303) 389-9838
Fax: +1 (303) 202-6350

R&D, Production

XIMEA s.r.o.
Lesná 52
900 33 Marianka
Slovakia

Tel: +421 (2) 205 104 26
Fax: +421 (2) 205 104 27

Standard conformity

CE conformity



Figure 1: Standard conformity CE logo

The camera models listed below, equipped with the SFF-8644 adapter (XIMEA P-N: ADPT-MX-X4G3-FF-X4G3-SFF), comply with the EC EMC Directive 2014/30/EU requirements for electromagnetic compatibility.

The measurements and testing were conducted using a 5-meter PCIe SFF-8644 copper cable and a 10-meter SFF-8644 fiber optic cable.

Certified camera models include

all models in this manual (refer to the table [Models and sensors overview](#))

UKCA conformity



Figure 2: Standard conformity UKCA logo

We declare that the products listed below comply with the requirements of Directive 2014/35/EU (Low Voltage Directive) and Directive 2014/30/EU (Electromagnetic Compatibility).

All tests are based on EU rules and standards valid before January 1, 2021 (Brexit). The harmonized EU product standards were converted into UK designated standards on exit day. Based on that, these products are UKCA compliant.

Certified camera models include

all models in this manual (refer to the table [Models and sensors overview](#))

FCC conformity



Figure 3: Standard conformity FCC logo

The camera models listed below have been tested and found to comply with Part 15 of the FCC rules, which states that:

Operation is subject to the following two conditions:

1. This device may not cause harmful interference.
2. This device must accept any interference received, including interference that may cause undesired operation.

This equipment has been tested and found to comply with the limits for a Class A digital device, pursuant to Part 15 of the FCC rules. These limits are designed to provide reasonable protection against harmful interference when the equipment is operated in a commercial environment. This equipment generates, uses, and can radiate radio frequency energy and, if not installed and used in accordance with the instruction manual, may cause harmful interference to radio communications. Operation of this equipment in a residential area is likely to cause harmful interference, in which case the users will be required to correct the interference at their own expense.

You are cautioned that any changes or modifications not expressly approved in this manual could void your authority to operate this equipment under the above jurisdictions. The shielded interface cable recommended in this manual must be used with this equipment to comply with the limits for a computing device pursuant to Subpart J of Part 15 of FCC Rules.

Certified camera models include
all models in this manual (refer to the table [Models and sensors overview](#))

RoHS conformity



Figure 4: Standard conformity RoHS logo

The products described in this technical manual comply with the RoHS-3 (Restriction of Hazardous Substances) Directive 2015/863/EU.

WEEE conformity

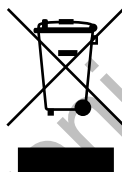

Figure 5: Standard conformity WEEE logo

The products described in this technical manual comply with the WEEE (Waste Electrical and Electronic Equipment) Directive 2012/19/EU.

GenICam GenTL API



The [GenICam/GenTL](#) standard offers a device-agnostic interface for the acquisition of images and other data types, as well as for communication with devices. This enables each XIMEA camera to function as a GenTL Producer, facilitating the capture of images through a standardized transport layer interface.

Disclaimer

This document and the technical data contained herein are for descriptive purposes only and not binding. They are not to be construed as warranted characteristics or guarantees of properties, quality or durability in the legal sense. Specifications are subject to change without notice. The information contained in this document is provided “as is” without warranty of any kind.

Helpful links

XIMEA Homepage	http://www.ximea.com/
XIMEA Support	https://www.ximea.com/support/wiki/allprod/Contact_Support
Frequently Asked Questions	http://www.ximea.com/support/wiki/allprod/Frequently_Asked_Questions
Knowledge Base	http://www.ximea.com/support/wiki/allprod/Knowledge_Base
XIMEA Software Package	https://www.ximea.com/support/wiki/apis/APIs#Software-packages
Vision Libraries	http://www.ximea.com/support/projects/vision-libraries/wiki
XIMEA General Terms & Conditions	http://www.ximea.com/en/corporate/generaltc

Aegis Electronic Group
www.aegiselect.com

Contents

About this manual	2
About XIMEA	2
Contact XIMEA	2
Standard conformity	3
Helpful links	5
1 xiX-Xtreme camera series	8
1.1 What is xiX-Xtreme	8
1.2 Advantages	8
1.3 Camera applications	9
1.4 Common features	9
1.5 Model nomenclature	10
1.6 Models and sensors overview	11
1.7 Accessories overview	12
2 Hardware specification	13
2.1 Power supply	13
2.2 General specification	14
2.2.1 Environment	14
2.3 Lens mount	15
2.3.1 C-mount	15
2.4 Mounting points	16
2.4.1 Screws	16
2.5 Optical path	17
2.6 Sensor and camera characteristics	20
2.6.1 Sensor and camera parameters	20
2.6.2 Image quality parameters	21
2.6.3 Sensor read-out modes	23
2.6.4 Quantum efficiency curves	26
2.7 Mechanical characteristics	28
2.7.1 Dimensions and mass	28
2.7.2 Dimensional drawings	29
2.8 User interface – LEDs	31
2.9 Camera interface	32
2.9.1 PCIe / FireFly interface	32
2.10 Digital inputs / outputs (GPIO) interface	35
2.10.1 Optically isolated Digital Input (IN)	37
2.10.2 Optically isolated Digital Output (OUT)	38
2.10.3 Non-isolated digital lines - Digital Input-Output (INOUT)	39
2.11 Accessories	40
2.11.1 CBL-PB4-PWR-0M15	40
2.11.2 CBL-PB6-PT-0M30	40
2.11.3 CBL-ECUE-X4G3-1M0/2M0/3M0	40
2.11.4 CBL-HQCD-0M15	41
2.11.5 CB-X8G3-FAN-COOLER	42
2.11.6 CB-X8G3-WAT-COOLER-KIT	43
2.11.7 MECH-60MM-BRACKET-T	45
2.11.8 MQ-BRACKET-T	46
2.11.9 ADPT-MX-X4G3-FF-X4G3-MTP	47
2.11.10 CBL-MT-PWR-SYNC-3M0	50
2.11.11 ADPT-MX-X4G3-FF-X4G3-SFF	51
2.11.12 FireFly MTP adapters	54
2.11.13 PCIe host adapters	56
3 General features	58
3.1 Camera features	58
3.1.1 ROIs – Region of interest	58
3.1.2 Downsampling modes	58

3.1.3	Image data output formats	59
3.2	Acquisition modes	61
3.2.1	Free-Run	61
3.2.2	Trigger controlled acquisition/exposure	61
3.3	Exposure time	64
3.4	Gain	64
3.5	Dual ADC modes	65
3.5.1	Combined mode	66
3.5.2	Non-combined mode	67
3.6	API Features	68
3.6.1	Exposure – Auto gain	68
3.6.2	White balance	68
3.6.3	Gamma	68
3.6.4	Sharpness	68
3.6.5	Color correction matrix	68
3.6.6	Sensor defect correction	68
3.6.7	Flat field correction	68
4	Operation	73
4.1	System requirements	73
4.1.1	Software requirements	73
4.1.2	Hardware requirements	73
4.2	XIMEA software packages	74
4.2.1	XIMEA Windows software package	74
4.2.2	XIMEA Linux software package	77
4.2.3	XIMEA macOS software package	79
4.3	XIMEA CamTool	82
4.4	XIMEA control panel	83
4.5	Supported vision libraries	84
4.5.1	MathWorks MATLAB	84
4.5.2	MVTec HALCON	84
4.5.3	National Instruments LabVIEW vision library	84
4.5.4	OpenCV	84
4.6	Programming	85
4.6.1	Standard interface	85
4.6.2	xiAPI	85
5	Appendix	89
5.1	Troubleshooting and support	89
5.1.1	Worldwide support	89
5.1.2	Before contacting technical support	89
5.2	Frequently Asked Questions	89
5.3	Product service request (PSR)	90
5.4	Safety instructions and precautions	91
5.5	Warranty	91
5.6	Standard Terms & Conditions of XIMEA GmbH	91
5.7	List of Trademarks	91
5.8	Copyright	91
	Glossary	92
	List of figures	93
	List of tables	95

1 xiX-Xtreme camera series

1.1 What is xiX-Xtreme

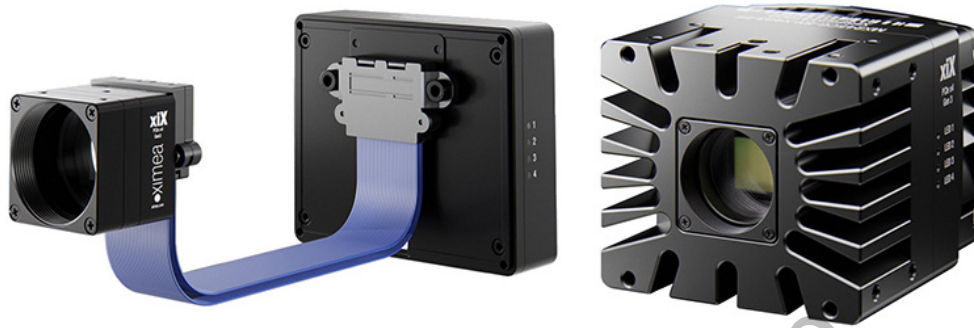

xiX-Xtreme is the high-speed PCI express camera family with detachable sensor heads:

- Sony Pregius S sensors with 16.1 Mpx, 20.3 Mpx, and 24.5 Mpx
- Super-fast 32 Gbit/s data throughput to ensure 105 fps 24.5 Mpx up to 159 fps 16.1 Mpx enabled by PCIe X4G3
- The detachable sensor heads measure only 26 × 26 × 33 mm
 - Sensor module is separable from camera electronics over distances up to 1 m
- Special sensor features like Dual ADC (HDR mode), short shutter interval time, and others

The xiX-Xtreme cameras offer the opportunity to reach the full sensor specifications while still keeping the smallest possible form factor. Our innovative approach separates the sensor head from the readout electronics, facilitating integration into the most confined spaces. This separation not only optimizes spatial utility but also drastically reduces heat accumulation at the sensor, lowering noise levels and enhancing image quality. The pixel size of 2.74 μm helps to use C-mount lenses thus further improving the cost-effectivity and enabling miniature size for mobile and multiple camera systems.

1.2 Advantages

- Lightweight** facilitates increased performance of robotic arms and gimbals or UAV / UAS
- Efficient** low power consumption and heat dissipation
- Robust** sturdy full metal jacket, no sheet metal covers
- Adaptable** customization options via Board level or connectors allow easy integration into OEM solutions
- Economical** removes bulky constructions and accessories saving energy and space at better prices
- Simplistic** straightforward way for easy multiple camera system, no workarounds, no frame grabbers

1.3 Camera applications

- automation
- ultra-fast 3D scanning
- miniature and fast robotic arms
- mobile devices
- in-situ optical inspection camera
- material and life science microscopy
- ophthalmology and retinal imaging
- broadcasting
- fast process capture, e.g. golf club swings
- Intelligent Transportations Systems (ITS) and traffic monitoring
- VR and AR
- cinematography
- sports
- unmanned vehicles
- UAV / drones etc

1.4 Common features

Acquisition modes	global shutter
Image data formats	8 bit, 10 bit, 12 bit RAW pixel data
Sensor technology	CMOS
Sensor versions	backside illuminated (BSI)
Partial image readout	ROI, Skipping and Binning modes supported (model specific)
Interface	PCI Express standard cable connector compliant to PCI Express external cabling specifications
Color image processing	Host based de-bayering, sharpening, Gamma, color matrix, true color CMS
Hot/blemish pixels correction	on camera storage of up to 5000 px coordinates, host assisted correction
Auto adjustments	auto white balance, auto gain, auto exposure
Flat field corrections	host assisted pixel level shading and lens corrections - this feature is being developed and tested
General purpose I/O	I/O 1x opto-isolated input, 1x opto-isolated output, and 4x non-isolated bidirectional I/O, 4x user configurable LEDs
Synchronization	hardware trigger input, software trigger, exposure strobe output, busy output
Housing and lens mount Standard	C-mount
Environment	operating 0 to 50 °C on housing, RH 80 % non-condensing, -25 to 60 °C storage
Operating systems	Windows, Linux Ubuntu, macOS
Software support	xiAPI SDK, adapters and drivers for various image processing libraries
Firmware updates	field firmware update through xiCOP tool

1.5 Model nomenclature

xi-Xtreme MXxxxT-zz-X4G3-FF

MX xiX family name

xxx: resolution in 0.1 MPixel. E.g. 2.3 MPixel Resolution: xxx = 023

y: Color sensing

C: color model

M: black & white model

T: Sensor technology

G: Global shutter

zz: Vendor of the sensor

SY: Sony

X4G3: Number of PCIe lanes used, 4 for these cameras
PCIe generation, currently at Gen 3 for these cameras

FF: FireFly cable connection

Aegis Electronic Group
www.aegiselect.com

1.6 Models and sensors overview

Camera model	Sensor model	Sensor type	Filter	Resolution [px]	Pixel size [μm]
MX161CG-SY-X4G3-FF	Sony IMX532	Color	BayerBG	5328 × 3040	2.74
MX161MG-SY-X4G3-FF	Sony IMX532	Monochrome	None	5328 × 3040	2.74
MX203CG-SY-X4G3-FF	Sony IMX531	Color	BayerBG	4512 × 4512	2.74
MX203MG-SY-X4G3-FF	Sony IMX531	Monochrome	None	4512 × 4512	2.74
MX245CG-SY-X4G3-FF	Sony IMX530	Color	BayerBG	5328 × 4608	2.74
MX245MG-SY-X4G3-FF	Sony IMX530	Monochrome	None	5328 × 4608	2.74

Table 1: List of camera models and their respective sensor models and filters

Aegis Electronic Group
www.aegiselect.com

1.7 Accessories overview

The following accessories are available:

Item P/N	Description
CBL-PB4-PWR-0M15	Power cable with barrel connector 15 cm long
CBL-PB6-PT-0M30	IO pig tail cable 30 cm long
CBL-ECUE-X4G3-0M30	Cable Micro Assembly, Low-Profile FireFly, 30 cm
CBL-ECUE-X4G3-1M0	Cable Micro Assembly, Low-Profile FireFly, 100 cm
CBL-ECUE-X4G3-2M0	Cable Micro Assembly, Low-Profile FireFly, 200 cm
HA-1/2P-X4G3-MTP/FF-X8G3	Ximea PCIe Dual FireFly x4 Gen 3 Host Adapter Card
ADPT-1/2/4P-X4G3-FF-X4/8G3-MTP	PCIe Adapter FireFly to MTP
ADPT-MX-X4G3-FF-X4G3-MTP	MTP Adaptor for MX-X4G3-FF camera
CB-X8G3-FAN-COOLER-KIT	Heatsink Fan Cooler for X8G3 cameras with screws Kit
CB-X8G3-WAT-COOLER-KIT	Heatsink Water Cooler for X8G3 cameras with screws Kit
CBL-HQCD-0M15	Highspeed Coaxial HQCD cable, 15 cm length
CBL-HQCD-0M50	Highspeed Coaxial HQCD cable, 50 cm length
CBL-HQCD-1M0	Highspeed Coaxial HQCD cable, 100 cm length
MECH-60MM-BRACKET-T-KIT	MECH Tripod Bracket 60 mm with Screws Kit
MQ-BRACKET-T-KIT	MQ series tripod mounting bracket TYP B with Screws Kit ¹

¹In case of only small sensor board housing.

Table 2: Accessories overview

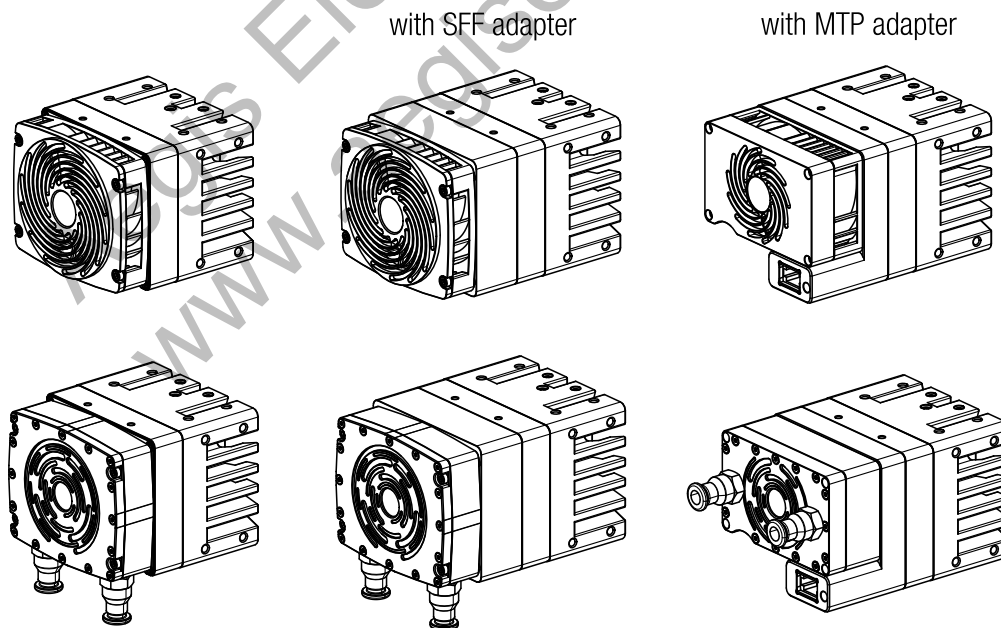

Figure 6: Camera with accessory/cooling options

2 Hardware specification

2.1 Power supply

The power consumption table can consist of several values:

- Supply voltage:** Voltage used for measuring the power consumption.
- Idle:** The average power consumption when the camera is powered, but not opened/initialized in software.
- Typical:** The average power consumption during streaming in the most power-intensive mode, (typically the one with the highest frame rate).
- Maximum:** The highest power consumption peak recorded during streaming in the most power-intensive mode, (measured using a current probe).

Power consumption of:
all models in this manual (refer to the table [Models and sensors overview](#))

Supply Voltage ¹	Consumption idle	Consumption typical	Consumption maximum
12 V	9.65 W	14.3 W	14.6 W

¹Supported voltage 12 - 24 V

Table 3: Power consumption of the specific models

Aegis Electronic Group
www.aegiselect.com

2.2 General specification

2.2.1 Environment

Description	Symbol	Value
Optimal ambient temperature operation	T_{opt}	10 to 25 °C
Ambient temperature operation	T_{max}	0 to 50 °C
Ambient temperature for storage and transportation	$T_{storage}$	-25 to 60 °C
Relative Humidity, non-condensing	RH	80 %

Table 4: Environment

Housing temperature must not exceed 65 °C.

Note: The following parameters are not guaranteed if the cameras are operated outside the optimum range:

- Dark current
- Dynamic Range
- Linearity
- Acquisition
- Readout noise
- S/N ratio
- Durability

Aegis Electronic Group
www.aegiselect.com

2.3 Lens mount

2.3.1 C-mount

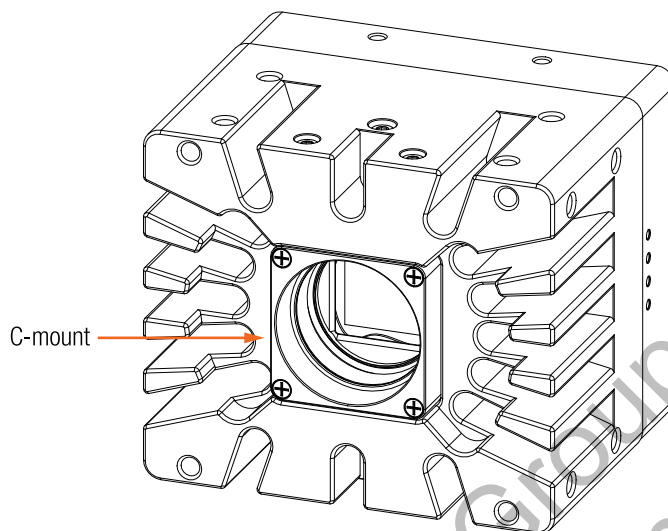

Figure 7: Lens mount adapter C-mount for xiX-Xtreme camera models

The maximum difference between the flange focal distance and back focal distance for C-mount lenses must not exceed 6 mm. Otherwise, there is a risk of damaging the protective glass inside the camera or limiting the capability to focus to infinity.

The mentioned lens adapter is included in:
all models in this manual (refer to the table [Models and sensors overview](#))

Aegis Electronic Group
www.aegiselect.com

2.4 Mounting points

The mounting points available to the customer are shown below. Use only the designated threaded holes for mounting the camera. Utilize only the specified screws and torques when fastening.

Specific mounting information can be found in the dimensional drawings of the camera models located in section [Dimensional drawings](#).

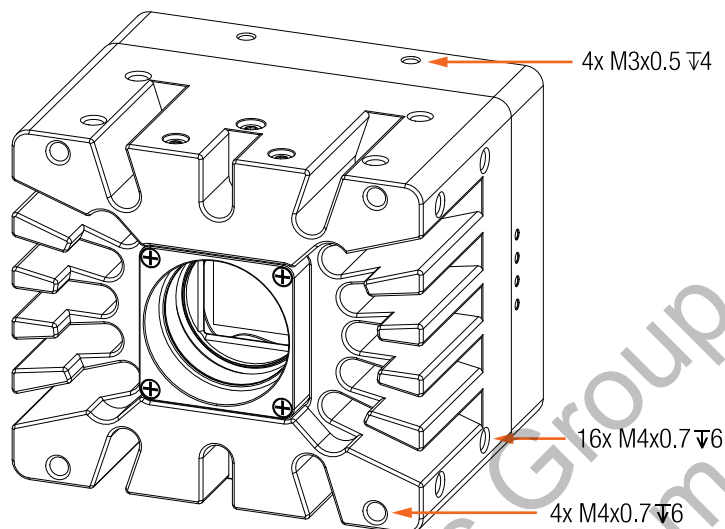

Figure 8: xiX-Xtreme camera mounting points

2.4.1 Screws

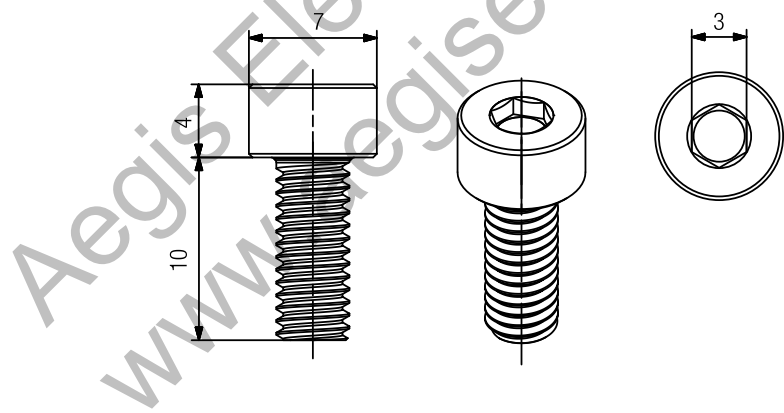

Figure 9: M4 mounting screws

Item	Value
Material	Stainless steel
Surface	Polished
Thread	M4 Full thread
Driver	INBUS 3.0
Avail. lengths	6 to 40 mm

Table 5: M4 screw description

2.5 Optical path

The optical path in cameras defines the course traversed by light from the observed object to the image captured by the sensor. It involves complex interactions with components (e.g. lenses).

The flange focal distance (FFD) or optical distance is the distance between a lens's mounting flange and a camera's sensor plane. In standard setups, it assumes that only air fills the space between the lens and the sensor. However, the introduction of additional elements like windows or filters can alter the focal plane through refraction, requiring an adjusted FFD for proper alignment.

The presence or absence of a filter or sensor window in the camera depends on the camera model. The distance from the flange to the sensor is designed (refer to the camera cross-section image below for visual information).

Do not use compressed air to clean the camera as this could push dust particles into the camera or potentially cause damage (e.g. scratches).

Cross-section corresponding to:
all models in this manual (refer to the table [Models and sensors overview](#))

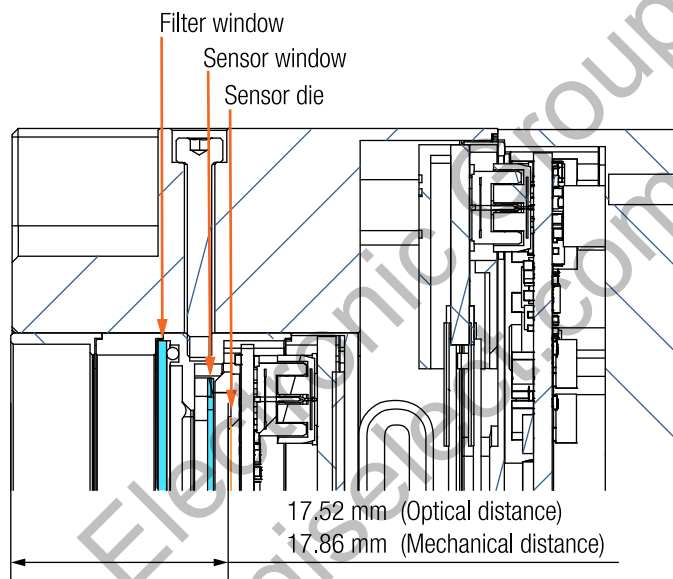

Figure 10: Cross section of MX161/203/245xG-SY-X4G3-FF camera models

The following filter window is implemented in:

MX161CG-SY-X4G3-FF

MX203CG-SY-X4G3-FF

MX245CG-SY-X4G3-FF

Filter	Coating	Thickness
IR Filter IR650	ARx2	1.1 mm

Table 6: IR650 filter window parameter

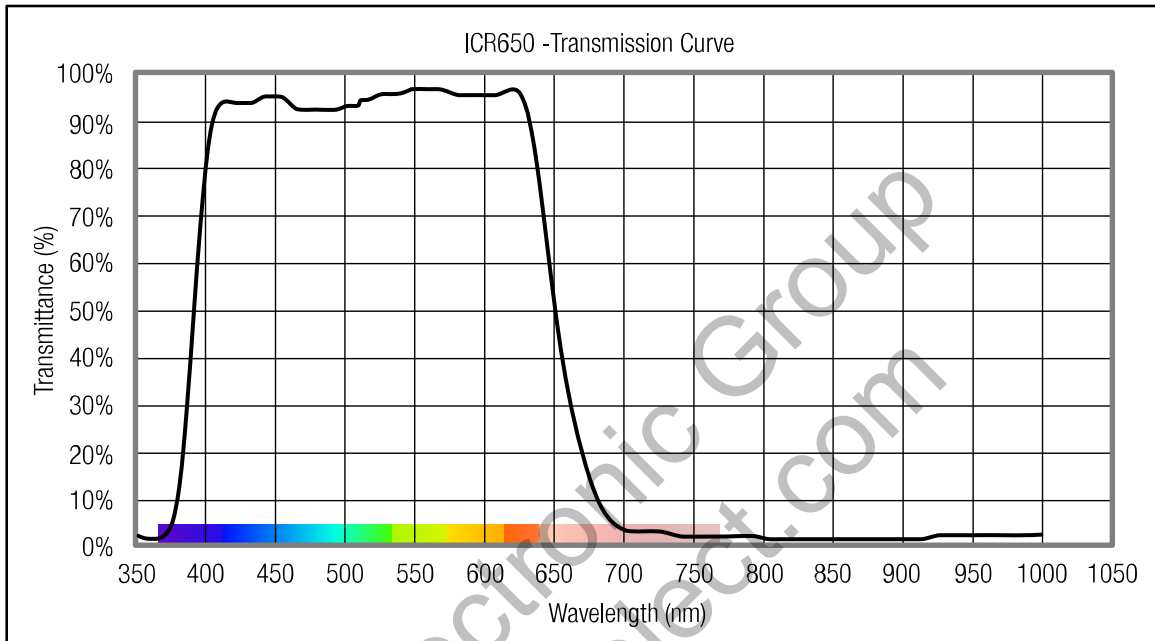

Figure 11: Filter glass ICR650 Transmission Curve

The following filter window is implemented in:

MX161MG-SY-X4G3-FF

MX203MG-SY-X4G3-FF

MX245MG-SY-X4G3-FF

Filter	Coating	Thickness
Filter BK7	ARx2	1.1 mm

Table 7: BK7 filter window parameter

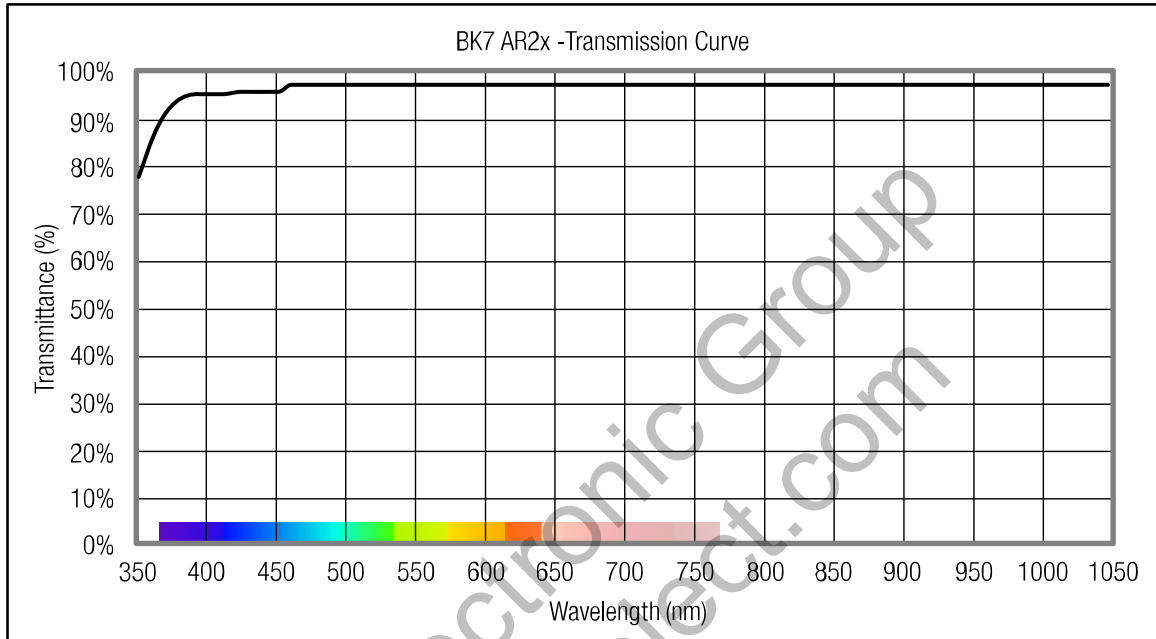

Figure 12: Filter glass BK7 AR2x Transmission Curve

2.6 Sensor and camera characteristics

2.6.1 Sensor and camera parameters

Sensor parameters of:
MX161CG-SY-X4G3-FF

MX161MG-SY-X4G3-FF

Description	Value	Unit
Technology	CMOS	None
Pixel resolution (H x V)	5328 x 3040	[px]
Active area size (H X V)	14.58 x 8.31	[mm]
Sensor diagonal	16.8	[mm]
Pixel size (H x V)	2.74 x 2.74	[μ m]

Table 8: Sensor parameters of the specific models

Sensor parameters of:
MX203CG-SY-X4G3-FF

MX203MG-SY-X4G3-FF

Description	Value	Unit
Technology	CMOS	None
Pixel resolution (H x V)	4512 x 4512	[px]
Active area size (H X V)	12.34 x 12.34	[mm]
Sensor diagonal	17.5	[mm]
Pixel size (H x V)	2.74 x 2.74	[μ m]

Table 9: Sensor parameters of the specific models

Sensor parameters of:
MX245CG-SY-X4G3-FF

MX245MG-SY-X4G3-FF

Description	Value	Unit
Technology	CMOS	None
Pixel resolution (H x V)	5328 x 4608	[px]
Active area size (H X V)	14.58 x 12.6	[mm]
Sensor diagonal	19.3	[mm]
Pixel size (H x V)	2.74 x 2.74	[μ m]

Table 10: Sensor parameters of the specific models

2.6.2 Image quality parameters

The image quality parameters listed below represent typical values for these camera models. Minor variations may occur between different units of the same model.

Image quality parameters of:
MX161CG-SY-X4G3-FF

MX161MG-SY-X4G3-FF

Mode		8 bit	10 bit	12 bit	Dual ADC 8 bit	Dual ADC 10 bit	Dual ADC 12 bit
Sensor bit/px	[bit/px]	8	10	12	8	10	12
Parameters	None	None	None	None	None	None	None
Median read noise	[e.]	4.55	4.61	2.21	1.3	1.92	1.6
Saturation capacity	[ke.]	2.37	9.56	9.28	2.34	9.88	9.35
Dynamic range	[dB]	53.37	65.38	70.58	61.13	71.85	72.65
MAX Signal-to-noise ratio	[dB]	33.75	39.81	39.68	33.69	39.95	39.71
Conversion gain	[e./LSB]	0.62	2.52	2.38	0.04	0.16	0.15
Dark current	[e./s]	2.06	2.06	1.21	1.74	2.24	2.12
DSNU	[e.]	0.52	0.52	0.45	0.4	0.54	0.6
PRNU	[%]	0.7	0.64	0.66	0.64	0.63	0.65
Linearity error	[%]	0.68	0.43	0.54	0.72	0.44	0.88

Table 11: Image quality parameters of the specific models

Image quality parameters of:
MX203CG-SY-X4G3-FF

MX203MG-SY-X4G3-FF

Mode		8 bit	10 bit	12 bit	Dual ADC 8 bit	Dual ADC 10 bit	Dual ADC 12 bit
Sensor bit/px	[bit/px]	8	10	12	8	10	12
Parameters	None	None	None	None	None	None	None
Median read noise	[e.]	4.55	4.6	1.85	1.28	1.74	1.42
Saturation capacity	[ke.]	2.36	9.76	9.31	2.29	9.07	8.64
Dynamic range	[dB]	53.35	65.61	71.8	60.92	71.7	72.6
MAX Signal-to-noise ratio	[dB]	33.73	39.89	39.69	33.6	39.58	39.37
Conversion gain	[e./LSB]	0.62	2.51	2.4	0.14	0.14	0.14
Dark current	[e./s]	2.28	2.52	1.5	2.3	2.18	2.11
DSNU	[e.]	0.51	0.52	0.83	0.41	0.49	0.56
PRNU	[%]	0.88	0.78	0.81	0.77	0.77	0.79
Linearity error	[%]	0.31	0.26	0.64	0.7	0.45	0.97

Table 12: Image quality parameters of the specific models

Mode		8 bit	10 bit	12 bit	Dual ADC 8 bit	Dual ADC 10 bit	Dual ADC 12 bit
Sensor bit/px	[bit/px]	8	10	12	8	10	12
Parameters	None	None	None	None	None	None	None
Median read noise	[e.]	4.49	4.64	2.23	1.31	1.85	1.56
Saturation capacity	[ke.]	2.4	9.89	9.41	2.32	9.89	9.4
Dynamic range	[dB]	53.63	65.66	70.6	61.57	72.18	72.91
MAX Signal-to-noise ratio	[dB]	33.82	40.32	40.1	33.67	40.32	40.11
Conversion gain	[e./LSB]	0.61	2.51	2.4	0.04	0.16	0.15
Dark current	[e./s]	2.28	1.28	1.91	1.03	1.61	2.15
DSNU	[e.]	0.78	0.52	0.64	0.4	0.54	0.65
PRNU	[%]	0.86	0.81	0.81	0.83	0.8	0.81
Linearity error	[%]	0.74	0.46	1.02	0.89	0.48	0.97

Table 13: Image quality parameters of the specific models

Aegis Electronic Group
www.aegiselect.com

2.6.3 Sensor read-out modes

Sensor Read-out modes of:
MX161CG-SY-X4G3-FF

Downsampling (Hor.x Ver.)	Dual ADC	Sensor bit/px	Resolution (Wid x Hei)	Transport bit/px	Frame rate ¹
1 x 1	-	8	5328 x 3040	8	160.4
Dec.2 x 2	-	8	2656 x 1520	8	310.8
1 x 1	-	10	5328 x 3040	10	154.1
Dec.2 x 2	-	10	2656 x 1520	10	298.5
1 x 1	-	12	5328 x 3040	12	112.0
Dec.2 x 2	-	12	2656 x 1520	12	218.3
1 x 1	Combined	8	5328 x 3040	8	56.6
1 x 1	Combined	12	5328 x 3040	12	56.6
1 x 1	Non-Comb.	8	5328 x 3040	8	81.7
1 x 1	Non-Comb.	10	5328 x 3040	10	78.5
1 x 1	Non-Comb.	12	5328 x 3040	12	56.9

¹Frame rate was measured using the transport format at bandwidth limit 3500.0 MB/s

Table 14: Sensor read-out modes of the specific models

Sensor Read-out modes of:
MX161MG-SY-X4G3-FF

Downsampling (Hor.x Ver.)	Dual ADC	Sensor bit/px	Resolution (Wid x Hei)	Transport bit/px	Frame rate ¹
1 x 1	-	8	5328 x 3040	8	160.4
Dec.2 x 2	-	8	2656 x 1520	8	560.7
Bin.2 x 2	-	8	2656 x 1520	8	560.7
1 x 1	-	10	5328 x 3040	10	154.1
Dec.2 x 2	-	10	2656 x 1520	10	528.5
Bin.2 x 2	-	10	2656 x 1520	10	528.5
1 x 1	-	12	5328 x 3040	12	112.0
Dec.2 x 2	-	12	2656 x 1520	12	417.2
Bin.2 x 2	-	12	2656 x 1520	12	417.2
1 x 1	Combined	8	5328 x 3040	8	56.6
1 x 1	Combined	12	5328 x 3040	12	56.6
1 x 1	Non-Comb.	8	5328 x 3040	8	81.7
1 x 1	Non-Comb.	10	5328 x 3040	10	78.5
1 x 1	Non-Comb.	12	5328 x 3040	12	56.9

¹Frame rate was measured using the transport format at bandwidth limit 3500.0 MB/s

Table 15: Sensor read-out modes of the specific models

Sensor Read-out modes of:
MX203CG-SY-X4G3-FF

Downsampling (Hor.x Ver.)	Dual ADC	Sensor bit/px	Resolution (Wid x Hei)	Transport bit/px	Frame rate ¹
1 x 1	-	8	4512 x 4512	8	110.1
Dec.2 x 2	-	8	2256 x 2256	8	215.5
1 x 1	-	10	4512 x 4512	10	105.8
Dec.2 x 2	-	10	2256 x 2256	10	207.0
1 x 1	-	12	4512 x 4512	12	76.7
Dec.2 x 2	-	12	2256 x 2256	12	150.8
1 x 1	Combined	8	4512 x 4512	8	38.6
1 x 1	Combined	12	4512 x 4512	12	38.6
1 x 1	Non-Comb.	8	4512 x 4512	8	55.8
1 x 1	Non-Comb.	10	4512 x 4512	10	53.6
1 x 1	Non-Comb.	12	4512 x 4512	12	38.8

¹Frame rate was measured using the transport format at bandwidth limit 3500.0 MB/s

Table 16: Sensor read-out modes of the specific models

Sensor Read-out modes of:
MX203MG-SY-X4G3-FF

Downsampling (Hor.x Ver.)	Dual ADC	Sensor bit/px	Resolution (Wid x Hei)	Transport bit/px	Frame rate ¹
1 x 1	-	8	4512 x 4512	8	110.1
Dec.2 x 2	-	8	2256 x 2256	8	411.6
Bin.2 x 2	-	8	2256 x 2256	8	411.6
1 x 1	-	10	4512 x 4512	10	105.8
Dec.2 x 2	-	10	2256 x 2256	10	396.6
Bin.2 x 2	-	10	2256 x 2256	10	396.6
1 x 1	-	12	4512 x 4512	12	76.7
Dec.2 x 2	-	12	2256 x 2256	12	291.8
Bin.2 x 2	-	12	2256 x 2256	12	291.8
1 x 1	Combined	8	4512 x 4512	8	38.6
1 x 1	Combined	12	4512 x 4512	12	38.6
1 x 1	Non-Comb.	8	4512 x 4512	8	55.8
1 x 1	Non-Comb.	10	4512 x 4512	10	53.6
1 x 1	Non-Comb.	12	4512 x 4512	12	38.8

¹Frame rate was measured using the transport format at bandwidth limit 3500.0 MB/s

Table 17: Sensor read-out modes of the specific models

Sensor Read-out modes of:
MX245CG-SY-X4G3-FF

Downsampling (Hor.x Ver.)	Dual ADC	Sensor bit/px	Resolution (Wid x Hei)	Transport bit/px	Frame rate ¹
1 x 1	-	8	5328 x 4608	8	107.9
Dec.2 x 2	-	8	2664 x 2304	8	211.3
1 x 1	-	10	5328 x 4608	10	103.6
Dec.2 x 2	-	10	2664 x 2304	10	202.9
1 x 1	-	12	5328 x 4608	12	75.2
Dec.2 x 2	-	12	2664 x 2304	12	147.8
1 x 1	Combined	8	5328 x 4608	8	37.9
1 x 1	Combined	12	5328 x 4608	12	37.9
1 x 1	Non-Comb.	8	5328 x 4608	8	54.7
1 x 1	Non-Comb.	10	5328 x 4608	10	52.5
1 x 1	Non-Comb.	12	5328 x 4608	12	38.0

¹Frame rate was measured using the transport format at bandwidth limit 3500.0 MB/s

Table 18: Sensor read-out modes of the specific models

Sensor Read-out modes of:
MX245MG-SY-X4G3-FF

Downsampling (Hor.x Ver.)	Dual ADC	Sensor bit/px	Resolution (Wid x Hei)	Transport bit/px	Frame rate ¹
1 x 1	-	8	5328 x 4608	8	107.9
Dec.2 x 2	-	8	2664 x 2304	8	387.9
Bin.2 x 2	-	8	2664 x 2304	8	387.9
1 x 1	-	10	5328 x 4608	10	103.6
Dec.2 x 2	-	10	2664 x 2304	10	365.1
Bin.2 x 2	-	10	2664 x 2304	10	365.1
1 x 1	-	12	5328 x 4608	12	75.2
Dec.2 x 2	-	12	2664 x 2304	12	286.2
Bin.2 x 2	-	12	2664 x 2304	12	286.2
1 x 1	Combined	8	5328 x 4608	8	37.9
1 x 1	Combined	12	5328 x 4608	12	37.9
1 x 1	Non-Comb.	8	5328 x 4608	8	54.7
1 x 1	Non-Comb.	10	5328 x 4608	10	52.5
1 x 1	Non-Comb.	12	5328 x 4608	12	38.0

¹Frame rate was measured using the transport format at bandwidth limit 3500.0 MB/s

Table 19: Sensor read-out modes of the specific models

2.6.4 Quantum efficiency curves

Quantum efficiency curves for:
MX161CG-SY-X4G3-FF

MX161MG-SY-X4G3-FF

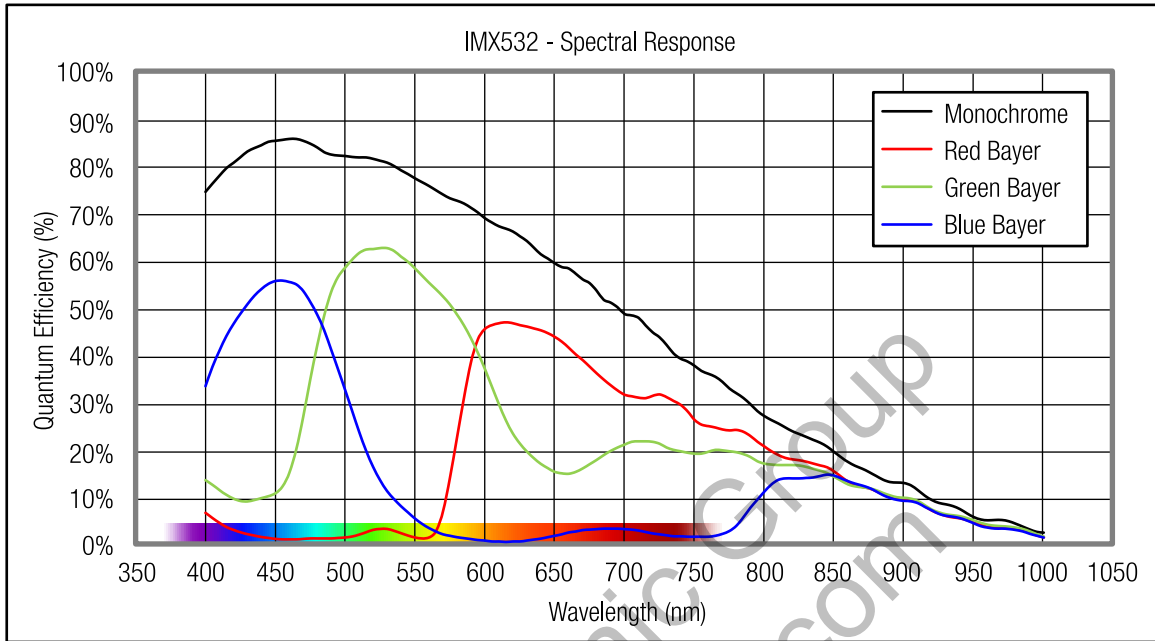

Figure 13: Graph quantum efficiency of Sony IMX532

Quantum efficiency curves for:
MX203CG-SY-X4G3-FF

MX203MG-SY-X4G3-FF

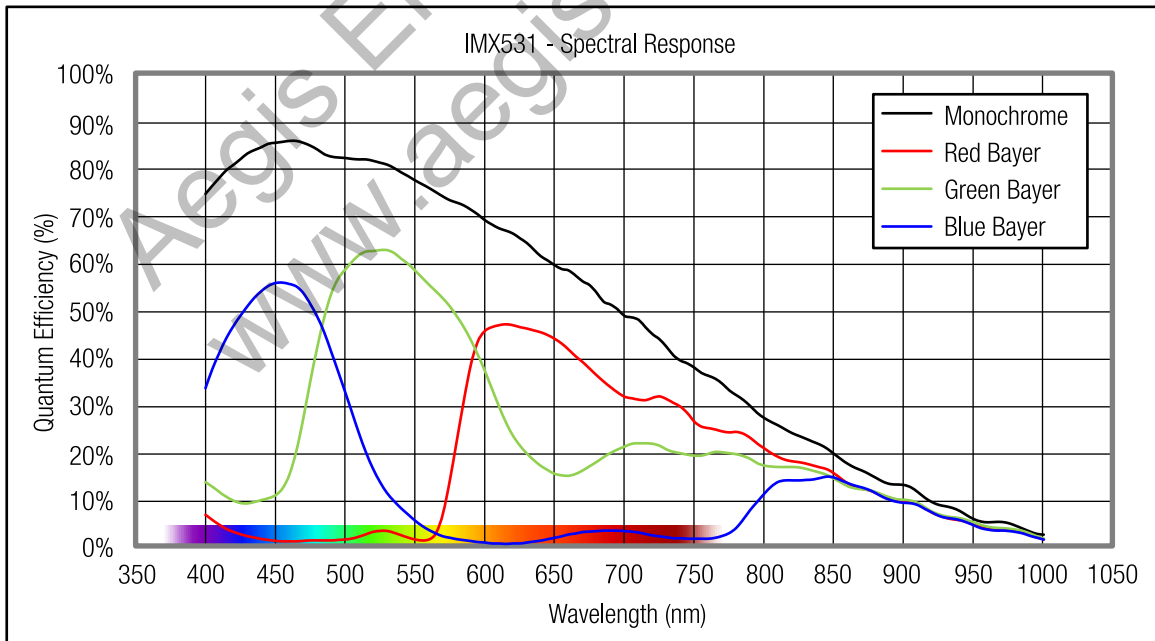

Figure 14: Graph quantum efficiency of Sony IMX531

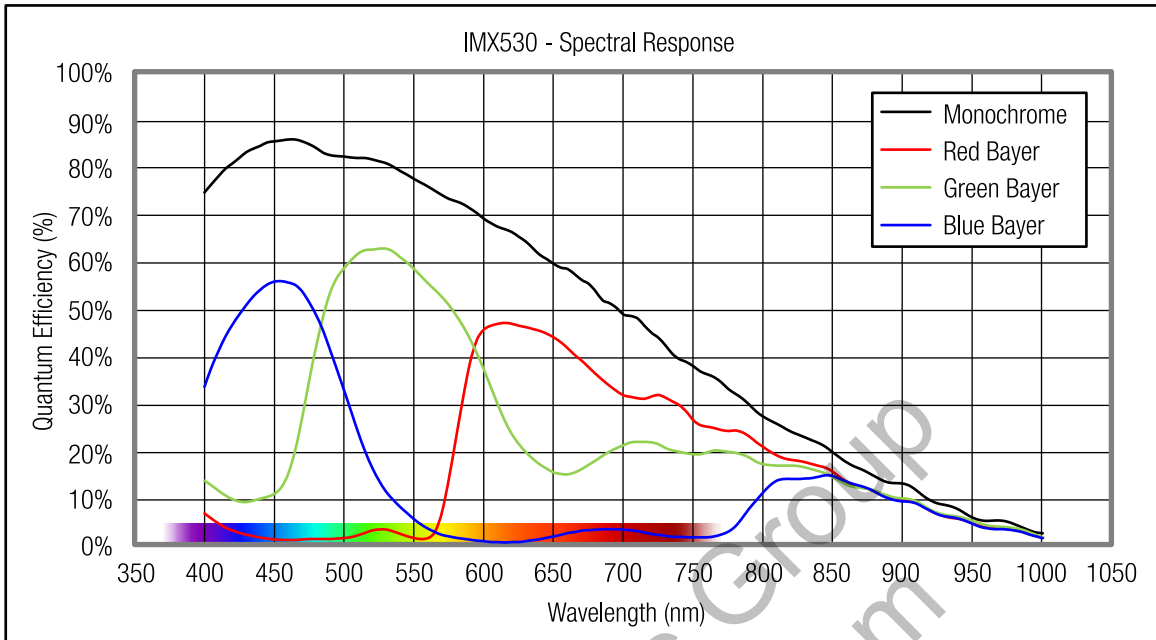

Figure 15: Graph quantum efficiency of Sony IMX530

Aegis Electronic Group
www.aegiselect.com

2.7 Mechanical characteristics

2.7.1 Dimensions and mass

Dimensions and mass of:
all models in this manual (refer to the table [Models and sensors overview](#))

Width [W]	Height [H]	Depth ¹ [D]	Mass ¹ [M]
70 mm	60 mm	55 mm	395 g

¹without adapters

Table 20: Camera parameters of the specific models

Aegis Electronic Group
www.aegiselect.com

2.7.2 Dimensional drawings

Dimensional drawings of:
all models in this manual (refer to the table [Models and sensors overview](#))

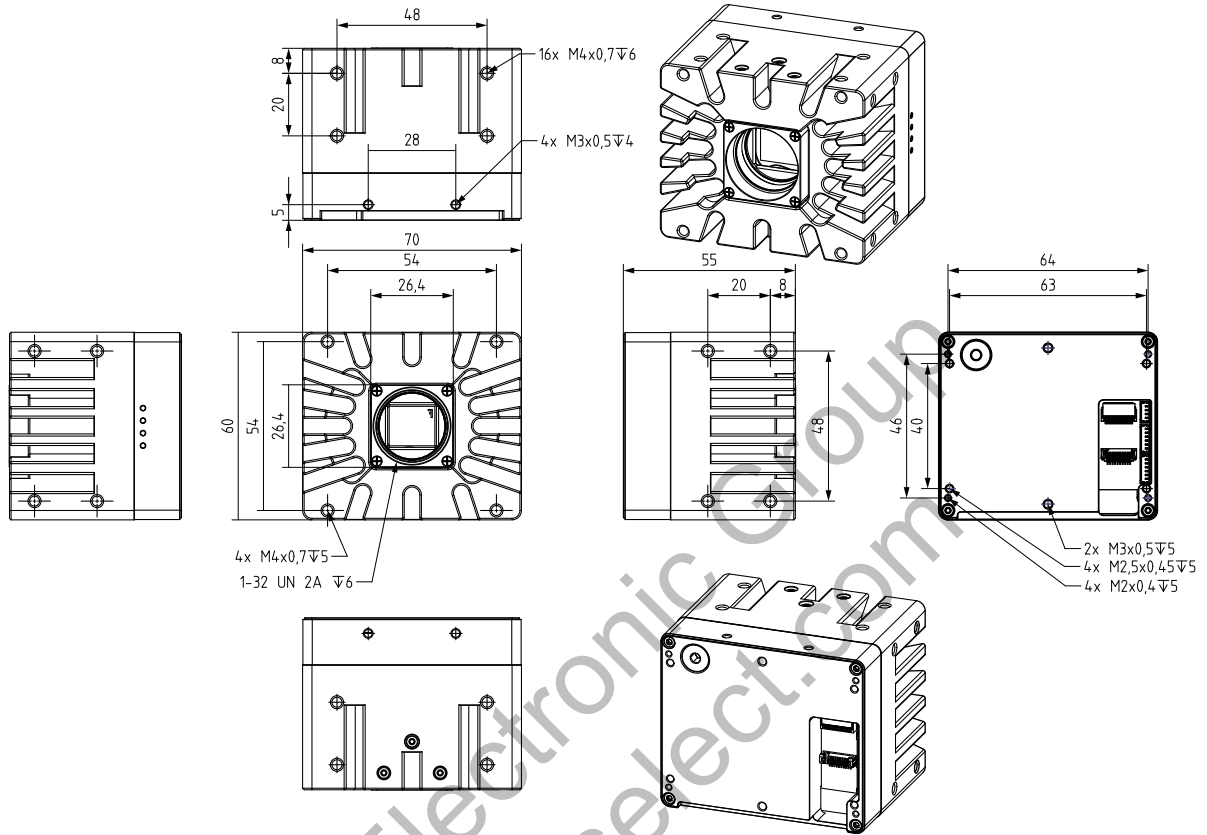

Figure 16: Dimensional drawing of MX161/203/245xR-SY-X4G3-xxx

Dimensional drawings of:
all models in this manual (refer to the table [Models and sensors overview](#))

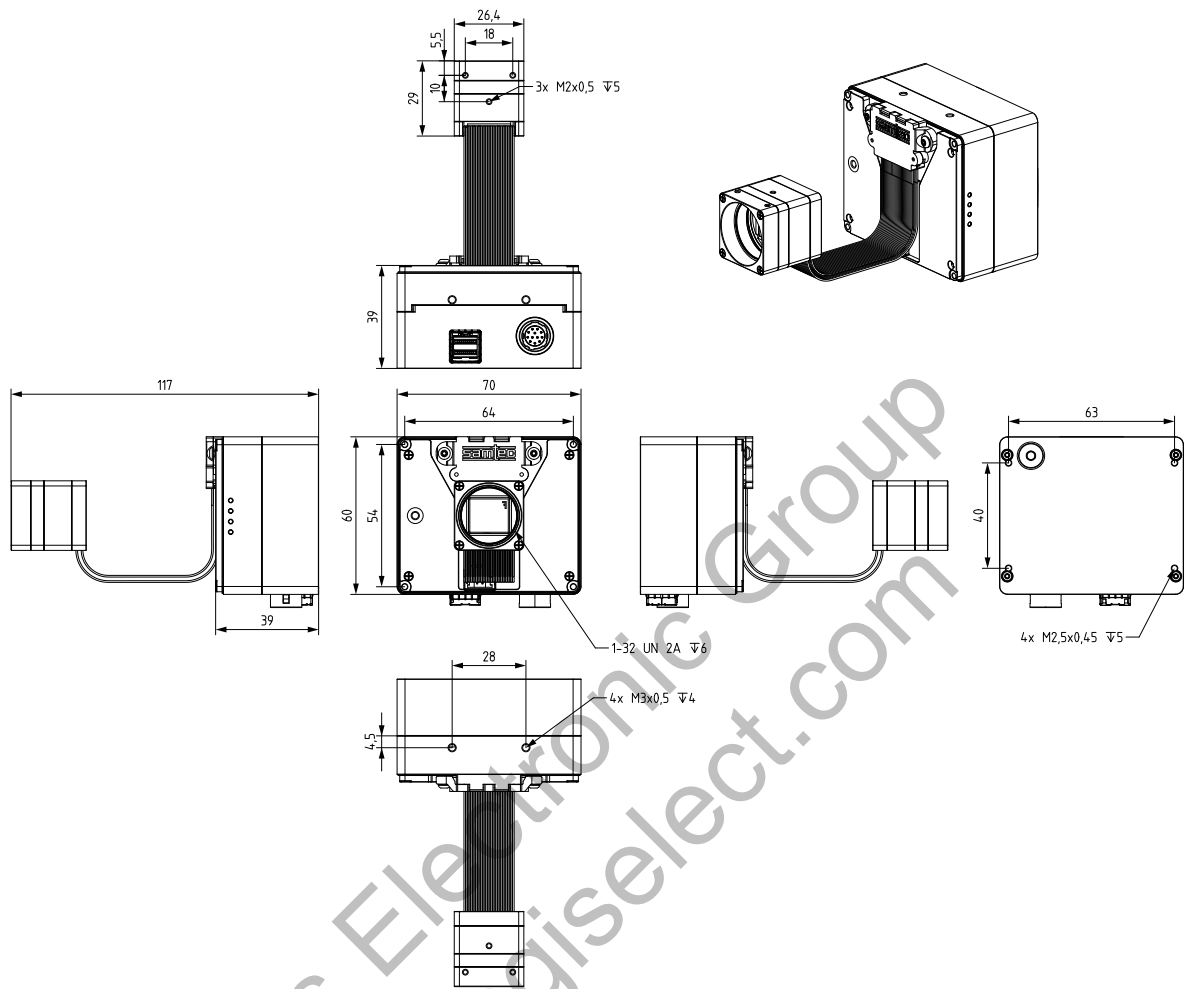

Figure 17: Dimensional drawing of MX161/203/245xR-SY-X4G3-xxx with detached sensor sub-assembly

2.8 User interface – LEDs

LED	Color	Defaults	Note
1	Green	PCIe Lanes	User configurable
2	Red	PCIe Clock Present	User configurable
3	Blue	PCIe Clock Present	User configurable
4	Orange	PCIe Link Speed	User configurable

Table 21: LED output description during camera power up

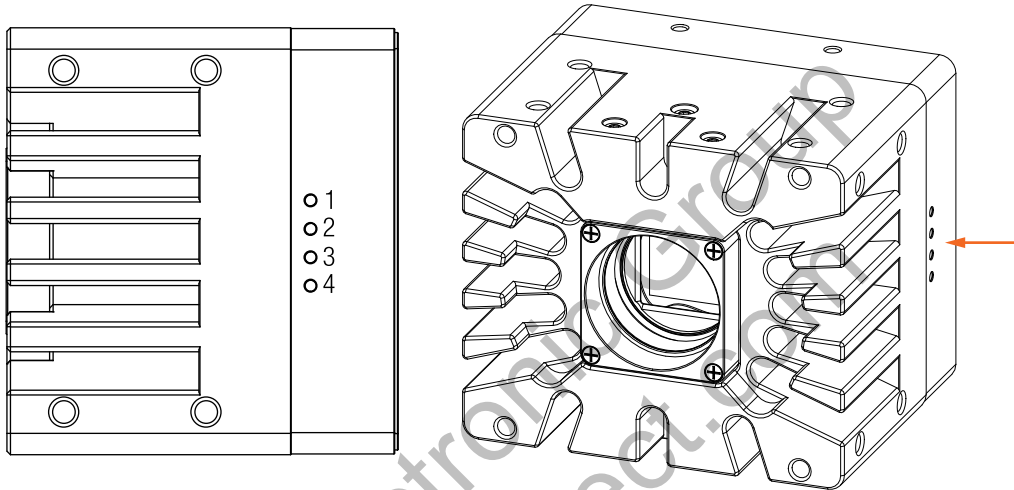

Figure 18: Position of LEDs on xiX-Xtreme camera

LED statuses during boot sequence of:
all models in this manual (refer to the table [Models and sensors overview](#))

Status	LED 1	LED 2	LED 3	LED 4
Off	Off	Off	Off	Off
Power	On	Off	Off	Off
Camera booted, no PCIe connection	Off	Off	On	On
Recovery firmware loaded ¹	flash	flash	flash	flash
PCIe connected X4 Gen3	On	flash	flash	On
PCIe connected (X2 or X1) Gen3	flash	flash	flash	On

¹To identify, if the recovery firmware is loaded, please start xiCOP. See [XIMEA control panel](#)

Table 22: LED statuses during boot sequence

2.9 Camera interface

NOTE: It is important that the power is turned off when inserting/detaching the cable. General ESD precautions need to be applied. Failing this requirement may lead to camera damage.

The following section applies to:
all models in this manual (refer to the table [Models and sensors overview](#))

2.9.1 PCIe / FireFly interface

The interface connector is used for data transmission, camera control, power and IO (see section [Digital inputs / outputs \(GPIO\) interface](#) for IO connector pinout description). To prevent camera damage, always ensure the power is turned off before inserting or detaching the cable. For cameras with the [ADPT-MX-X4G3-FF-X4G3-MTP](#) or [ADPT-MX-X4G3-FF-X4G3-SFF](#) adapter, refer to the appropriate adapter section.

Item	Value
Connector	Samtec (UEC5-019-1-H-D-RA-1-A + UCC8-010-1-H-S-1-A)
Signals	PCIe 4 Gen3; Power input; Optoisolated IO
Mating Connectors	Samtec ECUE, PCU0

Table 23: Firefly interface mating connector description

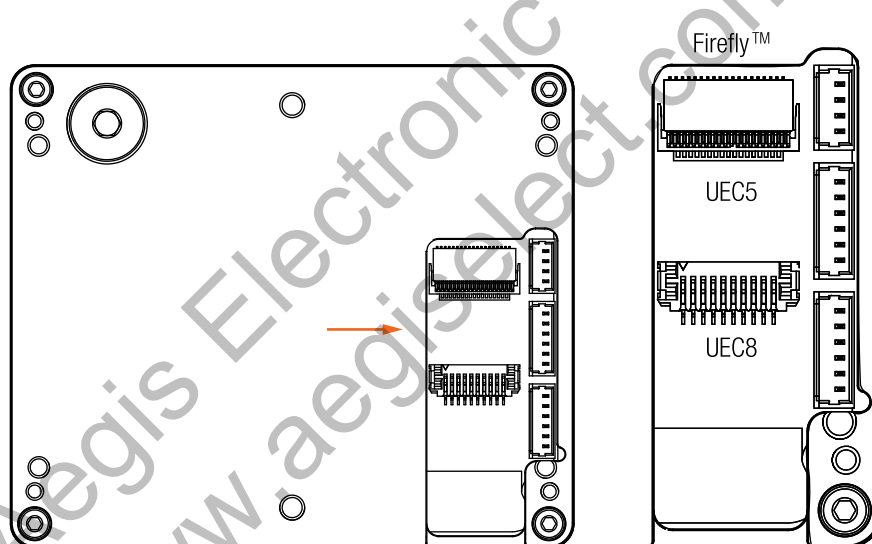

Figure 19: PCIe / FireFly connector location

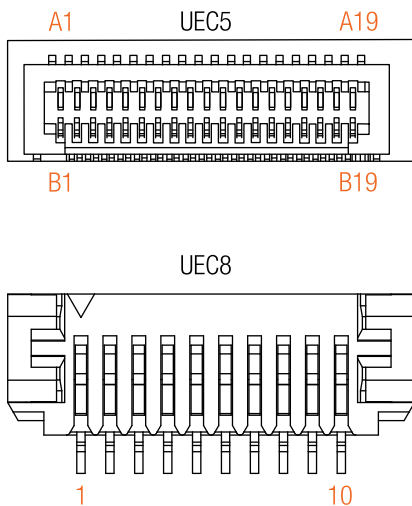

Figure 20: PCIe / FireFly connector pinout

Pin	Name	Type
1	VCC_TX	Power output
2	GND	Ground
3	NC	None
4	NC	None
5	PCIe_RST0_N_IN	PCIe reset
6	NC	None
7	NC	None
8	NC	None
9	OUT1	Optically isolated Digital Output (OUT)
10	VCC_RX	Power output

Table 24: FireFly UEC8 connector pin assignment

Pin	Name	Type	Pin	Name	Type
A1	GND	Signal and power ground	B1	GND	Signal and power ground
A2	PCle_PETN_2	PCle TX differential pair 2	B2	PCle_PETN_3	PCle TX differential pair 3
A3	PCle_PETP_2	PCle TX differential pair 2	B3	PCle_PETP_3	PCle TX differential pair 3
A4	GND	Signal	B4	GND	Signal and power ground
A5	PCle_PETN_1	PCle TX differential pair 1	B5	PCle_PETN_0	PCle TX differential pair 0
A6	PCle_PETP_1	PCle TX differential pair 1	B6	PCle_PETP_0	PCle TX differential pair 0
A7	GND	Signal and power ground	B7	GND	Signal and power ground
A8	IN1	Optically isolated Digital Input (IN)	B8	OUT1	Optically isolated Digital Output (OUT)
A9	IN1_GND	Ground for opto-isolated Input 1	B9	OUT1_GND	Ground for opto-isolated Output 1
A10	GND	Signal and power ground	B10	GND	Signal and power ground
A11	PCle_RST0_N_IN	PCle reset	B11	PWR	Power input
A12	NC	None	B12	PWR	Power input
A13	GND	Signal and power ground	B13	GND	Signal and power ground
A14	PCle_PERP_2	PCle RX differential pair 2	B14	PCle_PERN_3	PCle RX differential pair 3
A15	PCle_PERN_2	PCle RX differential pair 2	B15	PCle_PERP_3	PCle RX differential pair 3
A16	GND	Signal and power ground	B16	GND	Signal and power ground
A17	PCle_PERP_1	PCle RX differential pair 1	B17	PCle_PERN_0	PCle RX differential pair 0
A18	PCle_PERN_1	PCle RX differential pair 1	B18	PCle_PERP_0	PCle RX differential pair 0
A19	GND	Signal and power ground	B19	GND	Signal and power ground

Table 25: FireFly UEC5 connector pin assignment

2.10 Digital inputs / outputs (GPIO) interface

The description of the GPIO interface below applies to:
all models in this manual (refer to the table [Models and sensors overview](#))

Pin	Name	GPI/GPO index	API	Type
Pinout FireFly UCC8 connector				
9	OUT1	-/1		Optically isolated Digital Output (OUT)
Pinout FireFly UEC5 connector				
A8	IN1	1/-		Optically isolated Digital Input (IN)
B8	OUT1	-/1		Optically isolated Digital Output (OUT)

Table 26: Firefly connector I/O pin assignment

Connector	Signals	Mating Connectors
4 pin Pico Blade	AUX power input	Molex 0510210400
6 pin Pico Blade	Optically isolated IO	Molex 0510210600
6 pin Pico Blade	Non isolated IO	Molex 0510210600

Table 27: GPIO mating connector description

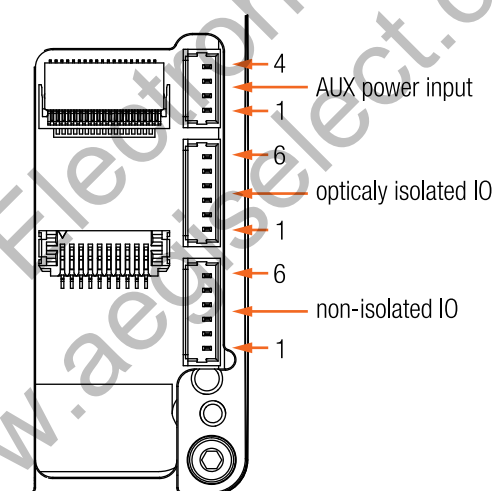

Figure 21: IO connectors position

Pin	Name	Type
AUX power input pin assignment		
1	GND	Power ground
2	PWR_IN	Power input
3	PWR_IN	Power input
4	GND	Power ground

Table 28: Power connector pin assignment

Pin	Name	GPI/GPO index API	Type
Optically isolated IO pin assignment			
1	IN1	1/-	Optically isolated Digital Input (IN)
2	IN_GND	None	Common pole for optically isolated inputs
3	IN2	2/-	Optically isolated Digital Input (IN)
4	OUT1	-/1	Optically isolated Digital Output (OUT)
5	OUT_GND	None	Common pole for optically isolated outputs
6	OUT2	-/2	Optically isolated Digital Output (OUT)
Non-isolated IO pin assignment			
1	INOUT1	3/3	Non-isolated digital lines - Digital Input-Output (INOUT)
2	GND	None	Common pole for non-isolated IO (same as power GND)
3	INOUT2	4/4	Non-isolated digital lines - Digital Input-Output (INOUT)
4	INOUT3	5/5	Non-isolated digital lines - Digital Input-Output (INOUT)
5	GND	None	Common pole for non-isolated IO (same as power GND)
6	INOUT4	6/6	Non-isolated digital lines - Digital Input-Output (INOUT)

Table 29: I/O connector pin assignment

Aegis Electronic Group
www.aegiselect.com

2.10.1 Optically isolated Digital Input (IN)

The description of optically isolated digital input below applies to:
all models in this manual (refer to the table [Models and sensors overview](#))

Item	Parameter	Note
Maximal input voltage	24 V DC	None
Common pole	YES	IN GND
Effect of incorrect input terminal connection	Reverse voltage polarity protected	None
Effects when withdrawing/inserting input module under power	no damage, no lost data	None
Maximal recommended cable length	10m	None
Input Level for logical 0	Voltage < 1.2 V / Current < 0.3 mA	None
Input Level for logical 1	Voltage > 3.3 V / Current > 1 mA	None
Input debounce filter	No	None
Input delay - rising edge	0.1 μ s	VINPUT=10 V,TAMBIENT=25 °C
Input delay - falling edge	5 μ s	VINPUT=10 V,TAMBIENT=25 °C
External trigger mapping	YES	None
Input functions	Trigger	Rising or falling edge are supported for trigger

Table 30: General info for optically isolated digital input

2.10.2 Optically isolated Digital Output (OUT)

The description of optically isolated digital output below applies to: all models in this manual (refer to the table [Models and sensors overview](#))

Item	Parameter	Note
Maximal open circuit voltage	24 V DC	None
Output port type	Open collector NPN	None
Common pole	True	OUT GND
Protection	short-circuit / over-current / Reverse voltage	None
Protection circuit	PTC Resettable Fuse	None
Maximal sink current	36 mA	None
Trip current	71 mA	Self-restarting when failure mode current disconnected
Inductive loads	false	None
Effect of incorrect output terminal connection	Protected against reverse voltage connection	None
Maximal output dropout	1 V	Sink current 25 mA
Output delay - ON -> OFF	26us	VOUTPUT=10 V,TAMBIENT=25 °C
Output delay - OFF -> ON	1.5us	VOUTPUT=10 V,TAMBIENT=25 °C
Strobe output mapping	True	None

Table 31: General info for optically isolated digital output

2.10.3 Non-isolated digital lines - Digital Input-Output (INOUT)

The description of non-isolated digital lines below applies to:
all models in this manual (refer to the table [Models and sensors overview](#))

Item	Parameter	Note
Maximal input voltage	24 V DC	None
Common pole	YES	None
Effect of incorrect input terminal connection	Reverse voltage polarity protected	None
Effects when withdrawing/inserting input module under power	no damage, no lost data	None
Protection	short-circuit / over-current / Reverse voltage	None
Maximal output sink current	30 μ A	Maximal advised load = 60 k Ω
Inductive loads	false	None
Output Level logical 0	< 0.4 V	Load 100 k Ω
Output Level logical 1	> 2.5 V	Load 100 k Ω
Output delay - rising edge	400 ns	Load 100 k Ω threshold 2 V
Output delay - falling edge	450 ns	Load 100 k Ω threshold 0.5 V
Input Impedance- minimum	15 k Ω	None
Input Level for logical 0	< 0.7 V	None
Input Level for logical 1	> 2.4 V	None
Input debounce filter	NO	None
Input delay - rising edge	750 ns	VINPUT=5 V
Input delay - falling edge	1200 ns	VINPUT=5 V
Input functions	Trigger	Rising or falling edge are supported for trigger
Output functions	false	Signal inversion supported

Table 32: General info for non-isolated digital in/out trigger lines

2.11 Accessories

2.11.1 CBL-PB4-PWR-0M15

Power cable with barrel connector 15 cm long.



Figure 22: CBL-PB4-PWR-0M15

Manufacturer	Model	Description
Molex	86053120	4 pin Pico Blade connector
NINIGI	PC-GP2.1N	Barrel connector 5.5/2.1

Table 33: CBL-PB4-PWR-0M15 description

2.11.2 CBL-PB6-PT-0M30



Figure 23: CBL-PB6-PT-0M30

IO pig tail cable 30 cm long.

Manufacturer	Model	Description
Molex	2181120603	6 pin Pico Blade connector

Table 34: CBL-PB6-PT-0M30 description

2.11.3 CBL-ECUE-X4G3-1M0/2M0/3M0

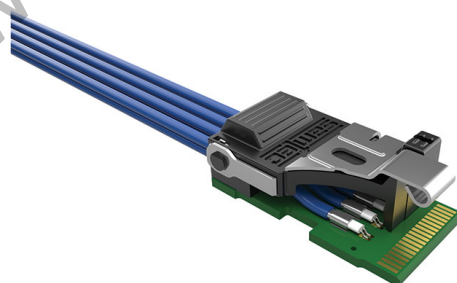

Figure 24: CBL-ECUE-X4G3-1M0

The FireFly copper cables are bidirectional and flexible. PCIe Gen3 x4 lanes with 14 Gbps. Both sides are equipped with locking mechanism. Please check the [Accessories overview](#) for supported lengths of the FireFly cables.

Cameras can be connected to host via cable with FireFly connector. The EMI/EMC performance should be evaluated by customer. For connecting to different host via vast range of adapters, please see our website [Cameras Adapters](#)

2.11.4 CBL-HQCD-0M15

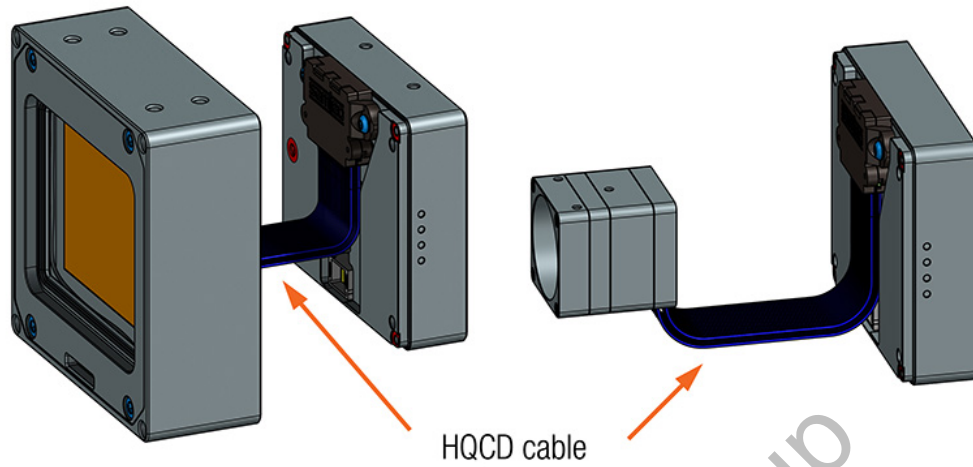

Figure 25: HQCD cable

A MX X4G3 cameras in the manual have front and rear sub-assembly detached option.

Please check the [Accessories overview](#) for supported lengths of the HQCD cables.

Aegis Electronic Group
www.aegiselect.com

2.11.5 CB-X8G3-FAN-COOLER



Figure 26: CB-X8G3-FAN-COOLER

The camera needs to have proper cooling to ensure optimal performance. A fan cooling element can be included with the camera. This fan module is designed to provide air cooling for the camera and can be mounted on the backside of the camera.

To attach or detach the fan module, you will need a hex 2.0 screwdriver and four M2.5x14 screws. When removing or inserting the fan assembly, it's important to be careful not to damage the spring pins that connect the cooling unit to the camera electronics.

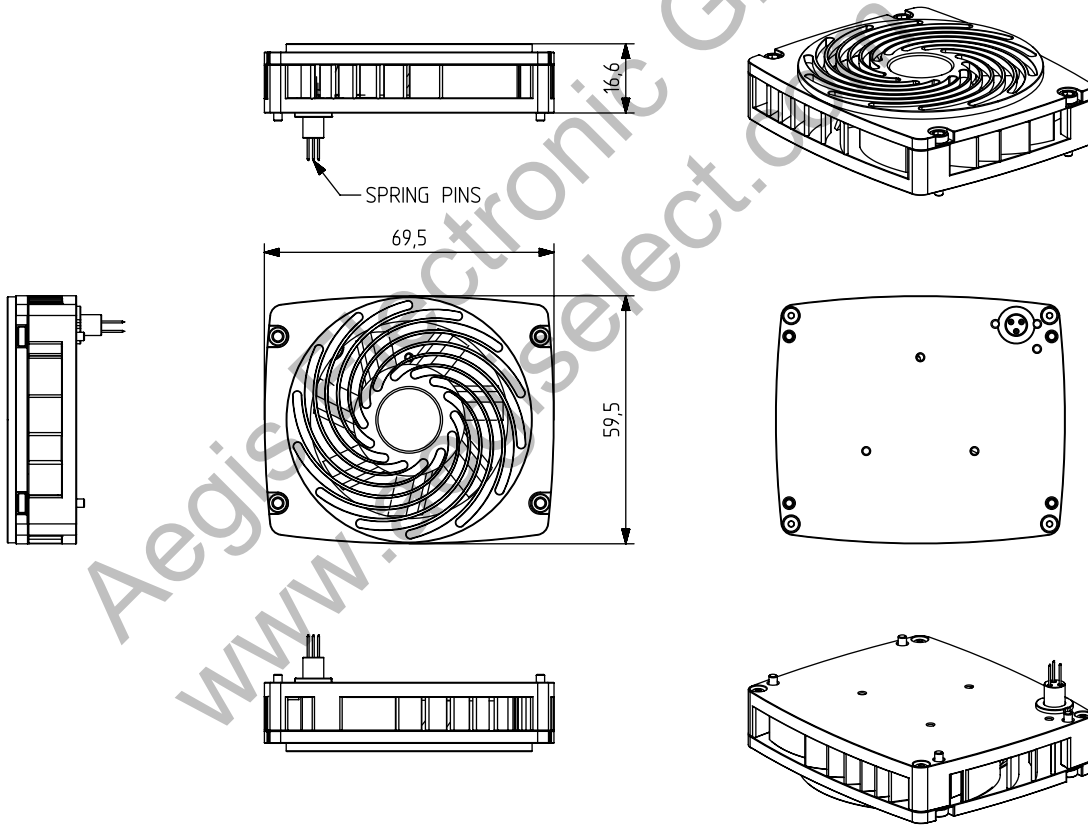

Figure 27: Dimensional drawing of CB-X8G3-FAN-COOLER

Width [W]	Height [H]	Depth [D]	Mass [M]
60 mm	70 mm	17 mm	20 g

Table 35: Mechanical parameters of CB-X8G3-FAN-COOLER

2.11.6 CB-X8G3-WAT-COOLER-KIT

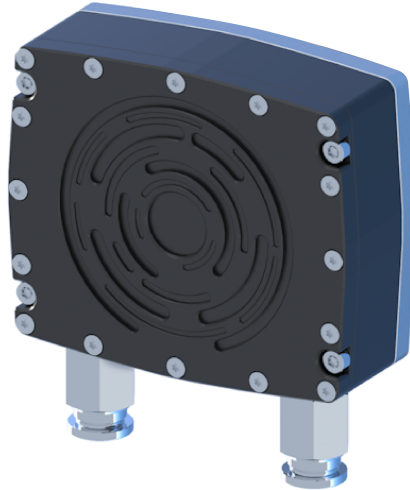

Figure 28: CB-X8G3-WAT-COOLER

A heatsink water cooler from anodized aluminum with a screws kit is available for X8G3/X4G3 cameras. This water cooling option is designed to prevent vibrations and can be conveniently mounted on the backside of the camera.

- 1 SSC6 - M5 quick coupler with airtight washer for 6 mm tubes (water rated)
- 2 6061 aluminum housing with optimized water flow and cooling abilities
- 3 airtight sealing (tested at 10 bars)
- 4 M 2.5 x 18 screws for mounting cooler

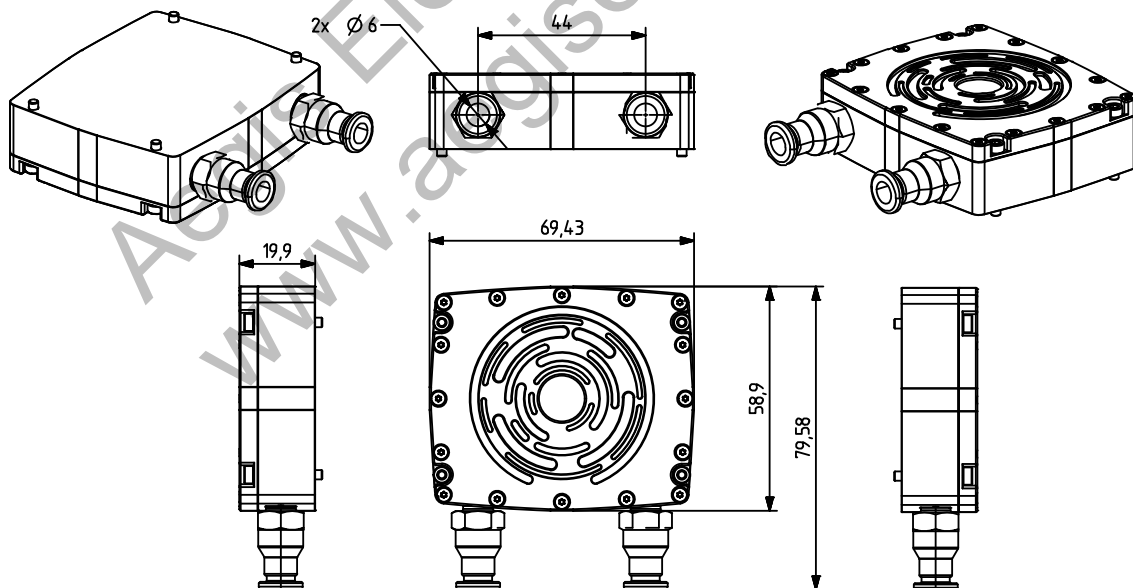

Figure 29: Dimensional drawing of CB-X8G3-WAT-COOLER-KIT

Connecting and disconnecting the tubes

There are various 6 mm OD tubes available from multiple manufacturers that can be used with the camera. It is recommended to consult the websites of the push-in fitting manufacturer for a list of compatible tubes and specific tube specifications necessary to ensure a leak-free connection. Adherence to their provided installation instructions is crucial. Always conduct a leak inspection after making tube connections. XIMEA disclaims any liability for damages resulting from improper installation. Following these guidelines correctly is vital for protecting your equipment and ensuring its peak performance.

XIMEA has conducted tests and endorses the use of PISCO brand tubes (part number UCQ06-2F-20-C) along with insert rings (part number WR0640) for creating secure and leak-proof connections. The recommended procedure for connecting and disconnecting tubes is as follows

Connecting

- Begin by inserting the insert rings into the tubes.

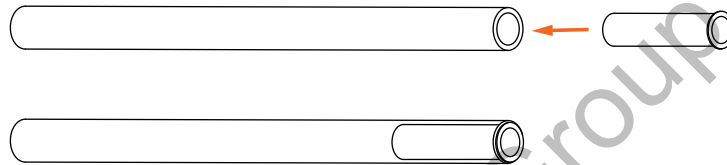

- Ensure the camera is powered off. Then, insert the tube into the Push-In Fitting until it is fully seated. The collet/release ring will automatically secure the tube, and the elastic sleeve will form a seal around it.

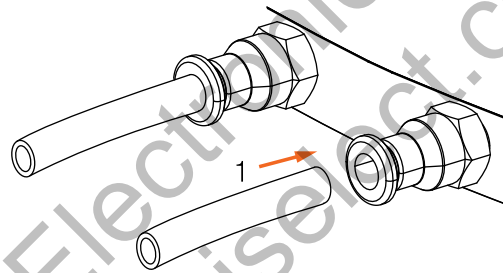

- Gently pull on the tube to verify it is securely fixed and cannot be removed easily.
- Start water supply and inspect for any leaks.
- If no leaks are detected, it is safe to power on the camera.

Disconnecting

- Turn off the camera and halt the water supply.
- Press the collet (release ring) towards the fitting (Step 1).
- While keeping the collet pressed, gently push the tube further into the fitting (Step 2), then pull it out to disconnect (Step 3).

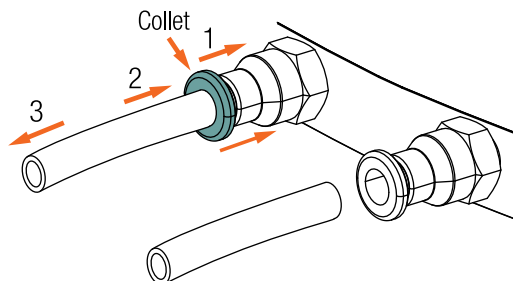

2.11.7 MECH-60MM-BRACKET-T

Bracket is made of solid high quality anodized aluminum. All threads are milled and all edges chamfered. Use 2x M4 screws provided with bracket as a kit for mounting. Bracket can be mounted on the bottom or side of the camera (depending on the camera model).

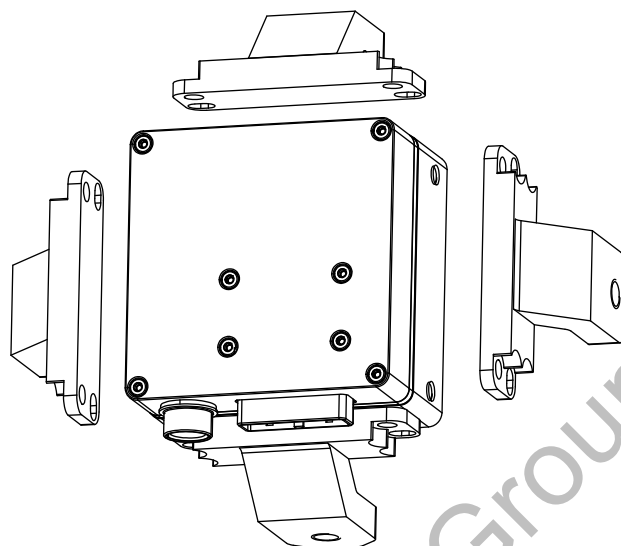

Figure 30: MECH-60MM-BRACKET-T

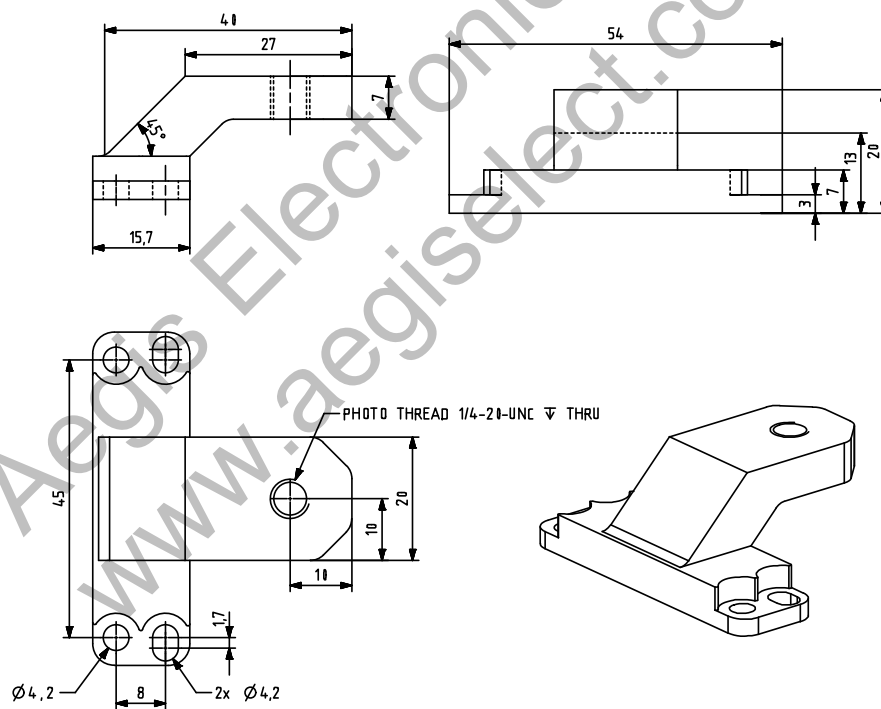

Figure 31: Dimensional drawing of MECH-60MM-BRACKET-T

Width [W]	Height [H]	Depth [D]	Mass [M]
54 mm	20 mm	40 mm	20 g

Table 36: Parameters of MECH-60MM-BRACKET-T

2.11.8 MQ-BRACKET-T



Figure 32: MQ-BRACKET-T

Tripod mounting bracket with 1/4-20 thread. Use 4x SROB-M2x4-CUST screws for mounting. Bracket can be mounted on the bottom or top side of the camera. Brackets are delivered as kit with respective screws. There are two variants. Standard MQ-BRACKET-T-KIT with height of 5.5 mm and thick MQ-BRACKET-T-THICK-KIT for use with lenses with diameter > 37 mm³⁷

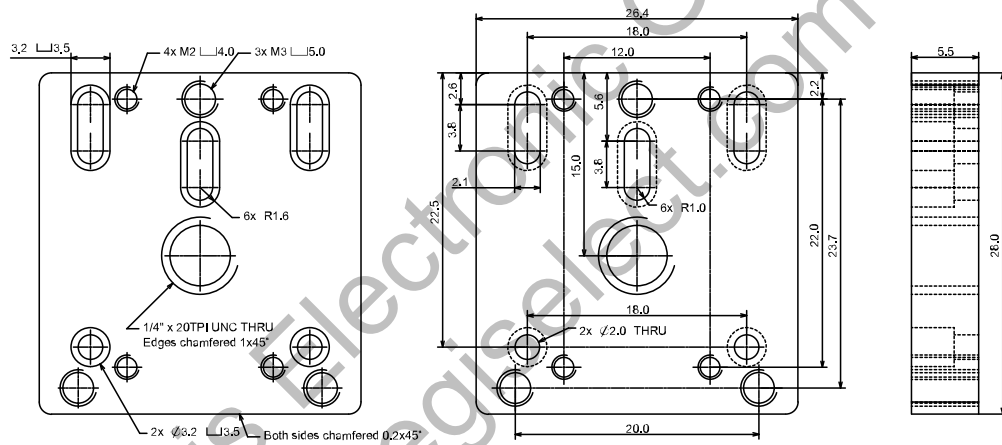

Figure 33: MQ-BRACKET-T dimensional drawing

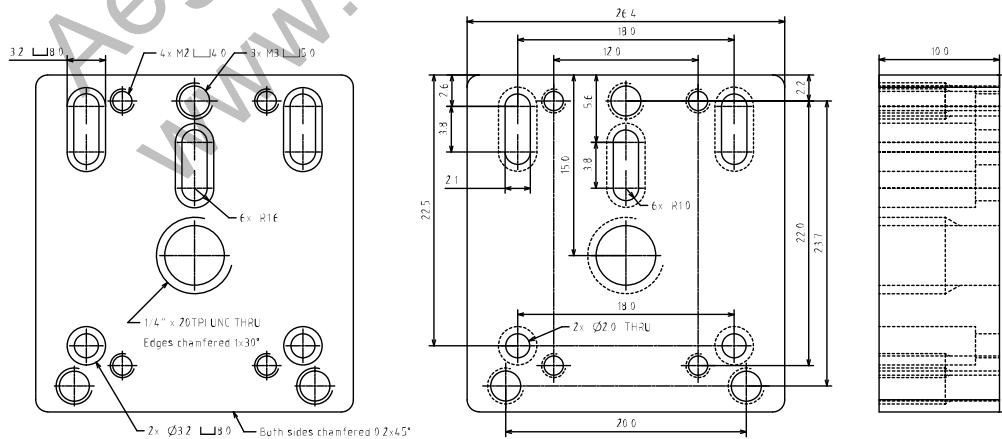

Figure 34: MQ-BRACKET-T thick dimensional drawing

2.11.9 ADPT-MX-X4G3-FF-X4G3-MTP



Back part attachment to connect XIMEA Firefly cameras to MTP cable. Converts 1x PCIe Gen3 x4 camera. The camera adapter also offers power and IO connectors for synchronization and triggering.

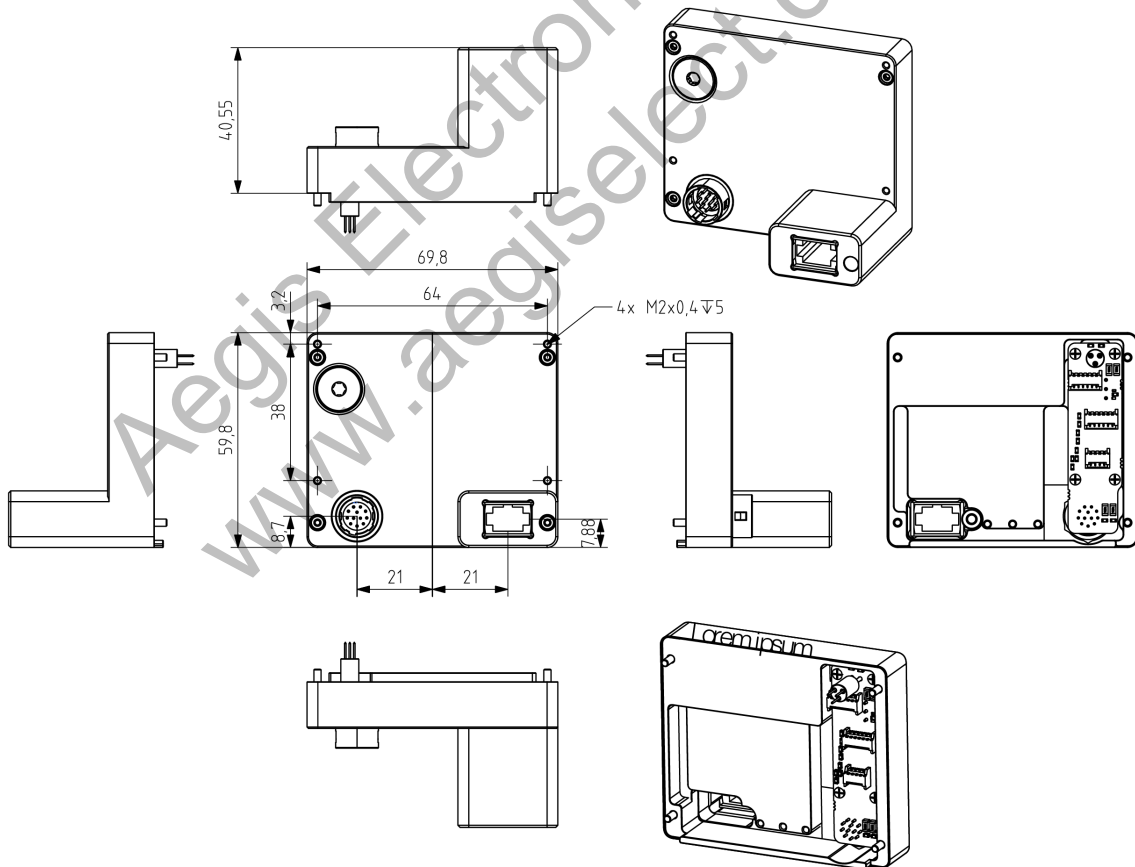

Figure 35: ADPT-MX-X4G3-FF-X4G3-MTP dimensional drawing

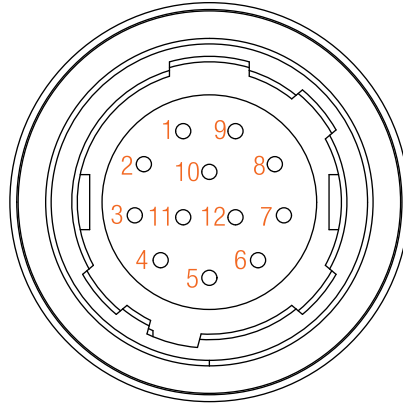

Figure 36: ADPT-MX-X4G3-FF-X4G3-MTP IO connector

The IO pins of the adapter are connected to the corresponding IO pins on the FireFly camera, based on their names.

Pin	Name	Signal
1	IN2	Opto-isolated Input 2
2	IN1	Opto-isolated Input 1
3	OUT2	Opto-isolated Output 2
4	OUT1	Opto-isolated Output 1
5	AUX PWR	Power supply input
6	GND	External grounds for power and non-isolated I/O
7	INOUT1	Non-isolated I/O
8	INOUT3	Non-isolated I/O
9	INOUT2	Non-isolated I/O
10	IN GND	Ground for Opto-Isolated Inputs (IN1, IN2)
11	OUT GND	Ground for Opto-Isolated Out (OUT1, OUT2)
12	INOUT4	Non-isolated I/O

Table 37: ADPT-MX-X4G3-FF-X4G3-MTP IO pin assignment

ADPT-MX-MTP-FAN-COOLER

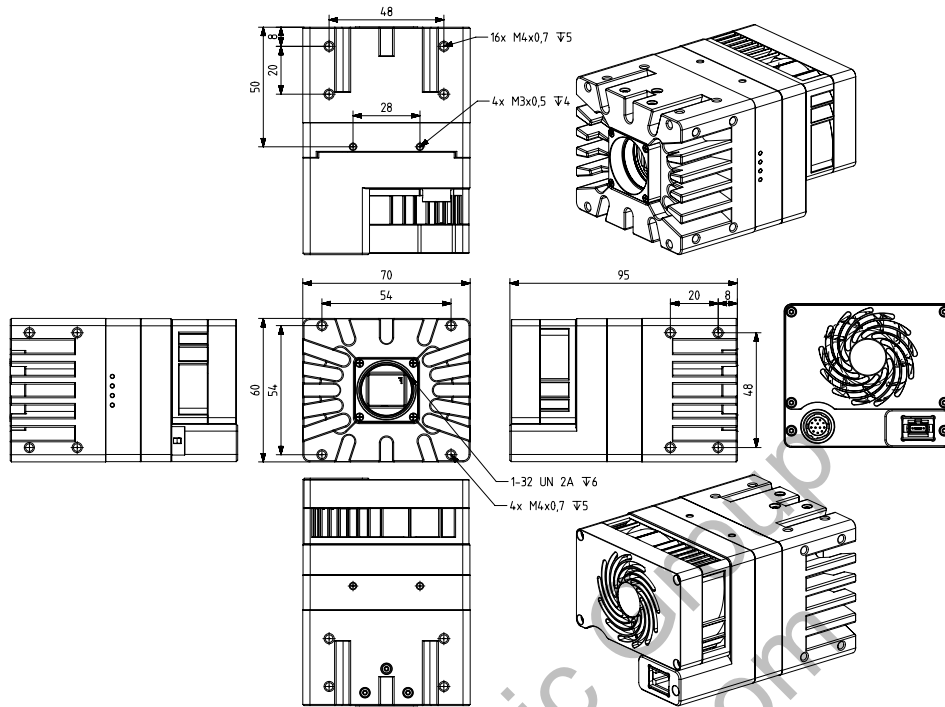

Figure 37: Dimensional drawing MX1611203I245xG-SY-X4G3-xxx

ADPT-MX-MTP-WAT-COOLER

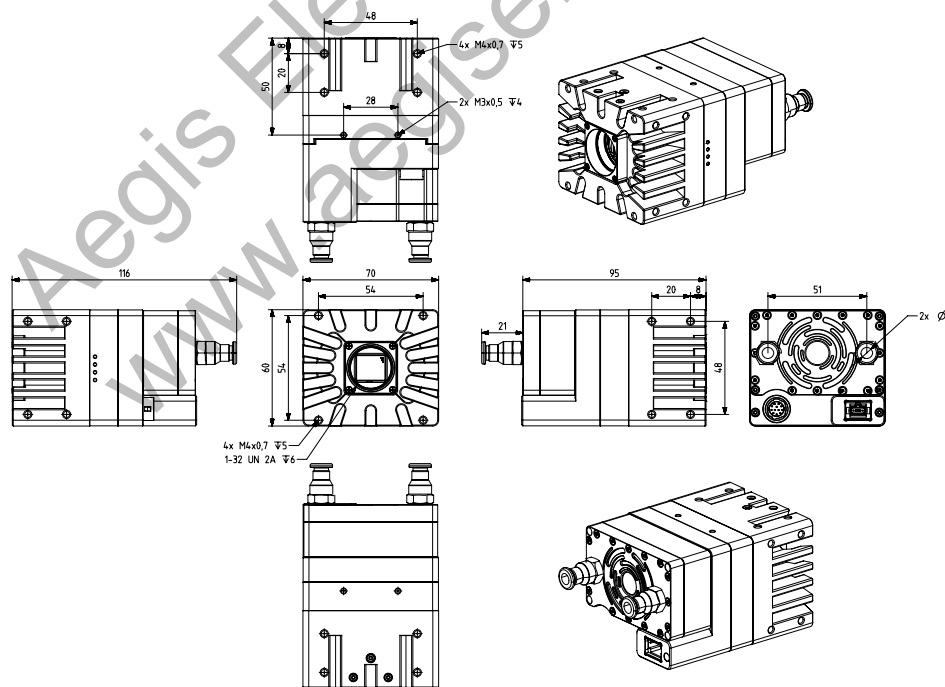

Figure 38: Dimensional drawing MX1611203I245xG-SY-X4G3-xxx-MTP-WATERCOOLED

2.11.10 CBL-MT-PWR-SYNC-3M0

The following is a description of the sync/power cable.
 Get the latest information on available accessories at: [PCI Express Cameras](#)

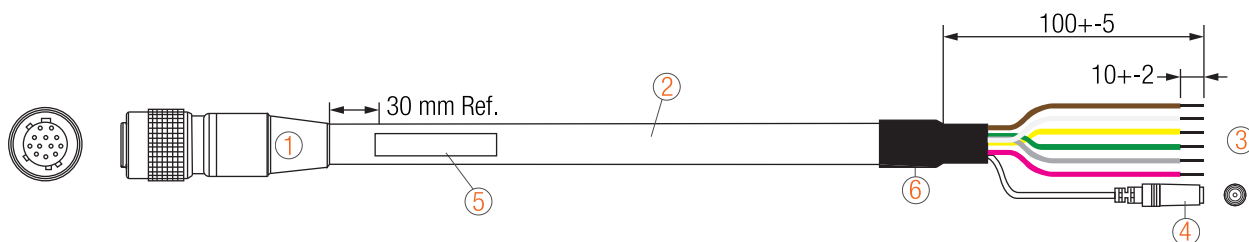

Figure 39: CBL-MT-PWR-SYNC-3M0 drawing

sync + power cable, components

- 1 Series60 Female Circular Plug 60-01-1112 IO <BLK>
- 2 TBAUL20276 4STP#28 + 4C#28 + 2C#24 [OD=6.80mm] <BLK>
- 3 Process end with wire end stripped and tin soldered
- 4 DC power in socket female (OD5.5/ID2.1) <BLK>
- 5 Cable label
- 6 Heat shrinkable tube

Pin	1	2	3	4	5	6	7	8	9	10	11	12
Signal	IN2	IN1	OUT2	OUT1	AUX PWR	GND	INOUT1	INOUT3	INOUT2	IN GND	OUT GND	INOUT4

Table 38: CBL-MT-POWER-SYNC-3M0 pin assignment

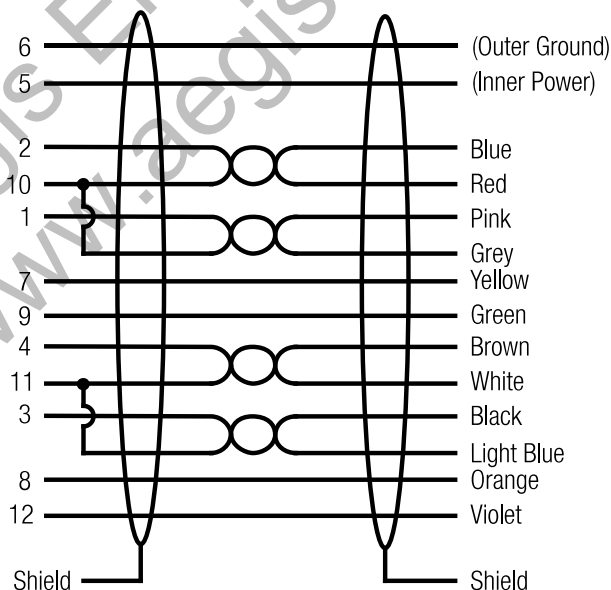

Figure 40: Wiring diagram of the CBL-MT-POWER-SYNC-3M0

2.11.11 ADPT-MX-X4G3-FF-X4G3-SFF

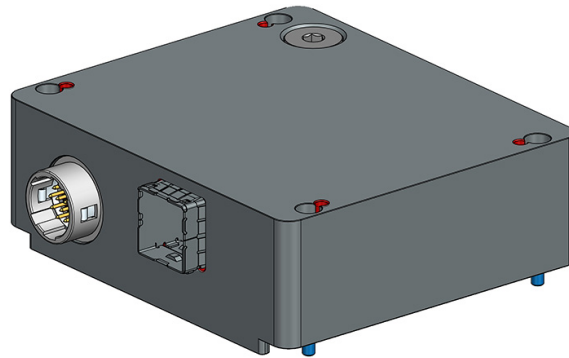

Figure 41: ADPT-MX-X4G3-FF-X4G3-SFF

Back part attachment to connect XIMEA Firefly cameras to SFF-8644 cable. Converts 1x PCIe Gen3 x4 camera.

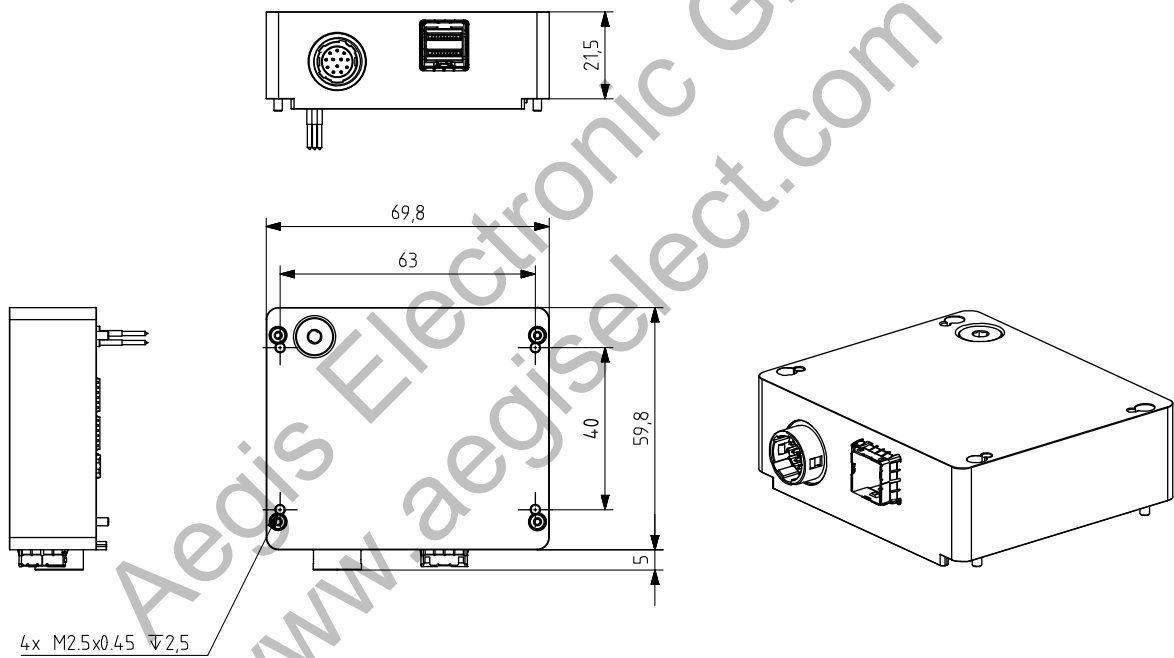

Figure 42: ADPT-MX-X4G3-FF-X4G3-SFF dimensional drawing

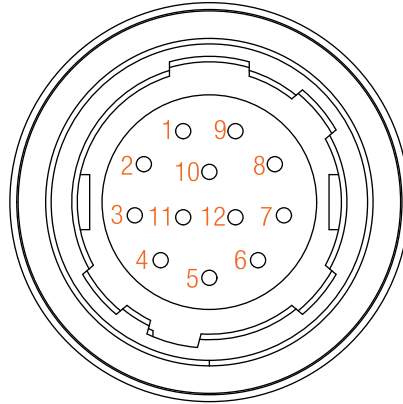

Figure 43: ADPT-MX-X4G3-FF-X4G3-SFF IO connector

The IO pins of the adapter are connected to the corresponding IO pins on the FireFly camera, based on their names

Pin	Name	Signal
1	IN2	Opto-isolated Input 2
2	IN1	Opto-isolated Input 1
3	OUT2	Opto-isolated Output 2
4	OUT1	Opto-isolated Output 1
5	AUX PWR	Power supply input
6	GND	External grounds for power and non-isolated I/O
7	INOUT1	Non-isolated I/O
8	INOUT3	Non-isolated I/O
9	INOUT2	Non-isolated I/O
10	IN GND	Ground for Opto-Isolated Inputs (IN1, IN2)
11	OUT GND	Ground for Opto-Isolated Out (OUT1, OUT2)
12	INOUT4	Non-isolated I/O

Table 39: ADPT-MX-X4G3-FF-X4G3-SFF IO pin assignment

ADPT-MX-SFF-FAN-COOLER

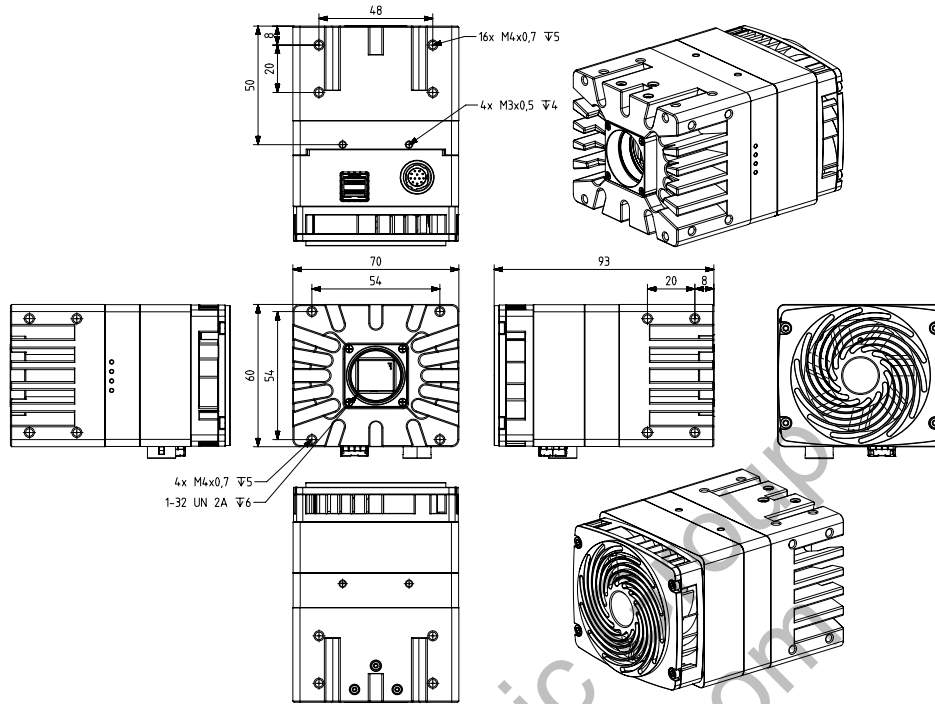

Figure 44: Dimensional drawing MX1611203|245xG-SY-X4G3-xxx-SFF-AIRCOOLED

ADPT-MX-SFF-WAT-COOLER

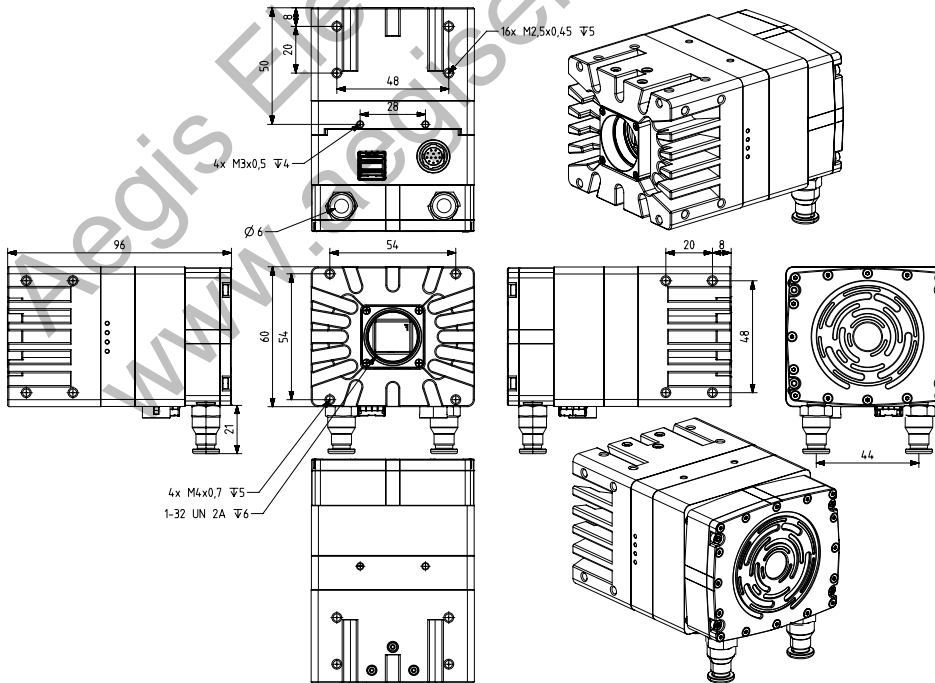

Figure 45: Dimensional drawing MX1611203|245xG-SY-X4G3-xxx-SFF-WATERCOOLED

2.11.12 FireFly MTP adapters

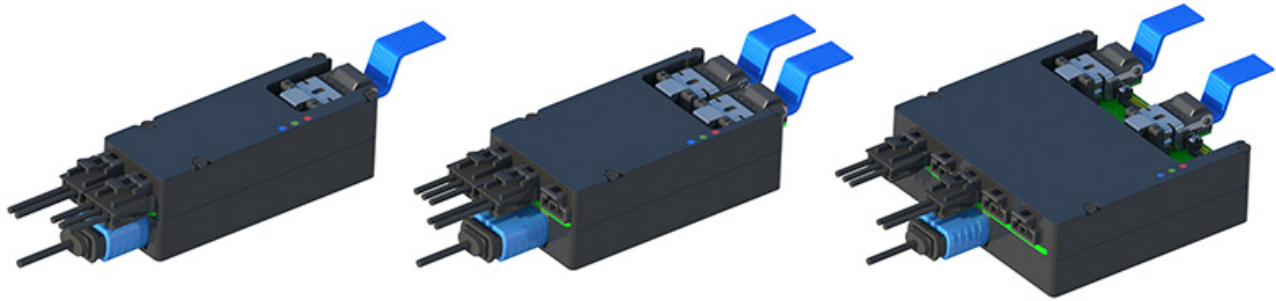

Figure 46: FireFly to MTP adapters

Adapter to connect XIMEA FireFly cameras to MTP cable.

The camera/s should be connected to these adapters over a FireFly ECUE copper cable (e.g. 10 cm - 3 m). The adapter has an integrated PCUO module, which allows connection to PC over optical MTP cable (e.g. 10 m). Adapters contain also connectors for power and GPI/GPO from the camera. The power cable is going to be bundled with the adapter delivery and sync cable is optional.

ADPT-1P-X4G3-FF-X4G3-MTP

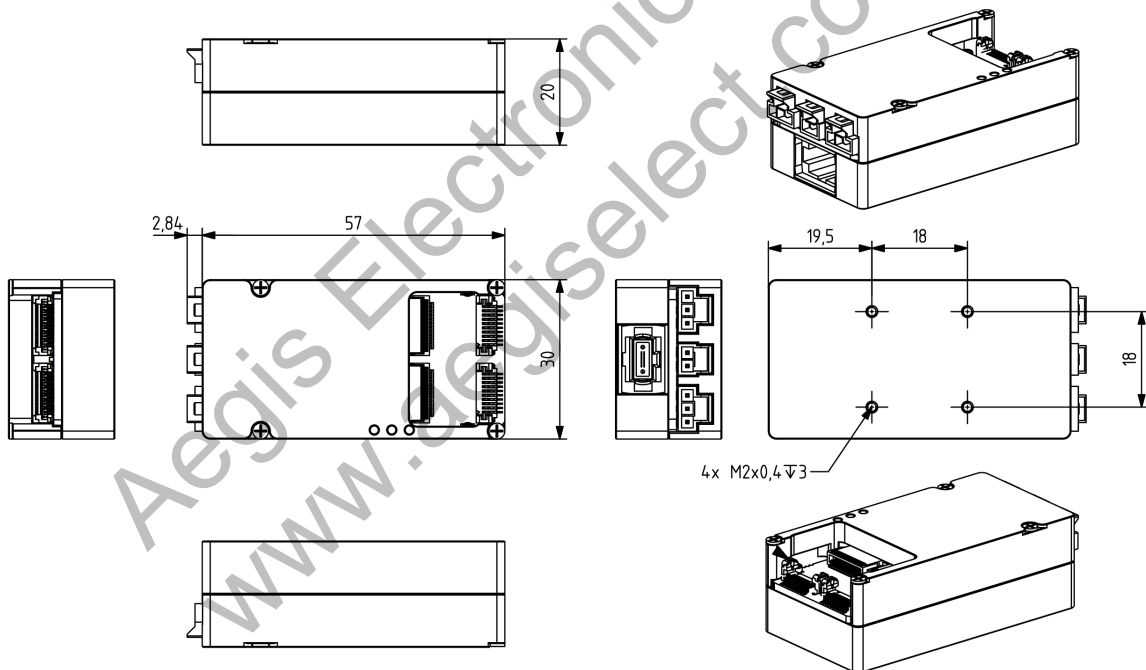

Figure 47: ADPT-1P-X4G3-FF-X4G3-MTP dimensional drawings

ADPT-1P-X8G3-FF-X8G3-MTP / ADPT-2P-X2G3-FF-X4G3-MTP

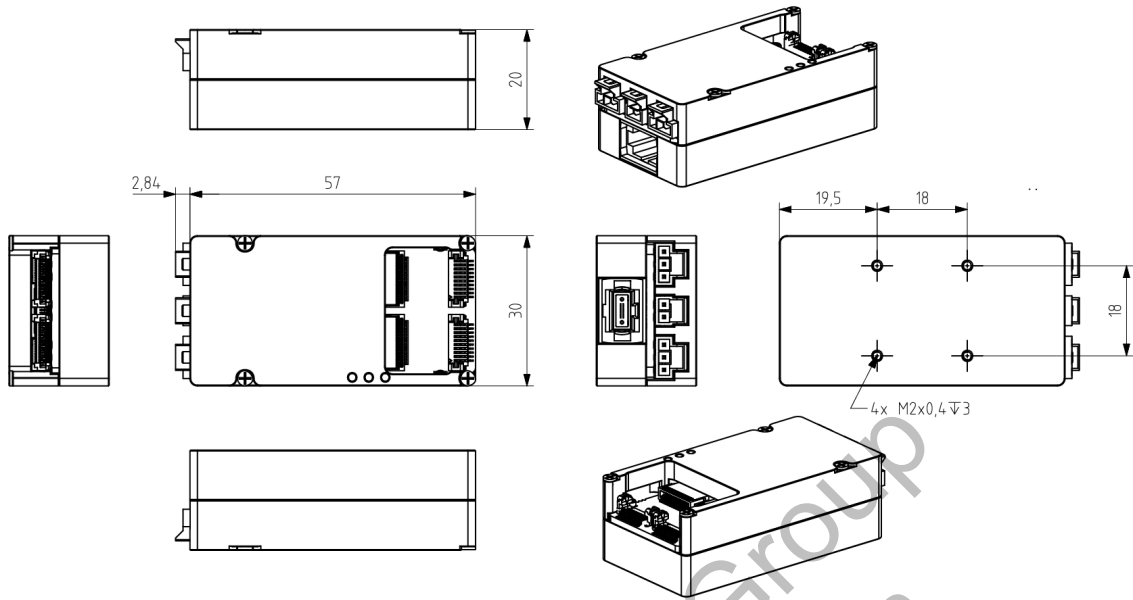

Figure 48: ADPT-1P-X8G3-FF-X8G3-MTP and ADPT-2P-X2G3-FF-X4G3-MTP dimensional drawings

ADPT-4P-X2G3-FF-X8G3-MTP

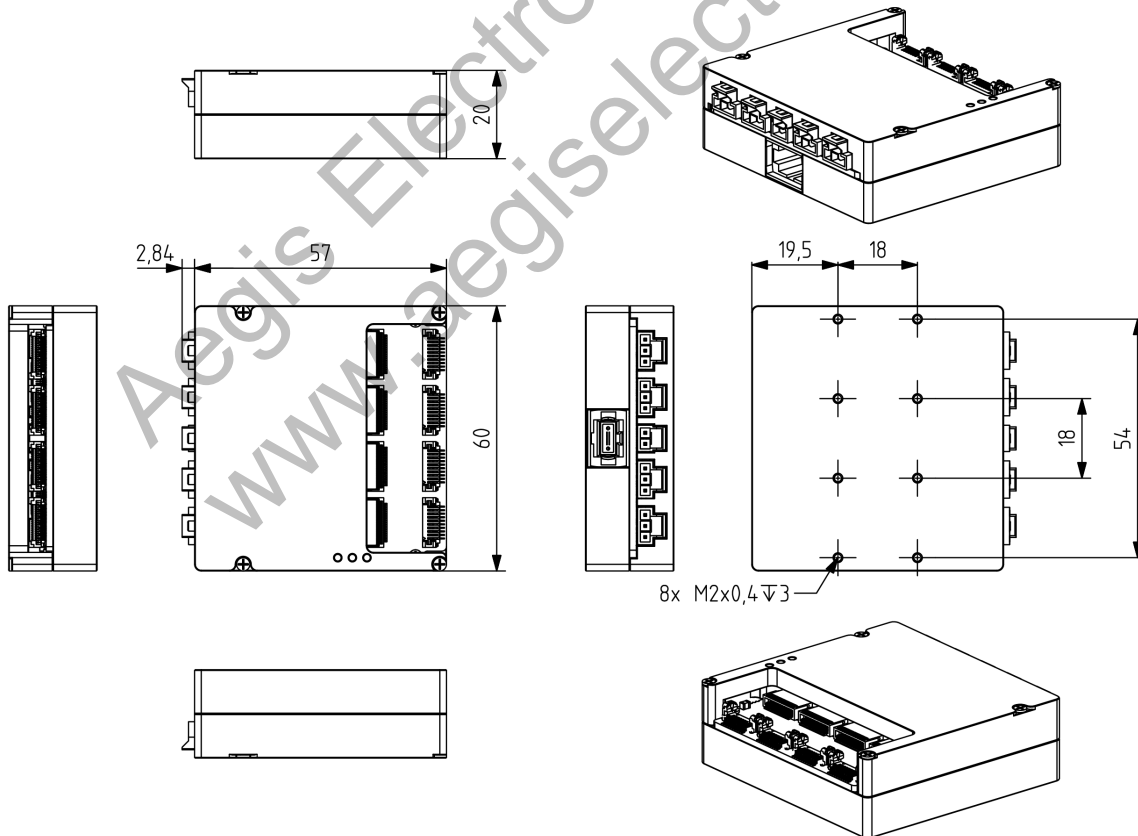

Figure 49: ADPT-4P-X2G3-FF-X8G3-MTP dimensional drawings

2.11.13 PCIe host adapters

Supports PCIe Gen3 x4 lines and requires PCIe Gen.3 x8 slot on the computer side. Bandwidth of 32 Gbps. Cable lengths of up to 100 m.

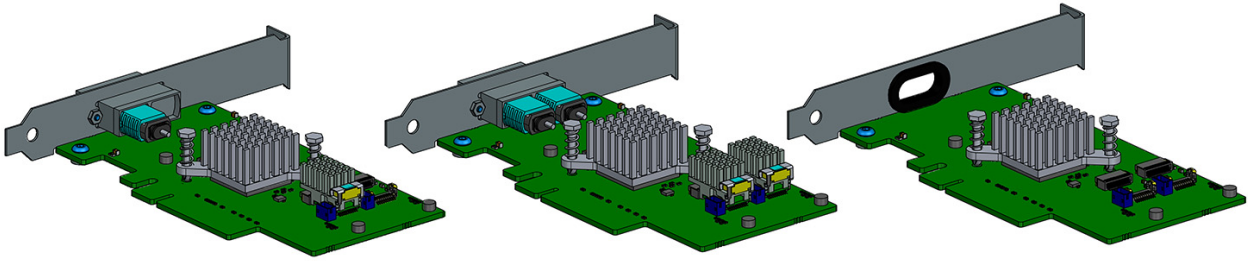

Figure 50: PCIe host adapters

HA-1P-X4G3-MTP-X8G3 / HA-2P-X4G3-MTP-X8G3

PCIe MTP Gen3 x4 Host Adapter - single or dual port for MTP fiber optic cables.

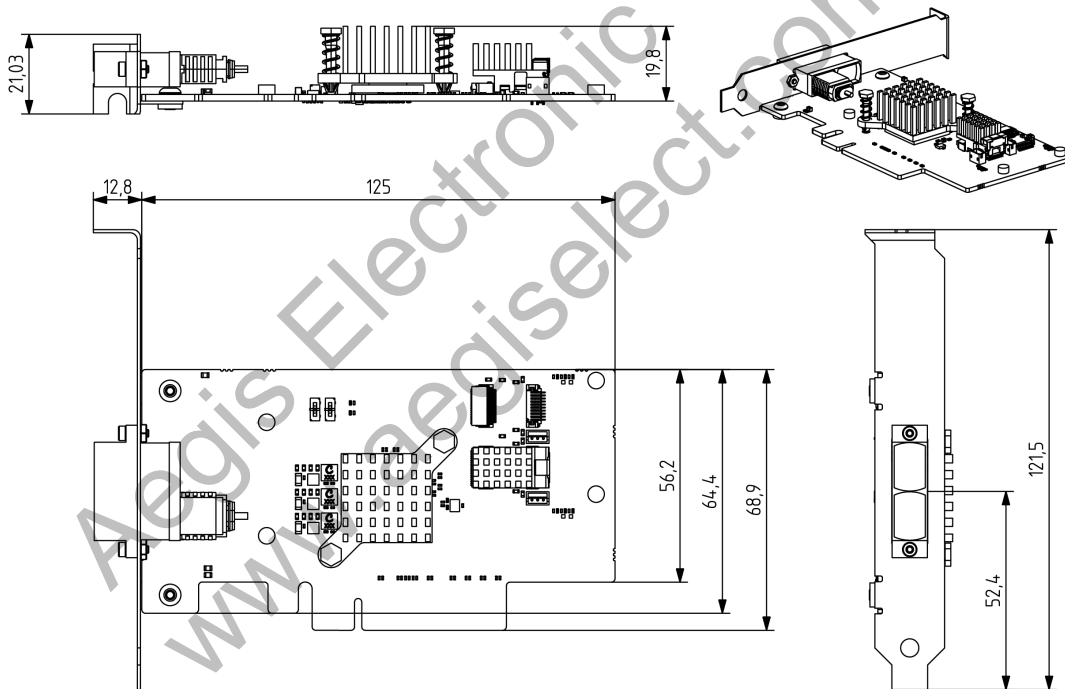

Figure 51: Dimensional drawing of host adapter HA-1P-X4G3-MTP-X8G3

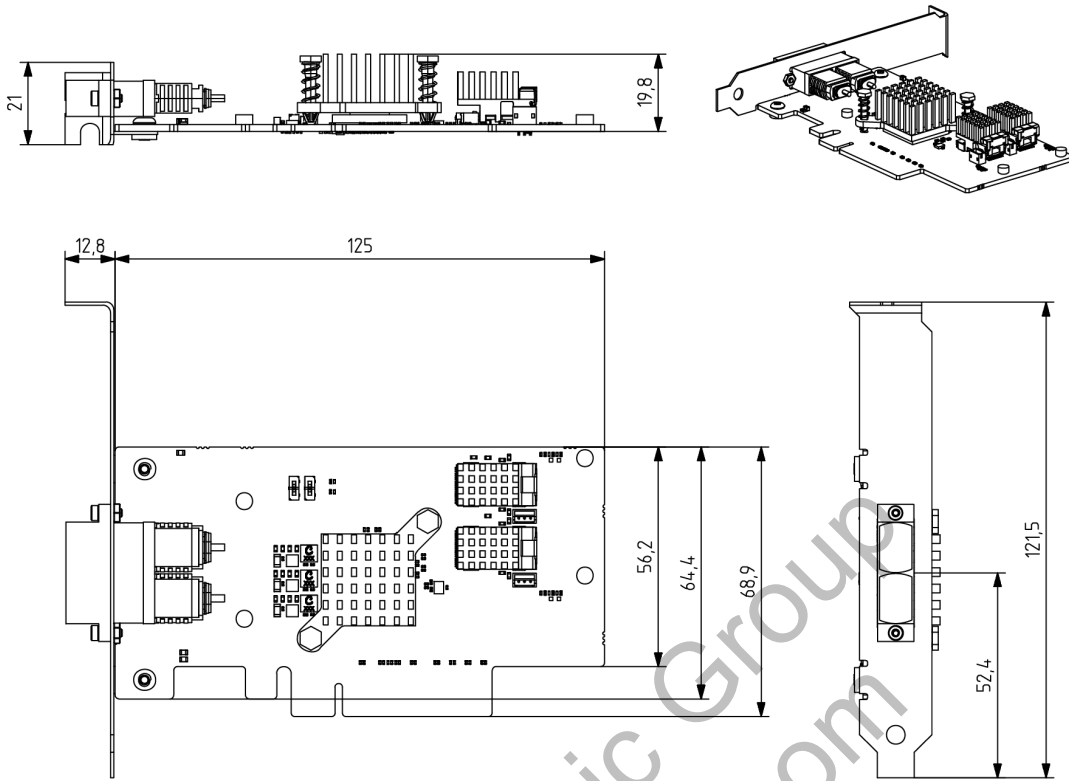

Figure 52: Dimensional drawing of host adapter HA-2P-X4G3-MTP-X8G3

HA-2P-X4G3-FF-X8G3

PCIe FireFly Host Adapter Dual - dual ports for Firefly cables.

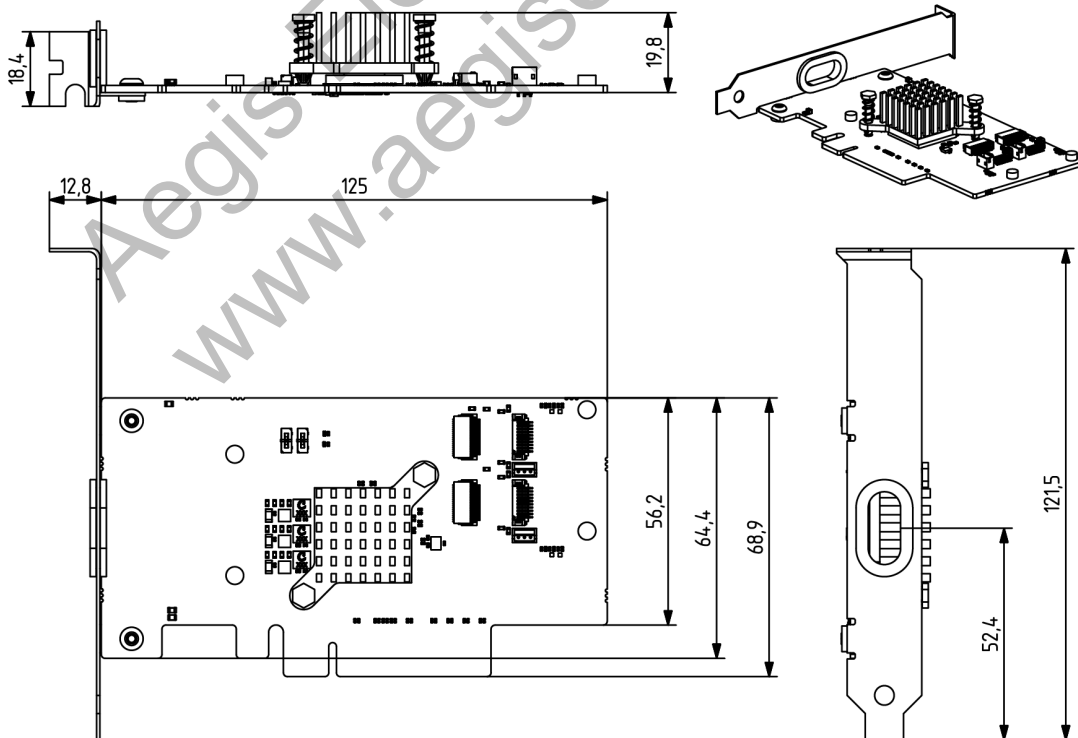

Figure 53: Dimensional drawing of host adapter HA-2P-X4G3-FF-X8G3

3 General features

3.1 Camera features

3.1.1 ROIs – Region of interest

ROI, also called area-of-interest (AOI) or windowing, allows the user to specify a sub-area of the original sensor size for read-out. ROI can be set by specifying the size (width and height) as well as the position (based on upper left corner) of the sub-area.

3.1.2 Downsampling modes

Downsampling describes the possibility of reducing the image resolution without affecting the sensors physical size, i.e. without reducing the physical size of the sensing area. This feature is useful when optics are used, that are particularly fitted to a certain sensor size and if it is necessary to maintain the full image circle on the sensor.

Downsampling can be achieved in two ways: binning and decimation.

Binning/decimation selector selects which binning/decimation engine is used (Sensor, FPGA, CPU). After setting of selector, multiple parameters could be get or set for the selected unit.

They can be divided into:

- Patterns** define the horizontal/vertical pattern how photo-sensitive cells are combined (mono or bayer)
- Values** reduce the horizontal or vertical resolution of the image by the specified horizontal/vertical downsampling factor
- Modes** in case of binning set the mode used to combine horizontal/vertical photo-sensitive cells together (sum or average)

Binning

When binning is applied, the image is divided into cluster of $k \times l$ pixels, where all pixels in each cluster are interpolated and result in the value of one output pixel. For example, a 2×2 binning produces 2×2 -pixel clusters and results in images with $\frac{1}{4}$ of the original resolution.

Decimation – Skipping

When decimation is chosen, only every n -th pixel is used to create the output image. For example, with a 2×1 vertical skipping, every odd number line is used and every even number line is skipped, resulting in an image with half its original vertical resolution. Skipping is a faster downsampling mode, but also introduces more aliasing effects.

3.1.3 Image data output formats

All modes are provided by the xiAPI or standard interfaces using the xiAPI (please see [Programming](#)). Each camera model supports several Image Data Output Formats.

This table is applicable to:

MX161CG-SY-X4G3-FF

MX203CG-SY-X4G3-FF

MX245CG-SY-X4G3-FF

Mode	Description
XI_MONO8	8 bits per pixel. [Intensity] ^{1,2}
XI_MONO16	16 bits per pixel. [Intensity LSB] [Intensity MSB] ^{1,2}
XI_RAW8	8 bits per pixel raw data from sensor. [pixel byte] raw data from transport (camera output)
XI_RAW8X2	8 bits per pixel raw data from sensor(2 components in a row)
XI_RAW16	16 bits per pixel raw data from sensor. [pixel byte low] [pixel byte high] 16 bits (depacked) raw data
XI_RAW16X2	16 bits per pixel raw data from sensor(2 components in a row)
XI_RGB16_PLANAR	RGB16 planar data format
XI_RGB24	RGB data format. [Blue][Green][Red] ¹
XI_RGB32	RGBA data format. [Blue][Green][Red][0] ¹
XI_RGB48	RGB data format. [Blue low byte][Blue high byte][Green low][Green high][Red low][Red high] ¹
XI_RGB64	RGBA data format. [Blue low byte][Blue high byte][Green low][Green high][Red low][Red high][0][0] ¹
XI_RGB_PLANAR	RGB planar data format. [Red][Red]...[Green][Green]...[Blue][Blue]... ¹
XI_FRM_TRANSPORT	Data from transport layer (e.g. packed). Depends on data on the transport layer ³

¹Higher CPU processing is required when this mode is selected because color filter array processing is implemented on PC. This processing is serialized when multiple cameras is used at once. The most effective way to get data from camera is to use XI_RAW8, where no additional processing is done in API.

²On monochromatic cameras the black level is not subtracted in XI_MONO8 and XI_MONO16 formats by Image Processing in xiAPI, so black level remains the same as in RAW format.

³When using Transport Data Format, the Image Processing block from XiAPI Image Data Flow is skipped and therefore the Transport format is the most effective data format in terms of CPU and RAM usage.

Table 40: Image data output formats

Mode	Description
XI_MONO8	8 bits per pixel. [Intensity] ^{1,2}
XI_MONO16	16 bits per pixel. [Intensity LSB] [Intensity MSB] ^{1,2}
XI_RAW8	8 bits per pixel raw data from sensor. [pixel byte] raw data from transport (camera output)
XI_RAW8X2	8 bits per pixel raw data from sensor(2 components in a row)
XI_RAW16	16 bits per pixel raw data from sensor. [pixel byte low] [pixel byte high] 16 bits (depacked) raw data
XI_RAW16X2	16 bits per pixel raw data from sensor(2 components in a row)
XI_FRM_TRANSPORT	Data from transport layer (e.g. packed). Depends on data on the transport layer ³

¹Higher CPU processing is required when this mode is selected because color filter array processing is implemented on PC. This processing is serialized when multiple cameras is used at once. The most effective way to get data from camera is to use XI_RAW8, where no additional processing is done in API.

²On monochromatic cameras the black level is not subtracted in XI_MONO8 and XI_MONO16 formats by Image Processing in xiAPI, so black level remains the same as in RAW format.

³When using Transport Data Format, the Image Processing block from XiAPI Image Data Flow is skipped and therefore the Transport format is the most effective data format in terms of CPU and RAM usage.

Table 41: Image data output formats

Aegis Electronic Group
www.aegiselect.com

3.2 Acquisition modes

3.2.1 Free-Run

Also known as continuous acquisition. In this mode the sensor delivers a constant stream of image data at the maximum speed available by the current bandwidth, without any external trigger. Each image exposure is sequentially started automatically when possible.

For all sensors the exposure of the next frame overlaps with the data readout of the previous frame. This Overlap mode gives the highest number of frames per second (FPS).

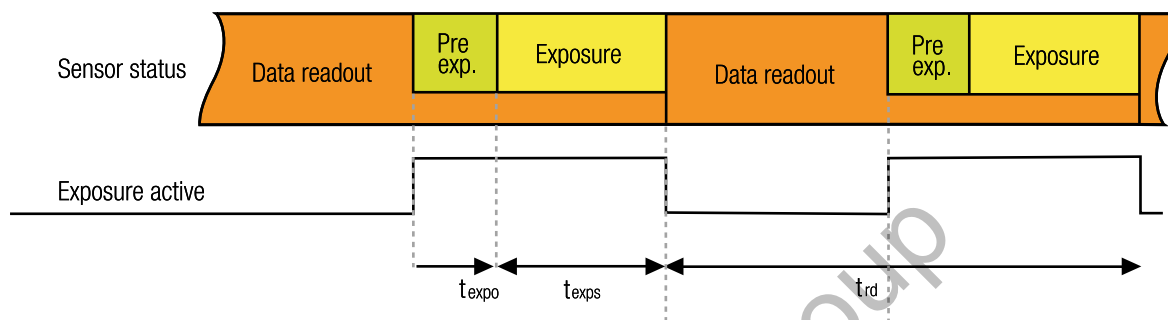

Figure 54: Acquisition mode - free run

The frame rate in free run mode depends inversely on the frame time. In general the frame time roughly equals to the readout time or to the exposure time, depending on which one of the two is larger. This means that when exposure time is larger than the readout time, the frame rate gradually decreases with increasing exposure time ($\text{frame_rate} \sim 1/t_{\text{exp}}$).

In this mode the timing depends on the Exposure Time and Data Readout Time. In situation when the exposure time is comparable or longer than readout time, the exposure active signal might have constant active level during acquisition. This might be caused also by different propagation delay for rising and falling edge of opto isolated outputs. Polarity inversion might help to make visible the separated exposure pulses. Some camera models support limiting of FPS. When set the camera will limit the frame rate so it does not exceed the set value. Please see: [Frame_Rate_Control](#). This is also applicable in case of triggered acquisition.

3.2.2 Trigger controlled acquisition/exposure

Unlike in the free-run, each image exposure can also be triggered with an input trigger signal. In this mode, the sensor waits in stage until the trigger signal arrives. Only then, the exposure of first frame is started, which is followed by the data readout. XIMEA cameras supports several triggered modes along with single image exposure after one trigger. The trigger signal can be either edge sensitive or level sensitive. In the case of "level sensitive", it can be used to control length of exposure or acquisition itself. Generally trigger sources can be divided into two groups:

Software trigger

The trigger signal can be sent to the sensor using a software command. In this case, common system related latencies and jitter apply.

Hardware trigger

A hardware trigger can be sent to the sensor using the digital input. Triggering by hardware is usually used to reduce latencies and jitter in applications that require the most accurate timing. In this case rising edge of input signal is suggested as the delay of opto coupler is smaller as well as introduced jitter. Triggering by hardware is usually used to reduce latencies and jitter in applications that require the most accurate timing.

Triggered mode - Burst of frames

For more information please see: [Frame Burst Modes](#)

Frame Burst Start

In this mode each trigger pulse triggers defined number of exposed frames.

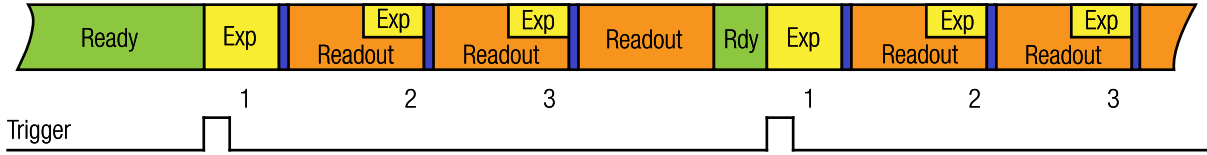

Figure 55: Triggered burst of frames – frame burst start

Frame Burst Active

If trigger is level-sensitive, it can be used to control image acquisition.

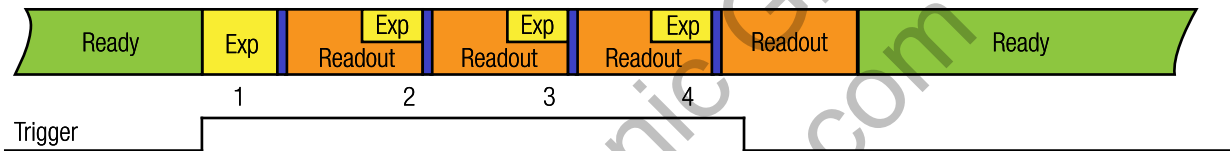

Figure 56: Triggered burst of frames – frame burst active

Triggered mode - Exposure defined by trigger pulse length

In this mode the exposure is defined by trigger pulse length. This can be used to achieve longer exposure than allowed by API. Also, it can be used to trigger several images in sequence with different exposure time. Exposure time is measured and reported in image metadata. Please see: [Exposure Defined by Trigger Pulse Length](#)



Figure 57: Exposure defined by trigger pulse length

Short interval shutter mode

Cameras based on the IMX530, IMX531, IMX532, IMX535, IMX536, IMX537, IMX540, IMX541, IMX542, IMX545, IMX546, and IMX547 sensors support short interval shutter mode. In this mode a pair of consecutive frames can be grabbed with virtually no gap between the end of the exposure of the first frame and start of the exposure of the second frame. This feature is particularly desired in Particle Image Velocimetry (PIV) because it allows positioning two laser pulses with short separation on sequential frames (frame straddling). This feature is supported in free run as well as in triggered acquisition modes. In triggered mode a single trigger will result in a pair of frames.

The lengths of the exposures of both frames are fixed and their exact values depend on the camera's settings (e.g., sensor data bit depth, bandwidth limit etc.). The first exposure (t_{exp1}) is in magnitude of hundreds of microseconds and the second exposure (t_{exp2}) equals to the readout time. The time between the end of the first exposure and start of the second exposure is very short. However, the sensor manufacturer recommends a period (Flash Prohibited Period) with a magnitude of 2 - 3 microseconds during which the flash should not be fired to ensure correct operation. This period is indicated in the exposure active signal which can be forwarded to the camera's digital output. Please note that it is recommended to use the non-isolated outputs of the camera with low capacitance IO cables to ensure low distortion of the output signal.

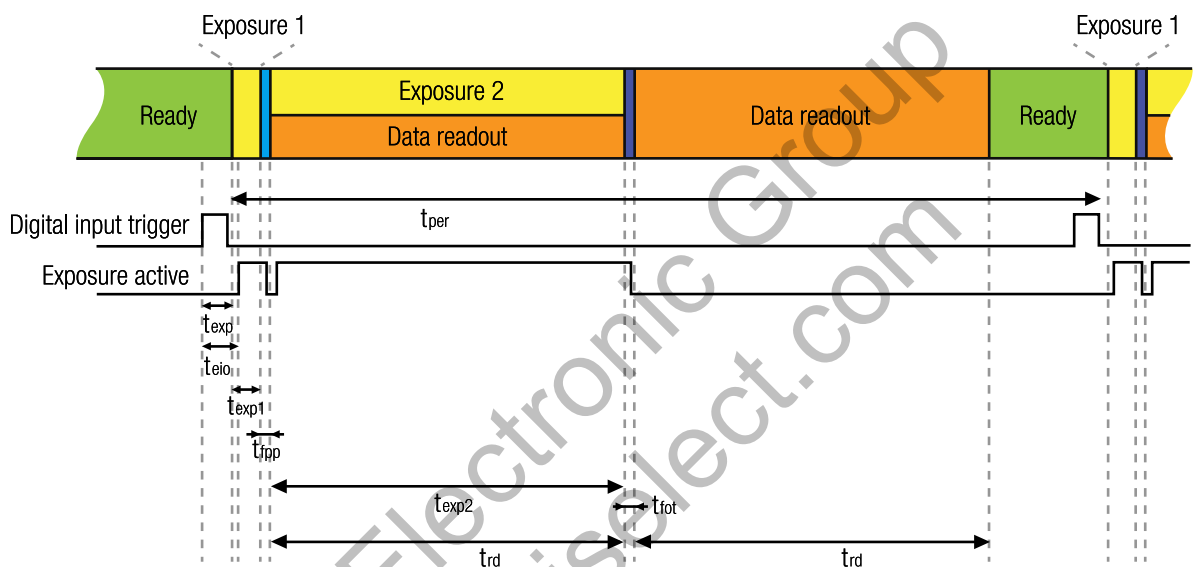

Figure 58: Short interval shutter mode – triggered

- t_{eio} Trigger (Digital Input) to Exposure Active (Digital Output)
- t_{exp} Trigger (Digital Input) to start of exposure
- t_{exp1} TExposure Time of the first image
- t_{exp2} TExposure Exposure Time of the second image
- t_{fpp} Flash Prohibited Period
- t_{fot} Frame overhead time (FOT)
- t_{rd} readout time (Readout Time)

The timing strongly depends on camera settings.

The output signaling is then delayed the delay introduced from the output electronic.

$$t_{eio} = t_{exp} + t_{odelay}$$

t_{odelay} - Delay inside camera caused by internal electronics. This depends on output type. Please refer to [Optically isolated Digital Output \(OUT\)](#)

3.3 Exposure time

Also known as shutter speed. This parameter defines the length of the integration period for each frame. Most CMOS sensors generate the exposure interval internally. For some it is possible to control it by external signaling. The sensor internal timing depends on the provided system clock. Most sensors use dividers to generate slower clocks for internal usage.

The minimum exposure time is defined mostly by row times, where the row time (T_R) is dependent on various internal settings. Very few sensors support exposure times equal to zero. There is a defined minimum exposure time as well as minimum steps between possible exposure times. There is also a maximum exposure time, defined by sensor architecture.

3.4 Gain

The gain value influences the analog-to-digital conversion process of the image sensor pipeline and acts as a multiplier of the output signal. Using gain values greater than 0 will increase the pixel intensities but may also increase the overall noise level. For some camera models the gain can be set in discrete steps only.

Aegis Electronic Group
www.aegiselect.com

3.5 Dual ADC modes

Dual ADC readout modes allow a single exposure to be processed through two distinct readout channels, producing two images with different analog gain settings. The high gain (HG) image benefits from reduced readout noise, resulting in an improved signal-to-noise ratio (SNR) in low-light areas of the scene. Conversely, the low gain (LG) image offers superior SNR in well-illuminated regions by effectively utilizing a larger portion, or the entirety, of the full well capacity.

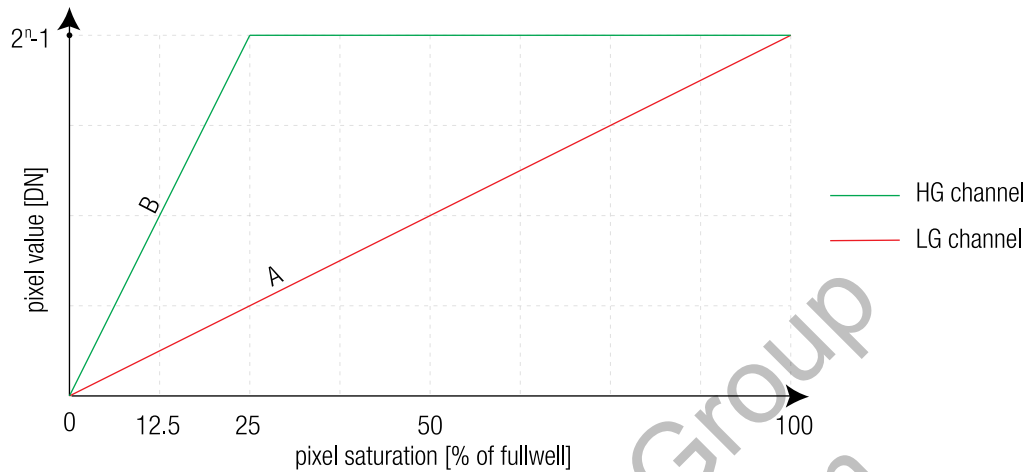

Figure 59: Dual ADC mode non-combined with merging

These two images can be either read out separately from the sensor (Non-combined mode) and transported to the host PC memory or combined in the sensor into a single HDR frame with a piecewise linear response (Combined mode).

```
// Set dual ADC mode to non-combined or combined
xiSetParamInt(xiH, XI_PRM_DUAL_ADC_MODE, XI_DUAL_ADC_MODE_NON_COMBINED);
// or
xiSetParamInt(xiH, XI_PRM_DUAL_ADC_MODE, XI_DUAL_ADC_MODE_COMBINED);
```

The gain parameter is used to define the analog gain of the low gain channel (slope A) and the dual ADC gain ratio parameter is used to adjust the offset/ratio of the analog gain of the high gain channel (slope B / slope A).

```
// Set gain selector to analog
xiSetParamInt(xiH, XI_PRM_GAIN_SELECTOR, XI_GAIN_SELECTOR_ANALOG_ALL);
// Set gain to arbitrary value
xiSetParamFloat(xiH, XI_PRM_GAIN, 0);
// Set gain ratio to arbitrary value
// depending on the gain value the range can be from 0--24 dB
// with 6 dB increment
xiSetParamFloat(xiH, XI_PRM_DUAL_ADC_GAIN_RATIO, 12);
```

3.5.1 Combined mode

Following camera models support Combined mode:
all models in this manual (refer to the table [Models and sensors overview](#))

In the combined mode the HG and LG images are merged directly in the sensor. This mode usually gives a higher frame rate than the non-combined mode since instead of two (8 or 12 bit) values only one (8 or 12 bit) value is read out from the sensor and transported to the PC memory. There is also less processing overhead in the xiAPI library as the data are already merged in the sensor. Since the output data bit depth from the sensor is limited to the set ADC bit depth, the data is compressed in the sensor using a piecewise linear function.

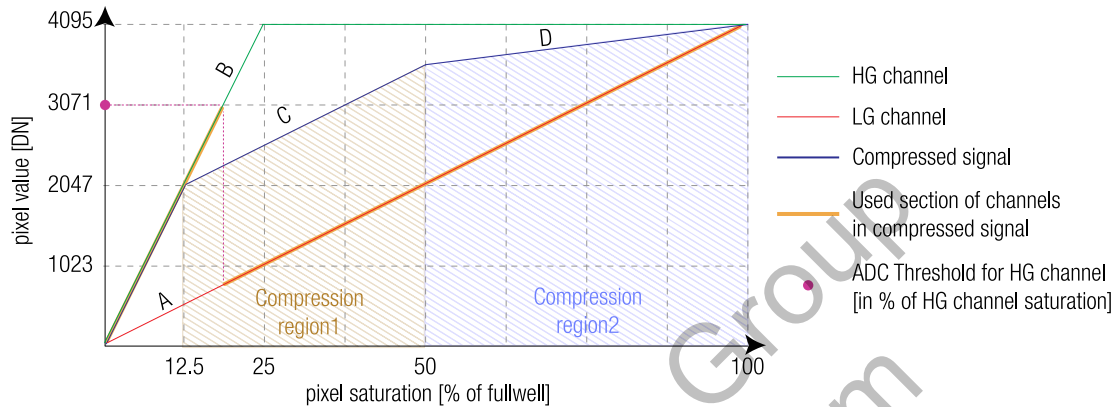

Figure 60: Dual ADC mode combined

The threshold of the usable range of the HG channel can be set using the dual ADC threshold parameter.

```
// define the upper threshold of the usable HG data
xiSetParamInt(xiH, XI_PRM_DUAL_ADC_THRESHOLD,3071);
```

The starting point of the region is defined as a percentage of the maximum ADC output (can be also interpreted as a percentage of full well capacity at the given analog gain setting). It has a logarithmic increment and can have values of 50,25,12.5 ... percent. The slope of the corresponding linear segment is defined as offset from the gain of the HG channel. The above diagram corresponds to the below settings:

```
// Slope B was defined earlier by setting ADC gain ratio to 12 dB
// Set up the start and gain (Slope C) of compression region 1
xiSetParamInt(xiH, XI_PRM_COMPRESSION_REGION_SELECTOR,1);
xiSetParamFloat(xiH, XI_PRM_COMPRESSION_REGION_START,12.5);
xiSetParamFloat(xiH, XI_PRM_COMPRESSION_REGION_GAIN,-12);

// Set up the start and gain (Slope D) of compression region 2
xiSetParamInt(xiH, XI_PRM_COMPRESSION_REGION_SELECTOR,2);
xiSetParamFloat(xiH, XI_PRM_COMPRESSION_REGION_START,50);
xiSetParamFloat(xiH, XI_PRM_COMPRESSION_REGION_GAIN,-24);
```

3.5.2 Non-combined mode

Following camera models support Non-combined mode:
all models in this manual (refer to the table [Models and sensors overview](#))

In the non-combined mode both images are read out from the sensor and are transported to the host PC memory. Depending on the used image data format, these images can be either passed directly to the application or can be merged into a single linear output with extended dynamic range. The merging is performed in the xiAPI library running on the host computer CPU and is optimized for processors with x86 architecture.

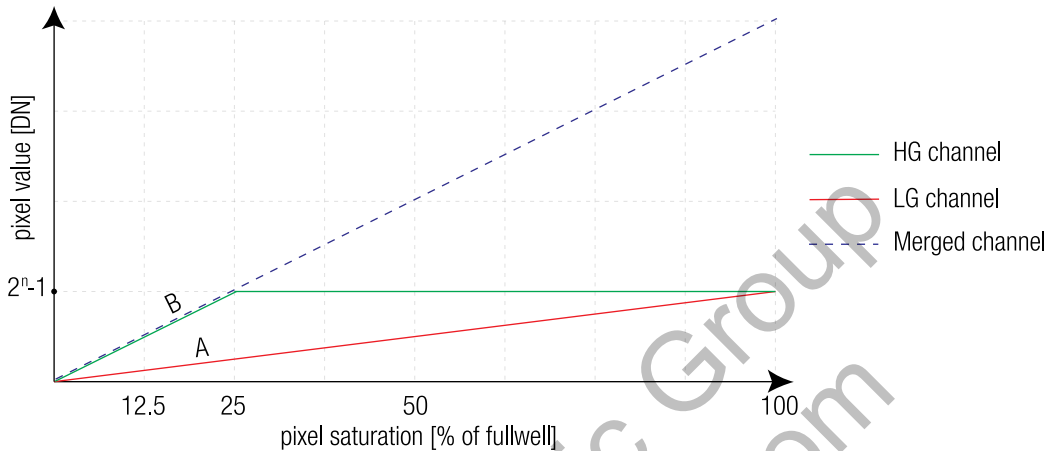

Figure 61: Dual ADC mode non-combined with merging

In case of RAW8X2, RAW16X2 or TRANSPORT_DATA image data format, for each pixel a sequence of LG and the HG channel values are passed to the application ([pixel 0 LG val, pixel 0 HG val, pixel 1 LG val, pixel 1 HG val, ...])

```
// Use X2 or transport format to deliver values from HG and LG channels
xiSetParamInt(xiH, XI_PRM_IMAGE_DATA_FORMAT, XI_RAW16X2);
// Set ADC bitdepth to desired value
xiSetParamInt(xiH, XI_PRM_SENSOR_DATA_BIT_DEPTH, 12);
// Set image data bitdepth to desired value
xiSetParamInt(xiH, XI_PRM_IMAGE_DATA_BIT_DEPTH, 12);
```

In case of all other image data formats, the data from the LG and HG channels are merged into a single linear output with extended dynamic range.

```
// or use any other formats to other to deliver merged from HG and
xiSetParamInt(xiH, XI_PRM_IMAGE_DATA_FORMAT, XI_RAW16);
// Set ADC bitdepth to desired value
xiSetParamInt(xiH, XI_PRM_SENSOR_DATA_BIT_DEPTH, 12);
// Set image data bitdepth to desired value
xiSetParamInt(xiH, XI_PRM_IMAGE_DATA_BIT_DEPTH, 16);
```

3.6 API Features

Host-assisted image processing features available in xiAPI

3.6.1 Exposure – Auto gain

When AEAG is used, every captured image is evaluated for its mean intensity. Based on the result, the exposure and gain values are modified with the objective to achieve a target intensity level for the following image. Further, the maximum applicable exposure and gain values can be defined. Since both, exposure and gain, have an influence on the intensity, the ratio between those two parameters in their contribution to the algorithm can also be set (exposure priority).

3.6.2 White balance

Only for color models: The white balance can be adjusted with three coefficients kR, kG and kB, one for each color channel. These coefficients can be set individually in order to increase or decrease each channel's contribution and therefore allow the user to control the color tint of the image.

Assisted manual white balance

This feature measures the white balance a single time and sets the white balance coefficient to achieve a mean grey (neutral) tint. The measurement is performed on the central rectangle of the image, with 1/8th of its width and height. The function expects a white sheet of paper exposed to 50% of the intensity values (8 Bit RGB values should be around 128) to be visible.

Auto White Balance

The white balance is measured across the full image for every 4th image that is acquired, and the white balance coefficients are set to achieve a neutral colour tint.

3.6.3 Gamma

Only for color models: As a part of the color filtering process, it is possible to adjust the gamma level of the image. The adjustment can be set separately for the luminosity and the chromaticity.

3.6.4 Sharpness

Only for color models: As a part of the color filtering process, it is possible to adjust the sharpness of the image.

3.6.5 Color correction matrix

The color correction matrix is a 4x4-matrix which is applied on each pixel of an image in a host-assisted post-processing step. This Matrix can be used for example to adjust the brightness, contrast, and saturation.

3.6.6 Sensor defect correction

During the manufacturing process, every camera is tested for various type of defects and a list of the measured defect pixels is created and stored in the camera's non-volatile memory. This list is then used for the correction of acquired images during operation. The correction is inactive by default, but can be turned on by the user if a non-processed output is required.

3.6.7 Flat field correction

Flat field correction (FFC or shading correction) is a method to remove non-uniformities in the image caused by different sensitivities of the pixels and by distortions caused by optics. For XIMEA cameras this correction is applied in the image processing part of the [image data flow diagram](#) (it is performed on the host computer thus depending on the image size and CPU performance enabling it may cause increased processing time).

In order for the xiapi to calculate the gain and offset coefficients for each individual pixel, it is necessary to load calibration images (1 dark image and 1 mid-saturated image) before applying FFC in RAW8 or RAW16 format depending on desired output bit depth. To obtain optimal results, camera should be in the same setup (lens, device output bit depth, gain, ROI, downsampling, Zero ROT, light conditions...) during acquisition of calibration images and while using FFC.

Compare of camera output with shading (left) and after FFC enabled (right):

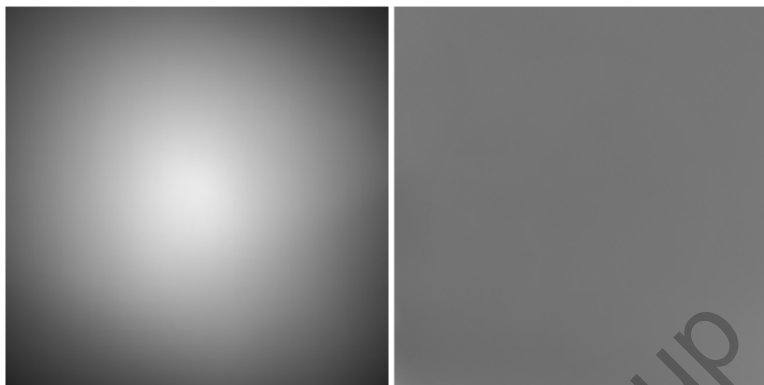

Figure 62: Flat field correction - images comparison

Acquisition of calibration images

The easiest way to acquire calibration images is by using CamTool guide:



Figure 63: Flat field correction - new FFC

Dark Image

Close camera lens with a cap (make it dark) and click button Capture. Average the image from set number of frames to suppress dynamic noise.

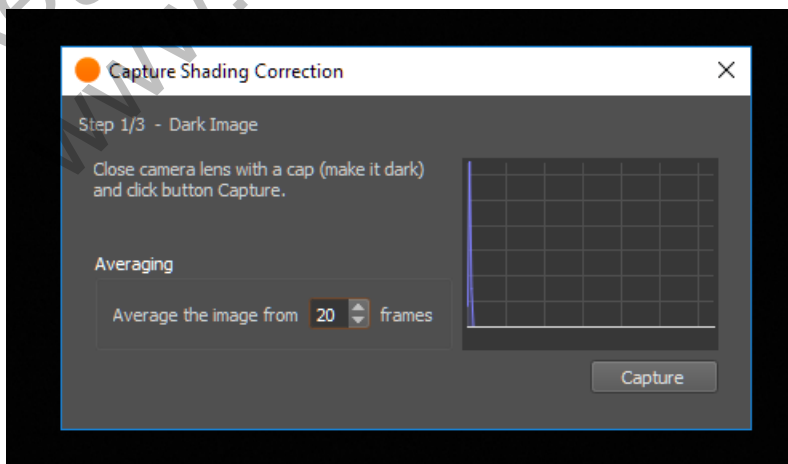

Figure 64: Flat field correction - Dark image

Mid-saturated image

Open camera lens and aim the camera into paper illuminated at 30-70% and click button Capture. Average the image from set number of frames. Image should be focused out of captured plane to reduce dust or other details in the scene.

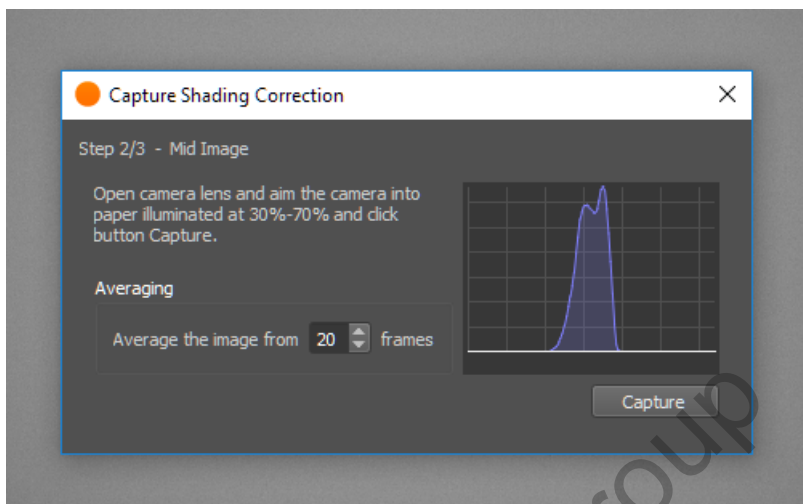

Figure 65: Flat field correction - Mid- saturated image

Save TIFF files

Save the new preset how it be displayed in CamTool.

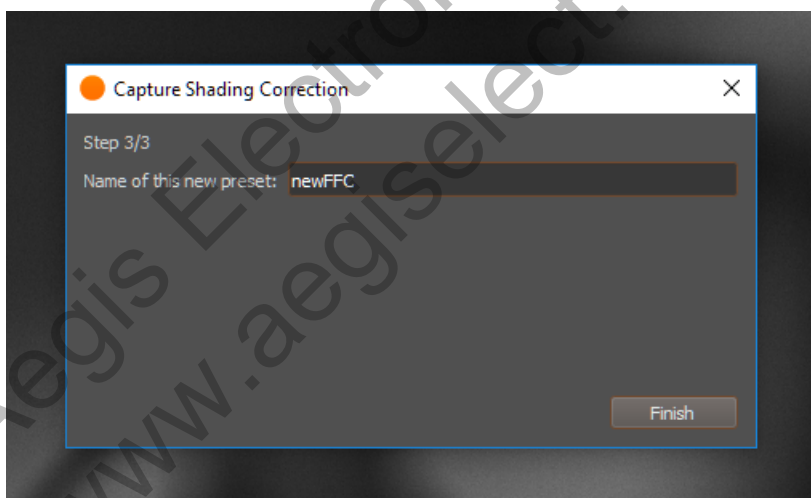

Figure 66: Flat field correction - new preset

To verify calibration, FFC can be also enabled in CamTool by clicking on created preset

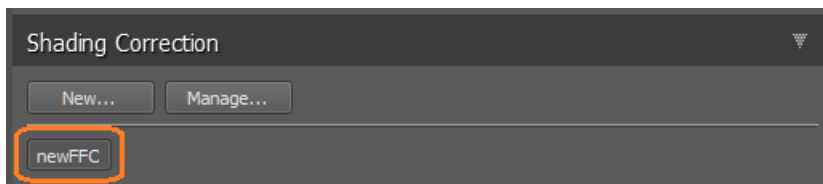

Figure 67: Flat field correction - Enabling FFC

In case of any issue, please double check that all dependent camera parameters (device output bit depth, ROI, downsampling, Zero ROT, exposure, gain...) are in the same setup as during acquisition of calibration images

To see calibration images and be able to save them, click on Manage, then choose preset from list. Camera parameters for that particular preset will be displayed. Click on show dark/mid image

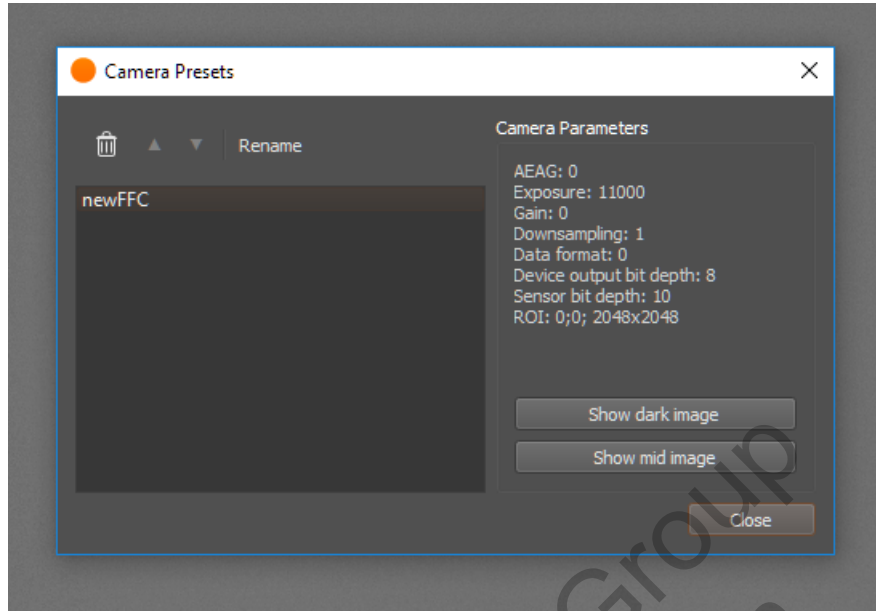

Figure 68: Flat field correction - FFC management

When images are shown in CamTool it is possible to save them by clicking on save icon in top toolbar. Images should be saved in uncompressed TIFF format to use in API.

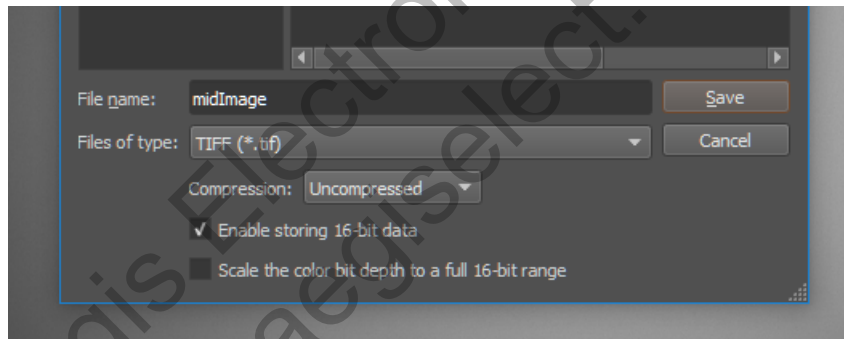

Figure 69: Flat field correction - Safe TIFF

Otherwise, calibration images from CamTool are stored in hidden AppData folder. It can be opened in Windows Run application by command: `%LOCALAPPDATA%\xiCamTool\shading`

Calibration images might be also acquired in any other tool as long as the output is in TIFF format and with the same camera setup.

Applying FFC in xiAPI

xiAPI command sequence:

- Set all dependent camera parameters (device output bit depth, ROI, downsampling, Zero ROT, exposure, gain...) to be in the same setup as during acquisition of calibration images.
- Load dark image - `XI_PRM_FFC_DARK_FIELD_FILE_NAME`
`size` - size of the file name - `strlen(file_name)`.
- Load mid-saturated image - `XI_PRM_FFC_FLAT_FIELD_FILE_NAME`
`size` - size of the file name - `strlen(file_name)` (place both image files into project folder).

Note: Use the same image file for this parameter as for `XI_PRM_FFC_DARK_FIELD_FILE_NAME` for dark-field correction only. Processing will subtract the dark image only while using the unity (1.00) gain for correction.

- Enable `XI_PRM_FFC`.

Sample code:

```
xiSetParamInt(0, XI_PRM_NEW_PROCESS_CHAIN_ENABLE, XI_ON); // MU,MQ,MD camera families
```

```
xiOpenDevice(0, &xiH);  
// set dependent camera params to same values as during calibration
```

```
xiSetParamString(xiH, XI_PRM_FFC_DARK_FIELD_FILE_NAME, "darkImage.tif", strlen("darkImage.tif"));  
xiSetParamString(xiH, XI_PRM_FFC_FLAT_FIELD_FILE_NAME, "midImage.tif", strlen("midImage.tif"));  
xiSetParamInt(xiH, XI_PRM_FFC, 1);
```

In `FFCdemoWithOpenCV.cpp` is FFC demonstrated in OpenCV+xiAPI example. FFC might be enabled or disabled by pressing any key while program is running.

Aegis Electronic Group
www.aegiselect.com

4 Operation

For a proper operation of your camera there are certain requirements that have to be met. You can read more about these requirements as well as about the correct usage of camera in the following sections.

4.1 System requirements

4.1.1 Software requirements

Cameras are compatible with the following operating systems:

- Windows 10, 11
- Linux Ubuntu
- MacOS 10.8 or newer



All XIMEA cameras are compatible with the most advanced Vision and Image Processing Libraries. See chapter [XIMEA Software Packages](#) for more information about the options to access cameras, as well as a list of currently supported libraries and frameworks supported in Windows. For more information visit [API - Application Programming Interfaces](#).

4.1.2 Hardware requirements

The XIMEA cameras are compatible with PCI express Generation 2 & 3. Please note details and the most recent info at: [PCI Express cameras](#).

4.2 XIMEA software packages

4.2.1 XIMEA Windows software package

XIMEA API Software Package can be installed on: Microsoft Windows 10, 11.

Contents

The package contains:

- OS Drivers of all XIMEA camera types for OS Microsoft Windows, Windows Server 2008 R2 x86-64, Windows 10 32/64 bit
- APIs (*xiAPI*, *xiAPI.NET*, *xiApiPython*)
- Examples
- CamTool
- xiCOP
- GenTL Producer - for connection of GenTL Consumer applications
- *Vision Libraries* integration demonstrations:
 - NI LabView interface - xiLib

Installation

- Download and execute the XIMEA API Software Package installer (EXE-file, approximate size 100 MB): http://www.ximea.com/downloads/recent/XIMEA_Installer.exe
- Read the License Agreement
- Start the installer

Be sure that you have administrator privileges or start the Installer with administrator rights (right click and select “run as administrator”):

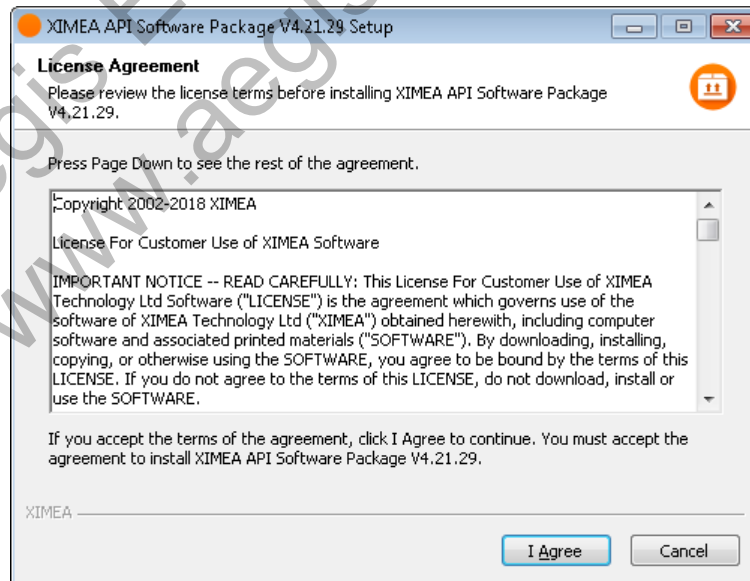

- Select the Software components you want to install. You can uncheck the components you don't want to install, but it is recommended to leave them all checked

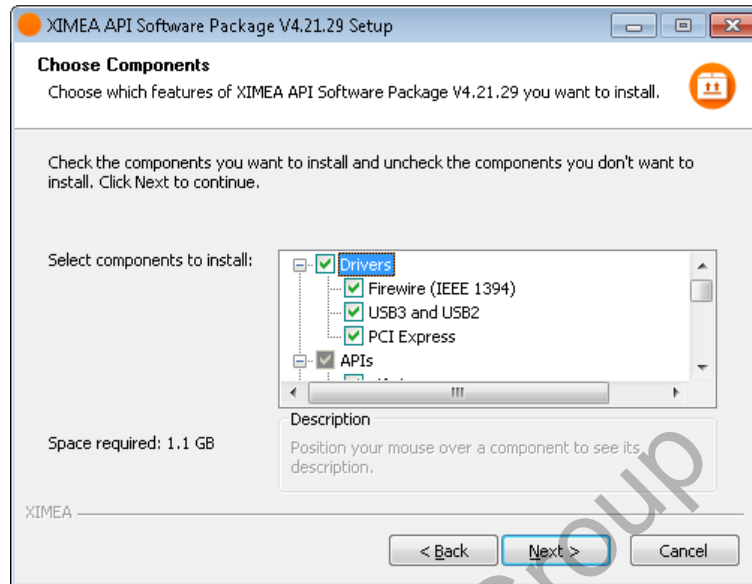

- Specify the install location - you can leave the default location or change it to your desired location

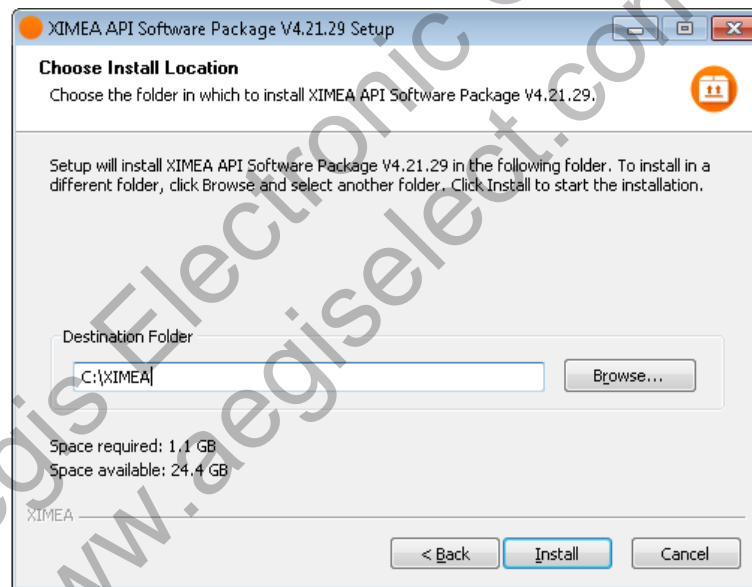

- Now the XIMEA API Software Package should start copying files, updating System Variables and installing drivers if necessary

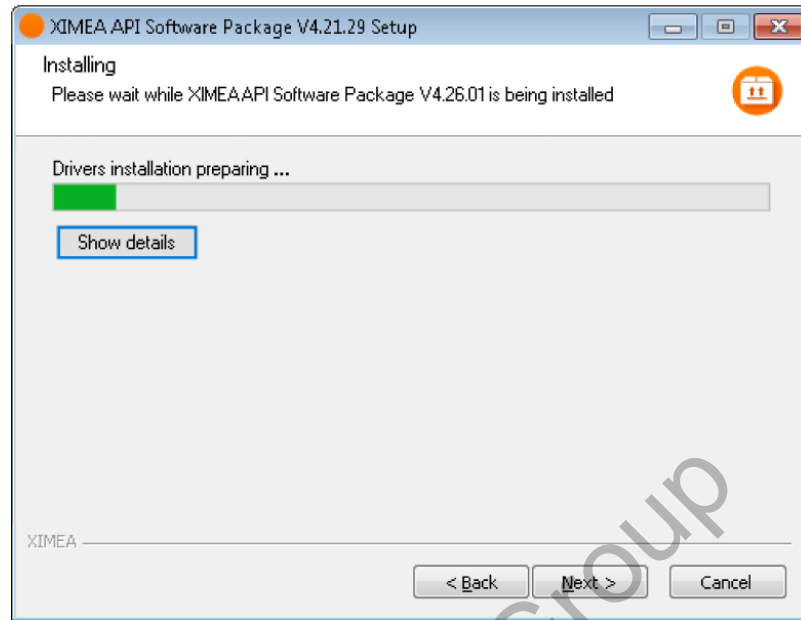

- Installation is completed
- Finish

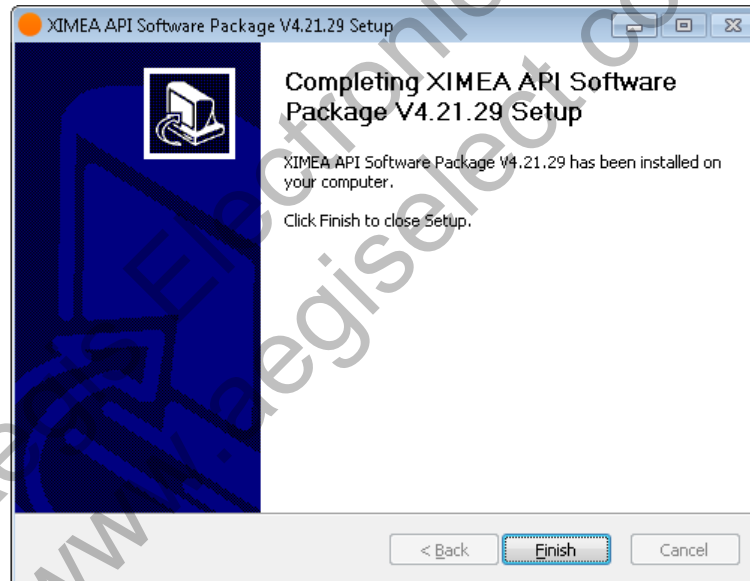

4.2.2 XIMEA Linux software package

XIMEA Linux Software Package is tarred installer with files that can be run on Linux Ubuntu 14.04 and 16.04 (32 and 64 Bit) and newer releases.

Contents

The package contains:

- Driver for XIMEA USB2 and USB3 cameras
- xiAPI
- XIMEA CamTool
- Examples:
 - xiSample - sample showing basic image acquisition in xiAPI

Installation

- Download XIMEA Linux Software Package:

http://www.ximea.com/downloads/recent/XIMEA_Linux_SP.tgz

```
wget http://www.ximea.com/downloads/recent/XIMEA_Linux_SP.tgz
```



```
ximea@ximea-Linux64: ~
ximea@ximea-Linux64:~$ wget http://www.ximea.com/downloads/recent/XIMEA_Linux_SP.tgz
--2013-06-05 17:06:29-- http://www.ximea.com/downloads/recent/XIMEA_Linux_SP.tgz
Resolving www.ximea.com (www.ximea.com)... 91.143.80.251
Connecting to www.ximea.com (www.ximea.com)[91.143.80.251]:80... connected.
HTTP request sent, awaiting response... 301 Moved Permanently
Location: http://www.ximea.com/support/attachments/271/XIMEA_Linux_SP.tgz [following]
--2013-06-05 17:06:30-- http://www.ximea.com/support/attachments/271/XIMEA_Linux_SP.tgz
Connecting to www.ximea.com (www.ximea.com)[91.143.80.251]:80... connected.
HTTP request sent, awaiting response... 200 OK
Length: 3885021 (3.7M) [application/octet-stream]
Saving to: 'XIMEA_Linux_SP.tgz'

100%[=====] 3,885,021 2.09M/s in 1.8s

2013-06-05 17:06:31 (2.09 MB/s) - 'XIMEA_Linux_SP.tgz' saved [3885021/3885021]

ximea@ximea-Linux64:~$
```

- Untar

```
tar xzf XIMEA_Linux_SP.tgz
cd package
```

- Start installation script
`./install`

```
ximea@ximea-Linux64: ~/package
ximea@ximea-Linux64:~$ tar xzf XIMEA_Linux_SP.tgz
ximea@ximea-Linux64:~$ cd package
ximea@ximea-Linux64:~/package$ ./install -cam_usb30
This will install XIMEA Linux Package after 5 seconds
To abort installation - press Ctrl-C
Installing x64 bit version
[sudo] password for ximea:
This is installation of package for platform -x64
Checking if user is super user
OK
-----
WARNING!!!
You have enabled experimental USB3 support! It may affect USB2 support too.
DO NOT downgrade the kernel to versions older than 3.4!!!
Advised way of enabling USB3 support is upgrading kernel to version at least as new as 3.6.
If you decide to do it in the future, rerun this installation script after booting into new k
rnel.
-----
Installing libusb
OK
Installing Firewire support -- libraw1394
OK
Checking Firewire stack
Installing API library
OK
OK
OK
Rebuilding linker cache
Installing XIMEA-GenTL library
OK
Installing vaViewer
OK
Installing streamViewer
OK
Installing xiSample
OK
Creating desktop link for vaViewer
Creating desktop link for streamViewer
Installing udev rules for USB and Firewire cameras
OK
-----
Note:
You may need to reconnect your USB and/or Firewire cameras
Also check that you are in the "plugdev" group
-----
More info:
http://www.ximea.com/support/wiki/apis/Linux_USB20_Support
-----
For GenCam - please add GENICAM_GENTL64_PATH=/opt/XIMEA/lib/libXIMEA_GenTL.so to Your .bashrc
o enable GenTL
Now applications can be started. E.g. /opt/XIMEA/bin/xiSample
-----
Done OK
ximea@ximea-Linux64:~/package$
```

Note: If logged in user is not root, you will be asked for your password to get root access, because the installation runs with root account using sudo.

Aegis Electronics Group
www.aegiselectronics.com

4.2.3 XIMEA macOS software package

XIMEA macOS Software Package is native DMG installer that can be run on macOS 10.8 (Mountain Lion) or newer.

Contents

The package contains:

- Driver (beta version) for XIMEA USB2 and USB3 cameras
- xiAPI
- XIMEA CamTool
- Examples:
 - xiSample - sample showing basic image acquisition in xiAPI

Installation

Before installing XIMEA macOS Software Package it may be necessary to modify security settings on your computer. The new feature of OS X 10.8 called GateKeeper can prevent you from using our macOS Software Package due to the fact that the current version is unsigned.

- Open System Preferences application and click on Security & Privacy

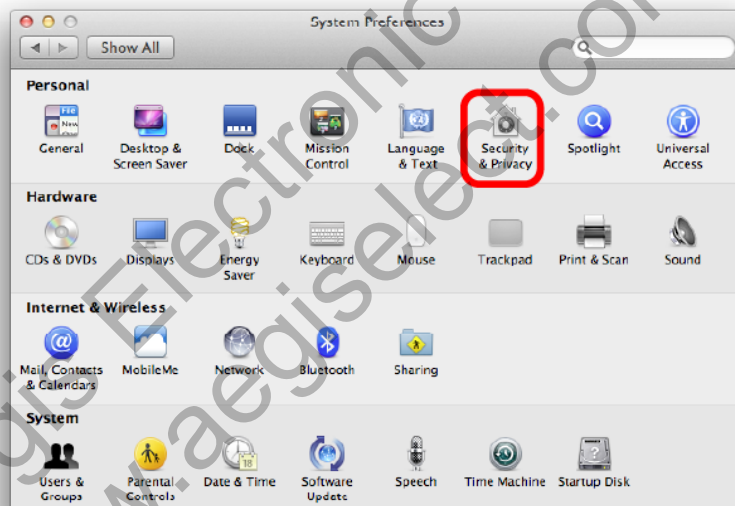

- Click on the lock to allow changes to be made

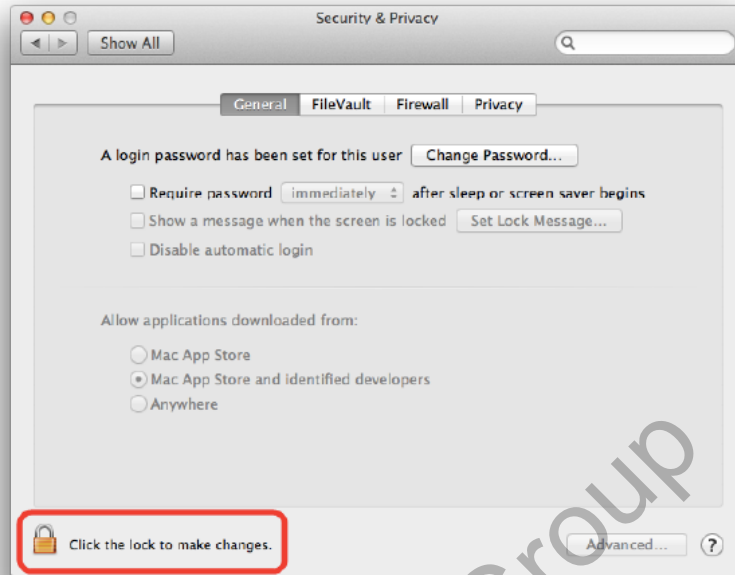

- On the General Tab select the option Anywhere under Allow applications downloaded from:

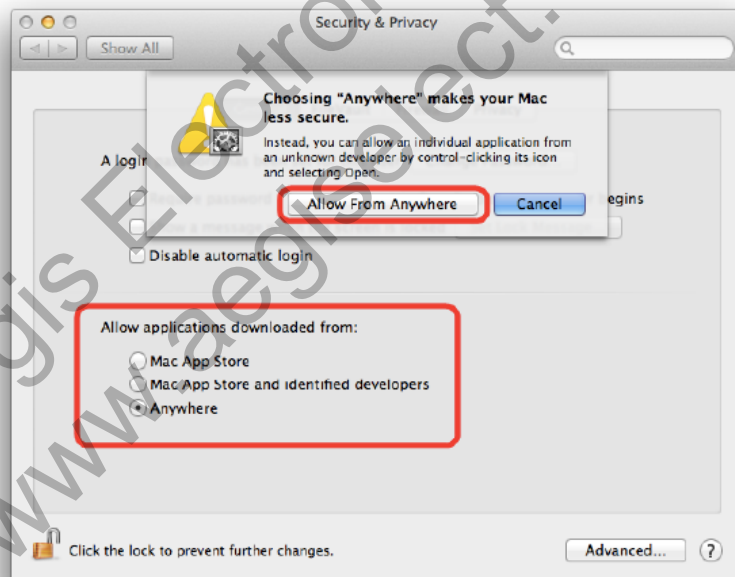

- Download XIMEA macOS Software:
http://www.ximea.com/downloads/recent/XIMEA_OSX_SP.dmg
- Mount it by double-clicking this file in Finder
- Run the install script to install XiAPI on your macOS system
- A window with package contents will open

Start XIMEA CamTool

- Connect camera
- Start Applications / XIMEA CamTool
- Start acquisition by clicking on orange triangle at upper left corner of CamTool



Short description

The CamTool is a cross-platform application showcasing the features of all XIMEA camera families. It runs on Windows, Linux, macOS systems offering a substantial imaging tool set, which can be further extended with custom modules using a plugin infrastructure. CamTool is based on Qt for the UI and xiAPI for the camera control. Its camera settings menu resembles the parameter set of the xiAPI.

4.3 XIMEA CamTool

CamTool allows to operate all connected cameras simultaneously. In this case all controls are layered for the cameras. Basic controls are placed as tabs in upper part of the window. Image window can be detached from application if needed. Amount of visible camera controls depend on visibility level which can be set in Edit → Options. For more information, please, visit our website page: [CamTool](#).

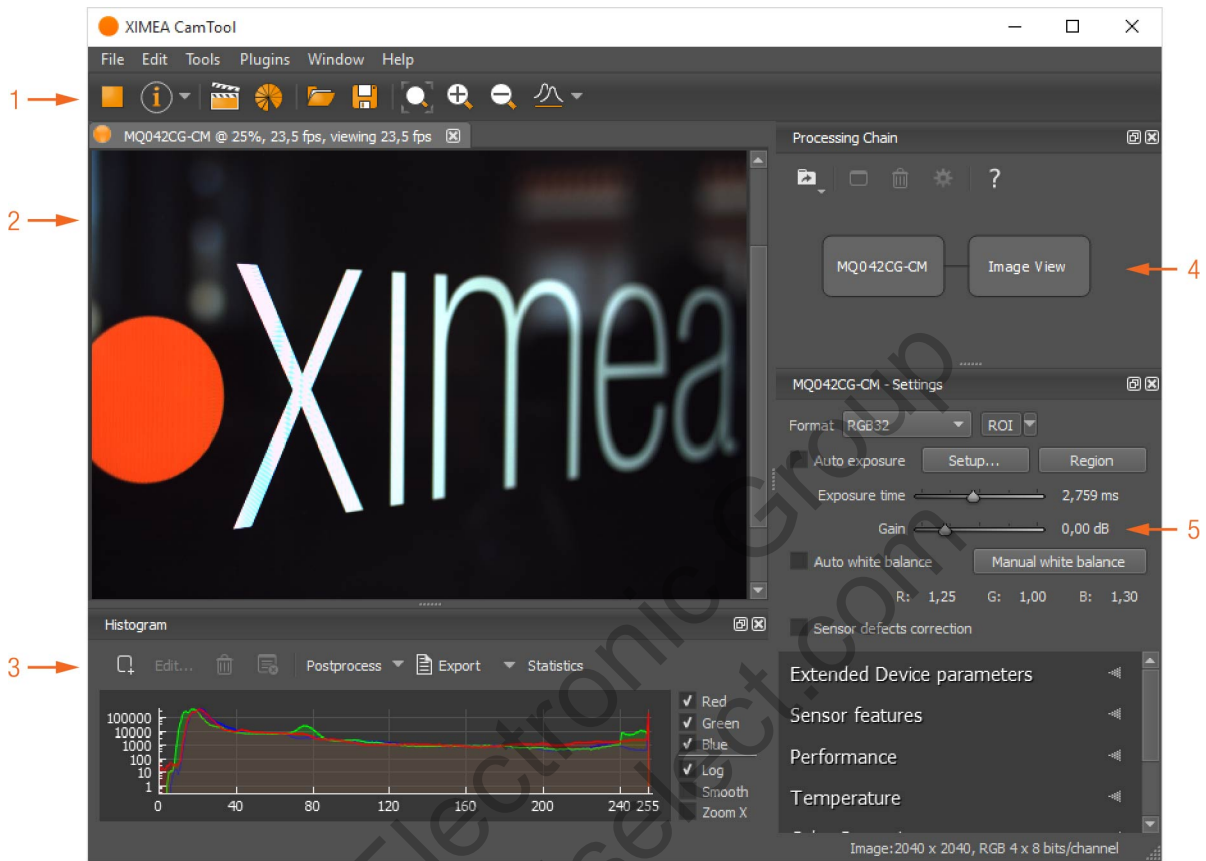

Figure 70: CamTool preview

Number	1	2	3	4	5
Description	Control panel	Image window	Analytics tools	Processing chain	Camera control

Table 42: CamTool layout

Functions

- To see live image from multiple XIMEA cameras connected
- Control the camera parameters
- Store of camera image and video
- Analyze the image properties
- Histogram and line profile
- Image averaging, image flip/mirror
- Software trigger timer, save/load camera and program settings
- LUT (Look up table)
- Lua scripting

4.4 XIMEA control panel

The XIMEA Control Panel (xiCOP), is a diagnostics and management tool for all XIMEA cameras. xiCOP is available for Windows (32, 64-bit) and Linux (64-bit) operating system.

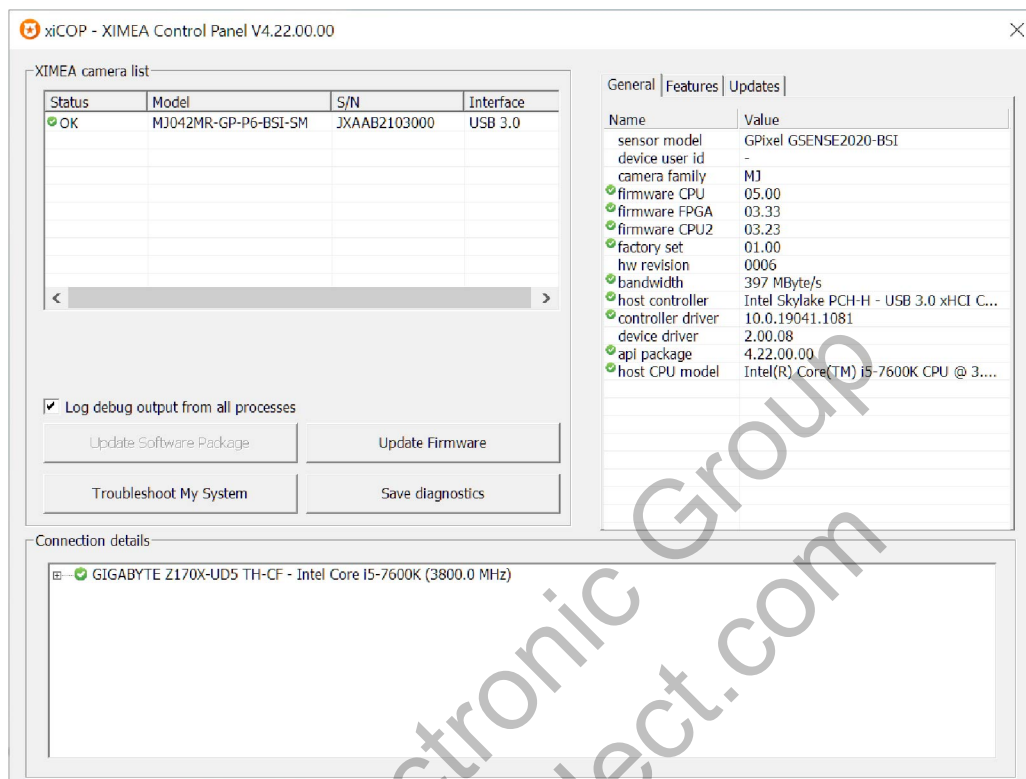

Figure 71: xiCOP example

Features

- Facilitates diagnostics of system performance bottlenecks
xiCOP is capable of retrieving the system's hardware tree, thus problematic hardware configurations can be identified
- Diagnosis of firmware and software compatibility
xiCOP checks relevant firmware and software versions and warns if a component is not up-to-date
- Lists all currently attached XIMEA devices and their features.
- Saves a diagnostic log and debug output which can be reviewed by technical support
- Suggests solution for diagnosed issues
- Allows setting of User IDs to XIMEA cameras
- One click to switch selected XIMEA cameras to USB3 Vision standard and back to XIMEA API
- One click update to the latest XIMEA API Software Package
- One click update of firmware in selected cameras

4.5 Supported vision libraries

All XIMEA cameras are compatible with the most advanced vision and image processing libraries. For GUI based software packages, the cameras can be directly accessed without the need of programming. Code libraries are generally used in conjunction with one of our APIs, in order to add additional functionality (e.g. image processing, communication, data storage).

For an up-to-date listing of the supported vision libraries and software packages, visit our website page: [Vision Libraries](#).

4.5.1 MathWorks MATLAB



MathWorks® is the leading developer and supplier of software for technical computing and Model-Based Design. More on our website page: [MathWorks MATLAB](#).

4.5.2 MVTec HALCON



HALCON is the comprehensive standard software for machine vision with an integrated development environment (IDE) that is used world-wide. More on our website page: [MVTec HALCON](#).

4.5.3 National Instruments LabVIEW vision library



LabVIEW is a graphical programming environment. More on our website page: [National Instruments LabVIEW Vision Library](#).

4.5.4 OpenCV



OpenCV is an open-source library of programming functions mainly aimed at real time computer vision. More on our website page: [OpenCV](#)

4.6 Programming

Depending on the target application, the user can choose between several ways of accessing and controlling the camera. These can be divided into two categories: a programmatic approach, through programming code, or an integrated approach, through a supported, GUI based software package. The programmatic approach is generally used for the development of a custom application or image processing pipeline. The integrated approach is favored, if the specific toolset of a certain software package is sufficient and the camera serves as an integrated capture device.

4.6.1 Standard interface

As an alternative to the proprietary API, the camera can be accessed through a set of standard interfaces. These interfaces decouple a specific hardware design (e.g. physical interface) of a camera from its control in software. Therefore, multiple camera classes and types can be used in a unified way.

GenICam/GenTL

GenICam/GenTL provides a camera-agnostic transport layer interface to acquire images or other data and to communicate with a device. Each camera serves as a GenTL Producer which can be accessed in all software packages that are compatible with the GenICam standard, as well as through custom developments which implement this standard interface. For more information on programming according the GenICam standard, please visit the standard's website at www.emva.org.

4.6.2 xiAPI

xiAPI stands for XIMEA Application Programming Interface. It is a common interface for all XIMEA cameras.

Architecture

API is a software interface between the camera system driver and application.

- On Windows: xiAPI is compiled into xiapi32.dll or xiapi64.dll
- On Linux: xiAPI is compiled into /usr/lib/libm3api.so

Installation

xiAPI is part of all current XIMEA software packages for Windows, Linux and MacOS. For information on the software packages, see [XIMEA Software Packages](#).

xiAPI functions description

The core of xiAPI consists of the following functions, which allow controlling of the camera functionality.

```
// get the number of discovered devices.
XI_RETURN xiGetNumberDevices(OUT DWORD *pNumberDevices);

// open interface
XI_RETURN xiOpenDevice(IN DWORD DevId, OUT PHANDLE hDevice);

// get parameter
XI_RETURN xiGetParam(IN HANDLE hDevice, const char* prm, void* val,
    DWORD * size, XI_PRM_TYPE * type);

// set parameter
XI_RETURN xiSetParam(IN HANDLE hDevice, const char* prm, void* val,
    DWORD size, XI_PRM_TYPE type);
```

```
// start the data acquisition
XI_RETURN xiStartAcquisition(IN HANDLE hDevice);

// acquire image and return image information
XI_RETURN xiGetImage(IN HANDLE hDevice, IN DWORD TimeOut, INOUT XI_IMG * img);

// stop the data acquisition
XI_RETURN xiStopAcquisition(IN HANDLE hDevice);

// close interface
XI_RETURN xiCloseDevice(IN HANDLE hDevice);
```

xiAPI parameters description

For a complete list of available parameters, please visit the xiAPI online manual at [xiAPI Manual](#). All functions in xiAPI return status values in form of the XI_RETURN structure which is defined in xiApi.h. If a parameter is not supported by a certain camera, the return value will represent a respective error code (e.g. 106 - Parameter not supported).

Note: Since xiAPI is a unified programming interface for all of XIMEA's cameras, not all of the described parameters apply for every camera and sensor model.

xiAPI examples

Connect device

This example shows the enumeration of available devices. If any device was found the first device (with index 0) is opened.

```
HANDLE xiH = NULL;

// Get number of camera devices
DWORD dwNumberOfDevices = 0;
xiGetNumberDevices(&dwNumberOfDevices);

if (!dwNumberOfDevices)
{
    printf("No camera found\n");
}
else
{
    // Retrieving a handle to the camera device
    xiOpenDevice(0, &xiH);
}
```

Parameterize device

This example shows how an exposure time is set. Next, the maximum possible downsampling rate is retrieved and the result is set as new downsampling rate.

```
// Setting "exposure" parameter (10ms)
int time_us = 10000;
xiSetParam(xiH, XI_PRM_EXPOSURE, &time_us, sizeof(time_us), xiTypeInteger);

// Getting maximum possible downsampling rate
int dspl_max = 1;
xiGetParamInt(xiH, XI_PRM_DOWNSAMPLING XI_PRM_INFO_MAX, &dspl_max);

// Setting maximum possible downsampling rate
xiSetParamInt(xiH, XI_PRM_DOWNSAMPLING, dspl_max);
```

Acquire images

This example shows how the acquisition is started on the device with the handle xiH, ten images are acquired in a row and the acquisition is stopped.

```

xiStartAcquisition(xiH);

#define EXPECTED_IMAGES 10
for (int images=0;images < EXPECTED_IMAGES;images++)
{
// getting image from camera
xiGetImage(xiH, 5000, &image);
printf("Image %d (%dx%d) received from camera\n", images,
(int)image.width, (int)image.height);
}
xiStopAcquisition(xiH);

```

Hardware trigger and exposure active output

In this setup each image is triggered by a Digital Input Trigger. After the image is triggered, it can be transferred using xiGetImage. This setup ensures a low latency between the trigger signal and image Exposure start.

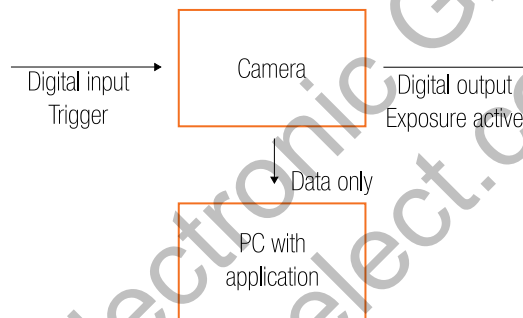

Figure 72: GPIO scheme

```

HANDLE xiH;
xiOpenDevice(0, & xiH);

// select trigger source
xiSetParamInt(xiH, XI_PRM_TRG_SOURCE, XI_TRG_EDGE_RISING);

// select input pin 1 mode
xiSetParamInt(xiH, XI_PRM_GPI_SELECTOR, 1);
xiSetParamInt(xiH, XI_PRM_GPI_MODE, XI_GPI_TRIGGER)

// set digital output 1 mode
xiSetParamInt(xiH, XI_PRM_GPO_SELECTOR, 1);
xiSetParamInt(xiH, XI_PRM_GPO_MODE, XI_GPO_EXPOSURE_ACTIVE);

xiStartAcquisition(handle1);

// Trigger signal should start image exposure within timeout
#define TIMEOUT_IMAGE_WAITING_MS 10000
xiGetImage(handle, TIMEOUT_IMAGE_WAITING_MS, &image);
// process image here...

```

xiAPI Auto Bandwidth Calculation

xiAPI uses Auto Bandwidth Calculation (ABC) before the opening of each camera by default. After the measurement, 90% of the measured value is used as the maximum allowed transfer speed of the camera to ensure the stability of transfer.

It is important to set this parameter to XI_OFF to ensure highest possible data transfer speed.

To disable ABC, the application should set parameter XI_PRM_AUTO_BANDWIDTH_CALCULATION to XI_OFF before the first xiOpenDevice is used. This setting disabled ABC and the camera stream is not limited.

xiAPI.NET

XIMEA Application Programming Interface for Dot Net - Microsoft Visual C#. **xiAPI.NET** is designed as a wrapper around xiAPI and therefore shares most of its functionality.

xiApiPython

Applications in Python can access XIMEA cameras using **xiApiPython** interface. It is a wrapper around xiAPI, which integrates camera features and capabilities into PYTHON.

Aegis Electronic Group
www.aegiselect.com

5 Appendix

5.1 Troubleshooting and support

This chapter explains how to proceed, if you have issues in bringing your camera to proper operation.

At first, please make sure that you have installed the latest version of the following XIMEA software package, based on your OS:

- [XIMEA Windows Software Package](#)
- [XIMEA Linux Software Package](#)
- [XIMEA macOS Software Package](#)

Please make sure, that you have connected your camera with the appropriate XIMEA cable to an appropriate port. Ensure that the connections are carefully locked. Follow the instructions described in section 4.3 (run the camera with the Ximea CamTool). In case that you still have issues, please read the following chapters.

5.1.1 Worldwide support

We offer worldwide first level support to you by our partners. Please refer to your local dealer if you need technical support for your camera.

5.1.2 Before contacting technical support

There are several steps to take before contacting your local dealer for technical support. In case you cannot display images from your camera, please open the XIMEA xiCOP software (please see section 4.4). It will immediately start searching for connected cameras. Your camera will appear in the XIMEA camera list on the upper left side of the xiCOP window if it is connected properly and your USB interface meets the minimum system requirements described in section 4.1. If the camera does not appear, please proceed with the following steps:

- Step 1** Click on the button “Troubleshoot My System” and follow the instructions that are suggested.
- Step 2** If step 1 does not lead to a positive result, please click the button “Save diagnostics”. Keep the diagnostic file ready for providing it to support.
- Step 3** Contact your local dealer where you bought the camera either by phone or by email for first level support. They will decide if they can help you immediately or if more information is necessary for initiating the next steps.

5.2 Frequently Asked Questions

- [Frequently Asked Questions](#)
- [Knowledge Base](#)

5.3 Product service request (PSR)

If you experienced any unexpected behavior of your camera, please, follow the steps described below:

Step 1 – Contact support

If your camera is not working as expected, please, contact your local dealer for troubleshooting the product and determine the eligibility of a Product Service Request (**Product Service Request (PSR)**). In case you were asked to create a **PSR** by your local contact, please continue to **Step 2**.

NOTE: Your product must be UNDER WARRANTY in order to qualify for a free repair or replacement.

Step 2 – Create product service request (PSR)

- Read the **XIMEA General Terms & Conditions**
- Open the **XIMEA Helpdesk**
- Set field Department to “Service”
- Fill in all fields
- Confirm with the button “Submit”

Step 3 – Wait for **PSR** approval

Our support personnel will verify the **PSR** for validity. If your **PSR** is valid and no further information is required, the **PSR** will be approved within 3 business days. After that you will get a notification email contains the shipping instructions. When you received the **PSR** Approval email – please continue to **Step 4**. In case your **PSR** was rejected – please do not send the product to XIMEA.

Step 4 – Sending the camera to XIMEA

If possible, send the camera back in the original package. If not possible, please pack the camera in a way that it cannot be damaged during shipment and send it back as described in the **PSR** Approval email that you have received.

Step 5 – Waiting for service conclusion

Once we have received the camera, we will send you a notification. The XIMEA Service will then check the status of the camera that you have sent for a possible repair. Depending on warranty conditions, product status and agreement one of the following operations will be performed:

Operation	Repair costs paid by	Return delivery costs paid by
repaired in warranty	XIMEA	XIMEA
replaced in warranty	XIMEA	XIMEA
repaired for cost	Customer	Customer
not repaired and returned	—	Customer
not repaired and discarded if requested by customer	—	—

Table 43: Service operations overview

If the camera will be returned, you will receive the tracking number. In this case, please continue to **Step 6**.

Step 6 – Waiting for return delivery

After you have received the return shipment, please confirm it by changing the status of the **PSR** to “Received by customer”.

NOTE: If you have any problems accessing the links below, please contact our [Support Team](#) at www.ximea.com.

5.4 Safety instructions and precautions

Safety instructions and precautions are available at the following XIMEA webpage: [Safety instructions and precautions](#).

5.5 Warranty

Information about warranty is available at the following XIMEA webpage: [Warranty](#).

5.6 Standard Terms & Conditions of XIMEA GmbH

The Standard Terms and Conditions are available at the following XIMEA webpage: [General Terms and Conditions](#).

5.7 List of Trademarks

List of Trademarks is available at the following XIMEA webpage: [List of Trademarks](#).

5.8 Copyright

All texts, pictures and graphics are protected by copyright and other laws protecting intellectual property. It is not permitted to copy or modify them for trade use or transfer, nor may they be used on websites.

Aegis Electronic Group
www.aegiselect.com

Glossary

- API** Application Programming Interface 62
- CMOS** Complementary Metal-Oxide-Semiconductor 9, 64
- ESD** Electrostatic discharge 32
- FPGA** Field Programmable Gate Array 58
- FPS** Frame Per Second 61
- PSR** Product Service Request 90
- ROI** Region Of Interest 58
- SDK** Software Development Kit 9

Aegis Electronic Group
www.aegiselect.com

List of Figures

1	Standard conformity CE logo	3
2	Standard conformity UKCA logo	3
3	Standard conformity FCC logo	3
4	Standard conformity RoHS logo	4
5	Standard conformity WEEE logo	4
6	Camera with accessory/cooling options	12
7	Lens mount adapter C-mount for xiX-Xtreme camera models	15
8	xiX-Xtreme camera mounting points	16
9	M4 mounting screws	16
10	Cross section of MX161/203/245xG-SY-X4G3-FF camera models	17
11	Filter glass ICR650 Transmission Curve	18
12	Filter glass BK7 AR2x Transmission Curve	19
13	Graph quantum efficiency of Sony IMX532	26
14	Graph quantum efficiency of Sony IMX531	26
15	Graph quantum efficiency of Sony IMX530	27
16	Dimensional drawing of MX161/203/245xR-SY-X4G3-xxx	29
17	Dimensional drawing of MX161/203/245xR-SY-X4G3-xxx with detached sensor sub-assembly	30
18	Position of LEDs on xiX-Xtreme camera	31
19	PCIe / FireFly connector location	32
20	PCIe / FireFly connector pinout	33
21	IO connectors position	35
22	CBL-PB4-PWR-0M15	40
23	CBL-PB6-PT-0M30	40
24	CBL-ECUE-X4G3-1M0	40
25	HQCD cable	41
26	CB-X8G3-FAN-COOLER	42
27	Dimensional drawing of CB-X8G3-FAN-COOLER	42
28	CB-X8G3-WAT-COOLER	43
29	Dimensional drawing of CB-X8G3-WAT-COOLER-KIT	43
30	MECH-60MM-BRACKET-T	45
31	Dimensional drawing of MECH-60MM-BRACKET-T	45
32	MQ-BRACKET-T	46
33	MQ-BRACKET-T dimensional drawing	46
34	MQ-BRACKET-T thick dimensional drawing	46
35	ADPT-MX-X4G3-FF-X4G3-MTP dimensional drawing	47
36	ADPT-MX-X4G3-FF-X4G3-MTP IO connector	48
37	Dimensional drawing MX161 203 245xG-SY-X4G3-xxx	49
38	Dimensional drawing MX161 203 245xG-SY-X4G3-xxx-MTP-WATERCOOLED	49
39	CBL-MT-PWR-SYNC-3M0 drawing	50
40	Wiring diagram of the CBL-MT-POWER-SYNC-3M0	50
41	ADPT-MX-X4G3-FF-X4G3-SFF	51
42	ADPT-MX-X4G3-FF-X4G3-SFF dimensional drawing	51
43	ADPT-MX-X4G3-FF-X4G3-SFF IO connector	52
44	Dimensional drawing MX161 203 245xG-SY-X4G3-xxx-SFF-AIRCOOLED	53
45	Dimensional drawing MX161 203 245xG-SY-X4G3-xxx-SFF-WATERCOOLED	53
46	FireFly to MTP adapters	54
47	ADPT-1P-X4G3-FF-X4G3-MTP dimensional drawings	54
48	ADPT-1P-X8G3-FF-X8G3-MTP and ADPT-2P-X2G3-FF-X4G3-MTP dimensional drawings	55
49	ADPT-4P-X2G3-FF-X8G3-MTP dimensional drawings	55
50	PCIe host adapters	56
51	Dimensional drawing of host adapter HA-1P-X4G3-MTP-X8G3	56
52	Dimensional drawing of host adapter HA-2P-X4G3-MTP-X8G3	57
53	Dimensional drawing of host adapter HA-2P-X4G3-FF-X8G3	57
54	Acquisition mode - free run	61
55	Triggered burst of frames – frame burst start	62
56	Triggered burst of frames – frame burst active	62

57	Exposure defined by trigger pulse length	62
58	Short interval shutter mode – triggered	63
59	Dual ADC mode non-combined with merging	65
60	Dual ADC mode combined	66
61	Dual ADC mode non-combined with merging	67
62	Flat field correction - images comparison	69
63	Flat field correction - new FFC	69
64	Flat field correction - Dark image	69
65	Flat field correction - Mid- saturated image	70
66	Flat field correction - new preset	70
67	Flat field correction - Enabling FFC	70
68	Flat field correction - FFC management	71
69	Flat field correction - Safe TIFF	71
70	CamTool preview	82
71	xiCOP example	83
72	GPIO scheme	87

Aegis Electronic Group
www.aegiselect.com

List of Tables

1	List of camera models and their respective sensor models and filters	11
2	Accessories overview	12
3	Power consumption of: all models in this manual (refer to the table Models and sensors overview)	13
4	Environment	14
5	M4 screw description	16
6	IR650 filter window parameter	18
7	BK7 filter window parameter	19
8	Sensor parameters of: MX161CG-SY-X4G3-FF and MX161MG-SY-X4G3-FF	20
9	Sensor parameters of: MX203CG-SY-X4G3-FF and MX203MG-SY-X4G3-FF	20
10	Sensor parameters of: MX245CG-SY-X4G3-FF and MX245MG-SY-X4G3-FF	20
11	Image quality parameters of: MX161CG-SY-X4G3-FF and MX161MG-SY-X4G3-FF	21
12	Image quality parameters of: MX203CG-SY-X4G3-FF and MX203MG-SY-X4G3-FF	21
13	Image quality parameters of: MX245CG-SY-X4G3-FF and MX245MG-SY-X4G3-FF	22
14	Sensor read-out modes of: MX161CG-SY-X4G3-FF	23
15	Sensor read-out modes of: MX161MG-SY-X4G3-FF	23
16	Sensor read-out modes of: MX203CG-SY-X4G3-FF	24
17	Sensor read-out modes of: MX203MG-SY-X4G3-FF	24
18	Sensor read-out modes of: MX245CG-SY-X4G3-FF	25
19	Sensor read-out modes of: MX245MG-SY-X4G3-FF	25
20	Camera parameters of: all models in this manual (refer to the table Models and sensors overview)	28
21	LED output during power up of: all models in this manual (refer to the table Models and sensors overview)	31
22	LED statuses during boot sequence of: all models in this manual (refer to the table Models and sensors overview)	31
23	Firefly interface mating connector description	32
24	FireFly UEC8 connector pin assignment	33
25	FireFly UEC5 connector pin assignment	34
26	Firefly connector I/O pin assignment	35
27	GPIO mating connector description	35
28	Power connector pin assignment	35
29	I/O connector pin assignment	36
30	General info for optically isolated digital input	37
31	General info for optically isolated digital output	38
32	General info for non-isolated digital in/out trigger lines	39
33	CBL-PB4-PWR-0M15 description	40
34	CBL-PB6-PT-0M30 description	40
35	Mechanical parameters of CB-X8G3-FAN-COOLER	42
36	Parameters of MECH-60MM-BRACKET-T	45
37	ADPT-MX-X4G3-FF-X4G3-MTP IO pin assignment	48
38	CBL-MT-POWER-SYNC-3M0 pin assignment	50
39	ADPT-MX-X4G3-FF-X4G3-SFF IO pin assignment	52
40	Image data output formats	59
41	Image data output formats	60
42	CamTool layout	82
43	Service operations overview	90

