



xiB xiB-64

[ksi-bee: or sai-bee:]

- PCI Express camera series

Technical Manual

Version 1.09, April 2021

1. Introduction

1.1. About This Manual

Dear customer,

Thank you for purchasing a product from XIMEA.

We hope that this manual can answer your questions, but should you have any further questions or if you wish to claim a service or warranty case, please contact your local dealer or refer to the XIMEA Support on our website:

www.ximea.com/support

The purpose of this document is to provide a description of the XIMEA xiB and xiB64-Series cameras and to describe the correct way to install related software and drivers and run it successfully. Please read this manual thoroughly before operating your new camera for the first time. Please follow all instructions and observe the warnings.

This document is subject to change without notice.

1.2. About XIMEA

XIMEA is one of the worldwide leaders for innovative camera solutions with a 25-year history of research, development and production of digital image acquisition systems. Based in Slovakia, Germany and the US and with a global distributor network, XIMEA offers their cameras worldwide. In close collaboration with customers XIMEA has developed a broad spectrum of technologies and cutting-edge, highly competitive products.

XIMEA's camera centric technology portfolio comprises a broad spectrum of digital technologies, from data interfaces such as USB 2.0, USB 3.1 and PCIe to cooled digital cameras with CCD, CMOS and sCMOS sensors, as well as X-ray cameras.

XIMEA has three divisions – generic machine vision and integrated vision systems, scientific imaging and OEM/custom.

XIMEA cameras find use in many industrial applications, such as motion control, robotics, or quality control in manufacturing.

The broad spectrum of cameras also includes thermally stabilized X-ray cameras, and specialty cameras for medical applications, research, surveillance and defense.

1.2.1. Contact XIMEA

XIMEA is a worldwide operating company

Headquarters
Sales worldwide

XIMEA GmbH
Am Mittelhafen 16
48155 Münster
Germany

Tel: +49 (251) 202 408-0
Fax: +49 (251) 202 408-99

Sales America

XIMEA Corp.
12600 W Colfax Ave., Suite A-130
Lakewood, CO 80215
USA

Tel: +1 (303) 389-9838
Fax: +1 (303) 202-6350

R&D, Production

XIMEA s.r.o.
Lesna 52
900 33 Marianka
Slovakia

Internet	www.ximea.com
General inquiries	info@ximea.com
Sales	sales@ximea.com
Support	https://www.ximea.com/support/wiki/allprod/Contact_Support

1.3. Standard Conformity

The xiB cameras have been tested using the following equipment:

- Camera with lens Canon EF 50mm 1:1.8 and EF lens mount adapter
- IPASS™ PCIe x4 cable, 7m length, MOLEX type 74546-0407 (XIMEA P/N: CBL-PCI-COP-7M0)
- IPASS™ PCIe x4 cable, 3m length, MOLEX type 74546-0403, (XIMEA P/N: CBL-PCI-COP-3M0)
- 10 meter PCIe Gen2 x4, fiber optics cable, Samtec type PCIE-4G2-010.0-11 (XIMEA P/N: CBL-PCI-FIB- 10M0)
- 3 meter xiB series power/sync cable, 12 poles, type A65-3786 (revision 05) (XIMEA P/N: CBL-CBSYNC-3M0)
- Tripod adapter (XIMEA P/N: MECH-60MM-BRACKET-T)
- AC power adapter M+R Multitronik GmbH, Model BACS30M-24V-C8, 24V DC/1.25A (S/N:30240-0000198), (XIMEA P/N: BACS30M-24-C8)

The xiB-64 models have not been certified, yet...

Warning: Changes or modifications to the product may render it ineligible for operation under CE, FCC or other jurisdictions.

XIMEA recommends using the above configuration to ensure compliance with the following standards:

1.3.1. CE Conformity



The xiB cameras described in this manual comply with the requirements of the

- EC EMC Directive 2014/30/EU electromagnetic compatibility of equipment

1.3.2. For customers in the US: FCC Conformity



The xiB cameras described in this manual have been tested and found to comply with Part 15 of the FCC rules, which states that:

Operation is subject to the following two conditions:

- This device may not cause harmful interference, and
- This device must accept any interference received, including interference that may cause undesired operation.

This equipment has been tested and found to comply with the limits for Class A digital device, pursuant to part 15 of the FCC rules. These limits are designed to provide reasonable protection against harmful interference when the equipment is operated in a commercial environment. This equipment generates, uses and can radiate radio frequency energy and, if not installed and used in accordance with the instruction manual, may cause harmful interference to radio communications. Operation of this equipment in a residential area is likely to cause harmful interference in which case the users will be required to correct the interference at their own expense.

You are cautioned that any changes or modifications not expressly approved in this manual could void your authority to operate this equipment under above jurisdictions. The shielded interface cable recommended in this manual must be used with this equipment in order to comply with the limits for a computing device pursuant to Subpart J of Part 15 of FCC Rules.

The xiB-64 models have not been certified, yet.

1.3.3. For customers in Canada

The xiB cameras comply with the Class A limits for radio noise emissions set out in Radio Interference Regulations.

The xiB-64 models have not been certified, yet.

1.3.4. RoHS Conformity



The xiB & xiB-64 cameras comply with the requirements of the RoHS (Restriction of Hazardous Substances) Directive 2011/65/EU.

1.3.5. WEEE Conformity



The xiB and xiB-64 cameras comply with the requirements of the WEEE (waste electrical and electronic equipment) Directive 2012/19/EU.

1.3.6. GenlCam GenTL API

GEN<i>i</i>CAM

GenlCam standard transport layer interface, grabbing images. **GenlCam/GenTL** provides an agnostic transport layer interface to acquire images or other data and to communicate with a device. Each XIMEA camera can be GenTL Producer.

1.4. Helpful Links

- Ximea Homepage <http://www.ximea.com/>
- xiB product page <https://www.ximea.com/en/pci-express-camera/pci-express-camera-cmv12000-cmv20000>
- PCI Express support page https://www.ximea.com/support/wiki/xib/PCI_Express_camera_-_xiB
- Quick start guide https://www.ximea.com/support/wiki/xib/Quick_Start_Guide
- xiAPI stable versions download <https://www.ximea.com/support/documents/4>
- xiAPI beta versions download <https://www.ximea.com/support/documents/14>
- Frequently Asked Questions http://www.ximea.com/support/wiki/allprod/Frequently_Asked_Questions
- Knowledge Base http://www.ximea.com/support/wiki/allprod/Knowledge_Base
- Vision Libraries <http://www.ximea.com/support/projects/vision-libraries/wiki>
- XIMEA Registration <http://www.ximea.com/en/products/register>
- XIMEA Live Support http://www.ximea.com/support/wiki/allprod/XIMEA_Live_Support
- XIMEA General Terms & Conditions <http://www.ximea.com/en/corporate/generaltc>

1.4.1. Table of Contents

1.	Introduction	2
1.1.	About This Manual	2
1.2.	About XIMEA	2
1.2.1.	Contact XIMEA	2
1.3.	Standard Conformity	3
1.3.1.	CE Conformity	3
1.3.2.	For customers in the US: FCC Conformity	3
1.3.3.	For customers in Canada	3
1.3.4.	RoHS Conformity	3
1.3.5.	WEEE Conformity	4
1.3.6.	GenCam GenTL API	4
1.4.	Helpful Links	4
1.4.1.	Table of Contents	5
2.	xiB / xiB-64 Camera Series	10
2.1.	What is xiB / xiB-64	10
2.2.	Advantages	10
2.3.	PCI Express Vision Camera Applications	11
2.4.	Common features	11
2.5.	Model Nomenclature	12
2.6.	Models Overview, sensor and models	13
2.7.	Options	13
2.8.	Accessories	14
3.	Hardware Specification	15
3.1.	Power Supply	15
3.2.	General Specification	15
3.2.1.	Environment	15
3.2.2.	Firmware / Host driver / API features	15
3.3.	Lens Mount	16
3.4.	Mounting points	17
3.5.	Optical path	17
3.6.	Model Specific Characteristics	18
3.6.1.	CB120xG-CM	18
3.6.1.1.	Sensor and camera parameters	18
3.6.1.2.	Quantum efficiency curves [%]	19
3.6.1.3.	Dimensional drawings CB120xG-CM	20
3.6.1.4.	Referenced documents	21
3.6.1.5.	Sensor features	21
3.6.2.	CB200xG-CM	22
3.6.2.1.	Sensor and camera parameters	22
3.6.2.2.	Quantum efficiency curves [%]	23
3.6.2.3.	Dimensional drawings CB200xG-CM	24
3.6.2.4.	Referenced documents	25
3.6.2.5.	Sensor features	25
3.6.3.	CB500xG-CM	26
3.6.3.1.	Sensor and camera parameters	26
3.6.3.2.	Quantum efficiency curves [%]	27
3.6.3.3.	Dimensional drawings CB500xG-CM (with and without EF mount)	28
3.6.3.4.	Referenced documents	29
3.6.3.5.	Sensor features	29
3.6.4.	CB013xG-LX-X8G3	30
3.6.4.1.	Sensor and camera parameters	30

3.6.4.2.	Quantum efficiency curves [%].....	31
3.6.4.3.	Dimensional drawings CB013xG-LX-X8G3.....	32
3.6.4.4.	Referenced documents.....	33
3.6.4.5.	Sensor features	33
3.6.5.	CB019xG-LX-X8G3.....	34
3.6.5.1.	Sensor and camera parameters	34
3.6.5.2.	Quantum efficiency curves [%].....	35
3.6.5.3.	Dimensional drawings CB019xG-LX-X8G3.....	36
3.6.5.4.	Referenced documents.....	37
3.6.5.5.	Sensor features	37
3.6.6.	CB120xG-CM-X8G3.....	38
3.6.6.1.	Sensor and camera parameters	38
3.6.6.2.	Quantum efficiency curves [%].....	39
3.6.6.3.	Dimensional drawings CB120xG-CM-X8G3	40
3.6.6.4.	Referenced documents.....	41
3.6.6.5.	Sensor features	41
3.6.7.	CB160xG-LX-X8G3.....	42
3.6.7.1.	Sensor and camera parameters	42
3.6.7.2.	Quantum efficiency curves [%].....	43
3.6.7.3.	Dimensional drawings CB160xG-LX-X8G3.....	44
3.6.7.4.	Referenced documents.....	44
3.6.7.5.	Sensor features	45
3.6.8.	CB262xG-GP-X8G3	46
3.6.8.1.	Sensor and camera parameters	46
3.6.8.2.	Quantum efficiency curves [%].....	47
3.6.8.3.	Dimensional drawings CB262xG-GP-X8G3	48
3.6.8.4.	Referenced documents.....	48
3.6.8.5.	Sensor features	49
3.6.9.	CB654xG-GP-X8G3	50
3.6.9.1.	Sensor and camera parameters	50
3.6.9.2.	Quantum efficiency curves [%].....	51
3.6.9.3.	Dimensional drawings CB654xG-GP-X8G3	52
3.6.9.4.	Referenced documents.....	52
3.6.9.5.	Sensor features	53
3.7.	User interface – LEDs	54
3.8.	xiB, xiB-64 PCIe Interface.....	55
3.8.1.	iPass™ Connector Location	55
3.9.	Digital Input / Output (GPIO) Interface and Power	56
3.9.1.	Location	56
3.9.2.	IO Connector Pinning	56
3.9.3.	Power input.....	58
3.9.4.	Optically isolated Digital Input	59
3.9.4.1.	Optically isolated Digital Input - General info	59
3.9.4.2.	Digital Input – signal levels	59
3.9.4.3.	Digital Input – Internal Schematic.....	60
3.9.4.4.	Digital Input – Wiring.....	60
3.9.4.5.	Digital Input – Timing	61
3.9.5.	Optically isolated Digital Output.....	61
3.9.5.1.	Optically isolated Digital Output - General info.....	61
3.9.5.2.	Optically isolated Digital Output Delay.....	61
3.9.5.3.	Optically isolated Digital Output – Internal schematic.....	62
3.9.5.4.	Digital Output – Wiring	62

3.9.5.5.	Digital Output – Timing.....	67
3.9.6.	Non-isolated Digital Lines.....	68
3.9.6.1.	Specification for Hardware revision \leq 09.....	68
3.9.6.2.	Specification for Hardware revision $>$ 09.....	69
3.10.	Power supply input (AUX PWR).....	69
3.11.	CBL-PCI-COP-xx/ CBL-PCI-FIB-xx.....	70
3.12.	PCIe host adapter cards.....	71
3.13.	CBL-CB-PWR-SYNC-3M0.....	72
3.14.	CBL-MT-PWR-SYNC-3M0.....	74
3.15.	Tripod Adapter – MECH-60MM-BRACKET-T.....	75
3.16.	xiB-64 cooling – CB-X8G3-FAN-COOLER-KIT.....	76
3.17.	xiB cooling – MECH-60MM-HEATSINK-KIT.....	77
3.18.	xiB Lens adapter – MECH-60MM-EF-ADAPTER.....	78
3.19.	xiB Lens adapter – LA-C-MNT-60MM-xxx-KIT.....	78
4.	Operation.....	79
4.1.	System Requirements.....	79
4.1.1.	Software Requirements.....	79
4.1.2.	Hardware Requirements.....	79
4.1.2.1.	System Configuration.....	79
4.1.2.2.	Cables.....	80
4.2.	Correct system connection and power on sequence.....	80
4.3.	Video Formats.....	81
4.3.1.	Full Resolution.....	81
4.3.2.	ROIs – Region Of Interest.....	81
4.3.3.	Downsampling Modes.....	81
4.3.3.1.	Binning.....	81
4.3.3.2.	Skipping.....	81
4.3.4.	Image Data Output Formats.....	82
4.4.	Acquisition modes.....	83
4.4.1.	Free-Run.....	83
4.4.2.	Trigger controlled Acquisition/Exposure.....	83
4.4.2.1.	Triggered acquisition - single frame.....	84
4.4.2.2.	Triggered acquisition - burst of frames.....	85
4.4.2.3.	Exposure defined by trigger pulse length.....	85
4.5.	Camera Parameters and Features.....	86
4.5.1.	Exposure Time.....	86
4.5.2.	Gain.....	86
4.6.	Host-Assisted Image Processing Parameters Available in xiAPI.....	86
4.6.1.	Auto Exposure – Auto Gain.....	86
4.6.2.	White Balance.....	86
4.6.2.1.	Assisted Manual White Balance.....	86
4.6.2.2.	Auto White Balance.....	86
4.6.3.	Gamma.....	86
4.6.4.	Sharpness.....	86
4.6.5.	Color Correction Matrix.....	87
4.6.6.	Sensor Defect Correction.....	87
4.6.7.	HDR.....	88
5.	Software.....	91
5.1.	Accessing the Camera.....	91
5.1.1.	Proprietary API.....	91
5.1.2.	Standard Interface.....	91
5.1.2.1.	GenICam.....	91

5.1.3.	Vision Library Integration	91
5.2.	XIMEA CamTool	92
5.3.	Supported Vision Libraries	94
5.3.1.	Libraries maintained by XIMEA	94
5.3.1.1.	MathWorks MATLAB	94
5.3.1.2.	MVTec HALCON	94
5.3.1.3.	National Instruments LabVIEW Vision Library	94
5.3.1.4.	OpenCV	94
5.4.	XIMEA Windows Software Package	95
5.4.1.	Contents	95
5.4.2.	Installation	95
5.5.	XIMEA Linux Software Package	98
5.5.1.	Contents	98
5.5.2.	Installation	98
5.6.	XIMEA macOS Software Package	100
5.6.1.	Contents	100
5.6.2.	Installation	100
5.6.3.	Start XIMEA CamTool	101
5.7.	Programming	102
5.7.1.	XIMEA APIs	102
5.7.2.	xiAPI Overview	102
5.7.3.	xiAPI Functions Description	102
5.7.4.	xiAPI Parameters Description	103
5.7.5.	xiAPI Examples	103
5.7.5.1.	Connect Device	103
5.7.5.2.	Parameterize Device	103
5.7.5.3.	Acquire Images	104
5.7.5.4.	Control Digital Input / Output (GPIO)	104
5.7.6.	xiAPI Auto Bandwidth Calculation	104
5.7.7.	GenICam	105
5.8.	XIMEA Control Panel	106
6.	Appendix	107
6.1.	Troubleshooting and Support	107
6.1.1.	Worldwide Support	107
6.1.2.	Before Contacting Technical Support	107
6.1.3.	Frequently Asked Questions	107
6.1.3.1.	What is the real transfer speed?	108
6.1.3.2.	Why can I not achieve maximum transfer speed?	108
6.2.	Product service request (PSR)	108
6.2.1.	Step 1 - Contact Support	108
6.2.2.	Step 2 - Create Product Service Request (PSR)	108
6.2.3.	Step 3 - Wait for PSR Approval	108
6.2.4.	Step 4 - Sending the camera to XIMEA	108
6.2.5.	Step 5 - Waiting for Service Conclusion	109
6.2.6.	STEP 6 - Waiting for return delivery	109
6.3.	Safety instructions and precautions	109
6.4.	Warranty	109
6.5.	List Of Trademarks	109
6.6.	Standard Terms & Conditions of XIMEA GmbH	109
6.7.	Copyright	109
6.8.	Revision History	110
7.	Glossary	111

8. list of figures 112
9. list of tables 114

Aegis Electronic Group
www.aegiselect.com

2. xiB / xiB-64 Camera Series



figure 2-1 xiB and xiB-64 camera with heat sinks.

2.1. What is xiB / xiB-64

xiB [ksi-bee: or sai-bee:] /xiB-64 is a compact PCI express Industrial camera family with outstanding features:

- Small footprint
- High speed computer interface
- Sensors for xiB: 12, 20, and 50 Mpixel CMOSIS CMOS sensors
- Sensors for xiB-64: 1, 2, 12, 16, 26 and 65 Mpixel CMOSIS and Luxima and GPixel sensors
- frame rates: 50 MP @ 30 fps to 1 MP @ 3,500+ fps

The XiB camera line uses a PCI Express (PCIe) computer interface which eliminates the need for a framegrabber. Currently, PCIe generations 2 and 3 are implemented for the xiB and xiB-64 camera lines. As a result, low latency communication between the camera head and host computer is achieved. Direct Memory Access (DMA) engine is utilized for data transfer between the camera and PC memory, reducing the CPU load to almost negligible values compared to other protocols.

Off the shelf hardware can be used for camera to computer interfaces, but testing was limited to the items discussed in this manual. See section 3.10 - 3.12 for materials needed to interface your camera to the computer. Both copper (10m) and fiber optic (>100m) cables are available for interfaces.

2.2. Advantages

Industry standard interface	Off the shelf components can be used – no ‘frame grabber’
Optional EF lens mount	Canon lenses controllable from software (focus and aperture)
Small	Fits into places where no other camera can fit
Powerful	Up to 64Gb/s (xiB-64)
Fast	High speed, high frame rate: up to 3500+fps (depending on the camera model)
Robust	Full metal housing, no sheet metal covers
Connectivity	Programmable opto-isolated I/O, and non-isolated digital input and output. 4 status LEDs
Compatibility	Support for Windows, Linux and MacOS, various Image Processing Libraries
Software interfaces	GenICam / GenTL and highly optimized xiAPI SDK
Economical	Excellent value and price, low TCO and fast ROI
Low latency	Computer CPU not involved in data transfer, latency from camera to memory is low

table 2-1, advantages

2.3. PCI Express Vision Camera Applications

- Automation
- High speed inspection
- Ultra-fast 3D scanning
- Material and Life science microscopy
- Ophthalmology and Retinal imaging
- Broadcasting
- Fast process capture, e.g. golf club swings
- Aerial Imaging

2.4. Common features

Sensor Technology	CMOS, Global shutter
Acquisition Modes	Continuous, software and hardware trigger, limited fps, triggered exposure and burst, exposure controlled by trigger length
Partial Image Readout	ROI, Skipping and Binning modes supported (model specific)
Image data formats	8, 10 or 12 bit RAW pixel data
Color image processing	Host based de-Bayering, sharpening, Gamma, color matrix, true color CMS
Hot/blemish pixels correction	On camera storage of more than 5000 pixel coordinates, host assisted correction
Auto adjustments	Auto white balance, auto gain, auto exposure
Flat field corrections	Host assisted pixel level shading and lens corrections
Image Data and Control Interface	iPass external PCIe connector (Gen2 x4 for xiB, and Gen3 x8 for xiB-64)
General Purpose I/O	2x opto-isolated input, 2x opto-isolated output, and 4 non-isolated I/O, 4X user configurable LEDs
Signal conditioning	Programmable debouncing time
Synchronization	Hardware trigger input, software trigger, exposure strobe output, busy output, ..
Housing and lens mount	Optional Canon EF mount available
Power requirements ¹	12-24V input, 9-29W
Environment	Operating 0°C to 50°C on housing, RH 80% non-condensing, -30°C to 70°C storage Ingress Protection: IP40
Operating systems	Windows 10 (x86 and x64), Linux Ubuntu, MacOS 10.8
Software support	xiAPI SDK, adapters and drivers for various image processing packages
Firmware updates	Field firmware updatable

table 2-2, common features

Note: 1) Power consumption is model specific

2.5. Model Nomenclature

Part number convention for the different models:

xiB family

CBxxxG-zz

xiB-64 family

CBxxxG-zz-X8G3

- CB** xiB and xiB-64 family name
- xxx:** Resolution in 0.1 MPixel. E.g. 1.3 MPixel Resolution: xxx = 013
- y:**
 - y=C: color model
 - y=M: black & white model
 - y=R: black & white, Infrared-extended model
- G:** Global shutter (all xiB & xiB-64 cameras are global shutter)
- zz:** Vendor of the sensor
 - zz = CM: CMOSIS
 - zz = LX: Luxima
 - zz = GP: Gpixel

Aegis Electronic Group
www.aegiselect.com

2.6. Models Overview, sensor and models



Model		Resolution	Pixel size	ADC [bit]	DR	Sensor diagonal	FPS ¹
CB120MG-CM	b/w	4096 × 3072	5.5 μm	8/10/12	60 dB	28.1 mm	133
CB120CG-CM	Color						
CB120RG-CM	b/w NIR						
CB200MG-CM	b/w	5120 × 3840	6.4 μm	12	66 dB	41 mm	32
CB200CG-CM	Color						
CB500MG-CM	b/w	7920 × 6004	4.6 μm	12	64 dB	45.6 mm	30
CB500CG-CM	Color						
CB013MG-LX-X8G3	b/w	1280 × 864	13.7 μm	10	60 dB	21.1 mm	3675
CB013CG-LX-X8G3	Color						
CB019MG-LX-X8G3	b/w	1920 × 1080	10.0 μm	10	60 dB	22 mm	2263
CB019CG-LX-X8G3	Color						
CB120MG-CM-X8G3	b/w	4096 × 3072	5.5 μm	8/10/12	60 dB	28.1 mm	330
CB120CG-CM-X8G3	Color						
CB120RG-CM-X8G3	b/w NIR						
CB160MG-LX-X8G3	b/w	4704 × 3424	3.9 μm	10	60 dB	22.7mm	311
CB160CG-LX-X8G3	Color						
CB262MG-GP-X8G3	b/w	5120 × 5120	2.5 μm	10, 12	63dB	18.1mm	150
CB262CG-GP-X8G3	Color						
CB262RG-GP-X8G3	b/w NIR						
CB654MG-GP-X8G3	b/w	9344 × 7000	3.2 μm	10, 12	64 dB	37.4mm	71
CB654CG-GP-X8G3	Color						

table 2-3, models overview

Note: 1) Full resolution, RAW8 format

2.7. Options

Most models are available as a board level version, please inquire

The Canon EF mount allows control of focus and aperture settings via software.

2.8. Accessories

The following accessories are available:

Item P/N	Description
MECH-60MM-BRACKET-T	xiB series tripod mounting bracket
MECH-60MM-EF-ADAPTER-KIT ¹	xiB / xiT Canon EF-Mount Adapter
MECH-60MM-HEATSINK-KIT ¹	xiB Heatsink kit
CB-X8G3-FAN-COOLER-KIT ¹	xiB-64 Heatsing Fan Cooler with Screws Kit
LA-C-MNT-60MM-KIT	C-mount lens adapter kit without filter glass
LA-C-MNT-60MM-BK7-KIT	C-mount lens adapter kit with BK7 filter glass
LA-C-MNT-60MM-IR650-KIT	C-mount lens adapter kit with IR650 filter glass
CBL-CB-PWR-SYNC-3M0	3.0m xiB series I/O Sync and power cable
CBL-MT-PWR-SYNC-3M0	3.0m xiT/xiB-64 series I/O Sync and AUX power cable
PEX4-G2-COP	PCIe Gen.2 x4 extender host adapter for copper cables
PEX4-G2-FIB-X2	PCIe Gen.2 x4 extender host adapter for fiber optics and copper cables 2-Port
PEX4-G3-FIB-X2	PCIe Gen.3 x4 extender host adapter for fiber optics and copper cables 2-Port
PEX4-G2-FIB	PCIe Gen.2 x4 extender host adapter for fiber optics cables
PEX8-G3-X1-DOL	PCIe Gen.3 x8 extender host adapter for copper and fiber optics cables
PEX8-G3-X2-OSS	PCIe Gen.3 x8 dual port extender host adapter for copper and fiber optics cables
CBL-PCI-COP-1M0	1.0m PCIe Gen.2 x4, copper cable
CBL-PCI-COP-3M0	3.0m, PCIe Gen.2 x4, copper cable
CBL-PCI-COP-5M0	5.0m, PCIe Gen.2 x4, copper cable
CBL-PCI-COP-7M0	7.0m, PCIe Gen.2 x4, copper cable
CBL-PCI-FIB-10M0	10.0m, PCIe Gen.2 x4, fiber optics cable
CBL-PCI-FIB-20M0	20.0m, PCIe Gen.2 x4, fiber optics cable
CBL-PCI-X8G3-COP-3M0	3.0m PCIe Gen.3 x8, copper cable
CBL-PCI-X8G3-FIB-10M0	10.0m PCIe Gen.3 x8 optical cable
CBL-PCI-X8G3-FIB-20M0	20.0m PCIe Gen.3 x8 optical cable
PSU-GSM60B24-P1J	desktop power supply (60W, 24V)

table 2-4, accessories

Notes: 1) These assemblies are sold separately. Additional assemblies purchased along with a camera can be added to the order at time of purchase for assembly with camera head. See table 2-5

Item P/N	Description
A-CB-X8G3-FAN-COOLER-KIT	Assembly Service for CB-X8G3-FAN-COOLER-KIT
A-MECH-60MM-EF-ADAPTER-KIT	Assembly Service for MECH-60MM-EF-ADAPTER-KIT
A-MECH-60MM-HEATSINK-KIT	Assembly Service for MECH-60MM-HEATSINK-KIT
A-LA-C-MNT-60MM-KIT	Assembly Service for LA-C-MNT-60MM-xxx-KIT

table 2-5, assembly options

3. Hardware Specification

3.1. Power Supply

The xiB and xiB-64 cameras are powered via their respective sync cables (CBL-CB-PWR-SYNC-3M0 (xiB) and CBL-MT-PWR-SYNC-3M0 (xiB-64)). See section [3.8 xiB, xiB-64 PCIe Interface](#) for details on the camera connector and input requirements.

The power required to run the camera varies on the camera model from 9-29W. Ximea sells a power supply to run the cameras. PSU-GSM60B24-P1J.

3.2. General Specification

3.2.1. Environment

Description	Value
Optimal ambient temperature operation	+10 to +25 °C
Ambient temperature operation	+0 to +50 °C
Ambient temperature for storage and transportation	-30 to +70 °C
Relative Humidity, non-condensing	80 %

table 3-1, environment

Housing temperature must not exceed +65°C. The following parameters are not guaranteed if the camera is operated outside the optimum range:

- Dark current
- Dynamic Range
- Linearity
- Acquisition
- Readout noise
- S/N ratio
- Durability

3.2.2. Firmware / Host driver / API features

Description	Value
Interpolation	Proprietary
White balance coefficients ranges	0.0 to 3.9
Sharpness filter	-400 to 400 %
Gamma	0.3 to 1.0
Full color correction matrix (3+1)x3 coefficients ranges	-3.9 to 3.9

table 3-2, firmware / API features

More details on API/SDK features are available at XIMEA support pages: <http://www.ximea.com/support>

3.3. Lens Mount

The xiB & xiB-64 cameras are compatible with the Canon EF mount.

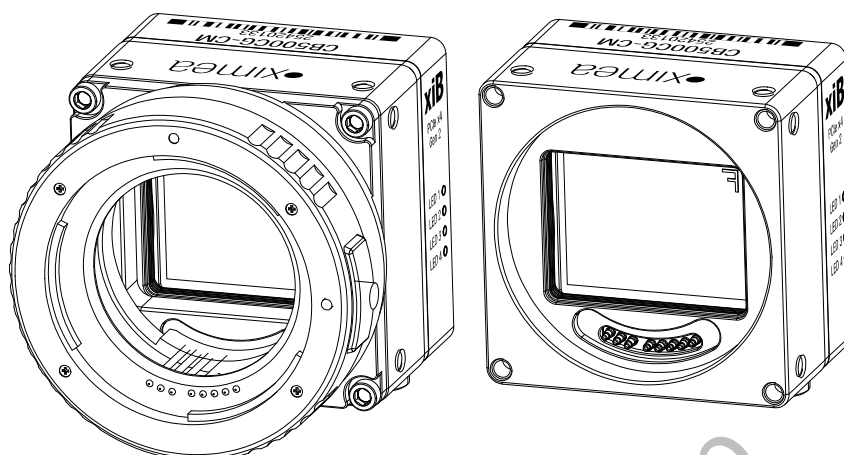

figure 3-1, xiB camera with/without the optional EF-Mount Adapter

The cameras are optionally delivered with or without outer EF-Mount Adapter.

Note: The distance between the outer EF-Mount Adapter and the active sensor surface is 44 mm and when no EF-Mount Adapter is included it is 13.4 mm.

Refer to [3.18 xiB Lens adapter – MECH-60MM-EF-ADAPTER](#) for more information.

xiB or xiB-64 cameras with 4/3" or smaller sensor format can also be equipped with C-mount lens adapter.

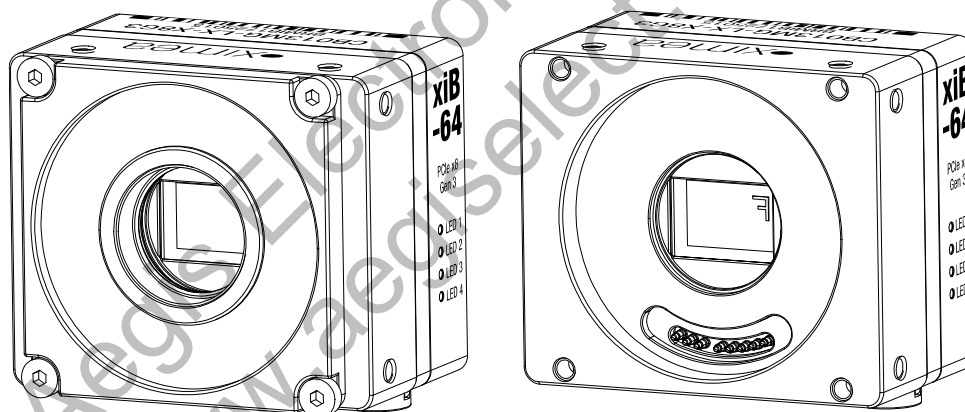

figure 3-2, xiB-64 camera with/without the optional C-Mount Adapter

Refer to [3.19 xiB Lens adapter – LA-C-MNT-60MM-xxx-KIT](#) for more information.

3.4. Mounting points

Mounting points available to the customer are shown below. All are M4 thread. Four mounting points at the front panel are used for the EF-mount adapter when installed.

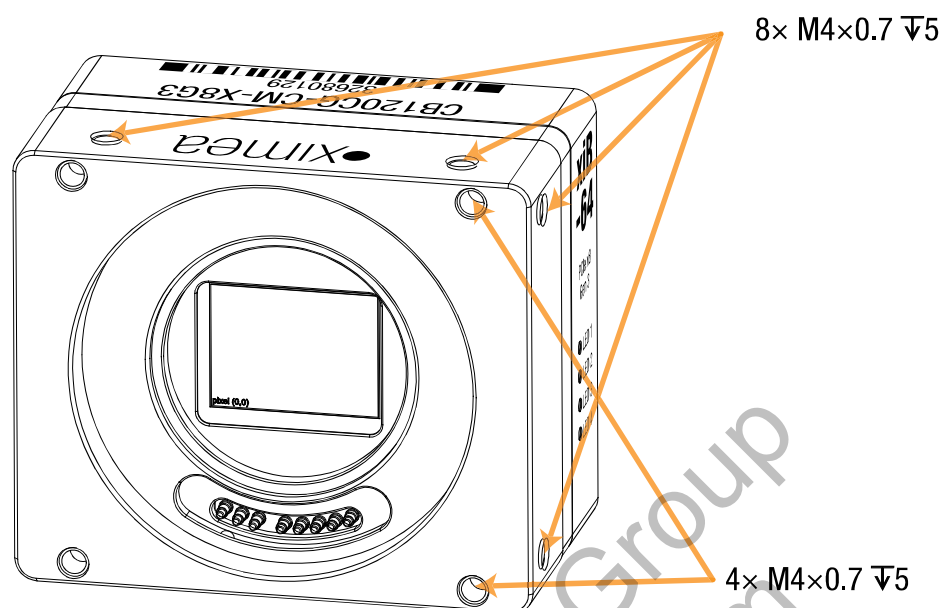

figure 3-3, drawing demonstrating the mounting hole positions. Camera shown without EF mount.

3.5. Optical path

No filter glass is added by Ximea. All windows are applied by the sensor vendor – see sensor vendor data sheets for optical path details.

Aegis Electronic Group
www.aegiselect.com

3.6. Model Specific Characteristics

3.6.1. CB120xG-CM

3.6.1.1. Sensor and camera parameters

xiB model	CB120CG-CM	CB120MG-CM	CB120RG-CM
Sensor parameter			
Part number	CMV12000-2E5C1PA	CMV12000-2E5M1PA	CMV12000-2E12M1PA
Color filter	RGB Bayer mosaic	None	None
Type	Global shutter		
Pixel Resolution (W x H) [pixel]	4096 x 3072		
Active area size (W x H) [mm]	22.5 x 16.9mm		
Sensor diagonal [mm]	28.16mm		
Optical format [inch]	APS-C		
Pixel Size [μm]	5.5μm		
ADC resolution [bit]	8, 10, 12		
FWC [ke-]	13.5		
Dynamic range [dB]	60		
SNR Max [dB]	TBD		
Conversion gain [e-/LSB ₁₂]	TBD		
Dark noise [e-]	TBD		
Dark current [e-/s]	22 @ RT 10-bit mode		
DSNU [e-]	2 in 10-bit mode		
PRNU [%]	<1.27%		
Linearity [%]	TBD		
Shutter efficiency	1/50,000		
Micro lenses	Yes		
Camera parameters			
Digitization [bit]	8, 10, 12		
Supported bit resolutions [bit/pixel]	8, 9, 10, 11, 12, 16		
Exposure time (EXP) [ms]	0.019 – 3500		
Variable Gain Range (VGA) [dB]	0-12dB ¹		
Refresh rate (MRR) [fps]	133/103/86 at 8/10/12 bit		
Power consumption²			
Stand by [W]	7.39		
Maximum [W]	9.9		
Dimensions/Mass			
height [mm]	60		
width [mm]	60		
depth [mm]	36 (w/o EF-Mount Adapter)		
mass [g]	159 (w/o EF-Mount Adapter)		

table 3-3, CB120xG-CM, sensor and camera parameters

Notes: 1) Analog gain has only discrete steps.

2) Measured at 24V with connected 10m fiber optical PCIe cable CBL-PCI-FIB-10M0. Optical cable consumption is about 1.25W.

Binning/skipping	Output resolution	Bit/px	fps	Readout time [ms]
1x1/1x1	4096 x 3072	8	137	7.51
1x1/2x2	2048 x 1536	8	544	2.23
2x2/1x1	2048 x 1536	8	200	4.98
1x1/1x1	4096 x 3072	10	109	9.05
1x1/2x2	2048 x 1536	10	437	2.23
2x2/1x1	2048 x 1536	10	267	3.73
1x1/1x1	4096 x 3072	12	90	9.74
1x1/2x2	2048 x 1536	12	359	2.26
2x2/1x1	2048 x 1536	12	267	3.73

table 3-4, CB120xG-CM, standard readout modes

3.6.1.2. Quantum efficiency curves [%]

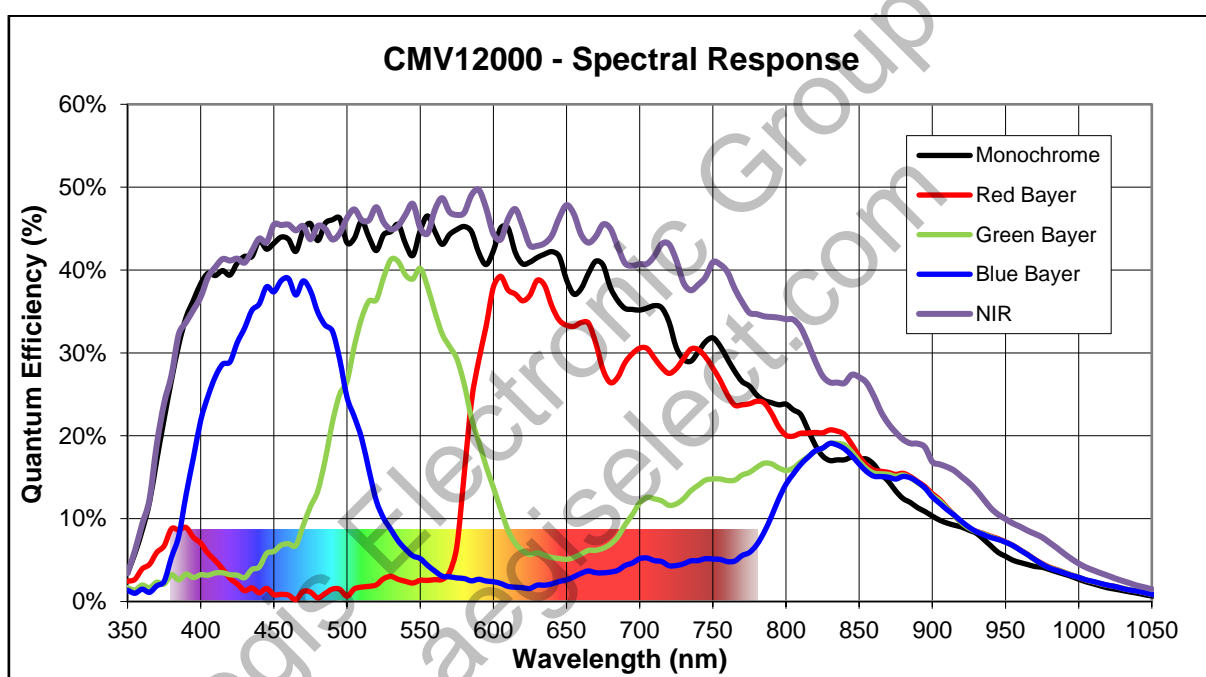

figure 3-4, CMV12000-mono, color and NIR, quantum efficiency curve, ©CMOSIS

3.6.1.3. Dimensional drawings CB120xG-CM

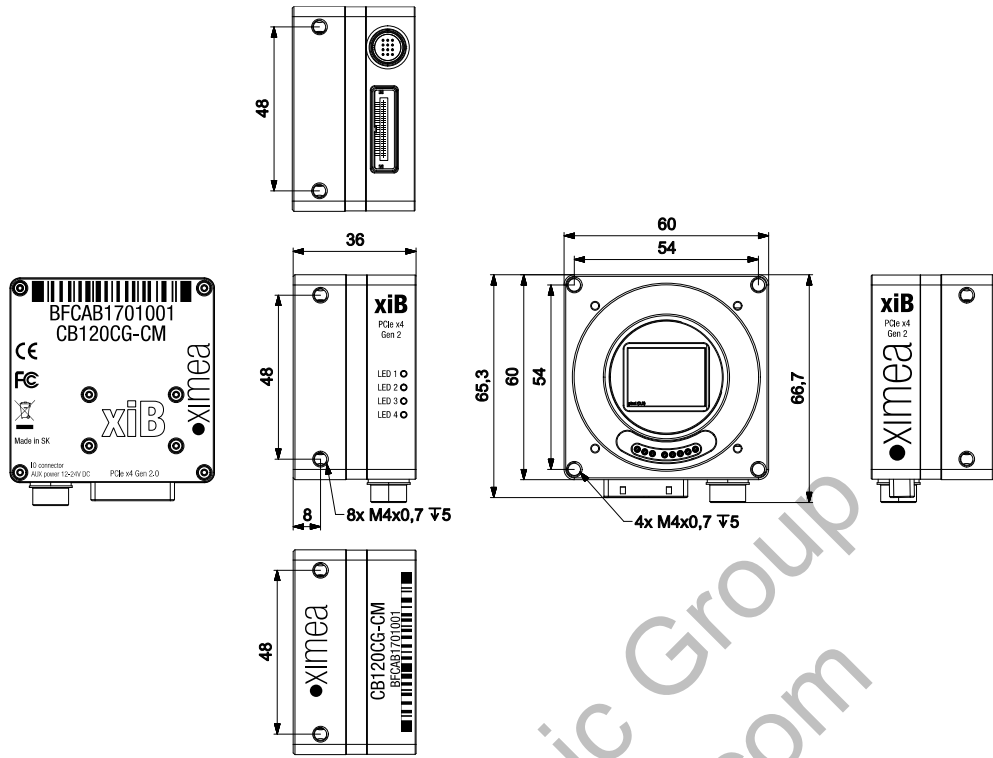

figure 3-5, dimensional drawing CB120xG-CM

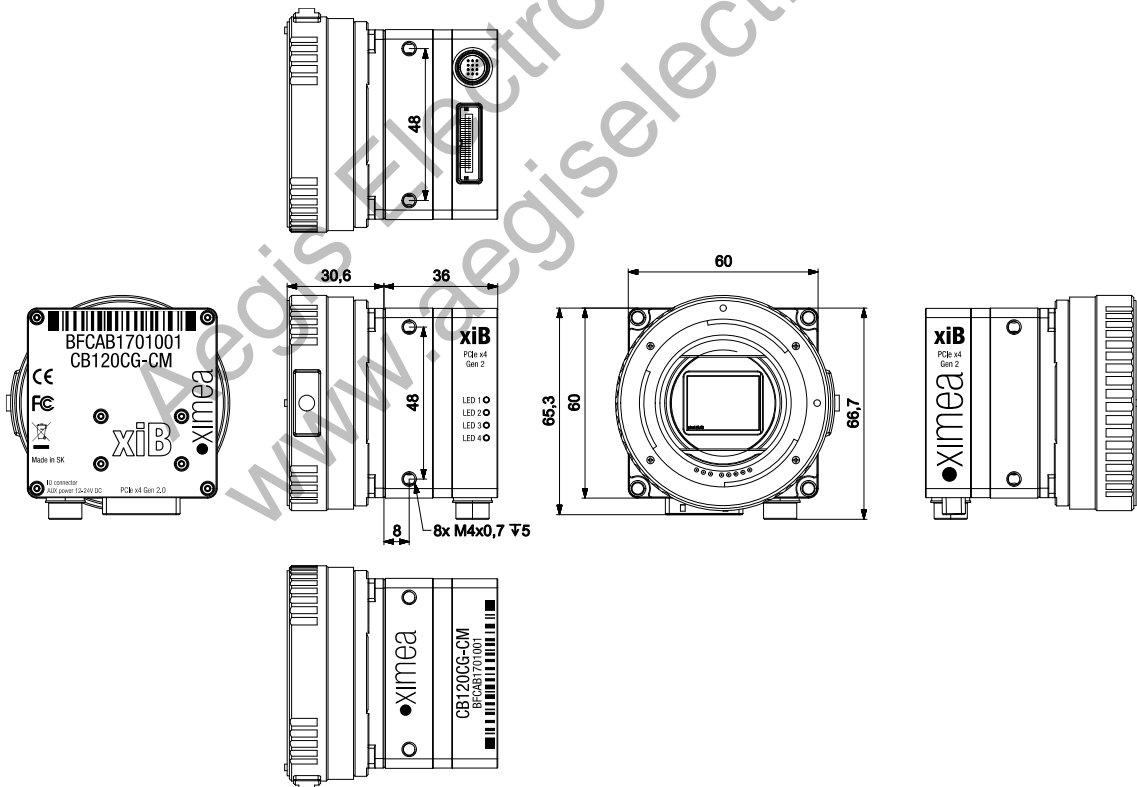

figure 3-6, dimensional drawing CB120xG-CM, with EF-mount adapter

3.6.1.4. Referenced documents

CMOSIS datasheet CMV12000 datasheet v2.11

3.6.1.5. Sensor features

feature	Note
Binning	Yes 2x2
Skipping	Yes 2x2
ROI	Vertical cropping results in increased read speed, horizontal reduces data transfer
HW Trigger	Trigger with overlap (see 4.4.2 Trigger controlled Acquisition/Exposure)
HDR	Not available

table 3-5, sensor features available

Aegis Electronic Group
www.aegiselect.com

3.6.2. CB200xG-CM

3.6.2.1. Sensor and camera parameters

xiB model	CB200CG-CM	CB200MG-CM
Sensor parameter		
Part number	CMV20000-1E5C1PA	CMV20000-1E5M1PA
Color filter	RGB Bayer mosaic	None
Type	Global shutter	
Pixel Resolution (W x H) [pixel]	5120 x 3840	
Active area size (W x H) [mm]	32.8 x 24.6mm	
Sensor diagonal [mm]	40.96mm	
Optical format	Full frame	
Pixel Size [μm]	6.4 μm	
ADC resolution [bit]	12	
FWC [ke-]	15	
Dynamic range [dB]	66	
SNR Max [dB]	TBD	
Conversion gain [e-/LSB ₁₂]	TBD	
Dark noise [e-]	TBD	
Dark current [e-/s]	125e-/s @ RT	
DSNU [e-]	10	
PRNU %	TBD	
Linearity [%]	TBD	
Shutter efficiency	1/50,000	
Micro lenses	Yes	
Camera parameters		
Digitization [bit]	12	
Supported bit resolutions [bit/pixel]	8, 9, 10, 11, 12, 16	
Exposure time (EXP) [ms]	0.094 – 1050	
Variable Gain Range (VGA) [dB]	0- 2.55 ¹	
Refresh rate (MRR) [fps]	32 @ 12 bit	
Power consumption		
Stand by [W]	6.6	
Maximum [W]	9.0	
Dimensions/Mass		
height [mm]	60	
width [mm]	60	
depth [mm]	38 (w/o EF mount)	
mass [g]	164 (w/o EF mount)	

table 3-6, CB200xG-CM, sensor and camera parameters

Notes: 1) Analog gain has only several discrete steps.

2) Measured at 24V with connected 10m fiber optical PCIe cable CBL-PCI-FIB-10M0. Optical cable consumption is about 1.25W.

Binning/skipping	Output resolution	Bit/px	fps	Readout time [ms]
1x1/1x1	5120 × 3840	8, 10, 12	32.5	30.7

table 3-7, CB200xG-CM, standard readout modes

3.6.2.2. Quantum efficiency curves [%]

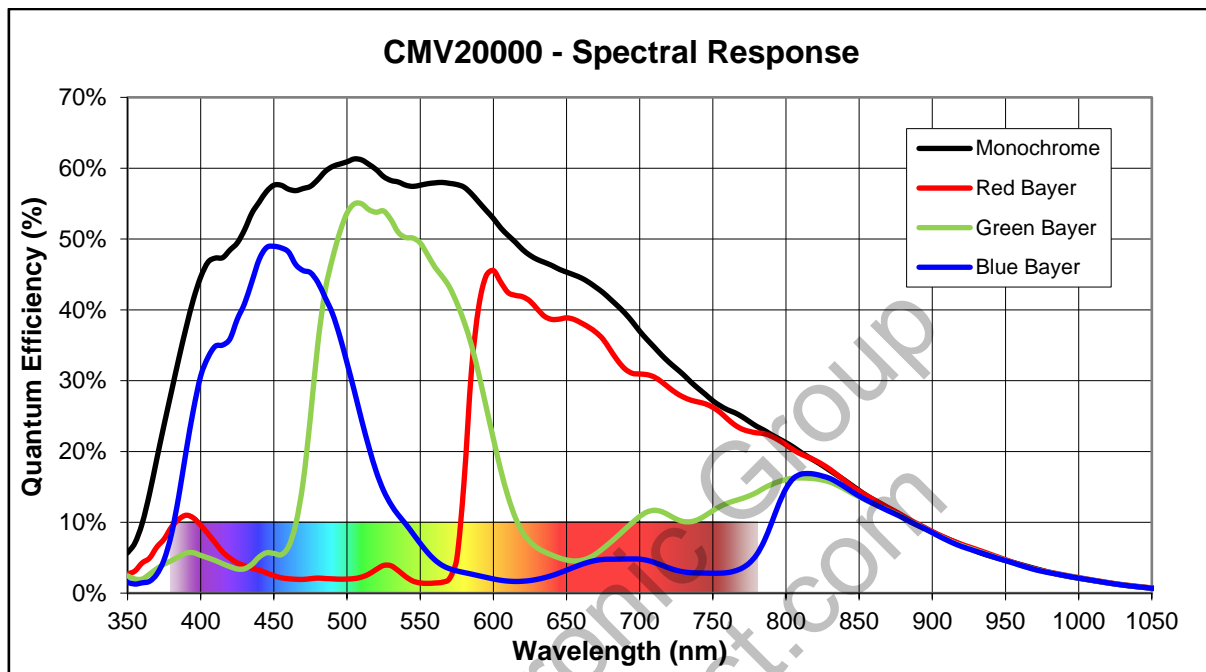

figure 3-7, CMV20000 mono and color, quantum efficiency curve, ©CMOSIS

3.6.2.3. Dimensional drawings CB200xG-CM

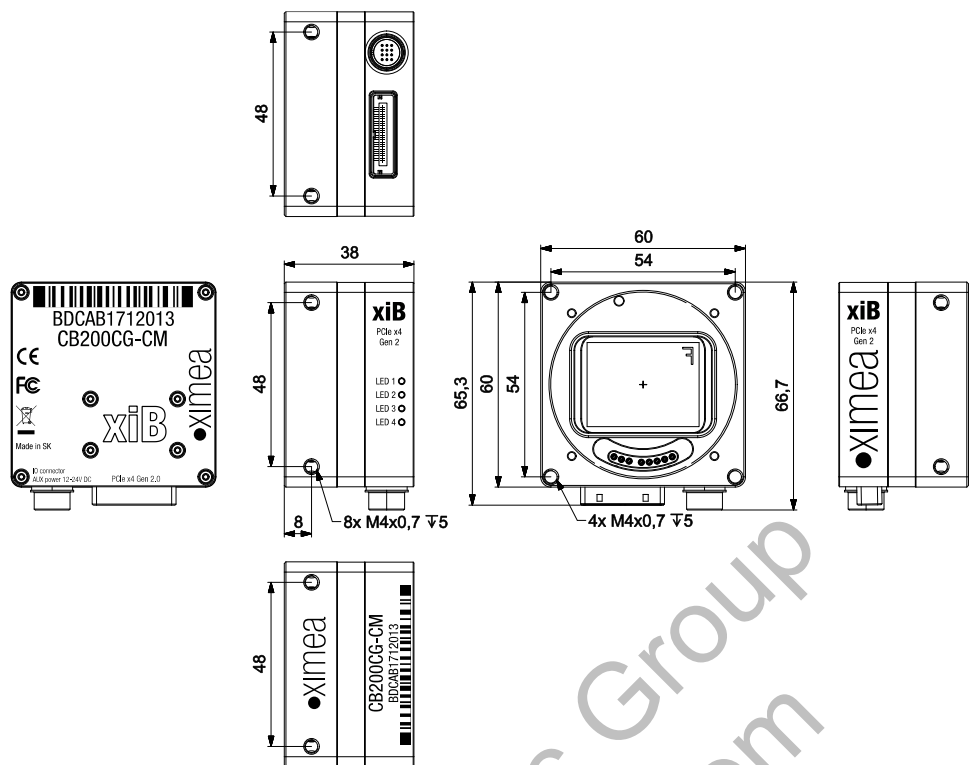

figure 3-8, dimensional drawing CB200xG-CM with EF-mount adapter

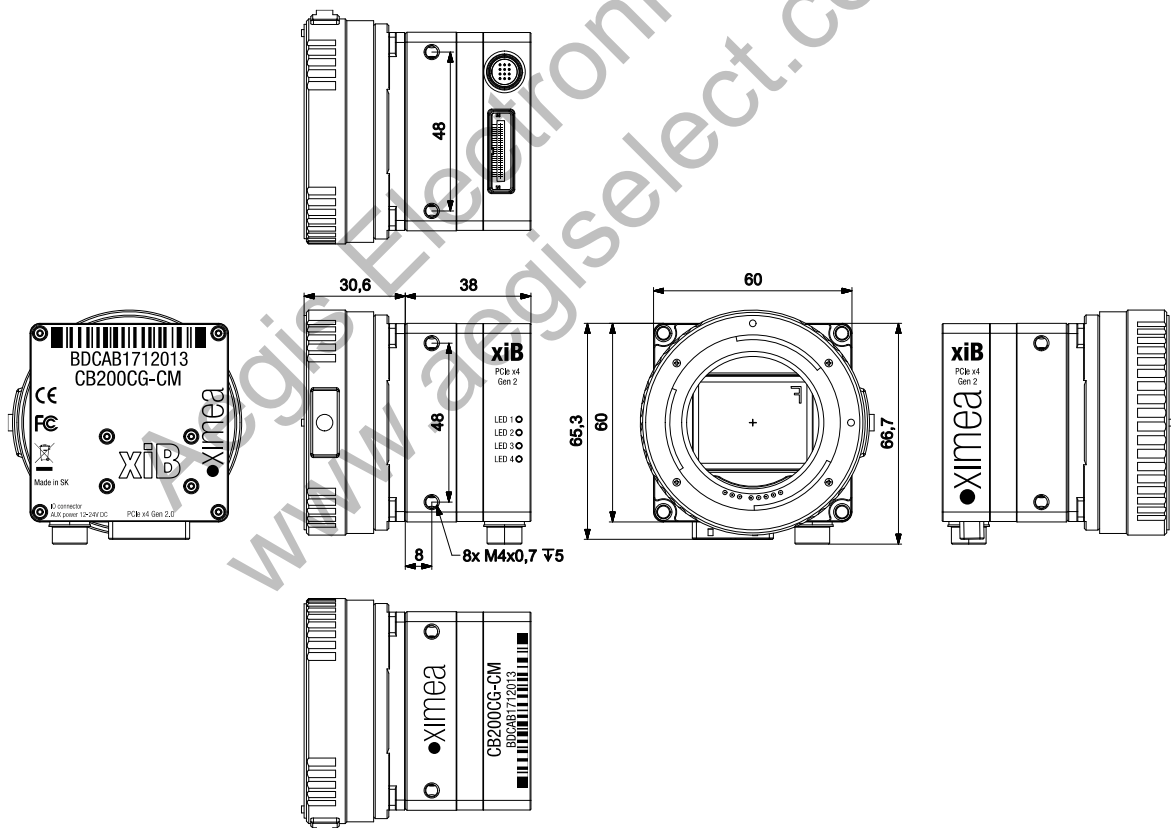

figure 3-9, dimensional drawing CB200xG-CM with EF-mount adapter

3.6.2.4. Referenced documents

CMOSIS datasheet CMV20000 v2.3_2

3.6.2.5. Sensor features

feature	Note
Binning	No
Skipping	No
ROI	Vertical cropping results in increased readout speed, horizontal reduces data transfer
HW Trigger	Trigger without overlap usable (see 4.4.2 Trigger controlled Acquisition/Exposure)
HDR	Supported

table 3-8, sensor features available

Aegis Electronic Group
www.aegiselect.com

3.6.3. CB500xG-CM

3.6.3.1. Sensor and camera parameters

xiB model	CB500CG-CM	CB500MG-CM
Sensor parameter		
Part number	CMV50000-1E3C1PA	CMV50000-1E3M1PA
Color filter	RGB Bayer mosaic	None
Type	Global shutter	
Pixel Resolution (H × W) [pixel]	7920 x 6004	
Active area size (H × W) [mm]	36.4 x 27.6	
Sensor diagonal [mm]	45.72	
Optical format [inch]	Slightly bigger than 'full frame'	
Pixel Size [μm]	4.6	
ADC resolution [bit]	12	
FWC [ke-]	14.5	
Dynamic range [dB]	64	
SNR Max [dB]	41.6	
Conversion gain [e-/LSB ₁₂]	3.58	
Dark noise [e-]	8.8	
Dark current [e-/s]	33	
DSNU [e-]	24.5	
PRNU [%]	< 1.0	
Linearity [%]	< 0.5	
Shutter efficiency	1/18000	
Micro lenses	yes	
Camera parameters		
Digitization [bit]	12	
Supported bit resolutions [bit/pixel]	8, 9, 10, 11, 12, 16	
Exposure time (EXP) [ms]	0.1 – 1050	
Variable Gain Range (VGA) [dB]	0-12	
Refresh rate (MRR) [fps]	32 @ 8-bit/pixel	
Power consumption		
typical [W]	9	
Maximum [W]	9.5	
Mechanical		
height [mm]	60	
width [mm]	60	
depth [mm]	37.8 (w/o EF mount)	
mass [g]	170 (w/o EF mount)	

table 3-9, CB500xG-CM, sensor and camera parameters

Notes: 1) Analog gain has only several discrete steps.

Binning/skipping	Output resolution	Bit/px	fps	Readout time [ms]
1x1/1x1	7920 × 6004	8	30.9	32.36
1x1/1x1	7920 × 6004	10	28.8	34.70
1x1/1x1	7920 × 6004	12	24.1	41.62
1x1/1x2	7920 × 3002	8	61.4	16.29
1x1/1x2	7920 × 3002	10	57.1	17.48
1x1/1x2	7920 × 3002	12	47.9	20.94
1x1/2x2	3960 × 3000	8	61.4	16.29
1x1/2x2	3960 × 3000	10	61.4	16.29
1x1/2x2	3960 × 3000	12	61.4	16.29
2x2/1x1	3960 × 3000	8	30.8	32.43
2x2/1x1	3960 × 3000	10	30.8	32.43
2x2/1x1	3960 × 3000	12	30.8	32.43

table 3-10, CB500xG-CM, standard readout modes

3.6.3.2. Quantum efficiency curves [%]

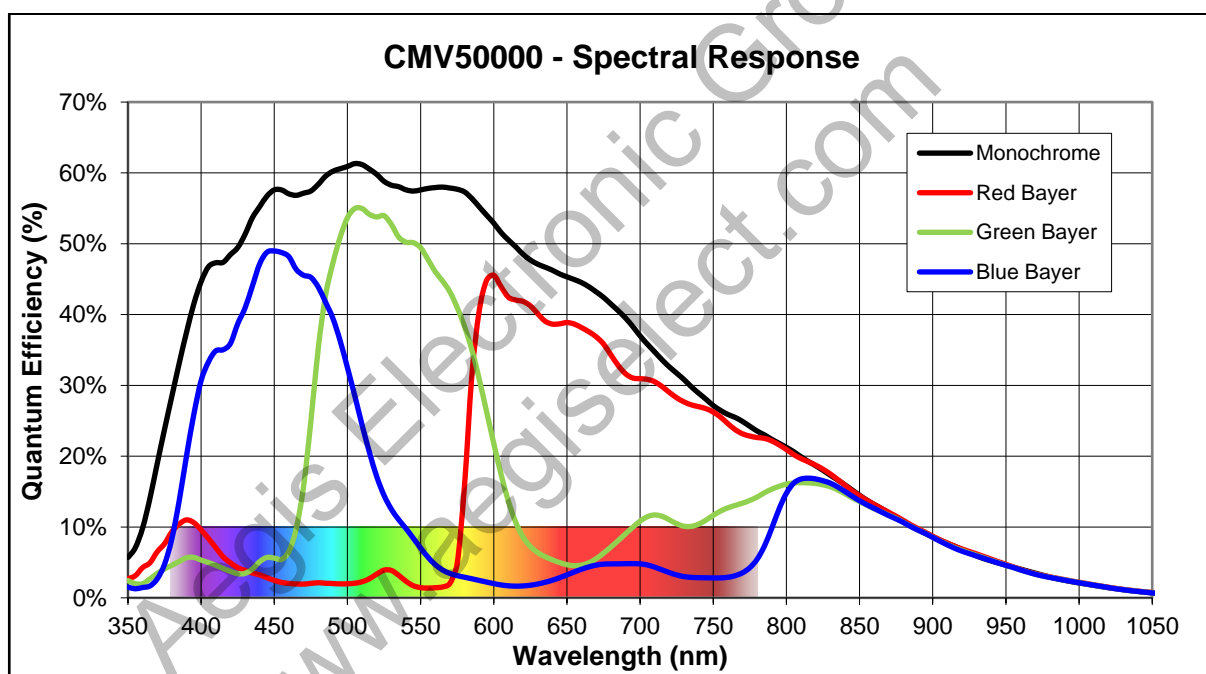

figure 3-10 CMV50000 Quantum Efficiency ©CMOSIS

3.6.3.3. Dimensional drawings CB500xG-CM (with and without EF mount)

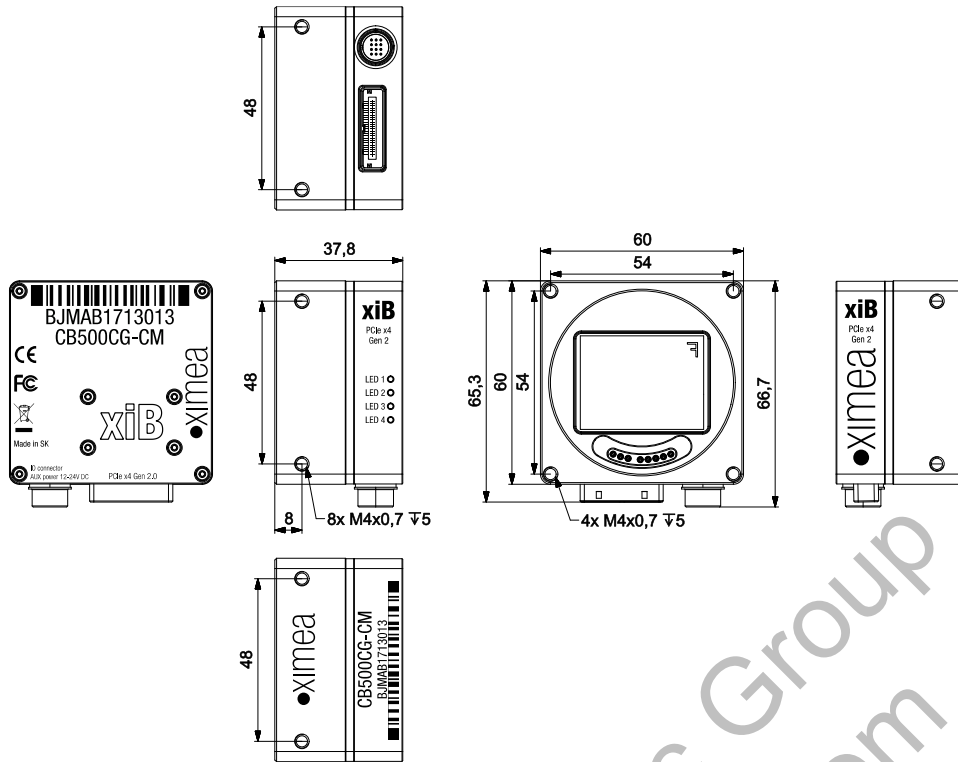

figure 3-11, dimensional drawing CB500xG-CM w/o EF-mount adapter

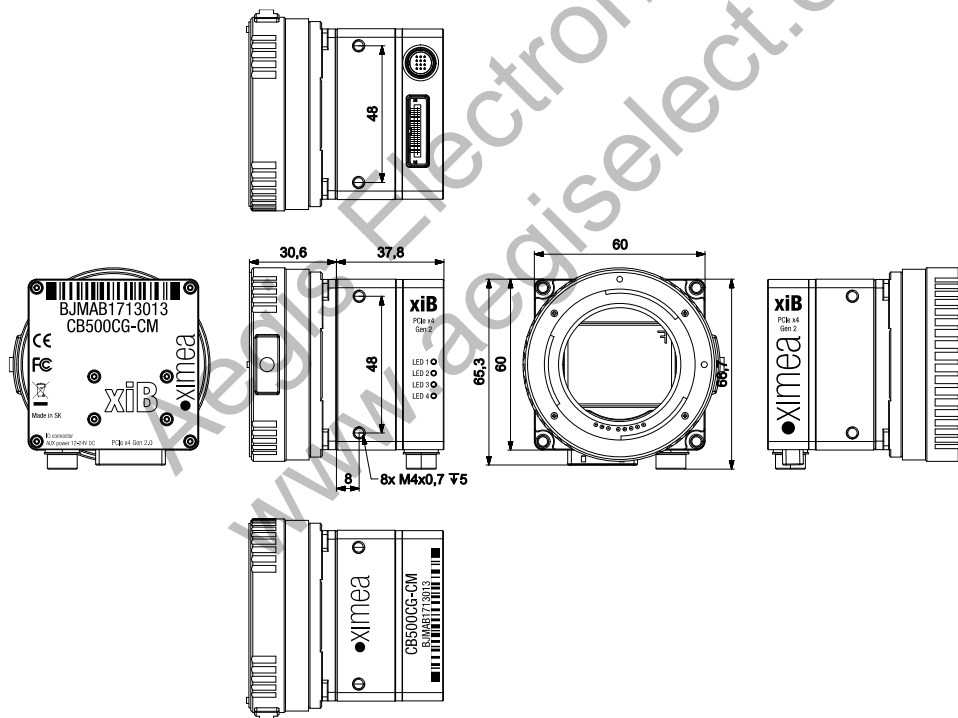

figure 3-12, dimensional drawing CB500xG-CM with EF-mount adapter

3.6.3.4. Referenced documents

CMOSIS Datasheet CMV50000 v0.11

3.6.3.5. Sensor features

feature	Note
Binning	Yes, 2x2
Skipping	Yes, 2x2
ROI	Vertical cropping results in increased read speed, horizontal reduces data transfer
HW Trigger	Trigger with overlap usable (see 4.4.2 Trigger controlled Acquisition/Exposure)
HDR	Not available

table 3-11, sensor features available

Aegis Electronic Group
www.aegiselect.com

3.6.4. CB013xG-LX-X8G3

3.6.4.1. Sensor and camera parameters

xiB-64 model	CB013CG-LX-X8G3	CB013MG-LX-X8G3
Sensor parameter		
Part number	LUX13HSC	LUX13HSM
Color filter	RGB Bayer mosaic	None
Type	Global shutter	
Pixel Resolution (W x H) [pixel]	1280 × 864	
Active area size (W x H) [mm]	17.5 × 11.8	
Sensor diagonal [mm]	21.2	
Optical format [inch]	4/3"	
Pixel Size [μm]	13.7	
ADC resolution [bit]	10	
FWC [ke-]	20	
Dynamic range [dB]	60	
SNR Max [dB]	TBD	
Conversion gain [e-/LSB ₁₂]	TBD	
Dark noise [e-]	14	
Dark current [e-/s]	TBD	
DSNU [e-]	TBD	
PRNU [%]	<1.5	
Linearity [%]	TBD	
Shutter efficiency	TBD	
Micro lenses	TBD	
Camera parameters		
Digitization [bit]	10	
Supported bit resolutions [bit/pixel]	8, 9, 10, 11, 12, 16	
Exposure time (EXP) [ms]	0.001 – 1000	
Variable Gain Range (VGA) [dB]	0-18dB	
Refresh rate (MRR) [fps]	3675 (10-bit)	
Power consumption		
typical [W]	13.8(25.6) ¹	
Maximum [W]	17.8(27) ¹	
Mechanical		
height [mm]	60	
width [mm]	70	
depth [mm]	41 (w/o EF-mount adapter and active cooling)	
mass [g]	268 (w/o EF-mount adapter and active cooling)	

table 3-12, CB013xG-LX-X8G3, sensor and camera parameters

Notes: 1) Hardware revision 2 power consumption in brackets. Produced till Q3/2019

Binning/skipping	Output resolution	Bit/px	fps	Readout time [ms]
1x1/1x1	1280 × 864	8/10	3675	0.272

table 3-13, CB013xG-LX-X8G3, standard readout modes

3.6.4.2. Quantum efficiency curves [%]

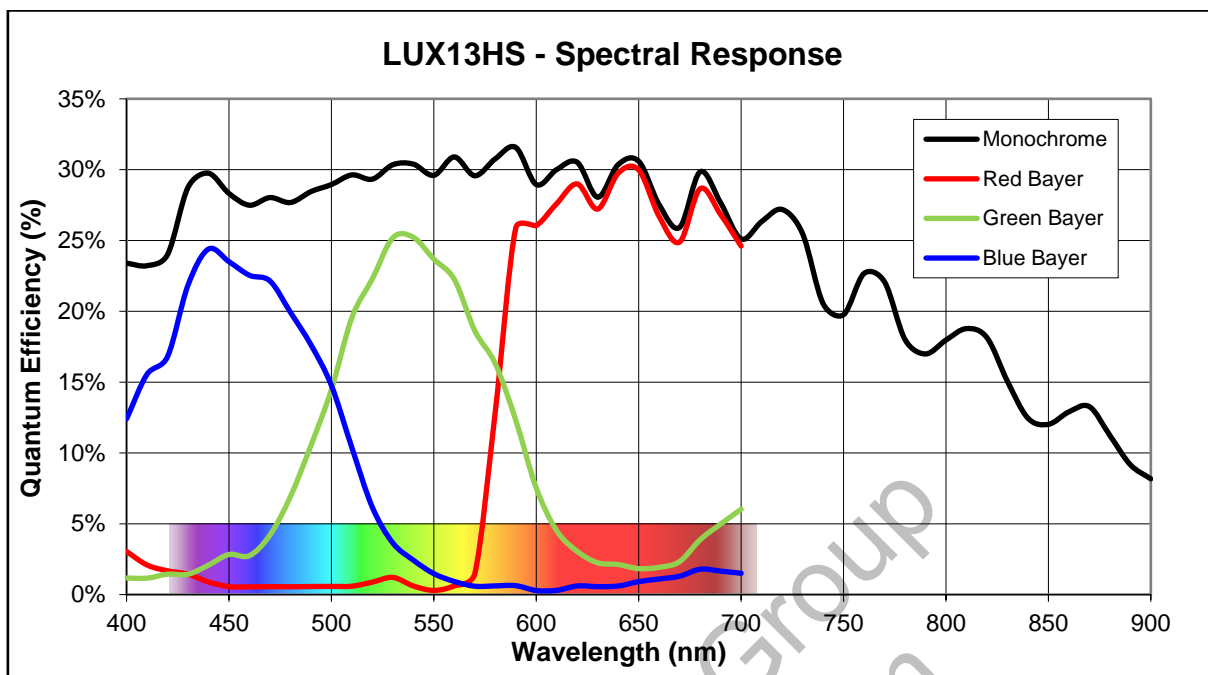

figure 3-13, LUX13HS quantum efficiency chart ©Luxima

Aegis Electronic Group
www.aegiselect.com

3.6.4.3. Dimensional drawings CB013xG-LX-X8G3

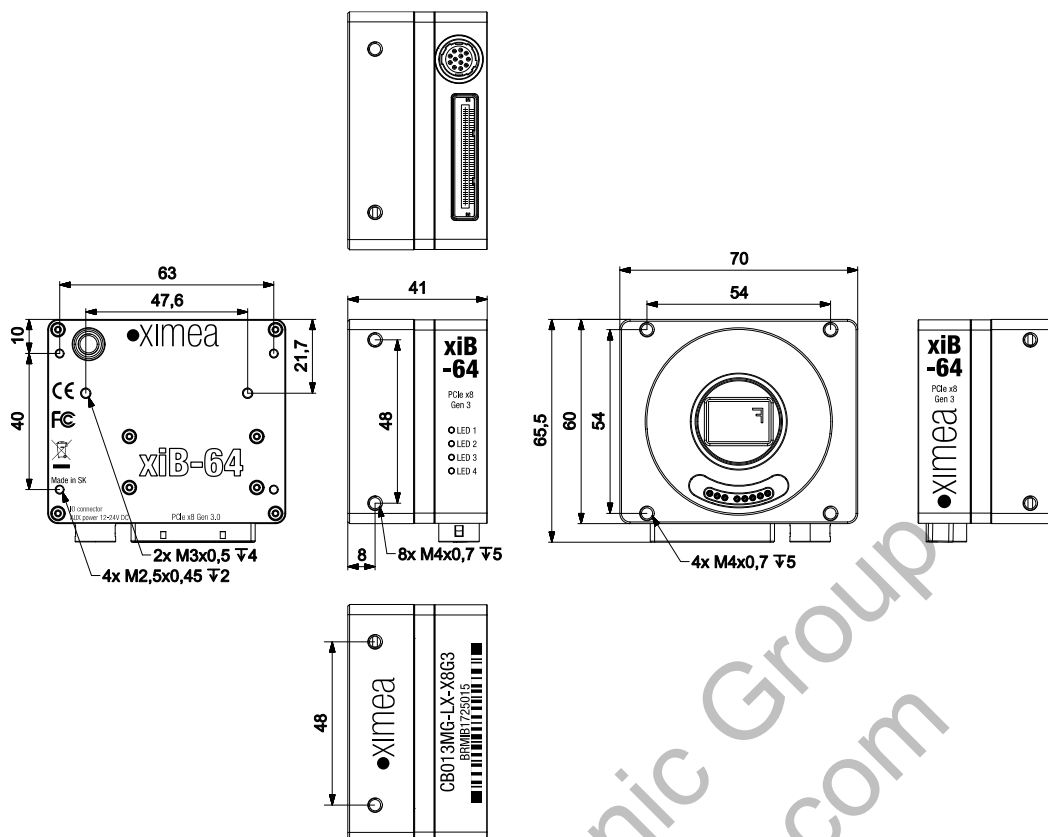

figure 3-14, dimensional drawing CB013xG-LX-X8G3 without EF-mount adapter

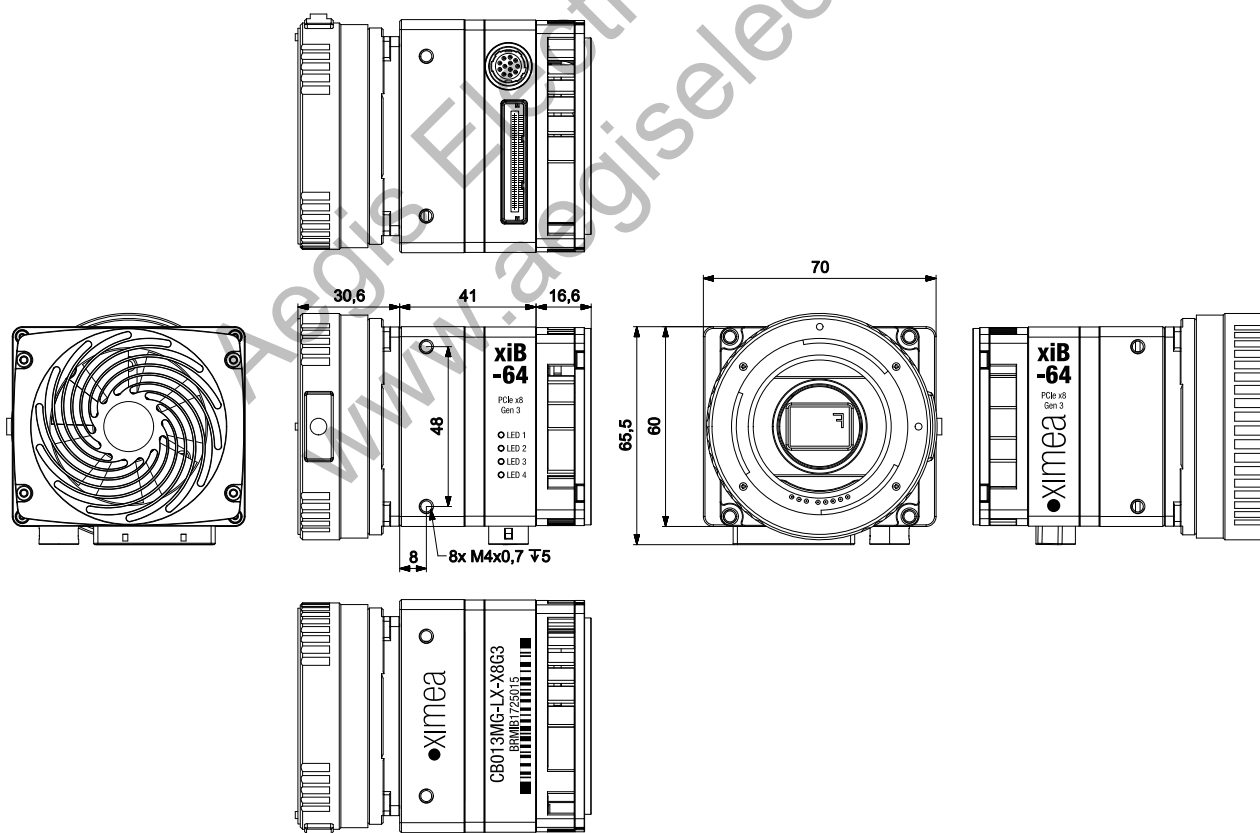

figure 3-15, dimensional drawing CB013xG-LX-X8G3 with EF-mount adapter and fan cooler unit

3.6.4.4. Referenced documents

Luxima Datasheet LUX13_HS_Datasheet_V2.3

3.6.4.5. Sensor features

feature	Note
Binning	No
Skipping	No
ROI	Vertical cropping results in increased read speed, horizontal reduces data transfer
HW Trigger	Trigger with overlap usable (see 4.4.2 Trigger controlled Acquisition/Exposure)
HDR	Not available

table 3-14, sensor features available

Aegis Electronic Group
www.aegiselect.com

3.6.5. CB019xG-LX-X8G3

3.6.5.1. Sensor and camera parameters

xiB-64 model	CB019CG-LX-X8G3	CB019MG-LX-X8G3
Sensor parameter		
Part number	LUX19HSC	LUX19HSM
Color filter	RGB Bayer mosaic	None
Type	Global shutter	
Pixel Resolution (W x H) [pixel]	1920 × 1080	
Active area size (W x H) [mm]	19.2 × 10.8	
Sensor diagonal [mm]	22.0	
Optical format [inch]	4/3"	
Pixel Size [μm]	10	
ADC resolution [bit]	10	
FWC [ke-]	15	
Dynamic range [dB]	60	
SNR Max [dB]	41	
Conversion gain [e-/LSB ₁₂]	TBD	
Dark noise [e-]	10	
Dark current [e-/s]	TBD	
DSNU [e-]	TBD	
PRNU [%]	<1.5	
Linearity [%]	TBD	
Shutter efficiency	TBD	
Micro lenses	TBD	
Camera parameters		
Digitization [bit]	10	
Supported bit resolutions [bit/pixel]	8, 9, 10, 11, 12, 16	
Exposure time (EXP) [ms]	0.001 – 1000	
Variable Gain Range (VGA) [dB]	0-18dB	
Refresh rate (MRR) [fps]	2263 (10-bit)	
Power consumption		
Typical [W]	13.9(25.8) ¹	
Maximum [W]	18.0(27.0) ¹	
Mechanical		
height [mm]	60	
width [mm]	70	
depth [mm]	41 (w/o EF-mount adapter and active cooling)	
mass [g]	268 (w/o EF-mount adapter and active cooling)	

table 3-15, CB019xG-LX-X8G3, sensor and camera parameters

Notes: 1) Hardware revision 2 power consumption in brackets. Produced till Q3/2019

Binning/skipping	Output resolution	Bit/px	fps	Readout time [ms]
1x1/1x1	1920 × 1080	8/10	2263	0.441

table 3-16, CB019xG-LX-X8G3, standard readout modes

3.6.5.2. Quantum efficiency curves [%]

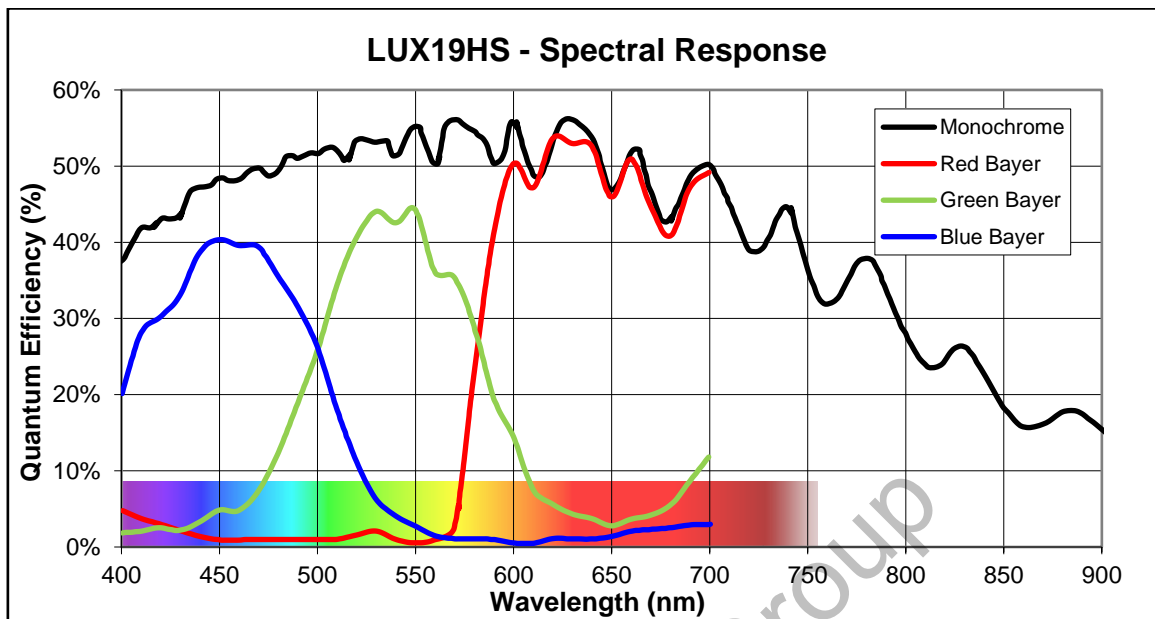

figure 3-16, LUX19HS quantum efficiency chart ©Luxima

Aegis Electronic Group
www.aegiselect.com

3.6.5.3. Dimensional drawings CB019xG-LX-X8G3

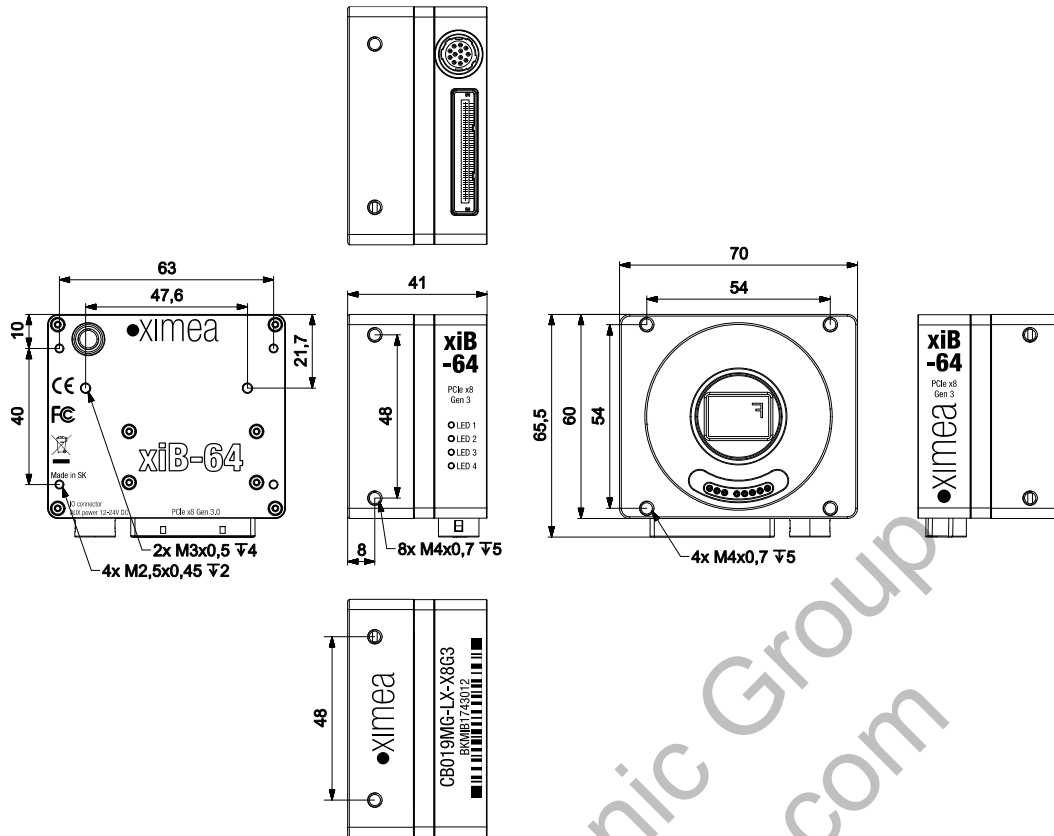

figure 3-17, dimensional drawing CB019xG-LX-X8G3 without EF-mount adapter

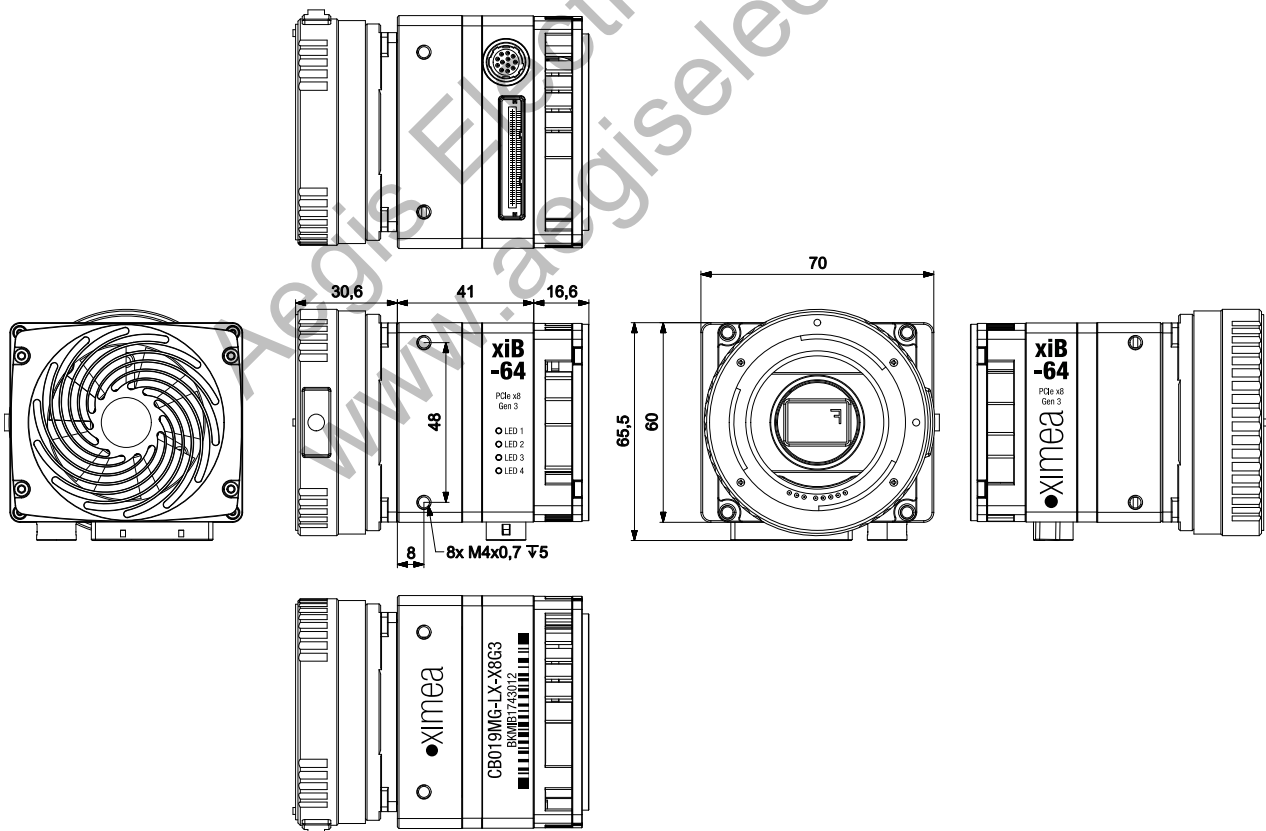

figure 3-18, dimensional drawing CB019xG-LX-X8G3 with EF-mount adapter and fan cooler unit

3.6.5.4. Referenced documents

Luxima Datasheet LUX19_HS_Datasheet_V2.3

3.6.5.5. Sensor features

feature	Note
Binning	No
Skipping	No
ROI	Vertical cropping results in increased read speed, horizontal reduces data transfer
HW Trigger	Trigger with overlap usable (see 4.4.2 Trigger controlled Acquisition/Exposure)
HDR	Not available

table 3-17, sensor features available

Aegis Electronic Group
www.aegiselect.com

3.6.6. CB120xG-CM-X8G3

3.6.6.1. Sensor and camera parameters

xiB model	CB120CG-CM-X8G3	CB120MG-CM-X8G3	CB120RG-CM-X8G3
Sensor parameter			
Part number	CMV12000-2E5C1PA	CMV12000-2E5M1PA	CMV12000-2E12M1PA
Color filter	RGB Bayer mosaic	None	None
Type	Global shutter		
Pixel Resolution (W x H) [pixel]	4096 x 3072		
Active area size (W x H) [mm]	22.5 x 16.9mm		
Sensor diagonal [mm]	28.16mm		
Optical format [inch]	APS-C		
Pixel Size [µm]	5.5µm		
ADC resolution [bit]	8, 10, 12		
FWC [ke-]	13.5		
Dynamic range [dB]	60		
SNR Max [dB]	41.5		
Conversion gain [e-/LSB ₁₂]	3.33		
Dark noise [e-]	13		
Dark current [e-/s]	22 @ RT 10-bit mode		
DSNU [e-]	2 in 10-bit mode		
PRNU [%]	<1.27%		
Linearity [%]	TBD		
Shutter efficiency	1/50,000		
Micro lenses	Yes		
Camera parameters			
Digitization [bit]	8, 10, 12		
Supported bit resolutions [bit/pixel]	8, 9, 10, 11, 12, 16		
Exposure time (EXP) [ms]	0.019 – 3500		
Variable Gain Range (VGA) [dB]	0-12dB ¹		
Refresh rate (MRR) [fps]	330 at 8 bit		
Power consumption			
Typical [W]	17.8 (24.8) ³		
Maximum [W]	20.4 (29.1) ³		
Mechanical			
height [mm]	60		
width [mm]	70		
depth [mm]	40 (w/o EF-mount adapter and active cooling)		
mass [g]	280 (w/o EF-mount adapter and active cooling)		

table 3-18, CB120xG-CM-X8G3, sensor and camera parameters

Notes: 1) Analog gain has only several discrete steps.

2) Measured at 24V with connected 10m fiber optical PCIe cable CBL-PCI-X8G3-FIB-10M0. Optical cable consumption is about 2.5W

3) Hardware revision 2 power consumption in brackets. Produced till Q3/2019

Binning/skipping	pixels	Bit/px	fps	Readout time [ms]
1x1/1x1	4096 x 3072	8	335	2.98
1x1/2x2	2048 x 1536	8	791	1.26
2x2/1x1	2048 x 1536	8	251	3.98
1x1/1x1	4096 x 3072	10	296	3.33
1x1/2x2	2048 x 1536	10	1049	0.95
2x2/1x1	2048 x 1536	10	267	3.73
1x1/1x1	4096 x 3072	12	132	7.57
1x1/2x2	2048 x 1536	12	528	1.89
2x2/1x1	2048 x 1536	12	267	3.73

table 3-19, CB120xG-CM-X8G3, standard readout modes

3.6.6.2. Quantum efficiency curves [%]

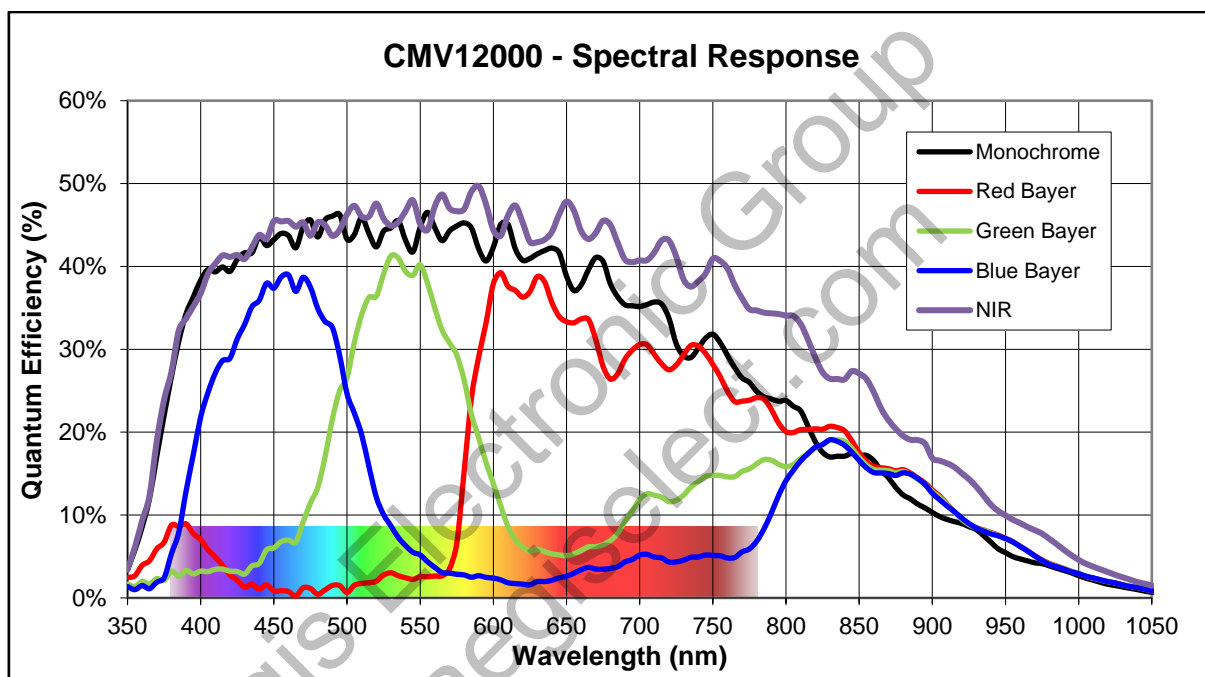

figure 3-19, CMV12000-mono, color and NIR, quantum efficiency curve, ©CMOSIS

3.6.6.3. Dimensional drawings CB120xG-CM-X8G3

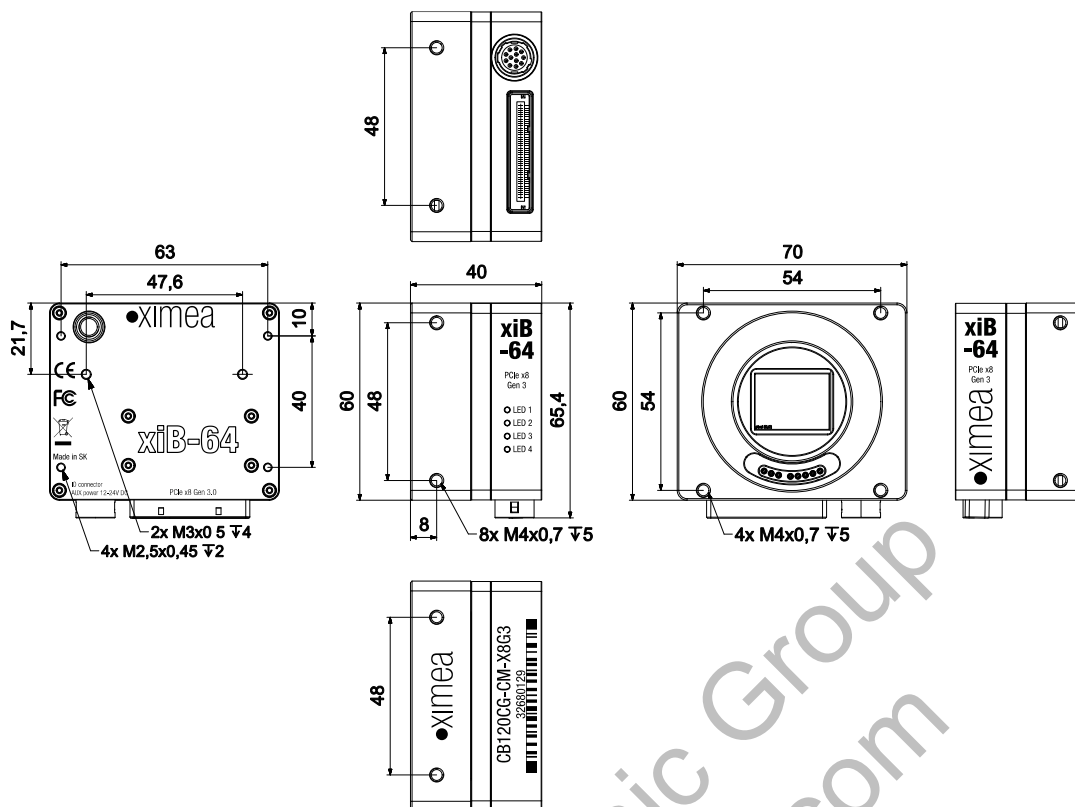

figure 3-20, dimensional drawing CB120xG-CM-X8G3 without EF-mount adapter

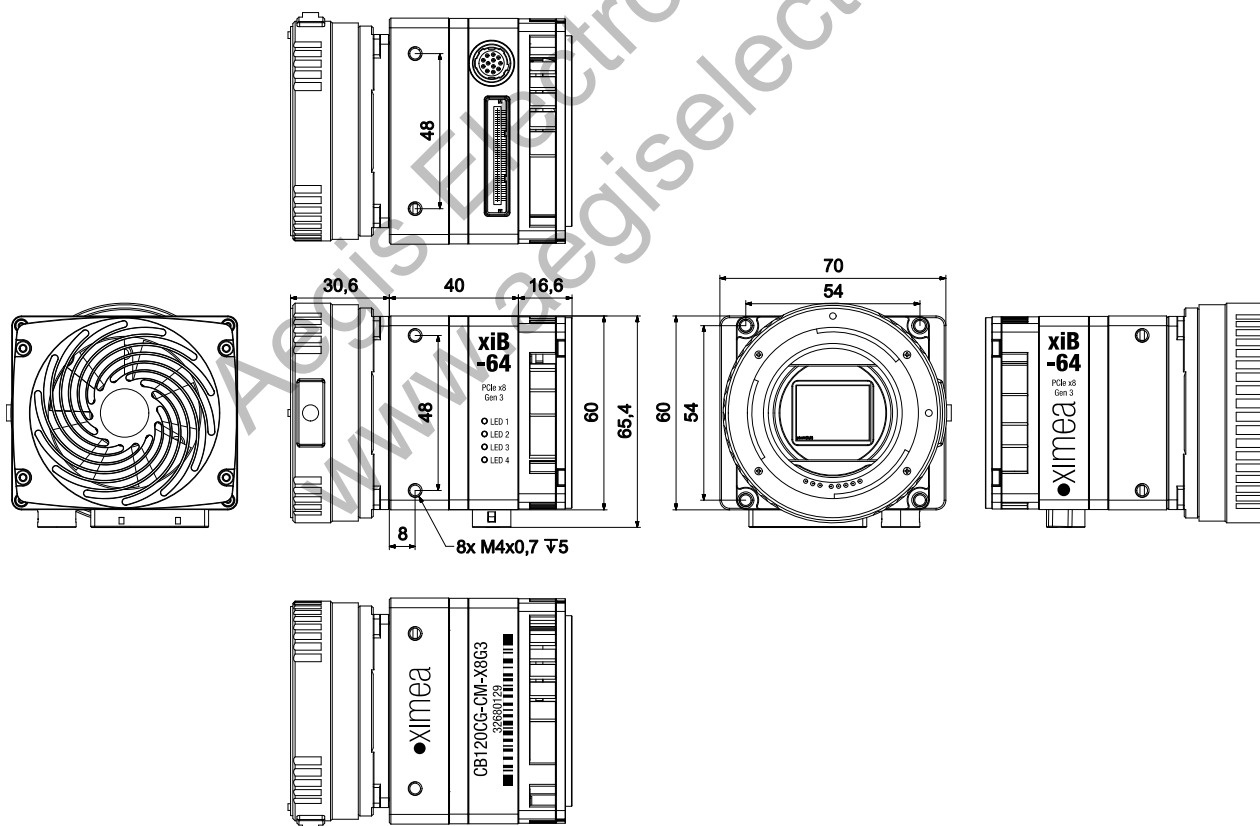

figure 3-21, dimensional drawing CB120xG-CM-X8G3 with EF-mount adapter and fan cooler unit

3.6.6.4. Referenced documents

CMOSIS datasheet CMV12000 datasheet v2.11

3.6.6.5. Sensor features

feature	Note
Binning	Yes 2x2
Skipping	Yes 2x2
ROI	Vertical cropping results in increased read speed, horizontal reduces data transfer
HW Trigger	Trigger with overlap (see 4.4.2 Trigger controlled Acquisition/Exposure)
HDR	Not available

table 3-20, sensor features available

Aegis Electronic Group
www.aegiselect.com

3.6.7. CB160xG-LX-X8G3

3.6.7.1. Sensor and camera parameters

xiB-64 model	CB160CG-LX-X8G3	CB160MG-LX-X8G3
Sensor parameter		
Part number	LUX160C	LUX160M
Color filter	RGB Bayer mosaic	None
Type	Global shutter	
Pixel Resolution (W x H) [pixel]	4704 × 3424	
Active area size (W x H) [mm]	18.35 × 13.35	
Sensor diagonal [mm]	22.7	
Optical format [inch]	4/3"	
Pixel Size [μm]	3.9	
ADC resolution [bit]	10	
FWC [ke-]	10	
Dynamic range [dB]	60	
SNR Max [dB]	40	
Conversion gain [e-/LSB ₁₂]	TBD	
Dark noise [e-]	10	
Dark current [e-/s]	TBD	
DSNU [e-]	33	
PRNU [%]	<2	
Linearity [%]	TBD	
Shutter efficiency	TBD	
Micro lenses	YES	
Camera parameters		
Digitization [bit]	10	
Supported bit resolutions [bit/pixel]	8, 9, 10, 11, 12, 16	
Exposure time (EXP) [ms]	0.001 – 1000	
Variable Gain Range (VGA) [dB]	0-18dB	
Refresh rate (MRR) [fps]	311 (10-bit)	
Power consumption		
Typical [W]	13.4(25.6) ¹	
Maximum [W]	17.6(27.0) ¹	
Mechanical		
height [mm]	60	
width [mm]	70	
depth [mm]	41 (w/o EF-mount adapter and active cooling)	
mass [g]	268 (w/o EF-mount adapter and active cooling)	

table 3-21, CB160xG-LX-X8G3, sensor and camera parameters

Notes: 1) Hardware revision 2 power consumption in brackets. Produced till Q3/2019

Binning/skipping	Output resolution	Bit/px	fps	Readout time [ms]
1x1/1x1	4704 × 3424	8(10)	311	3.02

table 3-22, CB160xG-LX-X8G3, standard readout modes

3.6.7.2. Quantum efficiency curves [%]

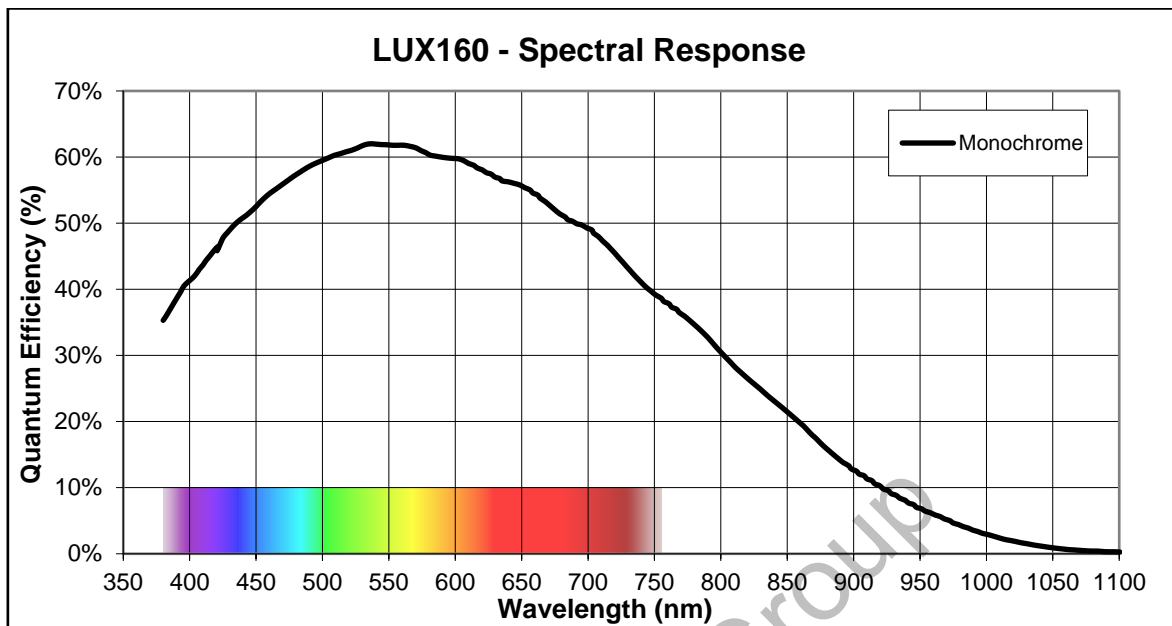

figure 3-22, LUX160 quantum efficiency chart ©Luxima

Aegis Electronic Group
www.aegiselect.com

3.6.7.3. Dimensional drawings CB160xG-LX-X8G3

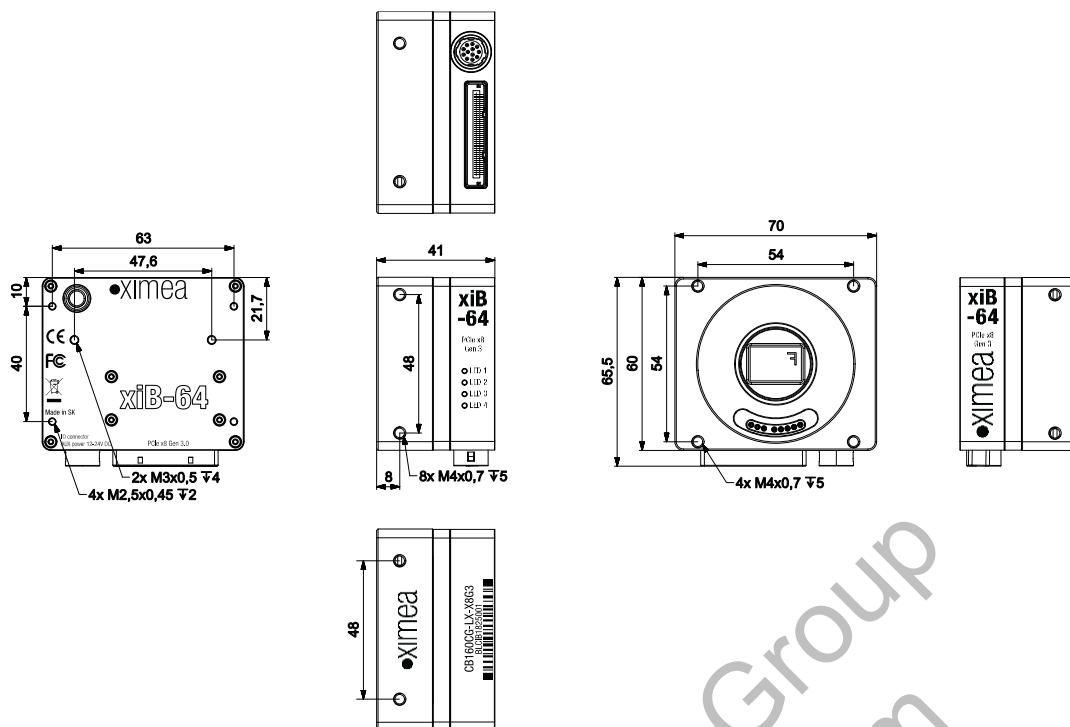

figure 3-23, dimensional drawing CB160xG-LX-X8G3 without EF-mount adapter

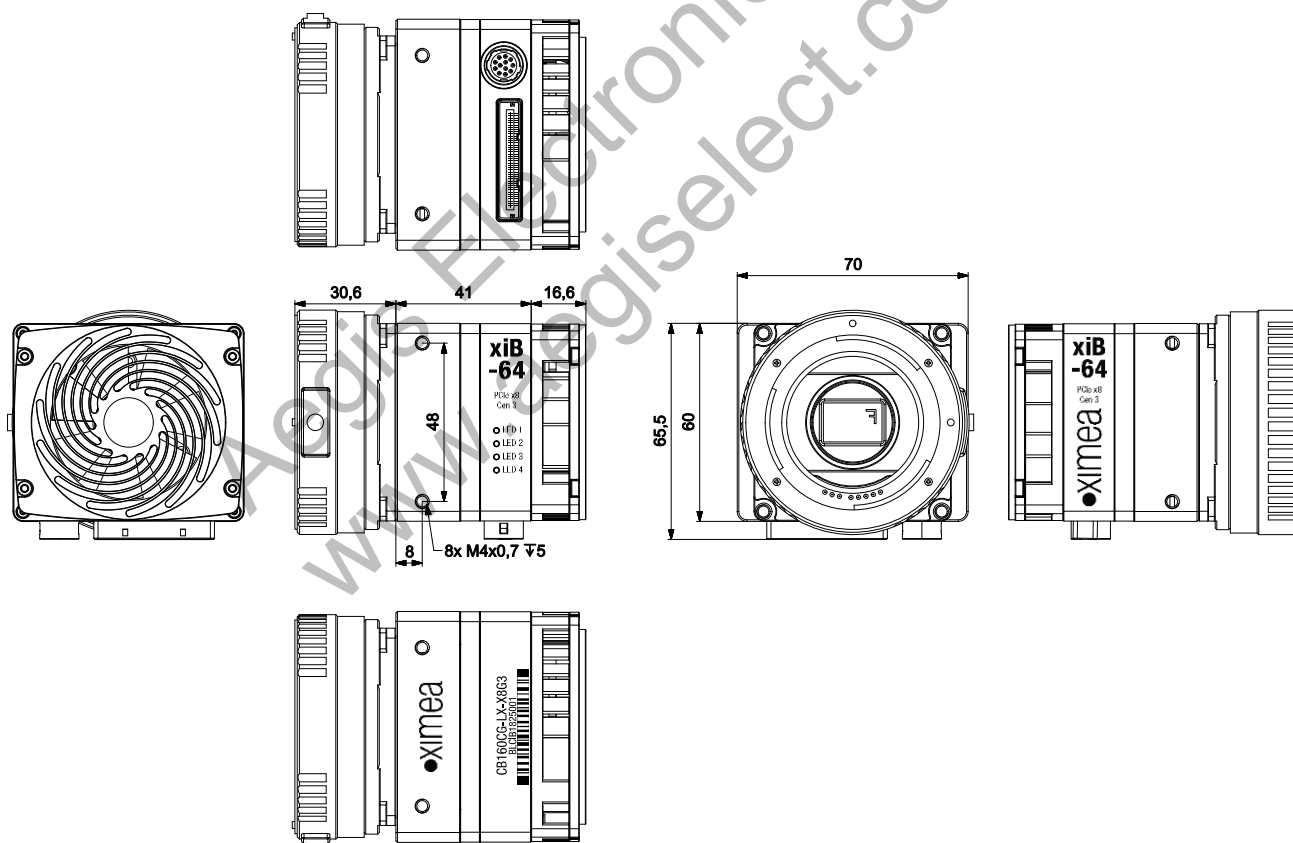

figure 3-24, dimensional drawing CB160xG-LX-X8G3 with EF-mount adapter and fan cooler unit

3.6.7.4. Referenced documents

Luxima Datasheet LUX160_Datasheet_V2.4

3.6.7.5. Sensor features

feature	Note
Binning	No
Skipping	No
ROI	Vertical cropping results in increased read speed, horizontal reduces data transfer
HW Trigger	Trigger with overlap usable (see 4.4.2 Trigger controlled Acquisition/Exposure)
HDR	Not available

table 3-23, sensor features available

Aegis Electronic Group
www.aegiselect.com

3.6.8. CB262xG-GP-X8G3

3.6.8.1. Sensor and camera parameters

xiB-64 model	CB262CG-GP-X8G3	CB262MG-GP-X8G3	CB262RG-GP-X8G3
Sensor parameter			
Part number	GMAX0505-DVC HLT	GMAX0505-DVM HLT	GMAX0505RF-DNM HLT
Color filter	RGB Bayer mosaic	None	None
Type	Global shutter		
Pixel Resolution (W x H) [pixel]	5120 × 5120		
Active area size (W x H) [mm]	12.8 × 12.8		
Sensor diagonal [mm]	18.1		
Optical format [inch]	1.1"		
Pixel Size [µm]	2.5		
ADC resolution [bit]	10, 12		
Saturation capacity [ke-]	4.7 (12bit) / 4.5 (10bit)		
Dynamic range [dB]	63.4 (12bit) / 60.6 (10bit)		
SNR Max [dB]	37.4		
Conversion gain [e-/LSB ₁₂]	1.22		
Dark noise [e-]	2.7 (12bit) / 3.7 (10bit)		
Dark current [e-/s]	4 (40°C)		
DSNU [e-]	1 @12bit		
PRNU [%]	<1		
Linearity [%]	<0.5		
Shutter efficiency	TBD		
Micro lenses	YES		
Camera parameters			
Digitization [bit]	10, 12		
Supported bit resolutions [bit/pixel]	8, 9, 10, 11, 12, 16		
Exposure time (EXP) [ms]	0.1 – 1000		
Variable Gain Range (VGA) [dB]	0-12dB		
Refresh rate (MRR) [fps]	150 (10-bit)		
Power consumption			
Typical [W]	13.6		
Maximum [W]	14		
Mechanical			
height [mm]	60		
width [mm]	70		
depth [mm]	36.1 (w/o EF-mount adapter and active cooling)		
mass [g]	250 (w/o EF-mount adapter and active cooling)		

table 3-24, CB262xG-GP-X8G3, sensor and camera parameters

Binning/skipping	Output resolution	Sensor Bit/px	Transport Bit/px	fps	Readout time [ms]
1x1/1x1	5120 × 5120	12	12	41.8	23.6
1x1/1x1	5120 × 5120	10	10	150.2	6.65
1x1/1x1	5120 × 5120	10	8	150.2	6.65
1x1/1x2	5120 × 2560	10	8	298.7	3.35
1x1/1x4	5120 × 1280	10	8	590.4	1.69

table 3-25, CB262xG-GP-X8G3, standard readout modes

3.6.8.2. Quantum efficiency curves [%]

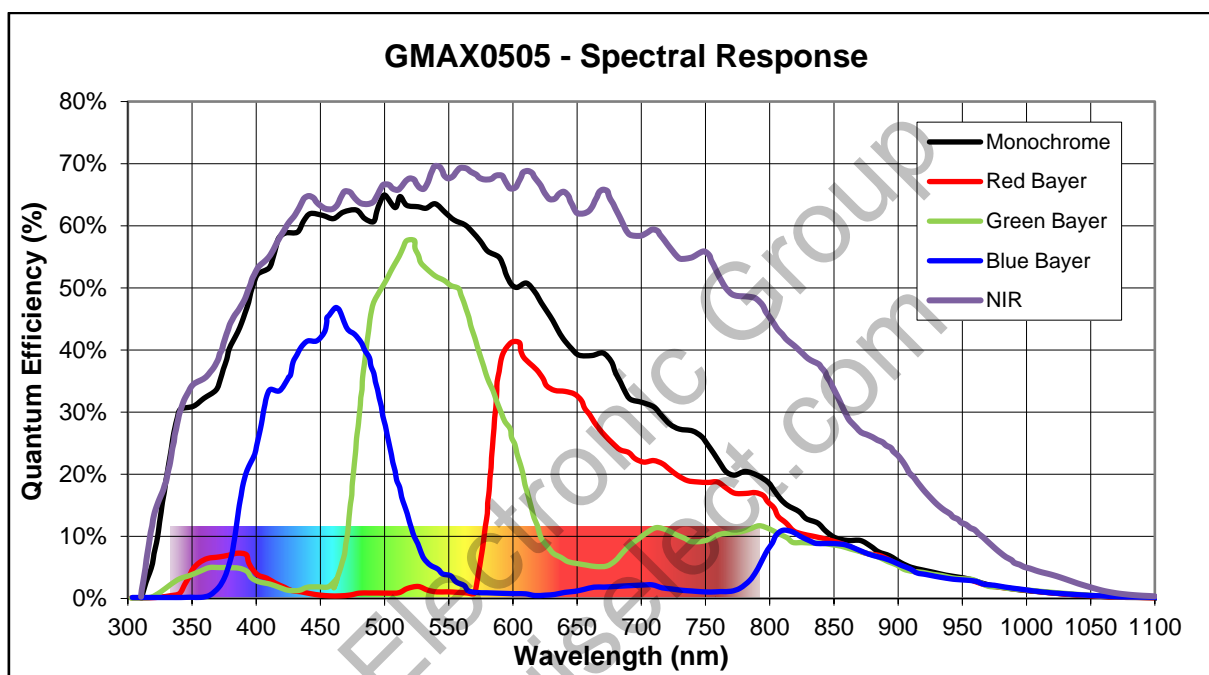

figure 3-25, GMAX0505 quantum efficiency chart ©Gpixel

3.6.8.3. Dimensional drawings CB262xG-GP-X8G3

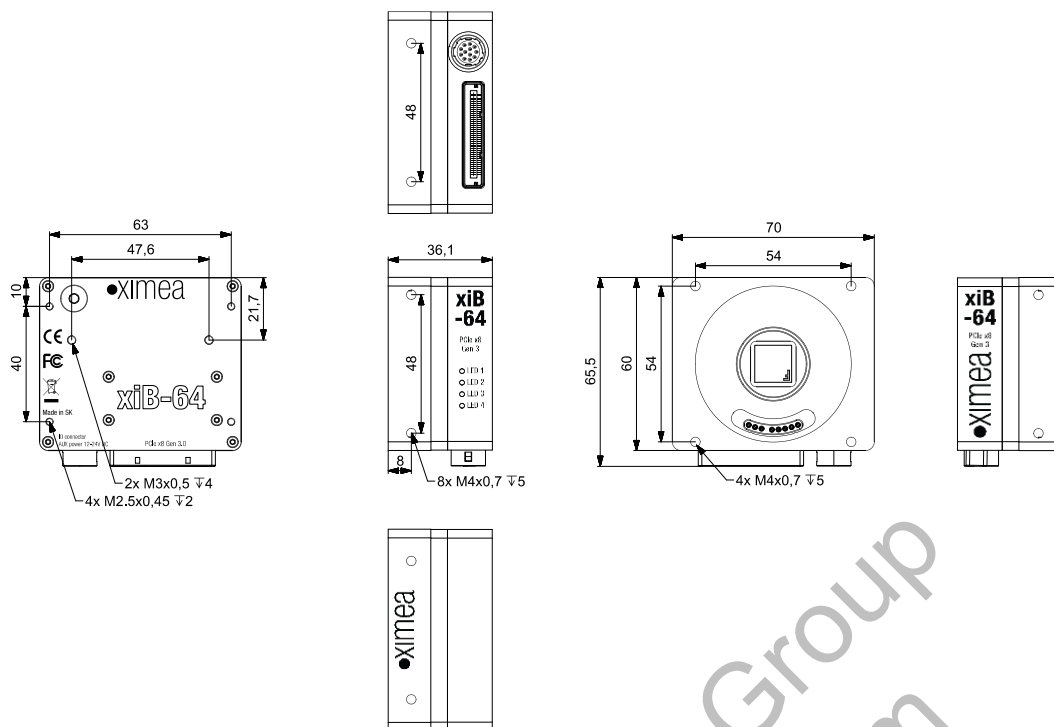

figure 3-26, dimensional drawing CB262xG-GP-X8G3 without EF-mount adapter

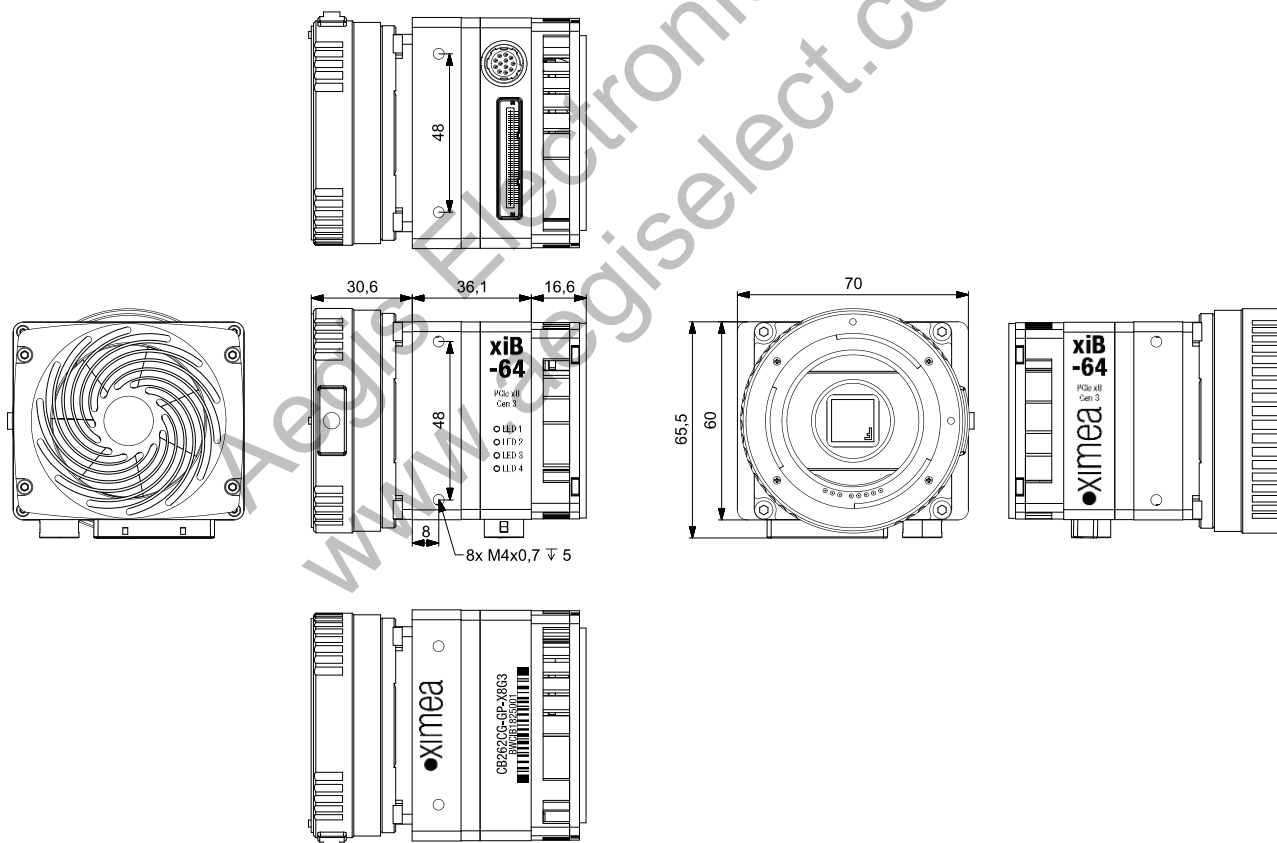

figure 3-27, dimensional drawing CB262xG-GP-X8G3 with EF-mount adapter and fan cooler unit

3.6.8.4. Referenced documents

Gpixel Datasheet GMAX0505_Datasheet_V1.2

3.6.8.5. Sensor features

feature	Note
Binning	No
Skipping	Vertical only 1-4
ROI	Vertical cropping results in increased read speed, horizontal reduces data transfer
HW Trigger	Trigger with overlap usable (see 4.4.2 Trigger controlled Acquisition/Exposure)
HDR	Not available

table 3-26, sensor features available

Aegis Electronic Group
www.aegiselect.com

3.6.9. CB654xG-GP-X8G3

3.6.9.1. Sensor and camera parameters

xiB-64 model	CB654CG-GP-X8G3	CB654MG-GP-X8G3
Sensor parameter		
Part number	GMAX3265-CC	GMAX3265-CM
Color filter	RGB Bayer mosaic	None
Type	Global shutter	
Pixel Resolution (W x H) [pixel]	9344 × 7000	
Active area size (W x H) [mm]	29.9 × 22.4	
Sensor diagonal [mm]	37.4	
Optical format [inch]	Almost full frame	
Pixel Size [μm]	3.2	
ADC resolution [bit]	10, 12	
FWC [ke-]	9.2	
Dynamic range [dB]	64.2 (12bit) / 61 (10bit)	
SNR Max [dB]	40	
Conversion gain [e-/LSB ₁₂]	2.63	
Dark noise [e-]	5.19 (12bit) / 7.68 (10bit)	
Dark current [e-/s]	2.2 (35°C)	
DSNU [e-]	2.26 @12bit	
PRNU [%]	<1 (12bit)	
Linearity [%]	<0.5	
Shutter efficiency	1/28000	
Micro lenses	YES	
Camera parameters		
Digitization [bit]	10, 12	
Supported bit resolutions [bit/pixel]	8, 9, 10, 11, 12, 16	
Exposure time (EXP) [ms]	0.100 – 1000	
Variable Gain Range (VGA) [dB]	0-12dB	
Refresh rate (MRR) [fps]	71.1 (10-bit)	
Power consumption		
Typical [W]	16.7	
Maximum [W]	17.3	
Mechanical		
height [mm]	60	
width [mm]	70	
depth [mm]	41.8 (w/o EF-mount adapter and active cooling)	
mass [g]	290 (w/o EF-mount adapter and active cooling)	

table 3-27, CB654xG-GP-X8G3, sensor and camera parameters

Binning/skipping	Output resolution	Sensor Bit/px	Transport Bit/px	fps	Readout time [ms]
1x1/1x1	9344 × 7000	12	12	31.6	31.64
1x1/1x1	9344 × 7000	10	10	71.1	14.06
1x1/1x1	9344 × 7000	10	8	71.1	14.06
1x1/1x2	9344 × 3500	10	8	141.6	7.06
1x1/1x4	9344 × 1750	10	8	280.8	3.54

table 3-28, CB654xG-GP-X8G3, standard readout modes

3.6.9.2. Quantum efficiency curves [%]

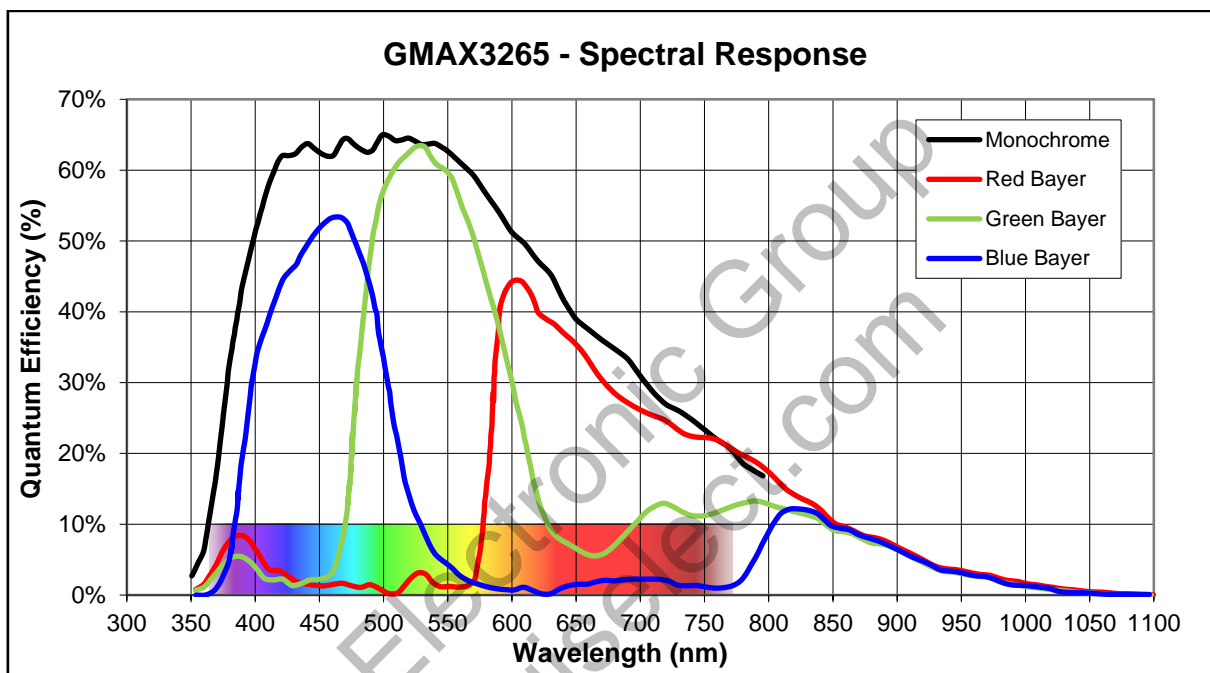

figure 3-28, GMAX3265 quantum efficiency chart ©Gpixel

3.6.9.3. Dimensional drawings CB654xG-GP-X8G3

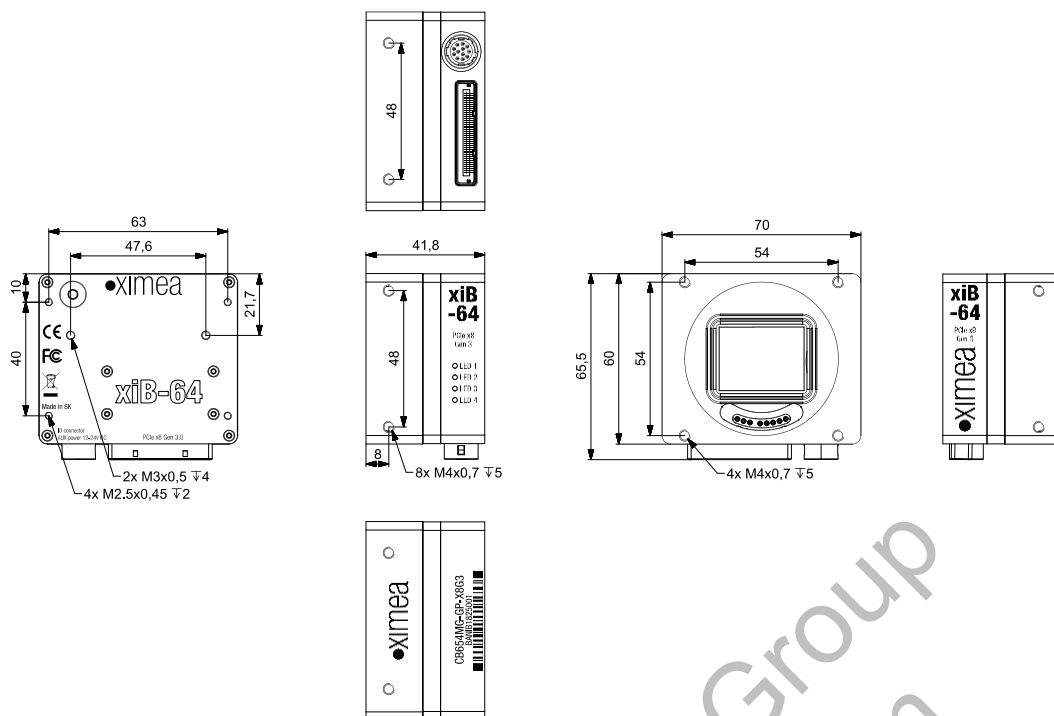

figure 3-29, dimensional drawing CB654xG-GP-X8G3 without EF-mount adapter

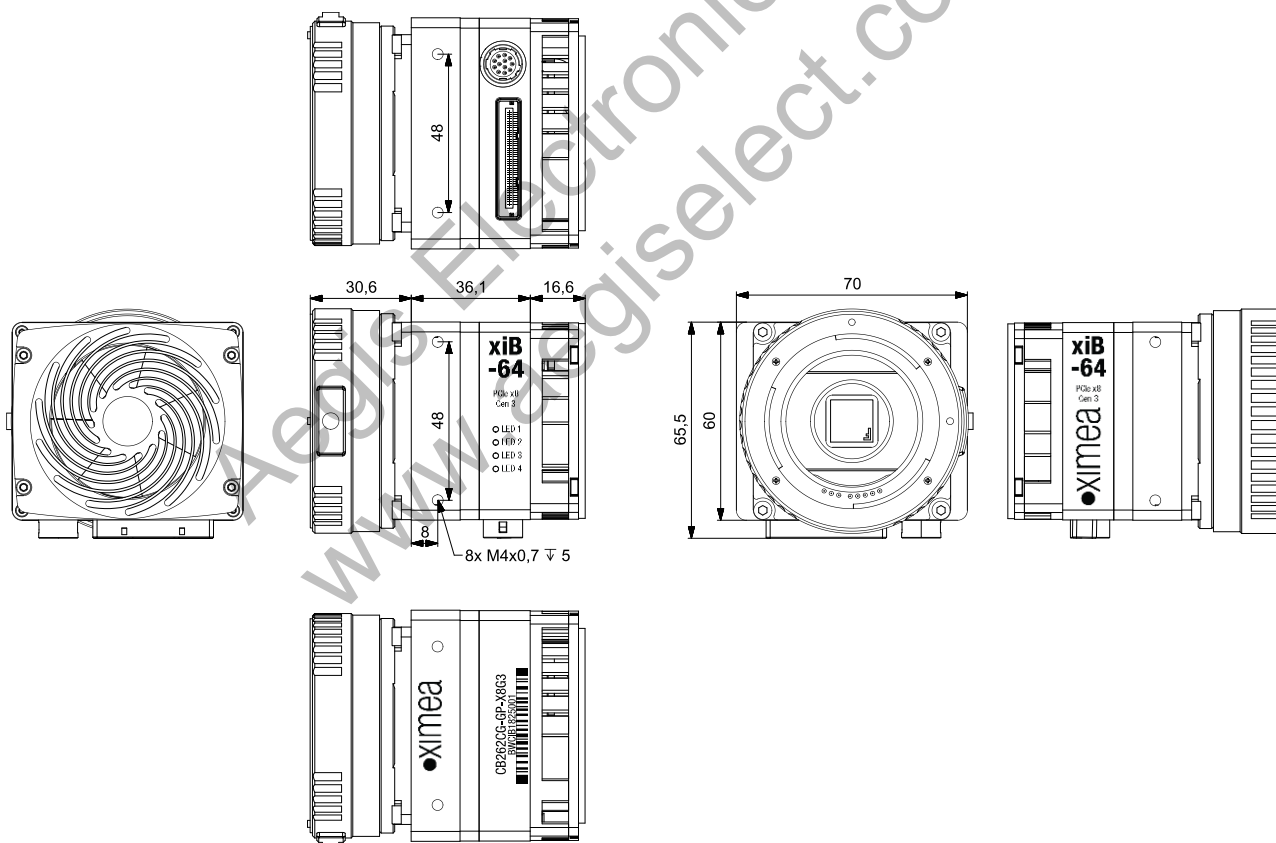

figure 3-30, dimensional drawing CB654xG-GP-X8G3 with EF-mount adapter and fan cooler unit

3.6.9.4. Referenced documents

Gpixel Datasheet GMAX3265_Datasheet_V1.0_20181212

3.6.9.5. Sensor features

feature	Note
Binning	No
Skipping	Vertical only 1-4
ROI	Vertical cropping results in increased read speed, horizontal reduces data transfer
HW Trigger	Trigger with overlap usable (see 4.4.2 Trigger controlled Acquisition/Exposure)
HDR	Not available

table 3-29, sensor features available

Aegis Electronic Group
www.aegiselect.com

3.7. User interface – LEDs

Four status LEDs are located on the back of the cameras, please see below.

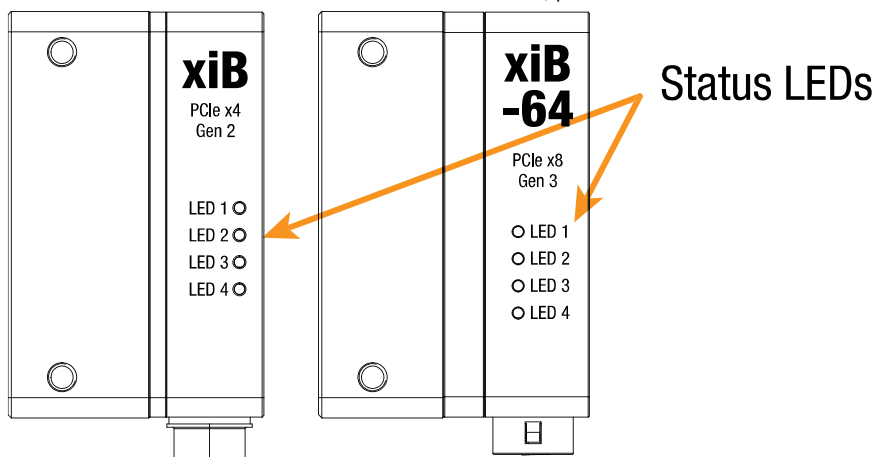

figure 3-31, position status LEDs

The LEDs are programmable. Please note the following description:

LED	Color	Defaults	Note
1	Green	On	User configurable
2	Red	Exposure active	User configurable
3	Blue	Frame active	User configurable
4	Orange	Off	User configurable

table 3-30, LED output description after camera is opened in API

After camera has been powered the LEDs are showing camera boot-up status or PCIe link status. The meaning differs between xiB and xiB-64 slightly.

Status	LED1 (Red)	LED2 (Green)	LED3 (Blue)	LED4 (Orange)
Off	Off	Off	Off	Off
Power	On	Off	Off	Off
Camera booted no PCIe	Off	Off	On	On
Golden firmware loaded ¹⁾	flash	flash	flash	flash
PCIe connected x4 Gen2	On	flash	flash	On
PCIe connected x4 Gen1	On	flash	flash	flash
PCIe connected x2(x1) Gen2	flash	flash	flash	On
PCIe connected x2(x1) Gen1 ¹⁾	flash	flash .	flash	flash

table 3-31, LED output description during xiB camera power up

Status	LED1 (Red)	LED2 (Green)	LED3 (Blue)	LED4 (Orange)
Off	Off	Off	Off	Off
Power	On	Off	Off	Off
Camera booted no PCIe	Off	Off	On	On
Golden firmware loaded ¹⁾	flash	flash	flash	flash
PCIe connected X8 Gen3	On	flash	flash	On
PCIe connected X8 Gen2(Gen1)	On	flash	flash	flash
PCIe connected x4(X2 or X1) Gen3	flash	flash	flash	On
PCIe connected x4(X2 or X1) Gen2(Gen1) ¹⁾	flash	flash	flash	flash

table 3-32, LED output description during xiB-64 camera power up

Notes:

1) To identify, if the golden firmware is loaded, please start xiCOP. See: [5.8 XIMEA Control Panel](#)

3.8. xiB, xiB-64 PCIe Interface

Camera family	Connector	Signals	Mating parts
xiB	Molex - 75586-0010	PCI express	Cable assembly from Molex, Samtec
xiB-64	Molex - 75586-0002	PCI express	Cable assembly from Molex, Samtec

table 3-33, PCI express mating connector description

The iPass™ connector is used for high speed data transmission.

Please note that many computers do not initialize PCIe buses that do not have devices plugged in upon boot. The camera needs to be plugged in with power when the computer is booted up before use.

3.8.1. iPass™ Connector Location

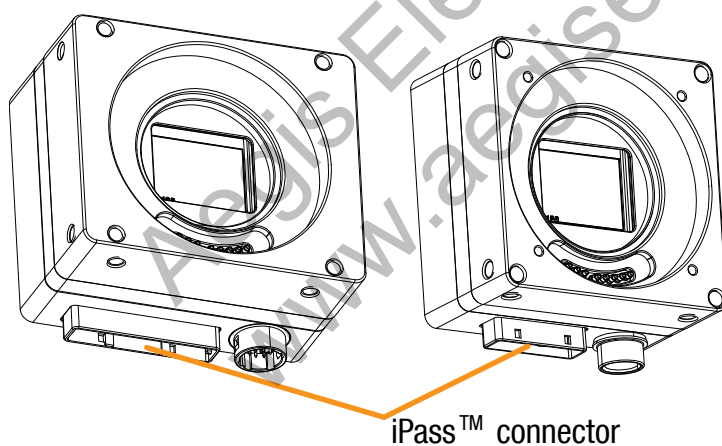

figure 3-32, position iPass™ connector



It is important that the power is turned off when inserting/detaching the cable. General ESD precautions need to be applied. Failing this requirement may lead to camera damage.

3.9. Digital Input / Output (GPIO) Interface and Power

PCIe xiB & xiB-64 cameras use the 12-pin connector for the GPIO interface and power. There are several input and output lines (both optically isolated and non-isolated). The xiB and xiB-64 do not use the same connector (though both are 12-pin).

Connector	Signals	Mating Connectors
xiB I/O & Power 12-pin Hirose HR25-9TR-12SA(71)	Opto-isolated trigger input and non-isolated I/O plus camera power	Hirose HR25-9TP-12P (connector on cable side) Ximea PN: CBL-CB-PWR-SYNC-3M0 for 3m cable
xiB-64 I/O & Power 12-pin Alysium 60-30-1112	Opto-isolated trigger input and non-isolated I/O plus camera power	Alysium 60-41-1012, 60-41-1112, 60-01-1012, 60-01-1112, 60-03-1012, 60-03-1112 Ximea PN: CBL-MT-PWR-SYNC-3M0 for 3m cable

table 3-34, GPIO mating connector description

3.9.1. Location

IO and power interface receptacle is located on the underside of the camera:

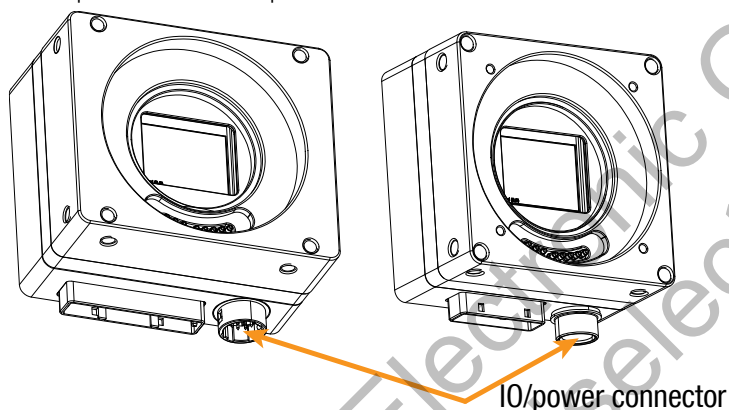

figure 3-33, position GPIO + power connector



It is important that the power is turned off when inserting/detaching the cable. General ESD precautions need to be applied. Failing this requirement may lead to camera damage.

3.9.2. IO Connector Pinning

xiB

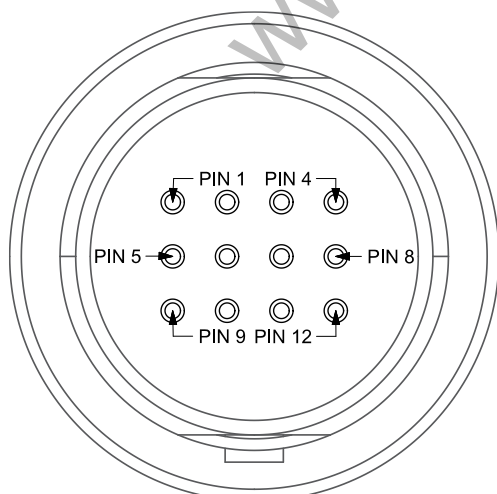

figure 3-34, xiB IO connector pinout

I/O connector Pin Assignment:

Pin	Name	Signal	Technical description
1	GND	External grounds for power and non-isolated I/O	
2	AUX PWR	Power supply input	12-24V
3	IN1	Opto-isolated Input 1	(<0.8 Low; 4-24 High)
4	IN2	Opto-isolated Input 2	(<0.8 Low; 4-24 High)
5	IN GND	Ground for Opto-Isolated Inputs (IN1, IN2)	
6	INOUT1	Non-isolated I/O	LVTTL(3.3, 50µA)
7	INOUT2	Non-isolated I/O	LVTTL(3.3, 50µA)
8	OUT1	Opto- isolated Output 1	Open collector
9	OUT2	Opto- isolated Output 2	Open collector
10	OUT GND	Ground for Opto-Isolated Out (OUT1, OUT2)	
11	INOUT3	Non-isolated I/O	LVTTL(3.3, 50µA)
12	INOUT4	Non-isolated I/O	LVTTL(3.3, 50µA)

table 3-35, xiB I/O connector Pin Assignment

xiB-64

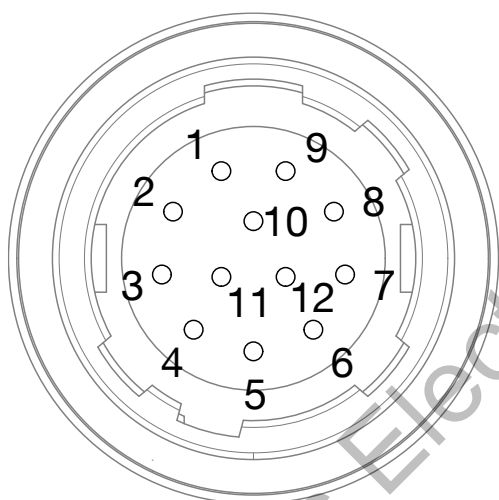

figure 3-35, xiB-64 IO connector pinout

I/O connector Pin Assignment:

Pin	Name	Signal	Technical description
1	IN2	Opto-isolated Input 2	(<0.8 Low; 4-24 High)
2	IN1	Opto-isolated Input 1	(<0.8 Low; 4-24 High)
3	OUT2	Opto-isolated Output 2	Open collector
4	OUT1	Opto-isolated Output 1	Open collector
5	AUX PWR	Power supply input	12-24V
6	GND	External grounds for power and non-isolated I/O	
7	INOUT1	Non-isolated I/O	LVTTL(3.3, 50µA)
8	INOUT3	Non-isolated I/O	LVTTL(3.3, 50µA)
9	INOUT2	Non-isolated I/O	LVTTL(3.3, 50µA)
10	IN GND	Ground for Opto-Isolated Inputs (IN1, IN2)	
11	OUT GND	Ground for Opto-Isolated Out (OUT1, OUT2)	
12	INOUT4	Non-isolated I/O	LVTTL(3.3, 50µA)

table 3-36, xiB-64 I/O connector Pin Assignment

Signal	Description	GPI/GPO index API
IN1	Opto-isolated Input	1/-
IN2	Opto-isolated Input	2/-
OUT2	Opto- isolated Output	-/1
OUT2	Opto- isolated Output	-/2
INOUT1	Non-isolated I/O	3/3
INOUT2	Non-isolated I/O	4/4
INOUT3	Non-isolated I/O	5/5
INOUT4	Non-isolated I/O	6/6

table 3-37, xiB and xiB-64 IO pin to API index assignment

It is recommended using twisted pair cables for both xiB & xiB-64 IOs. Each input and output should be twisted with its respective ground.

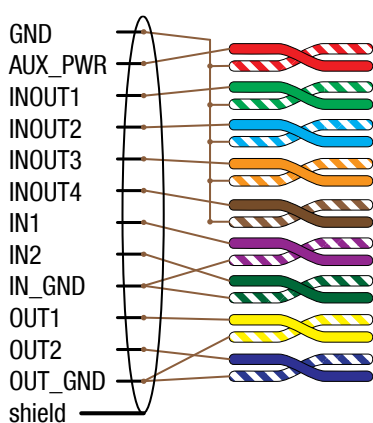

figure 3-36 Recommended twisted pair configuration, xiB

3.9.3. Power input

The cameras require a DC input of +12 to +24V with a maximum of about 29W without lens control. Ximea offers a power supply which can plug into the CBL-CB-PWR-SYNC-3M0 or CBL-MT-PWR-SYNC-3M0 (power/sync cable) and provide DC power to the camera from an AC 120V-230V source. Recommended power supply for xiB cameras is 30W or more and minimum 60W for xiB-64.

3.9.4. Optically isolated Digital Input

3.9.4.1. Optically isolated Digital Input - General info

Item	Parameter / note
Maximal input voltage	24V
Common pole	No
Effect of incorrect input terminal connection	Reverse voltage polarity protected
Effects when withdrawing/inserting input module under power	No damage, no lost data
Maximum recommended cable length	5m
Input level for logical 0	Voltage < 2.0V/Current 0mA to 0.3mA
Input level for logical 1	Voltage > 4.0V/Current 4mA to 6mA
Input debounce filter	No
Input delay – rising edge	1.7 +/-0.2µs (V _{INPUT} =10V, T _{AMBIENT} =25°C)
Input delay – falling edge ¹	10.7 +/-0.2µs (V _{INPUT} =10V, T _{AMBIENT} =25°C)
Number of inputs	1
External trigger mapping	Yes
Input functions	Trigger, get current level (rising or falling edge are supported)

table 3-38, Optically isolated digital input, general info

Note: – 1) Propagation delay depends on voltage level, propagation jitter is significantly lower.

3.9.4.2. Digital Input – signal levels

Input levels are not IEC 61131-2, Type 1 as the ON state has been extended to support 5V TTL

V-in-min [V]	V-in-max [V]	State	I-max [mA]
-24.0	2.0	Off (0)	0.0 – 0.3 mA (0mA nominal)
2.0	4.0	Transient	4
4.0	24.0	On (1)	4 – 6 mA (5mA nominal)

table 3-39, digital info, signal levels

Note:

- Input level **V_{in}** represents amplitude of the input signal.
- Voltage levels referenced to common ground GND

3.9.4.3. Digital Input – Internal Schematic

The internal scheme of Digital Input signal flow inside the camera is below.

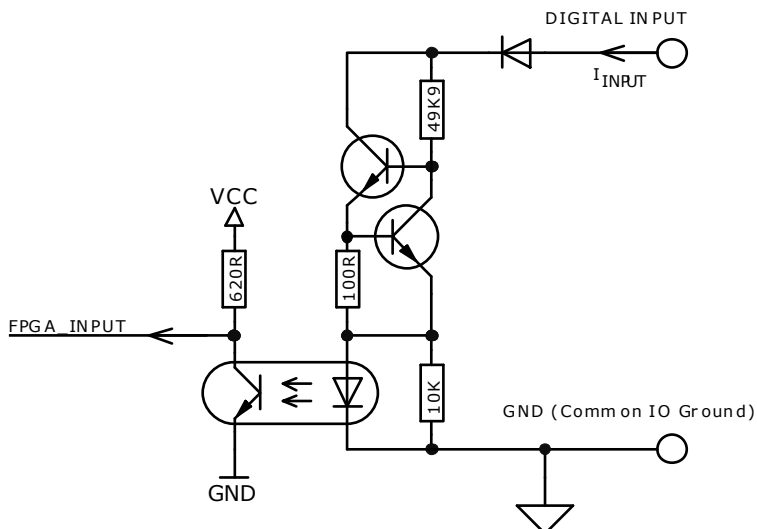

figure 3-37, digital input, interface schematic

3.9.4.4. Digital Input – Wiring

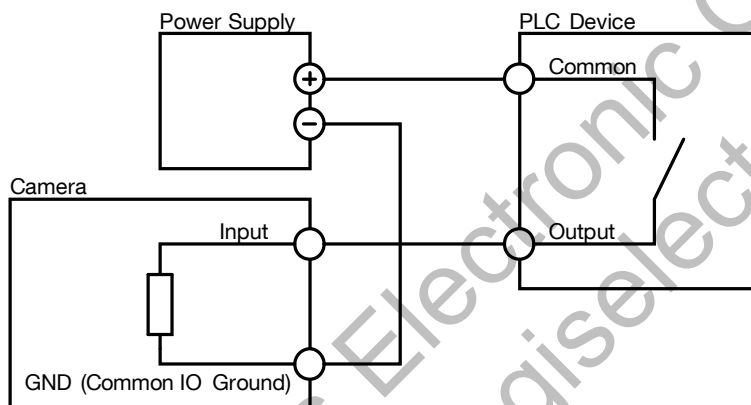

figure 3-38, digital input, interface wiring

3.9.4.5. Digital Input – Timing

Typical measured input delay between Digital Input to FPGA Input
Measurements of input delays:

Edge Type	Input Voltage [V]	Typ. delay [μ s]
Rising	5	1.6
Rising	10	1.7
Falling	5	7.8
Falling	10	10.7
Falling	24	12.7

table 3-40, digital input, timing

Note: Measured at: Ambient Temperature 25°C

3.9.5. Optically isolated Digital Output

3.9.5.1. Optically isolated Digital Output - General info

Item	Parameter / note
Maximal open circuit voltage	24V
Output port type	Open collector NPN
Protection	short-circuit / over-current / Reverse voltage
Protection circuit	PTC Resettable Fuse
Maximal sink current	25mA
Trip current	50mA – self restarting when failure mode current disconnected
Inductive loads	No
Effect of incorrect output terminal connection	Protected against reverse voltage connection
Maximal output dropout	1.7V, sink current 25mA
Number of outputs	1
Strobe output mapping	Yes

table 3-41, Optically isolated digital output, general info

3.9.5.2. Optically isolated Digital Output Delay

Output current	OFF -> ON	ON -> OFF	Note
2mA	0.55 μ s	41 μ s	$V_{\text{OUTPUT}}=5\text{V}$, $T_{\text{AMBIENT}}=25^{\circ}\text{C}$
5mA	0.6 μ s	43 μ s	$V_{\text{OUTPUT}}=5\text{V}$, $T_{\text{AMBIENT}}=25^{\circ}\text{C}$
10mA	0.88 μ s	51 μ s	$V_{\text{OUTPUT}}=11\text{V}$, $T_{\text{AMBIENT}}=25^{\circ}\text{C}$
25mA	1.4 μ s	51 μ s	$V_{\text{OUTPUT}}=13\text{V}$, $T_{\text{AMBIENT}}=25^{\circ}\text{C}$

3.9.5.3. Optically isolated Digital Output – Internal schematic

Following scheme is the internal scheme of the Digital Output signal flow inside the camera.

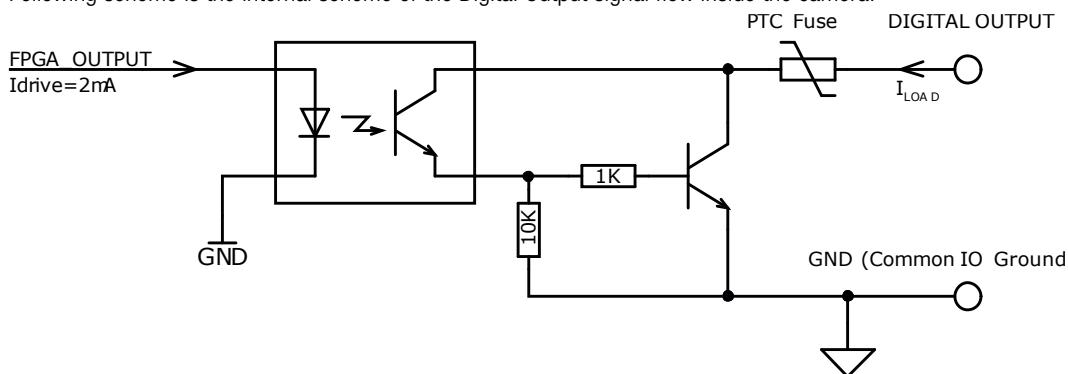

figure 3-39, digital output, interface schematic

Output Transfer Characteristic

When Output is in **On** state - typical transfer characteristic of output is as on following figure:

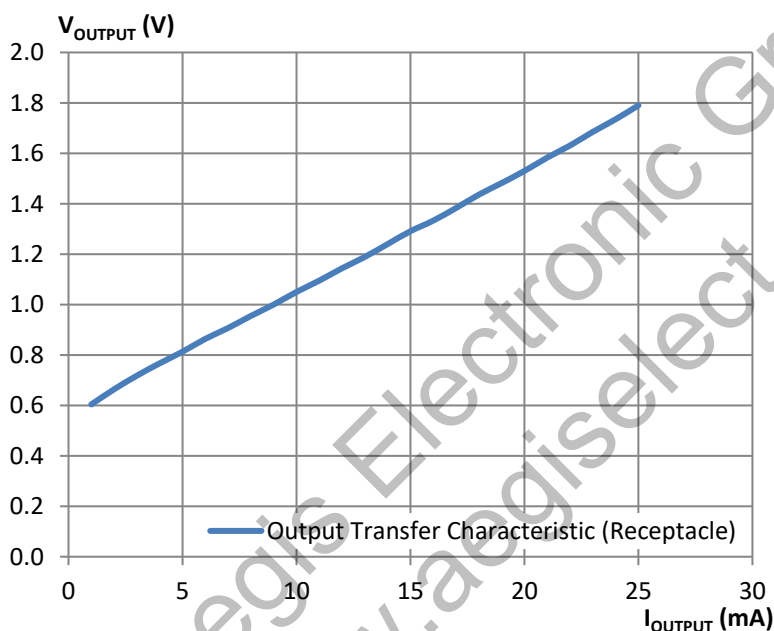

figure 3-40, digital output transfer characteristics

3.9.5.4. Digital Output – Wiring

Digital output has an open collector switching transistor with common IO Ground. In most cases a power source for external device must be provided.

3.9.5.4.1. Connecting Digital OUTPUT to a NPN-compatible PLC device input (biased)

Output state	Output switch state	Input state
ON	Sourcing current	Pull up (energized)
OFF	Relaxing	Not energized

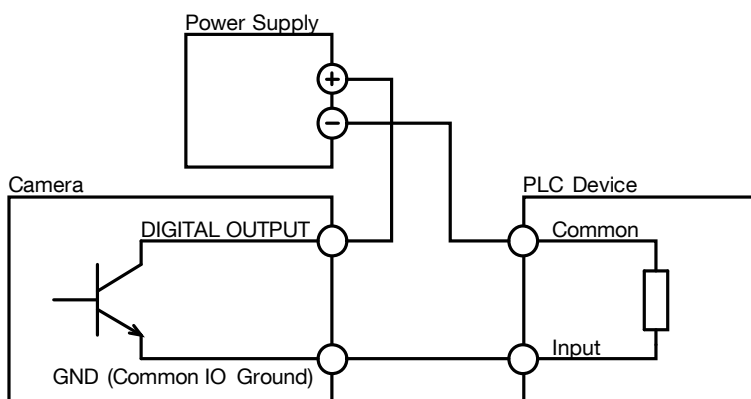

figure 3-41, Connecting Digital OUTPUT to a NPN-compatible PLC device input (biased)

Important note:

- If using this configuration, take into account that Common Ground connection may be biased by power supply for Digital Input!

3.9.5.4.2. Connecting Digital OUTPUT to a NPN-compatible PLC device input

This type of connection is possible only when opto-isolated input is used (bidirectional in some cases) or when only one general opto-isolated input is used.

Output state	Output switch state	Input state
ON	Sourcing current	Pull down (energized)
OFF	Relaxing	Not energized

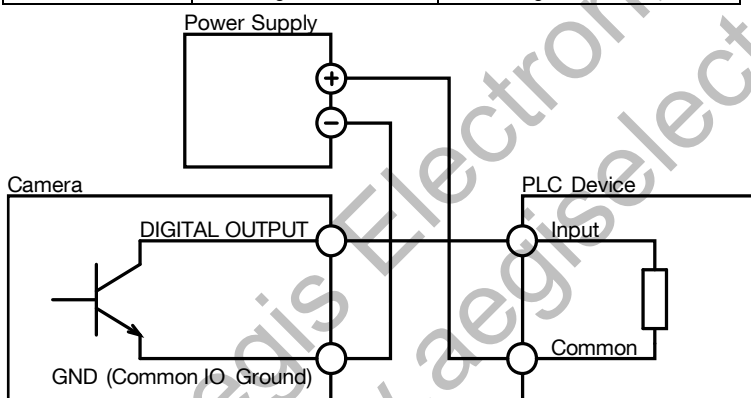

figure 3-42, Connecting Digital OUTPUT to a NPN-compatible PLC device input - more bidirectional inputs used

Note:

- In this case a bidirectional opto-isolated input must be used

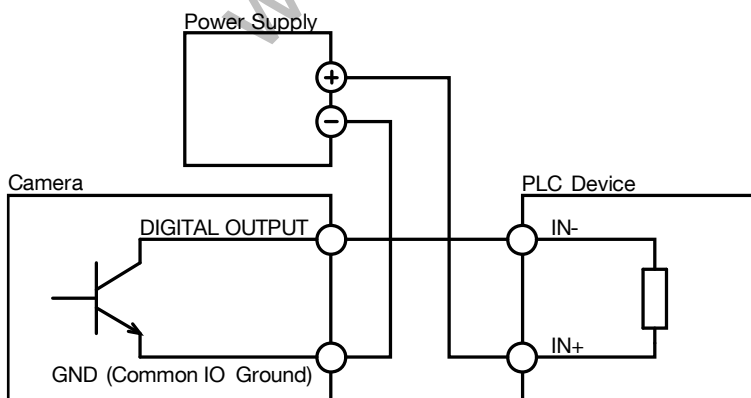

figure 3-43, Connecting Digital OUTPUT to a NPN-compatible PLC device - single input

3.9.5.4.3. Connecting Digital OUTPUT to a PNP-compatible device

Output state	Output switch state	Input state
ON	Sinking current	Not energized
OFF	Relaxing	Pull up (energized)

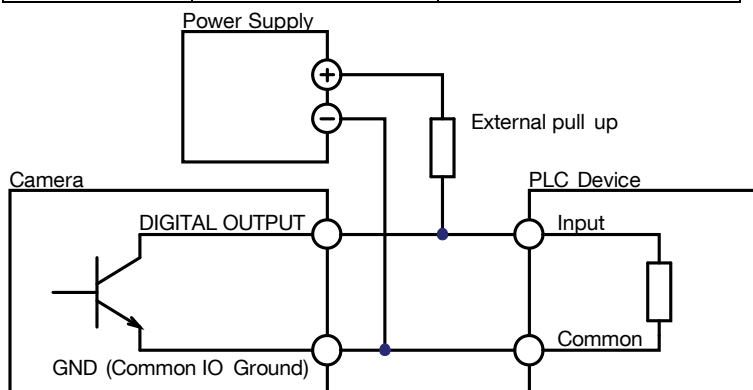

figure 3-44, Connecting Digital OUTPUT to a PNP-compatible device

Pull up resistor can be calculated as follows:
$$R = \frac{V_{psu} - V_{input}}{I_{input}}$$

Where:

V_{psu} power supply voltage. Must be higher than required input amplitude

V_{input} required input amplitude

I_{input} input driving current (corresponding to input amplitude)

Remember to use the appropriate resistor power rating $P(R) > (V_{psu} - V_{input}) * I_{input}$

3.9.5.4.4. Output Wiring Example: LED Driving

LED can be driven directly by camera digital output. A series resistor must be used to limit LED current.

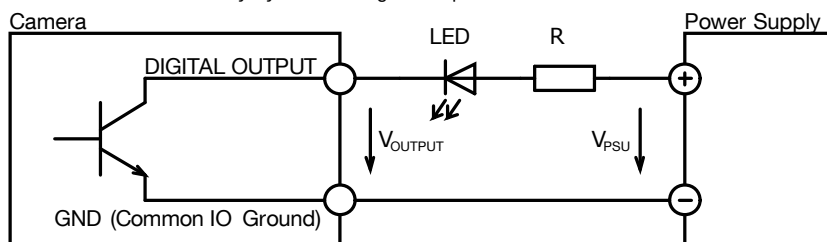

figure 3-45, LED Driving

LED series resistor can be calculated by the following equation: $R = \frac{V_{psu} - V_{output} - V_{led}}{I_{led}}$

Where:

V_{psu} power supply voltage (5V to 24V)

V_{output} voltage across digital output pins (see. [3.9.5.1 Optically isolated Digital Output - General info](#))

V_{led} LED forward voltage (see table below)

I_{led} LED current

Note:

- Remember to use the appropriate resistor power rating $P(RES) = I_{led}^2 \times R = (V_{psu} - V_{led}) \times I_{led}$

Typical LED forward voltage

LED Colour	V_{led} (typ.)	V_{led} (max.)	Note
Standard Red	1.7V	2.1V	
Super Bright Red	1.85V	2.5V	
Low power Red	1.7V	2.0V	
Orange	2.0V	2.1V	
Yellow	2.1V	2.2V	
Green	1.9V	2.5V	
Emerald Green	2.1V	2.7V	
Blue	2.5V	3.7V	
White	2.8V	3.8V	
Infra-Red	1.3V	1.8V	Opto coupler

table 3-42, digital output, LED driving

3.9.5.4.5. Output Wiring Example: Inductive load (Relay) Driving

Do not connect inductive load RL directly to Camera Digital Output. A transistor must be used to prevent damage of the output. See image below for possible inductive load driving. Resistor R can be connected to Digital Outputs and power supply to provide the necessary bias current for transistor. You should also use an external diode to protect the transistor from over voltage while disconnecting an inductive load. Keep in mind that this connection has an inverted logic. Current will flow through the load at the start of the camera.

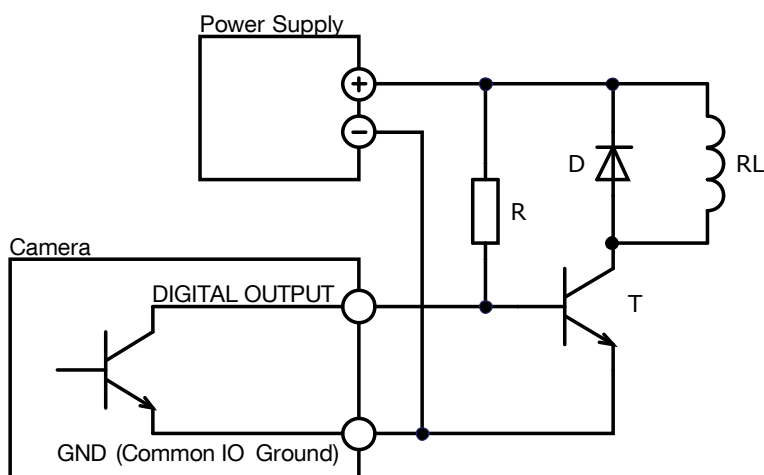

figure 3-46, Inductive load (Relay) Driving (inverted logic)

For positive logic you can use a second bipolar transistor.

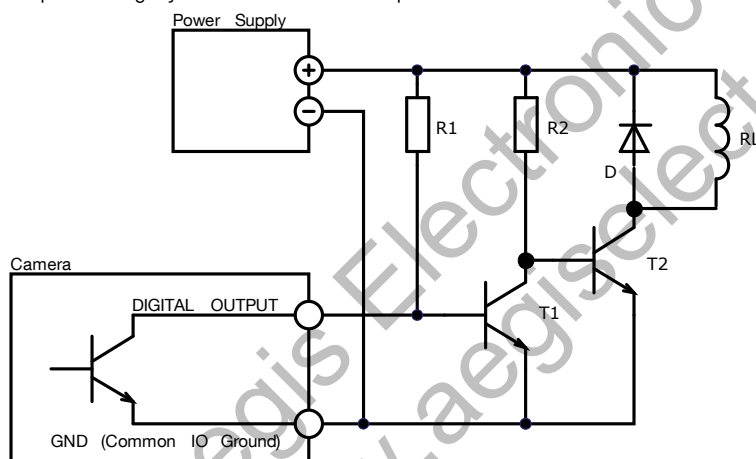

figure 3-47, Inductive load (Relay) Driving (non-inverted logic)

3.9.5.4.6. Output Wiring Example: Driving the trigger input of a strobe controller

The digital output can be used to drive a strobe controller according to the table below.

Driving the trigger input of a strobe controller

Trigger polarity	Opto-isolated controller input	Output delay	Wiring	Description
Positive edge	Yes	0.5µs	figure 3-41	
Negative edge	Yes	0.5µs	figure 3-43	
Positive edge	No	155µs	figure 3-44	Not recommended in cases when short delay time is required. Output delay is much longer than in other wiring examples. Use external pull up in case that no pull up at controller input is used.
Negative edge	No	0.5µs	figure 3-44	Note that external pull up is not used in this case. Assume that internal pull up at the controller input is used.

table 3-43, digital output, wiring examples

3.9.5.5. Digital Output – Timing

Typical input delay between FPGA Output to Digital Output

Edge Type	Typ. delay [µs]
Off -> On	0.5
On -> Off	155

table 3-44, digital output, typical timing

Note: Measured at conditions: $V_{OUTPUT}=18V$, $T_{AMBIENT}=27^{\circ}C$

Output delay depending on output current:

Output current	OFF->ON	ON->OFF
2mA	0.55µs	184µs
5mA	0.55µs	182µs
10mA	0.55µs	133µs
25mA	0.55µs	113µs

table 3-45, digital output, current depending timing

Note: Measured at conditions: $V_{OUTPUT}=11V$, $T_{AMBIENT}=25^{\circ}C$

3.9.6. Non-isolated Digital Lines

There is difference in non-isolated digital lines depending on hardware revision of the camera main PCA. You can check the revision in xiCOP. First two numbers of hw revision encode the main PCA revision. All revisions less or equal to 09 have Specification in chapter in following chapter. Specification of newer revision is in chapter [3.9.6.2](#)

3.9.6.1. Specification for Hardware revision ≤ 09

Non isolated Digital lines can be used as inputs or outputs compatible with TTL logic. These are high impedance pins so when used as output high impedance slave input has to be used.

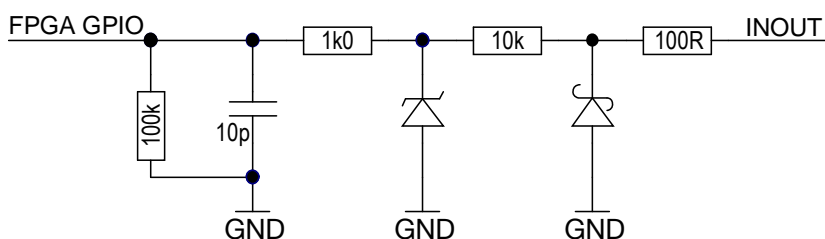

figure 3-48, non isolated input/output, interface schematic

Item	Parameter/note
Number of digital lines	4, each line can be configured by application separately as input or output
Maximum input voltage	24V DC
Common pole	Yes, AUX power GND
Effect of incorrect input terminal connection	Reverse voltage polarity protected
Effects when withdrawing/inserting input module under power	No damage, no lost data
Protection	Short-circuit/over-current/reverse voltage
Maximal output sink current	30 μ A, maximum advised load = 60k Ω
Inductive loads	No
Output level logical 0	<0.4V, Load 100k Ω
Output level logical 1	>2.5V, Load100k Ω
Output delay – rising edge	400ns, Load 100k Ω , threshold 2V
Output delay - falling edge	450ns, Load 100k Ω , threshold 0.5V
Input impedance – minimum	15k Ω
Input level for logical 0	<0.7V
Input level for logical 1	>3.3V
Input debounce filter	No
Input delay – rising edge	750ns, $V_{INPUT}=5V, T_{AMBIENT}=25^{\circ}C$
Input delay – falling edge ¹	1200ns, $V_{INPUT}=5V, T_{AMBIENT}=25^{\circ}C$
Input functions	Trigger, get current level; Rising or falling edge are supported for trigger
Output functions	Off, On, Exposure active, Frame active; Signal inversion supported

Table 3-46, General info for non-isolated digital in/out trigger lines.

NOTE 1) Because of low input impedance of non-isolated input it is not possible to connect master slave of two cameras directly. Signal conditioning (buffer, opamp...) is required

3.9.6.2. Specification for Hardware revision > 09

Non isolated Digital lines can be used as inputs or outputs compatible with TTL logic. These are high impedance pins so when used as output high impedance slave input has to be used.

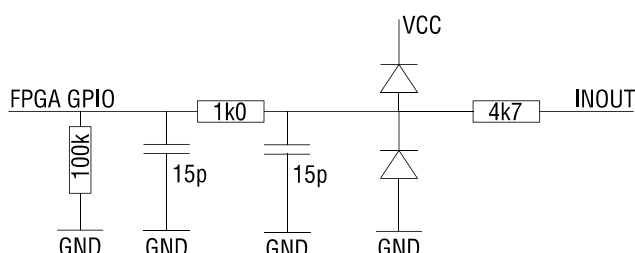

figure 3-49, non isolated input/output, interface schematic

Item	Parameter/note
Number of digital lines	4, each line can be configured by application separately as input or output
Maximum input voltage	24V DC
Common pole	Yes, AUX power GND
Effect of incorrect input terminal connection	Reverse voltage polarity protected
Effects when withdrawing/inserting input module under power	No damage, no lost data
Protection	Short-circuit/over-current/reverse voltage
Maximal output sink current	30 μ A, maximum advised load = 50k Ω
Inductive loads	No
Output level logical 0	<0.4V, Load 100k Ω
Output level logical 1	>2.8V, Load 100k Ω
Output delay – rising edge	150ns, Load 100k Ω /10pF, threshold 2V
Output delay - falling edge	300ns, Load 100k Ω /10pF, threshold 0.5V
Input impedance – minimum	20k Ω
Input level for logical 0	<0.7V
Input level for logical 1	>2.5V
Input debounce filter	No
Input delay – rising edge	250ns, $V_{INPUT}=5V, T_{AMBIENT}=25^{\circ}C$
Input delay – falling edge ¹	750ns, $V_{INPUT}=5V, T_{AMBIENT}=25^{\circ}C$
Input functions	Trigger, get current level; Rising or falling edge are supported for trigger
Output functions	Off, On, Exposure active, Frame active; Signal inversion supported

Table 3-47, General info for non-isolated digital in/out trigger lines.

NOTE 1) Because of low input impedance of non-isolated input it is not possible to connect master slave of two cameras directly. Signal conditioning (buffer, opamp...) is required

3.10. Power supply input (AUX PWR)

Item	Parameter/note
Supported voltage range	12-24V
Typical input current ¹	0.38A – 1.2A, @24V while acquiring
Maximum input current ¹	0.42A – 1.3A, @24V
Protection	Over/under voltage protection

table 3-48, digital output, typical timing

NOTE 1) Measured at conditions: $V=24V, T_{AMBIENT}=24^{\circ}C$ Power consumption is model dependent please refer to paragraph 3.6.

3.11. CBL-PCI-COP-xx/ CBL-PCI-FIB-xx

1.0m / 3.0m / 5.0m / 7.0m / 10m / 20m PCIe cables

Ximea offers a selection of different PCIe cables to interface the camera to the host computer. PCIe cables can be purchased in copper or fiber optic form. Longer lengths (up to 100m) can be achieved with the fiber optic option, since the copper cables are limited to 7.0m (to 3.0m for PCIe Gen 3). Both cables interface with a PCIe adapter board for your PC – see section 3.12. Get the latest information on available accessories at: <https://www.ximea.com/en/pci-express-camera/pci-express-camera-cmv12000-cmv20000>



figure 3-50, CBL-PEX4-COP-xM0 PCIe Gen.2 x4, copper cable



figure 3-51, CBL-PEX4-FIB-xM0, PCIe Gen.3 x4, fiber optics cable



figure 3-52, CBL-PEX8-FIB-xM0, PCIe Gen.3 x8, fiber optics cable

3.12. PCIe host adapter cards

Ximea offers several host adapter cards. Please check our website for the latest information on available cards for your PC.

https://www.ximea.com/support/wiki/xib/PCIe_host_adapters

Currently there are the following cards available.



figure 3-53 PEX4-G2-COP PCIe Gen.2 x4 extender host adapter for copper cables

PN	Description
PEX4-G2-COP	PCIe Gen.2 x4 extender host adapter for copper cables, 1 port
PEX4-G2-COP-X2	PCIe Gen.2 x4 extender host adapter for copper cables, 2 ports.
PEX4-G2-FIB	PCIe Gen.2 x4 extender host adapter for fiber optics cables, 1 port
PEX4-G2-FIB-X2	PCIe Gen.2 x4 extender host adapter for fiber optics and copper cables 2-Port
PEX4-G3-FIB-X2	PCIe Gen.3 x4 extender host adapter for fiber optics and copper cables 2-Port
PEX8-G3-X1-DOL	PCIe Gen.3 x8 extender host adapter for copper and fiber optics cables
PEX8-G3-X2-OSS	PCIe Gen.3 x8 dual port extender host adapter for copper and fiber optics cables

table 3-49, host adapter cards

3.13. CBL-CB-PWR-SYNC-3M0

The following is a description of the power/sync cable for the xiB camera line.

Get the latest information on available accessories at:

<https://www.ximea.com/en/pci-express-camera/pci-express-camera-cmv12000-cmv20000>

Cable drawing

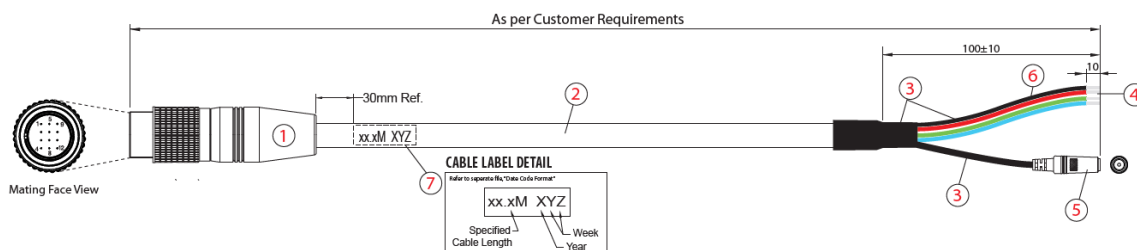

figure 3-54, drawing sync cable – current revisions of this cable are 3m in length

Cable components

Item	Description
1	65-00-1112 IO Series 65 12 pin male circular plug
2	A11-8861-UL20276 5STP#30 + 10C#30 [OD=5mm] Black
3	Heat shrinkable tube
4	Stripped and tinned leads
5	DC power in socket female (OD5.5/ID2.1) black
6	Shield wire
7	Cable label

table 3-50, sync + power cable, components

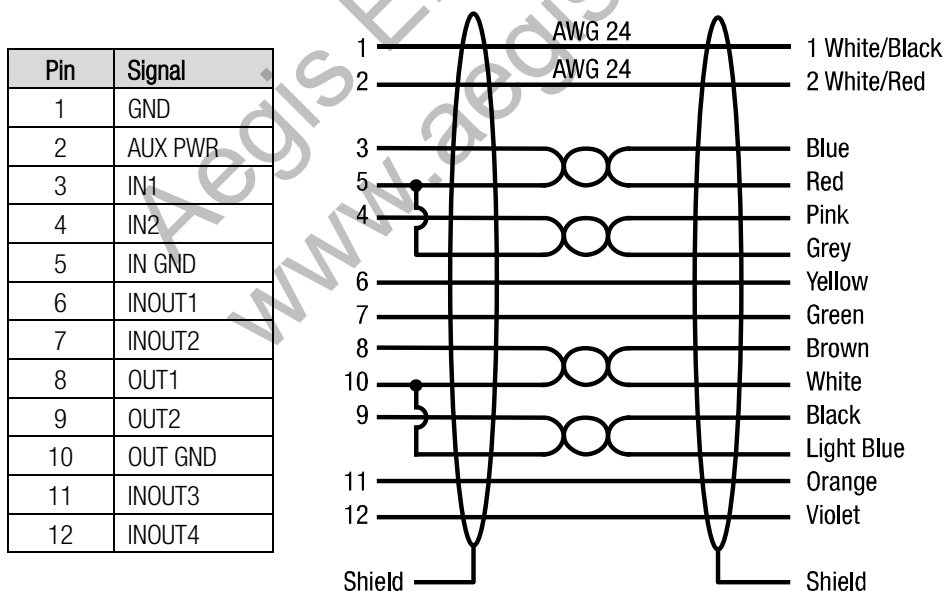

figure 3-55, wiring sync cable CBL-CB-POWER-SYNC-3M0

Pin	Signal
1	GND
2	AUX PWR
3	IN1
4	IN2
5	IN GND
6	INOUT1
7	INOUT2
8	OUT1
9	OUT2
10	OUT GND
11	INOUT3
12	INOUT4

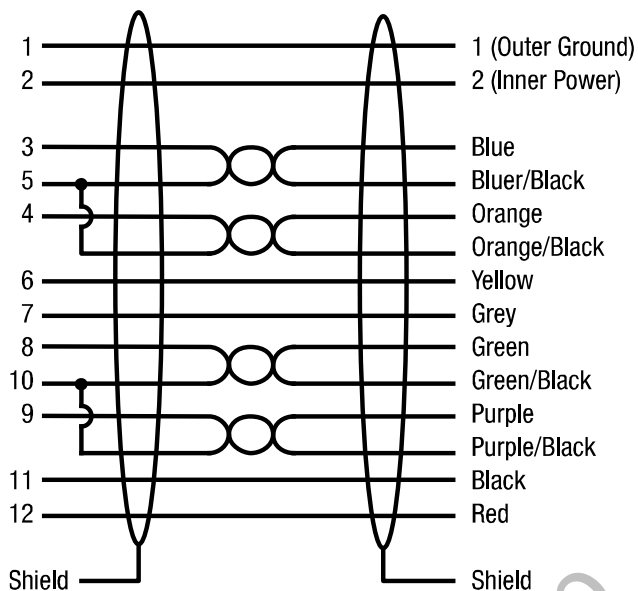

figure 3-56, wiring sync cable CBL-CB-POWER-SYNC-3M0 (legacy)

Aegis Electronic Group
 www.aegiselect.com

3.14. CBL-MT-PWR-SYNC-3M0

The following is a description of the xiB-64 sync/power cable.

Get the latest information on available accessories at:

<https://www.ximea.com/en/pci-express-camera/pci-express-camera-cmv12000-cmv20000>

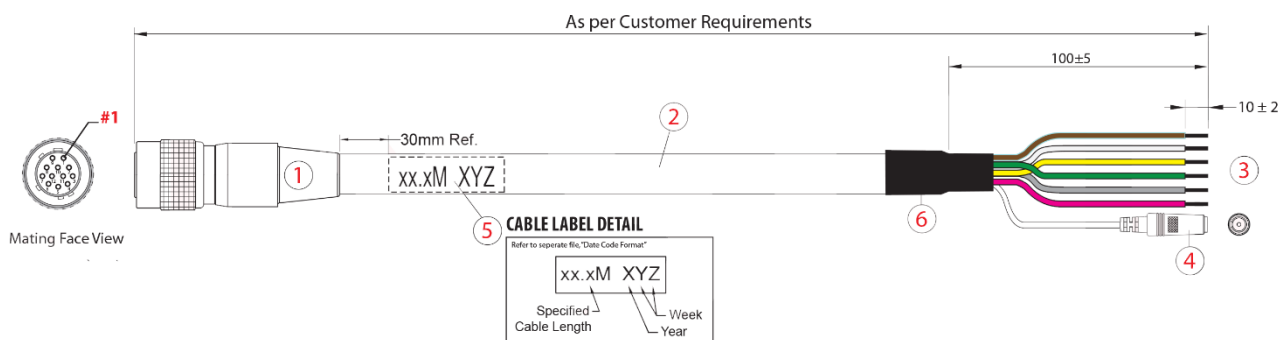

figure 3-57 drawing sync cable, current revisions of this cable are 3m in length

Item	Description
1	Series60 Female Circular Plug 60-01-1112 IO <BLK>
2	TBA UL20276 4STP#28 + 4C#28 + 2C#24 [OD=6.80mm] <BLK>
3	Process end with wire end stripped and tin soldered
4	DC power in socket female (OD5.5/ID2.1) <BLK>
5	Cable label
6	Heat shrinkable tube

table 3-51, sync + power cable, components

Pin	Signal
1	IN2
2	IN1
3	OUT2
4	OUT1
5	AUX PWR
6	GND
7	INOUT1
8	INOUT3
9	INOUT2
10	IN GND
11	OUT GND
12	INOUT4

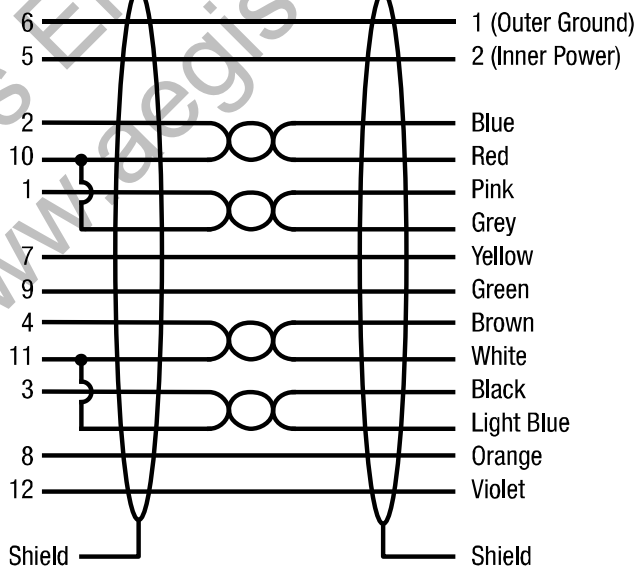

figure 3-58 Wiring diagram CBL-MT-POWER-SYNC-3M0

3.15. Tripod Adapter – MECH-60MM-BRACKET-T

Get the latest information on available accessories at:

xiB & xiB-64 series tripod mounting bracket

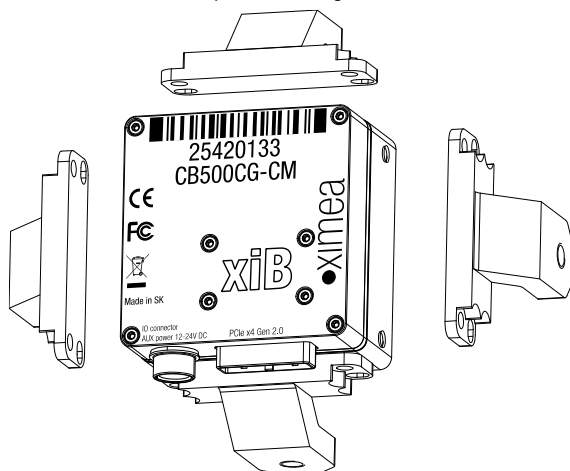

figure 3-59, mounting tripod adapter

Use 2x M4 screws provided with bracket as a kit for mounting. Bracket can be mounted on the bottom, top and sides of the camera.

Aegis Electronic Group
www.aegiselect.com

3.16. xiB-64 cooling – CB-X8G3-FAN-COOLER-KIT

xiB-64 need to have proper cooling. Fan cooling element can be provided along with camera.

Using hex 2.0 screw driver and 4 M2.5x14 can be attached or detached. When removing or inserting fan assembly please take care not to damage spring pins used to connect the cooling unit to camera electronics.

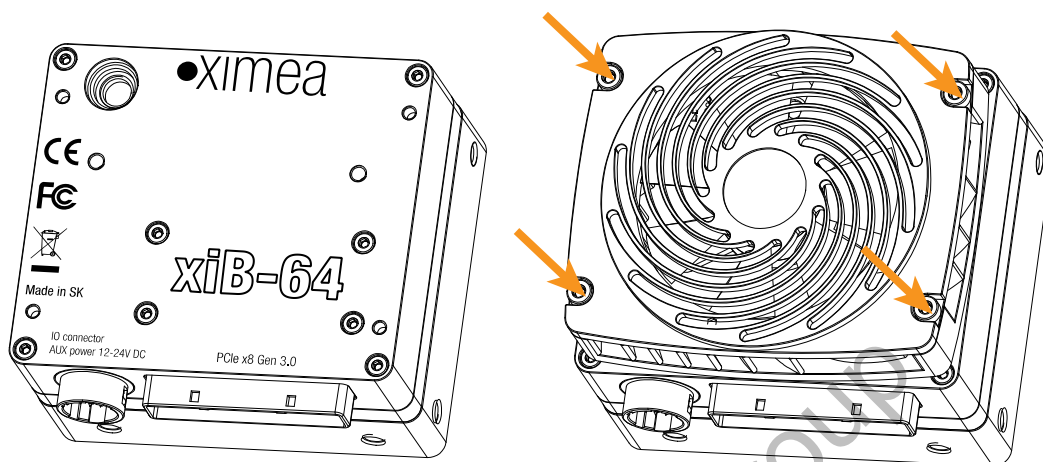

figure 3-60, mounting fan cooling element CB-X8G3-FAN-COOLER

The following image depicts the mounting holes on the back of the camera to mount different cooling elements.

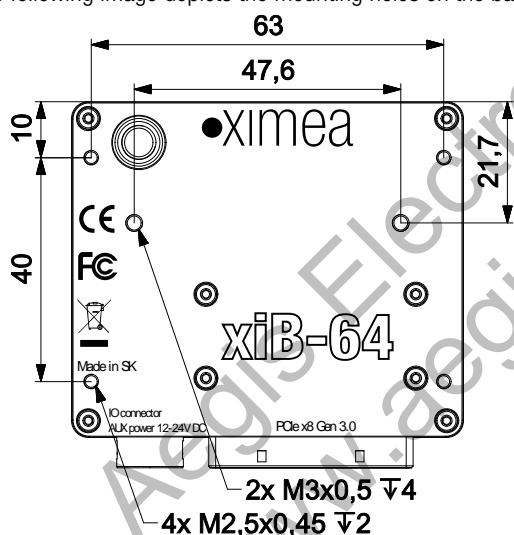

figure 3-61, rear mounting holes

3.17. xiB cooling – MECH-60MM-HEATSINK-KIT

xiB need to have proper cooling. Camera can be equipped with heatsink element MECH-60MM-HEATSINK as shown below. To mount MECH-60MM-HEATSINK it is necessary remove 4xM2 screws indicated in image below. These screws also hold the camera together, so this step must be done with care. Place the heatsink as depicted and return the four M2 screws you removed - unless the heatsink kit comes with different screws. It is advised to use thermal grease between the camera and heatsink to improve heat dissipation from the camera head.

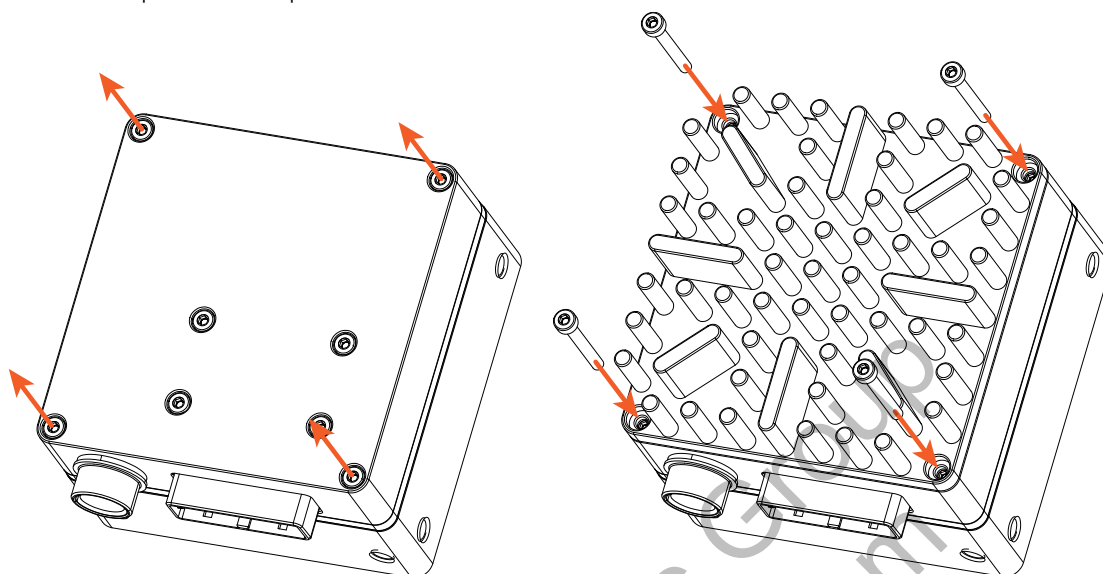

figure 3-62, mounting cooling element MECH-60MM-HEATSINK

Aegis Electronics
www.aegiselect.com

3.18. xiB Lens adapter – MECH-60MM-EF-ADAPTER

xiB and xiB-64 cameras features active control interface for lenses with CANON EF-mount. For attaching such lens MECH-60MM-EF-ADAPTER is required. Adapter is mounted using 4 front mount holes. Screws are included in MECH-60MM-EF-ADAPTER-KIT which can be purchased from XIMEA. Optionally camera can be assembled in production when the operation has been ordered along with camera (A-MECH-60MM-EF-ADAPTER-KIT).

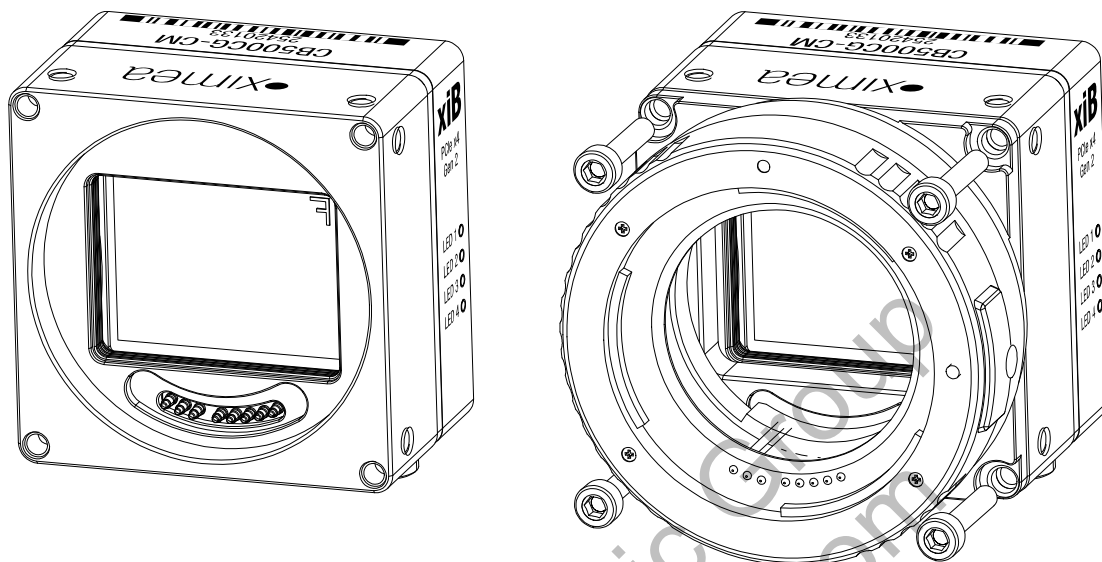

figure 3-63, mounting lens adapter with CANON EF-mount (MECH-60MM-EF-ADAPTER)

3.19. xiB Lens adapter – LA-C-MNT-60MM-xxx-KIT

xiB and xiB-64 cameras with 4/3" or smaller sensor can be equipped with C-mount lens adapter. With this adapter the C-mount lenses may be used. Adapter is mounted using 4 front mount holes. Optionally camera can be assembled in production when the operation has been ordered along with camera (A-LA-C-MNT-60MM-KIT). Mechanical dimensions of the LA-C-MNT-60MM-KIT assume usage of filter glass with thickness of 1mm and refraction index 1.4-1.55. Without filter glass the correct optical flange focal distance is not achieved.

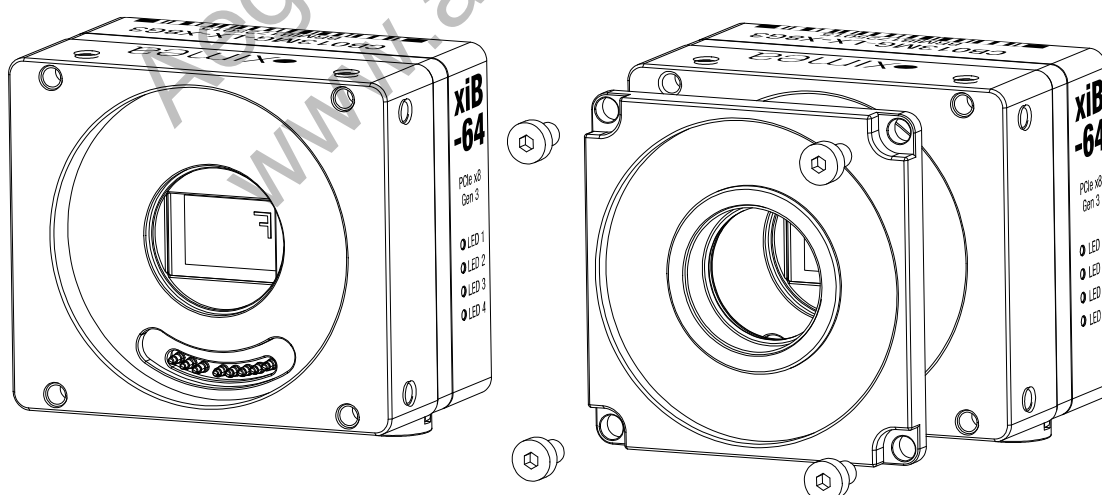

figure 3-64, mounting lens adapter with C-mount (LA-C-MNT-60MM-KIT)

4. Operation

For a proper operation of your xiB or xiB-64 camera there are certain requirements that have to be met. You will read more about these requirements in the following chapters, as well as a description of how to use a xiB camera. Please check our website for the most up to date information.

4.1. System Requirements

4.1.1. Software Requirements

The xiB & xiB-64 cameras are compatible with the following operating systems:

- Windows 10
- Windows 7 SP1
- Linux Ubuntu
- MacOS 10.8 or newer



All XIMEA cameras are compatible with the most advanced Vision and Image Processing Libraries.

See chapter [5 Software](#) for more information about the options to access a xiB cameras, as well as a list of currently supported libraries and frameworks supported in Windows.

For more information visit page: <https://www.ximea.com/support/wiki/apis/APIs>

4.1.2. Hardware Requirements

The XIMEA xiB & xiB-64 cameras are compatible with PCI express Generation 2 & 3.

Please note details and the most recent info at:

https://www.ximea.com/support/wiki/xib/PCI_Express_camera_-_xiB

4.1.2.1. System Configuration

Minimum system configuration:

For a basic operation of your xiB or xiB-64 camera with a PC the following minimum system configuration is required. Please note that bandwidth and processing performance are tied to the hardware configuration and the minimum hardware configuration could lead to a reduced bandwidth and limited frame rate.

CPU:	Intel i3 or better
RAM:	2GB RAM or more
Disc Space:	200 MB of free disc space
Video:	NVIDIA or Radeon graphics card 128MB or integrated on CPU
Ports:	Motherboard with PCIe x4-16 Gen 2(x8 Gen3 for xiB-64) slot for compatible PCIe host adapter See 3.12 PCIe host adapter cards

Recommended system configuration:

For best processing performance and bandwidth we recommend to use the following system configuration. This is essential when using the higher resolution models for achieving maximum frame rate.

CPU:	Intel i7
RAM:	8GB RAM or more
Disc Space:	400 MB of free disc space
Video:	NVIDIA or Radeon graphics card 128MB
Ports:	Motherboard with PCIe x4-16 Gen 2(x8 Gen3 for xiB-64) slot for compatible PCIe host adapter. See 3.12 PCIe host adapter cards

4.1.2.2. Cables

The PCI express cable that you use with the xiB or xiB-64 camera is responsible for the supply of power and the data transfer to the PC. It is critical to use an industrial PCI express cable with the proper wiring and shielding. We recommend using the cables listed in section [3.11 CBL-PCI-COP-xx/ CBL-PCI-FIB-](#).

4.2. Correct system connection and power on sequence

For a proper operation of your xiB camera specific order of steps need to be followed. All cables need to be connected with disconnected power from system. After enabling power to camera or recycling the power the host system need to be power on, or restarted.

Aegis Electronic Group
www.aegiselect.com

4.3. Video Formats

4.3.1. Full Resolution

By default, each camera outputs a full resolution image based on its sensor specification.

4.3.2. ROIs – Region Of Interest

ROI, also called area-of-interest (AOI) or windowing, allows the user to specify a sub-area of the original sensor size for read-out. Depending on the sensor inside xiB & xiB-64 cameras support the definition of one single ROI by specifying the size (width and height) as well as the position (based on upper left corner) of the of the sub-area.

Please note [3.6 Model Specific Characteristics](#)

4.3.3. Downsampling Modes

Downsampling describes the possibility of reducing the image resolution without affecting the sensors physical size, ie. without reducing the physical size of the sensing area. This feature is useful when optics are used, that are particularly fitted to a certain sensor size and if it is necessary to maintain the full image circle on the sensor.

Downsampling can be achieved in two ways: binning and skipping.

4.3.3.1. Binning

When binning is applied, the image is divided into cluster of $k \times l$ pixels, where all pixels in each cluster are interpolated and result in the value of one output pixel. For example, a 2×2 binning produces 2×2 pixel clusters and results in images with $\frac{1}{4}$ of the original resolution.

4.3.3.2. Skipping

When skipping is chosen, only every n -th pixel is used to create the output image. For example, with a 2×1 vertical skipping, every odd number line used and every even number line is skipped, resulting in an image with half its original vertical resolution. Skipping is a faster downsampling mode, but also introduces more aliasing effects.

Aegis Electronic Group
www.aegiselect.com

4.3.4. Image Data Output Formats

All modes are provided by the xiAPI or standard interfaces using the xiAPI (please note [5.1 Accessing the Camera](#)).

Each xiB or xiB-64 camera supports several Image Data Output Formats.

Mode	Description
RAW8	Raw sensor data, 8 Bit per pixel, single channel
RAW16	Raw sensor data, 16 Bit per pixel, single channel 10 or 12 Bit sensor output (LSB) with bit-shift up to 16 Bit
MONO8	Intensity output, 8 Bit per pixel, single channel
MONO16	Intensity output, 16 Bit per pixel, single channel
RGB24	RGB filtered output, 24 Bit per pixel, 3 channels Sequence: [Blue][Green][Red]
RGB32	RGBA filtered output, 32 Bit per pixel, 4 channels, Alpha channel equals 0. Sequence: [Blue][Green][Red][0]
RGB_PLANAR	RGB filtered output with planar-oriented channels. Format: [R][R]...[G][G]...[B][B]...
FRM_TRANSPORT_DATA	Data from transport layer (e.g. packed). This format is optimal when an efficient storage and later (offline) processing is required. Format is defined by XI_PRM_TRANSPORT_PIXEL_FORMAT

table 4-1, image formats,

Note1: For color modes **RGB32** and **RGB24** the image from sensor needs to be pre-processed (de-bayering). CPU load is higher in these modes. Setting this parameter will reset current region of interest. **RGB24** is being processed from the **RGB32** by removing the unused Alpha channel creating a slightly higher CPU load than the **RGB32** format.

Note2: The color filtering (de-bayering) relies on the interpolation of adjacent pixels in order to create pixel in the target image. Pixels on the edges of the image are missing adjacent pixels and therefore cannot be used for the interpolation process. The result is a target image that is smaller than the source image (4 pixels on all sides).

Note3: For most formats the transport data can be packed. 12-bit pixel bit depth transfers only 12bit per pixel compared to 16bit per pixel when the data are not packed. In case of packed format the CPU load is higher due to unpacking of the image data. Available bandwidth is however used optimally.

4.4. Acquisition modes

4.4.1. Free-Run

Also known as continuous acquisition. In this mode the sensor delivers a constant stream of image data at the maximum speed available by the current bandwidth, without any external trigger. Each image exposure is sequentially started automatically when possible.

For all sensors the exposure of the next frame overlaps with the data readout of the previous frame.

This Overlapped mode gives the highest number of frames per second (FPS).

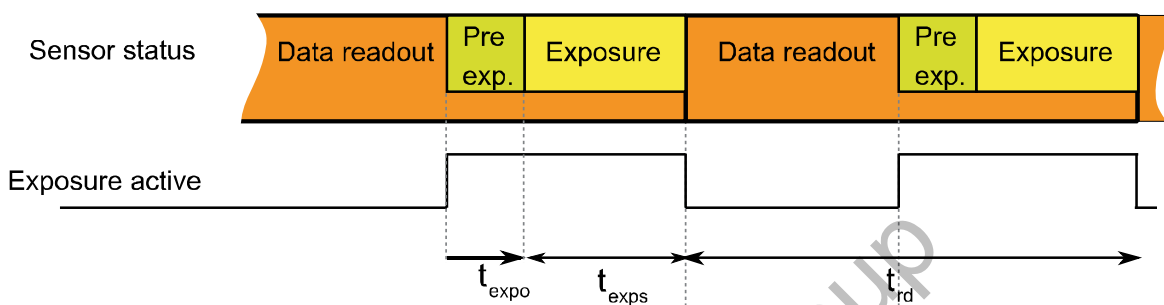

figure 4-1, acquisition mode - free run

In this mode the timing depends on the Exposure Time and Data Readout Time.

In situation when the exposure time is comparable or longer than readout time, the exposure active signal might have constant active level during acquisition. This might be caused also by different propagation delay for rising and falling edge of opto isolated outputs. (See [3.9.5 Optically isolated Digital Output](#)) Polarity inversion might help to make visible the separated exposure pulses.

All xiB & xiB-64 cameras support limiting of FPS. When set the camera will limit the frame rate so it does not exceed the set value. Please see: [Frame_Rate_Control: https://www.ximea.com/support/wiki/allprod/Frame_Rate_Control](https://www.ximea.com/support/wiki/allprod/Frame_Rate_Control)

This is also applicable in case of triggered acquisition.

4.4.2. Trigger controlled Acquisition/Exposure

Unlike in the free-run, each image exposure can also be triggered with an input trigger signal. In this mode, the sensor waits in stage until the trigger signal arrives. Only then, the exposure of first frame is started, which is followed by the data readout.

XIMEA cameras supports several triggered modes along with single image exposure after one trigger. The trigger signal can be either edge sensitive or level sensitive. In the case of 'level sensitive', it can be used to control length of exposure or acquisition itself.

Generally trigger sources can be divided into two groups:

Software Trigger

The trigger signal can be sent to the sensor using a software command. In this case, common system related latencies and jitter apply.

Hardware Trigger

A hardware trigger can be sent to the sensor using the digital input described in [3.9.4 Optically isolated Digital Input](#), or non-isolated ports configured as input described in [3.9.6 Non-isolated Digital Lines](#). Triggering by hardware is usually used to reduce latencies and jitter in applications that require the most accurate timing.

4.4.2.1. Triggered acquisition - single frame

Sensors support exposure overlapped with readout. When the trigger period (t_{tper}) is longer than the exposure plus readout time, exposure is not overlapped with readout. However when the trigger period is decreased, the sensor will expose the images in overlap mode. In this case, the frame active signal will be constantly active. The trigger period has to be long enough so the exposure of next frame does not end sooner than readout of previous frame.

Sensor timing in Exposure Overlapped with Data Readout Mode

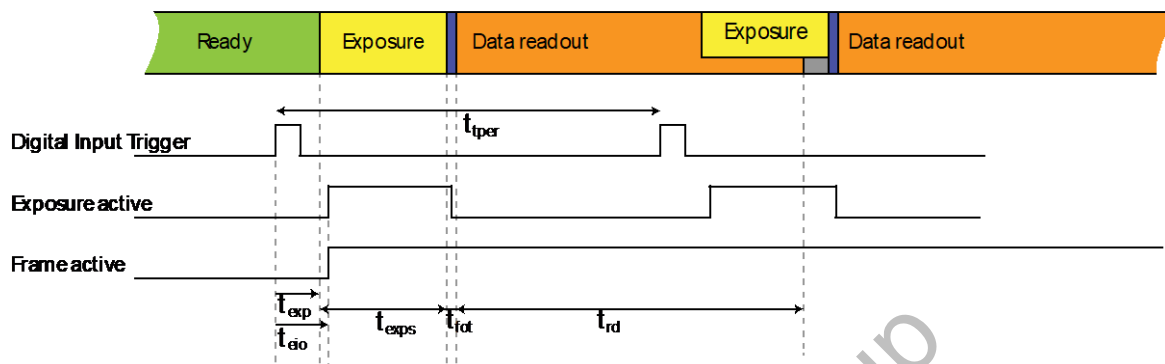

figure 4-2, acquisition mode – triggered with overlap

Description:

- t_{eio} – Trigger (Digital Input) to Exposure Active (Digital Output)
- t_{exp} – Trigger (Digital Input) to start of exposure
- t_{exps} – Current Exposure Time set (XI_PRM_EXPOSURE)
- t_{fot} – Frame overhead time (FOT)
- t_{rd} – readout time (Readout Time)
- t_{row} – readout time of one row (Line period) depends on sensor settings

Conditions: Debounce on trigger input line and trigger delay are disabled.

The timing strongly depends on camera settings. Most of the times can be calculated using [Camera performance calculator](#).

The delay between trigger input and start of exposure:

$$t_{exp} = t_{sensdelay} + t_{idelay}$$

Where:

- $t_{sensdelay}$ – Delay introduced by sensor itself. For most sensors the delay is constant. Cameras with CMV50000 sensor have this time dependent on setting of the sensor. Namely it is line period and bandwidth limit.
- t_{idelay} – Delay inside camera caused by internal electronics. This depends on input type. Please refer to: [3.9.4 Optically isolated Digital Input](#) or [3.9.6 Non-isolated Digital Lines](#)

The output signaling is then delayed the delay introduced from the output electronic.

$$t_{eio} = t_{exp} + t_{odelay}$$

Where:

- t_{odelay} – Delay inside camera caused by internal electronics. This depends on output type. Please refer to: [3.9.5 Optically isolated Digital Output](#) or [3.9.6 Non-isolated Digital Lines](#)

For minimum trigger period (t_{tper}) the following applies. The next trigger after one is processed needs to be applied so the end of the triggered exposure does not overlap with the readout of the previous frame.

$$t_{tper} > \max(t_{rd}, t_{exp}) + t_{fot}$$

4.4.2.2. Triggered acquisition - burst of frames

Frame Burst Start

In this mode each trigger pulse triggers defined number of exposed frames.

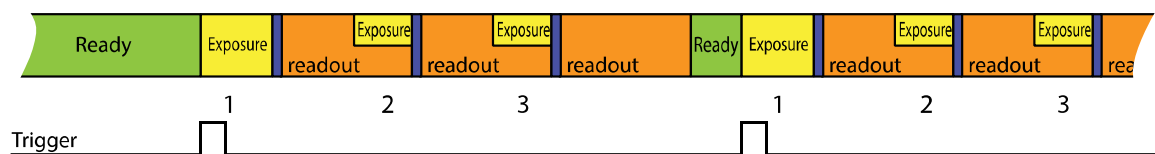

figure 4-3, triggered burst of frames – frame burst start, number of frames in burst set to 3

Frame Burst Active

If trigger is level sensitive it can be used to control image acquisition.

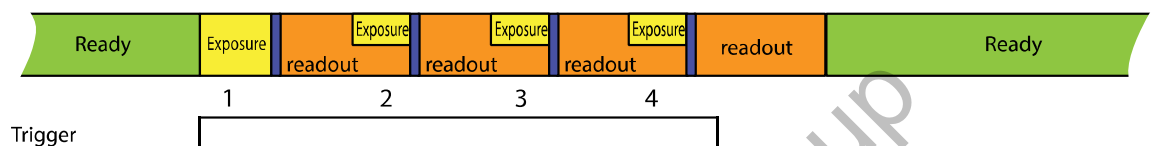

figure 4-4, triggered burst of frames – frame burst active

Please see: [Frame Burst Modes: https://www.ximea.com/support/wiki/allprod/Frame_Burst_Modes](https://www.ximea.com/support/wiki/allprod/Frame_Burst_Modes)

4.4.2.3. Exposure defined by trigger pulse length

In this mode the exposure is defined by trigger pulse length. This can be used to achieve longer exposure than allowed by API. Also it can be used to trigger several images in sequence with different exposure time. Exposure time is measured and reported in image metadata.

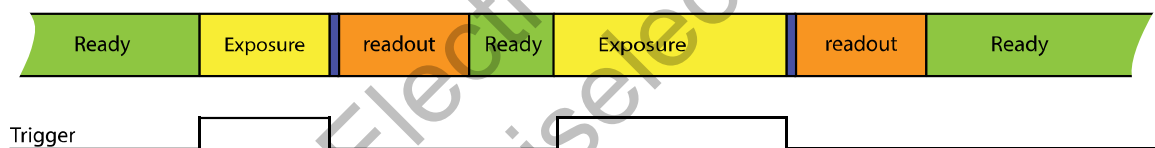

figure 4-5, Exposure defined by trigger pulse length

Please see: [Exposure Defined by Trigger Pulse Length: https://www.ximea.com/support/wiki/allprod/Exposure_Defined_by_Trigger_Pulse_Length](https://www.ximea.com/support/wiki/allprod/Exposure_Defined_by_Trigger_Pulse_Length)

https://www.ximea.com/support/wiki/allprod/Exposure_Defined_by_Trigger_Pulse_Length

4.5. Camera Parameters and Features

4.5.1. Exposure Time

Also known as shutter speed. This parameter defines the length of the integration period for each frame.

Most CMOS sensors generate the exposure interval internally. For some it is possible to control it by external signaling. The sensor internal timing depends on the provided system clock. Most sensors use dividers to generate slower clocks for internal usage.

The minimum exposure time is defined mostly by row times, where the row time (T_R) is dependent on various internal settings. Very few sensors support exposure times equal to zero. There is a defined minimum exposure time as well as minimum steps between possible exposure times. There is also a maximum exposure time, defined by sensor architecture.

4.5.2. Gain

The gain value influences the analog-to-digital conversion process of the image sensor pipeline and acts as a multiplier of the output signal. Using gain values greater than 0 will increase the pixel intensities but may also increase the overall noise level. For some camera models the gain can be set in discrete steps only.

4.6. Host-Assisted Image Processing Parameters Available in xiAPI.

4.6.1. Auto Exposure – Auto Gain

When AEAG is used, every captured image is evaluated for its mean intensity. Based on the result, the exposure and gain values are modified with the objective to achieve a target intensity level for the following image. Further, the maximum applicable exposure and gain values can be defined. Since both, exposure and gain, have an influence on the intensity, the ratio between those two parameters in their contribution to the algorithm can also be set (exposure priority).

4.6.2. White Balance

Only for color models: The white balance can be adjusted with three coefficients kR, kG and kB, one for each color channel. These coefficients can be set individually in order to increase or decrease each channel's contribution and therefore allow the user to control the color tint of the image.

4.6.2.1. Assisted Manual White Balance

This feature measures the white balance a single time and sets the white balance coefficient to achieve a mean grey (neutral) tint. The measurement is performed on the central rectangle of the image, with 1/8th of its width and height. The function expects a white sheet of paper exposed to 50% of the intensity values (8 Bit RGB values should be around 128) to be visible.

4.6.2.2. Auto White Balance

The white balance is measured across the full image for every 4th image that is acquired and the white balance coefficients are set to to achieve a neutral colour tint.

4.6.3. Gamma

Only for color models: As a part of the color filtering process, it is possible to adjust the gamma level of the image. The adjustment can be set separately for the luminosity and the chromaticity.

4.6.4. Sharpness

Only for color models: As a part of the color filtering process, it is possible to adjust the sharpness of the image.

4.6.5. Color Correction Matrix

The color correction matrix is a 4x4-matrix which is applied on each pixel of an image in a host-assisted port-processing step. For example, this Matrix can be used to adjust the brightness, contrast, and saturation.

4.6.6. Sensor Defect Correction

During the manufacturing process, every camera is tested for various type of defects and a list of the measured defect pixels is created and stored in the camera's non-volatile memory. This list is then used for the correction of acquired images during operation. The correction is inactive by default, but can be turned on by the user if a non-processed output is required.

Aegis Electronic Group
www.aegiselect.com

4.6.7. HDR

Some sensors offer the ability to acquire images with a higher dynamic range than the value presented in the specification. High dynamic range can be achieved by several means as part of the sensor output. The feature supported by CB200xG-CM camera is a piecewise linear response, a so-called multiple slope integration.

The dynamic range of a linear image sensor is limited by the saturation of the pixel. Different light intensities are shown in the figure below. All blue marked light intensities cause different signal levels and can be separated without saturation. All red marked intensities cause an overexposure and the info about the different light intensity above 100% is lost.

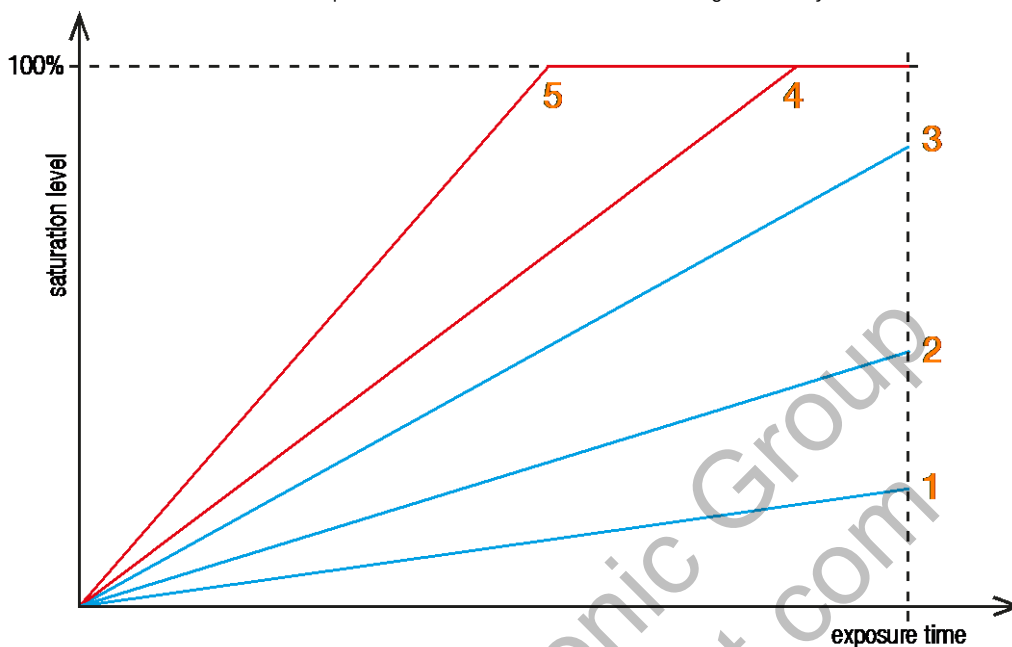

figure 4-6, image saturation example without HDR

Please note the exemplary corresponding positions 1 – 5 in the image with standard dynamic range:



figure 4-7, image example without HDR

The dynamic range can be increased by dividing the integration (exposure time) in two or three phases (slopes), with different maximum saturation levels. The CB200xG-CM camera supports the dividing in three slopes.

To use this kind of HDR method the user has to define two pairs of parameters: (T1, SL1) and (T2, SL2).

- T1 and T2 define portions of the total exposure time and the length of the three timing phases.
- SL1 and SL2 define portions of the sensor saturation, so called kneepoint1 and kneepoint2.

Please note the figure below:

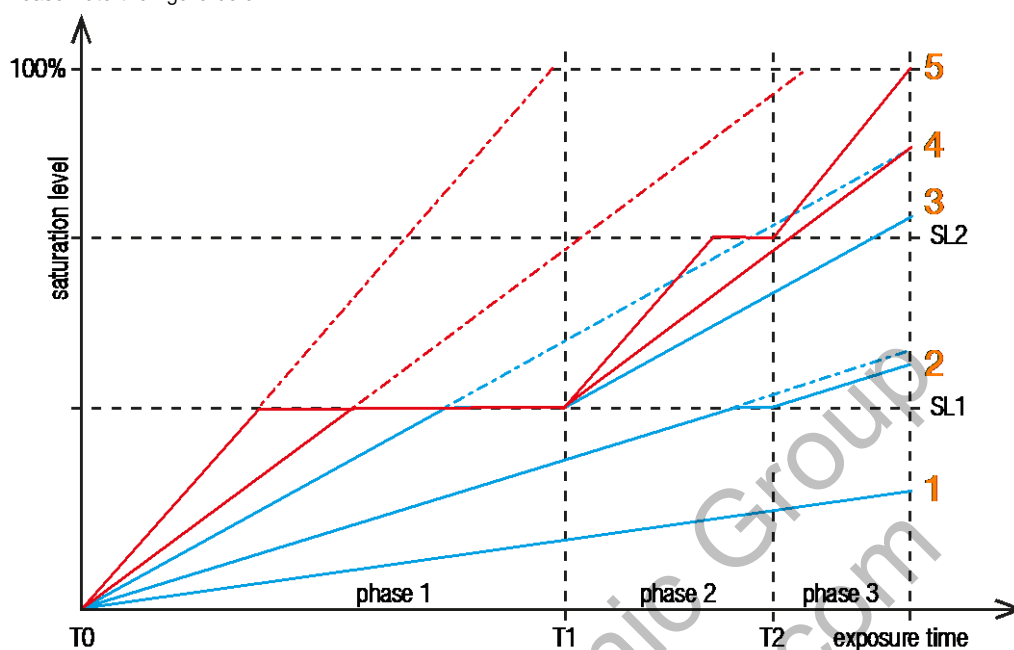

figure 4-8, image saturation example with HDR

Please note the exemplary corresponding positions 1 – 5 in the image with high dynamic range:



figure 4-9, image example with HDR

Description of the multiple slope integration:

Phase 1

- All pixels are integrated until they reach the defined saturation level of kneepoint1 (SL1).
- If the saturation level of kneepoint1 is reached, the integration stops. SL1 is the maximum saturation level for all pixels in this phase.

Phase 2

- All pixels are integrated until they reach the defined saturation level of kneepoint2 (SL2).
- If the saturation level of kneepoint2 is reached, the integration stops. SL2 is the maximum saturation level for all pixels in this phase.

Phase 3

- All pixels are integrated until the exposure time is reached. The pixel saturation may reach the maximum saturation level.

The main idea of this method is to reach an approx. logarithmic saturation curve. In order to achieve this goal phase2 always has a smaller slope than phase1 and phase3 smaller than phase 2. Thus, the signal response during phase1 is higher as during phase2. And the signal increase during phase2 is higher than during phase3.

As a result, darker pixels can be integrated during the complete integration time and the full sensor sensitivity can be exploited. Brighter pixels are limited at the knee points and lose a part of their integration time.

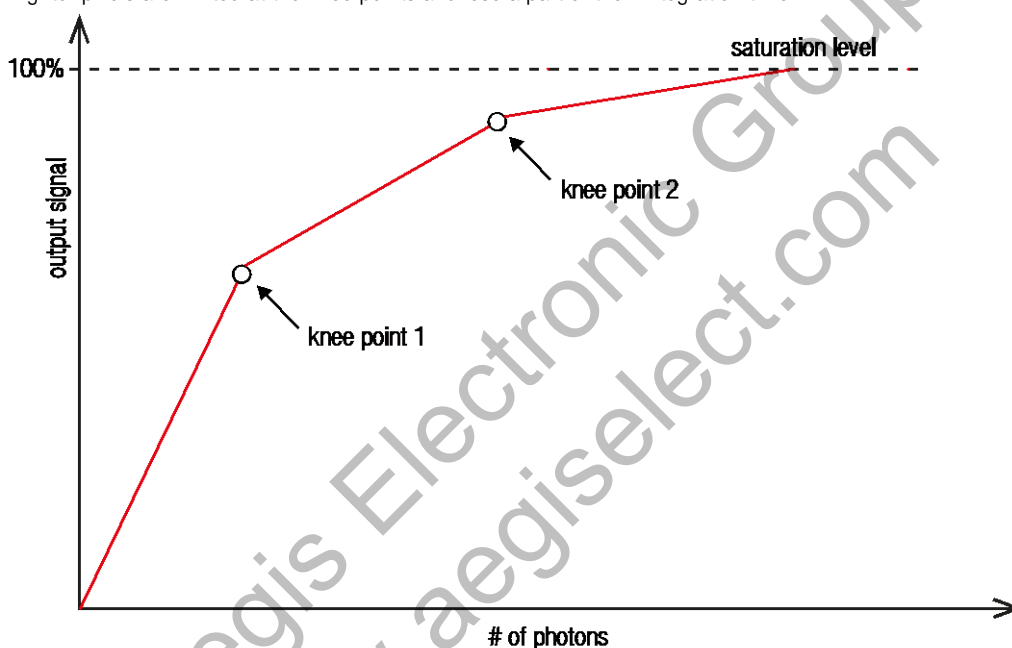

figure 4-10, HDR - approx. logarithmic saturation curve

5. Software

5.1. Accessing the Camera

Depending on the target application, the user can choose between several ways of accessing and controlling the camera. These can be divided into two categories: a programmatic approach, through programming code, or an integrated approach, through a supported, GUI based software package. The programmatic approach is generally used for the development of a custom application or image processing pipeline. The integrated approach is favored, if the specific toolset of a certain software package is sufficient and the camera serves as an integrated capture device.

5.1.1. Proprietary API

All XIMEA cameras are supported by the same unified APIs (application programming interface). The API is a software interface between the camera system driver and the application. Different APIs are available for different programming environments, e.g. *xiAPI* (see [5.7.1 XIMEA APIs](#)) for C/C++ developments and *xiAPI.Net* for C#.Net based developments

5.1.2. Standard Interface

As an alternative to the proprietary API, the camera can be accessed through a set of standard interfaces. These interfaces decouple a specific hardware design (e.g. physical interface) of a camera from its control in software. Therefore multiple camera classes and types can be used in a unified way.

5.1.2.1. GenICam

GenICam/GenTL provides a camera-agnostic transport layer interface to acquire images or other data and to communicate with a device. Each camera serves as a *GenTL Producer* which can be accessed in all software packages that are compatible with the GenICam standard, as well as through custom developments which implement this standard interface.

5.1.3. Vision Library Integration

All XIMEA cameras are compatible with the most advanced vision and image processing libraries. For GUI based software packages, the cameras can be directly accessed without the need of programming. Code libraries are generally used in conjunction with one of our APIs, in order to add additional functionality (e.g. image processing, communication, data storage).

5.2. XIMEA CamTool

The CamTool is a cross-platform application showcasing the features of all XIMEA camera families.



Short description

It runs on Windows, Linux, macOS systems offering a substantial imaging tool set, which can be further extended with custom modules using a plugin infrastructure. CamTool is based on Qt for the UI and xiAPI for the camera control. Its camera settings menu resembles the parameter set of the xiAPI

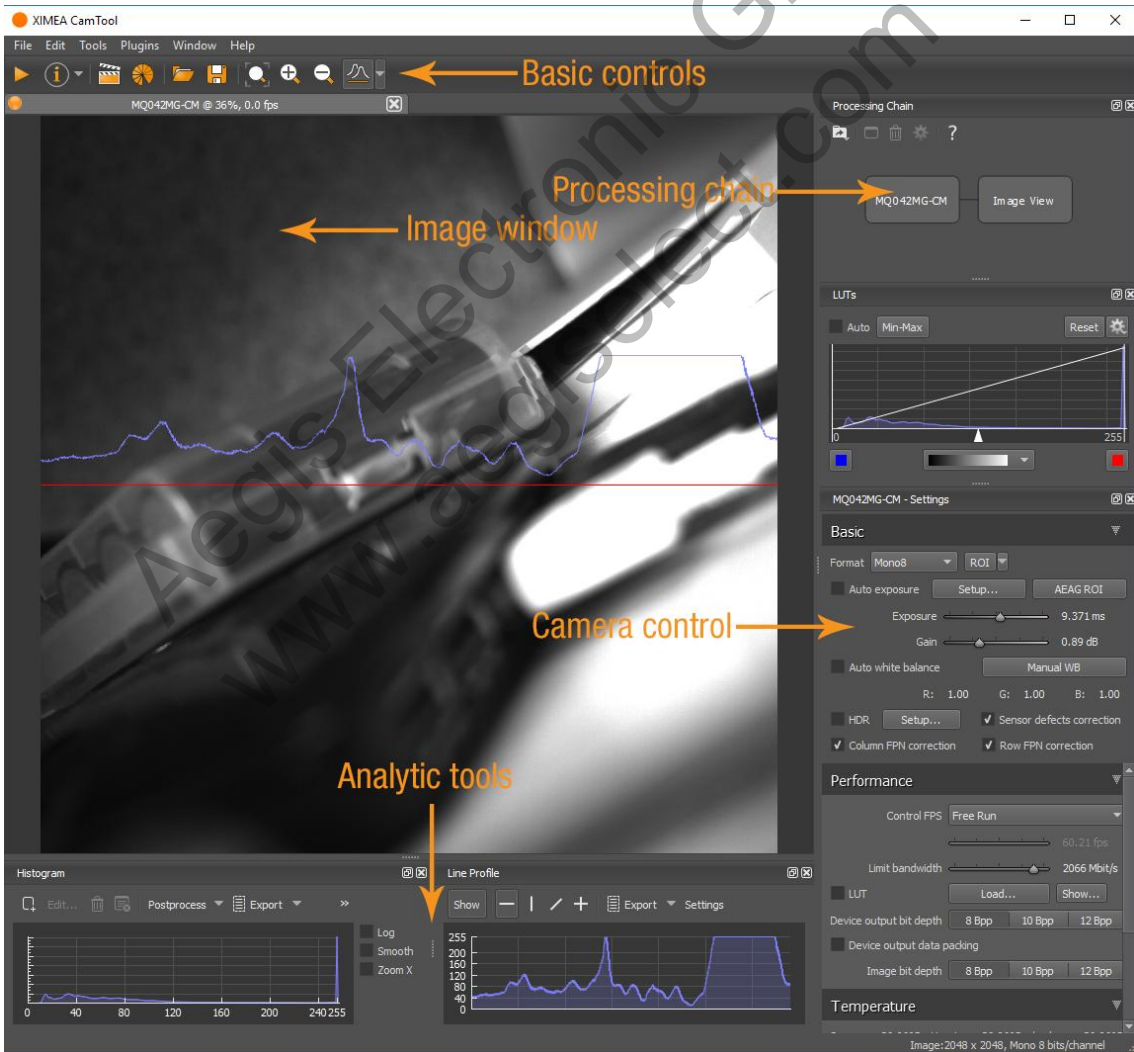

figure 5-1, CamTool Layout

Functions

- to see live image from multiple XIMEA cameras connected
- control the camera parameters
- store of camera image and video
- analyze the image properties
- histogram and line profile
- image averaging, image flip/mirror
- software trigger timer, save/load camera and program settings
- LUT (Look up table)
- Lua scripting

CamTool allows to operate all connected cameras simultaneously. In this case all control are layered for the cameras. Basic controls are placed as tabs in upper part of the window. Image window can be detached from application if needed. Amount of visible camera controls depend on visibility level which can be set in Edit→Options.

For more information please refer to: https://www.ximea.com/support/wiki/allprod/XIMEA_CamTool

Aegis Electronic Group
www.aegiselect.com

5.3. Supported Vision Libraries

For an up-to-date listing of the supported vision libraries and software packages, visit our web site <http://www.ximea.com/support/projects/vision-libraries/wiki>.

5.3.1. Libraries maintained by XIMEA

All cameras listed in the section Products are supported with these libraries.

XIMEA commits to update the API within twelve months after a new major release.

XIMEA warranties backwards compatibility of these software packages for two major releases.

5.3.1.1. MathWorks MATLAB



MathWorks® is the leading developer and supplier of software for technical computing and Model-Based Design.

More: <http://www.mathworks.de/> or https://www.ximea.com/support/wiki/vision-libraries/MathWorks_Matlab

5.3.1.2. MVTec HALCON



HALCON is the comprehensive standard software for machine vision with an integrated development environment (IDE) that is used worldwide.

More: <http://www.mvtec.com/halcon/> or https://www.ximea.com/support/wiki/vision-libraries/MVTec_HALCON

5.3.1.3. National Instruments LabVIEW Vision Library



LabVIEW is a graphical programming environment.

More: <http://www.ni.com/labview/>

https://www.ximea.com/support/wiki/vision-libraries/National_Instruments_LabVIEW

5.3.1.4. OpenCV



OpenCV is an open source library of programming functions mainly aimed at real time computer vision, developed by Intel and now supported by Willow Garage.

More: <https://opencv.org/>

<https://www.ximea.com/support/wiki/vision-libraries/OpenCV>

5.4. XIMEA Windows Software Package

XIMEA API Software Package can be installed on: Microsoft Windows 10, Microsoft Windows 8, Microsoft Windows 7 (and Microsoft Windows 7 Embedded), Microsoft Windows Server 2008 R2.

5.4.1. Contents

The package contains:

- OS Drivers of all XIMEA camera types for OS Microsoft Windows 7 SPI1 32/64 bit, Windows 8 32/64 bit, Windows Server 2008 R2 x86-64, Windows 10 32/64 bit.
- APIs (*xiAPI*, *xiAPI.NET*, *xiApiPython*)
- Examples
- CamTool
- xiCop
- *GenTL Producer* - for connection of *GenTL Consumer* applications.
- **Vision Libraries** integration demonstrations:
 - NI LabView interface - xiLib

5.4.2. Installation

- Download and execute the **XIMEA API Software Package** installer (EXE-file, approximate size 100 MB): http://www.ximea.com/downloads/recent/XIMEA_Installer.exe
- Read the License Agreement.
- Start the installer

Be sure that you have administrator privileges or start the installer with administrator rights (right click and select "run as administrator):

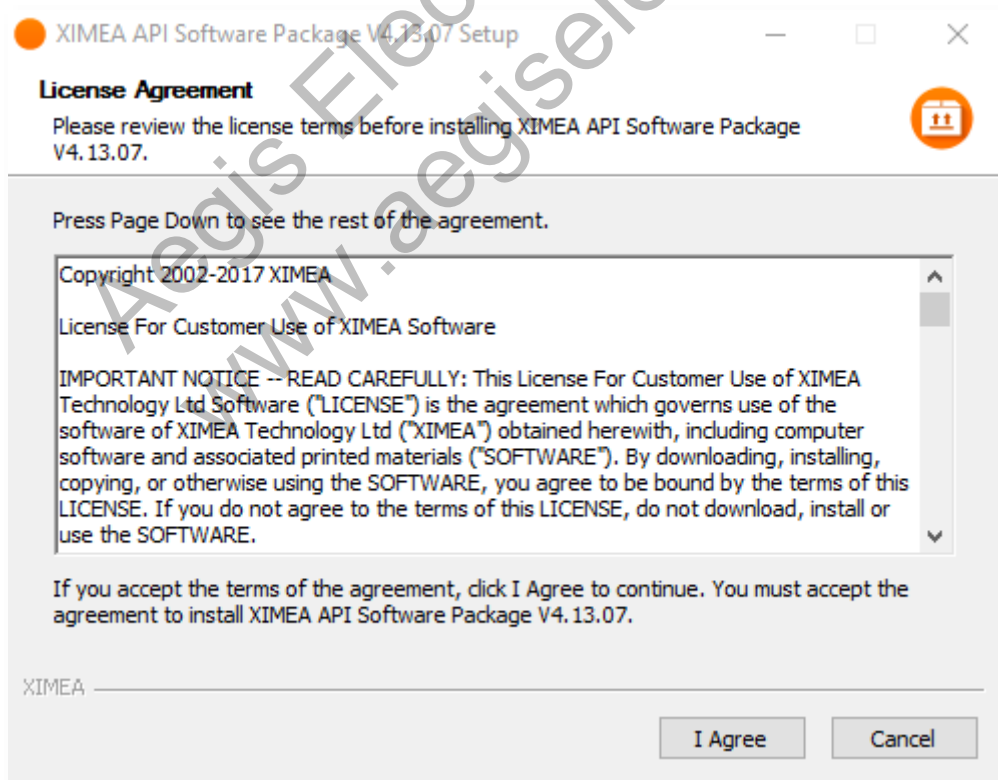

figure 5-2, XIMEA Windows Software Package installation - 1

- Select the Software components you want to install. You can uncheck the components you don't want to install, but it is recommended to leave them all checked.

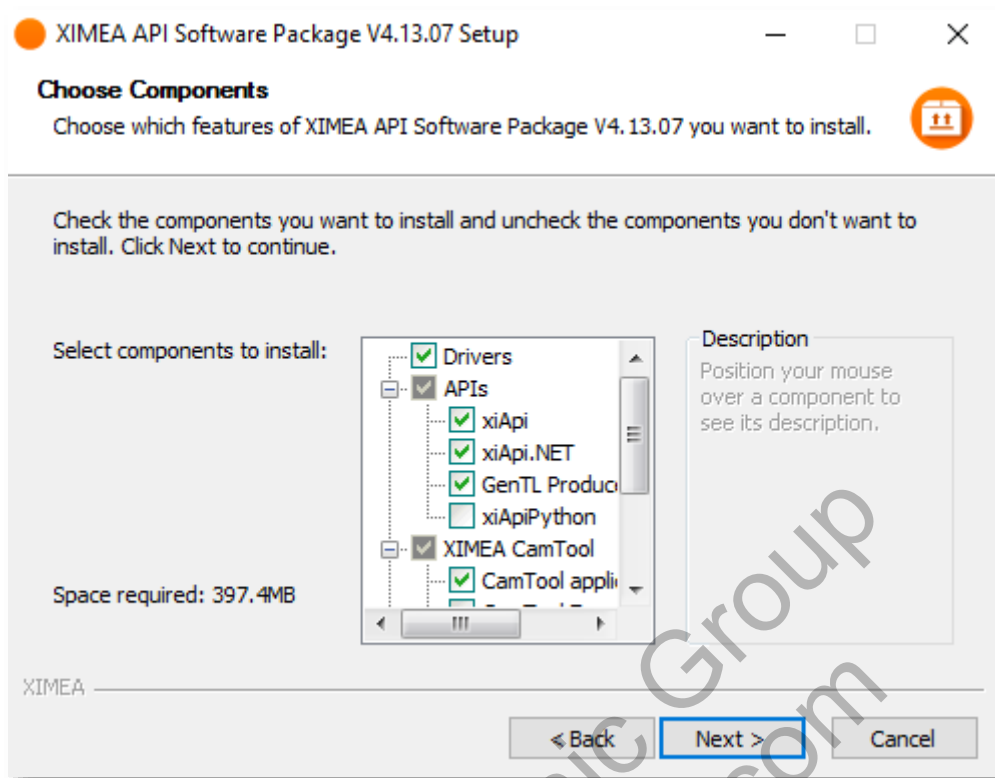

figure 5-3, XIMEA Windows Software Package installation - 2

- Specify the install location - you can leave the default location or change it to your desired location.

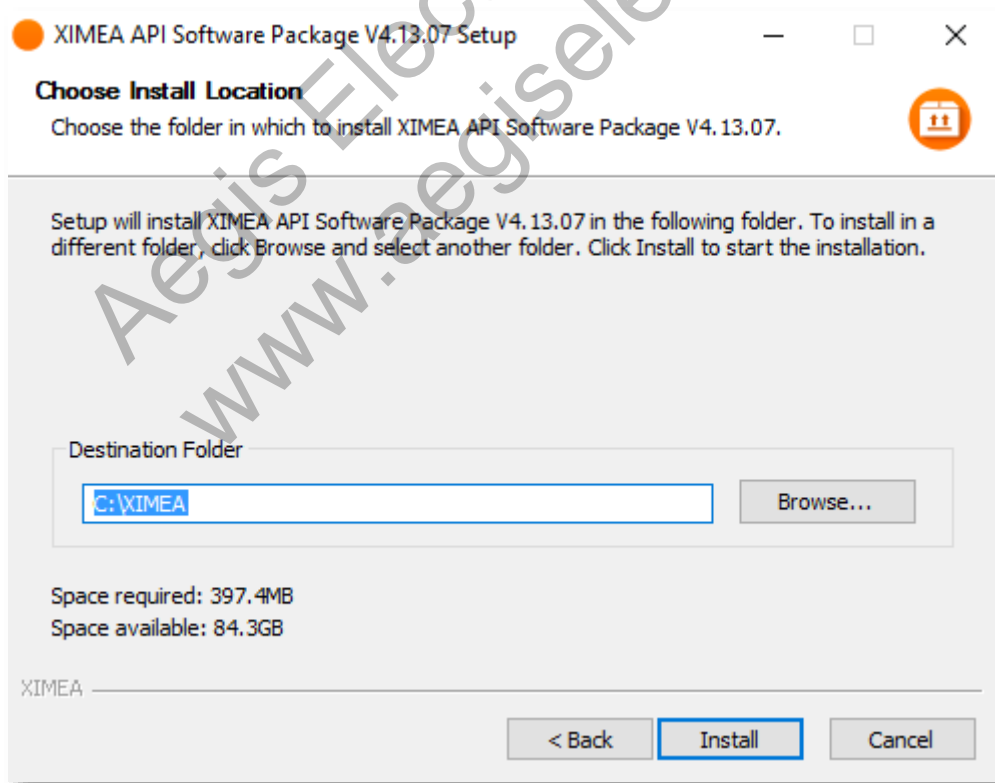

figure 5-4, XIMEA Windows Software Package installation - 3

- Now the XIMEA API Software Package should start copying files, updating System Variables and installing drivers if necessary.

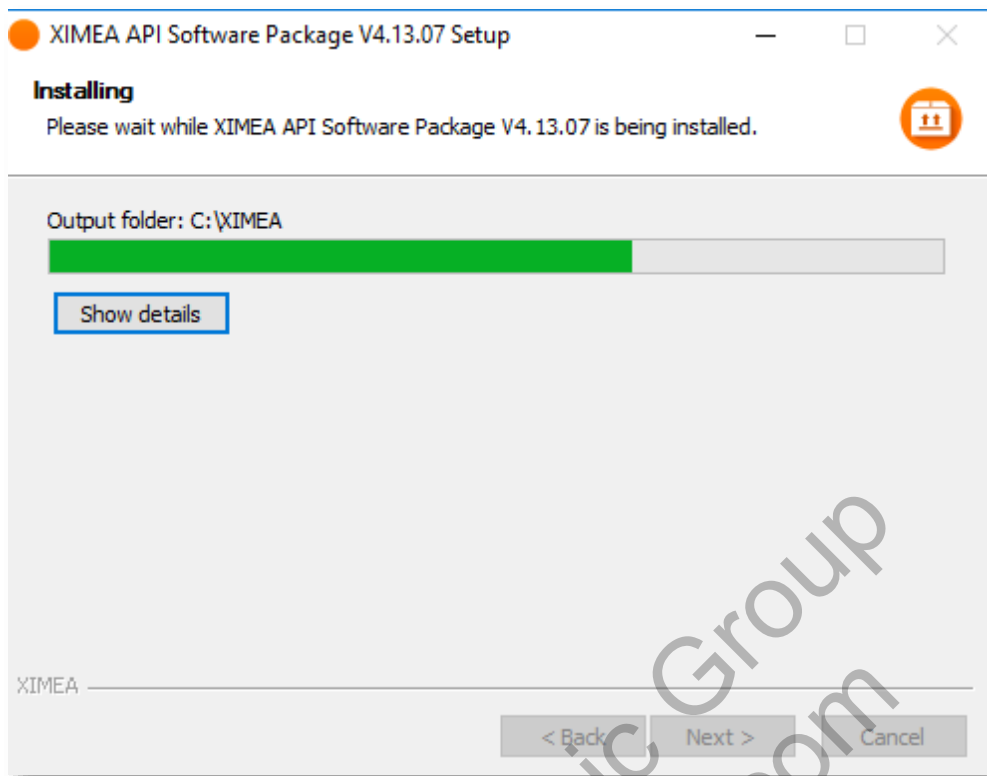

figure 5-5, xiAPI installation, Windows - 4

- Installation is completed.

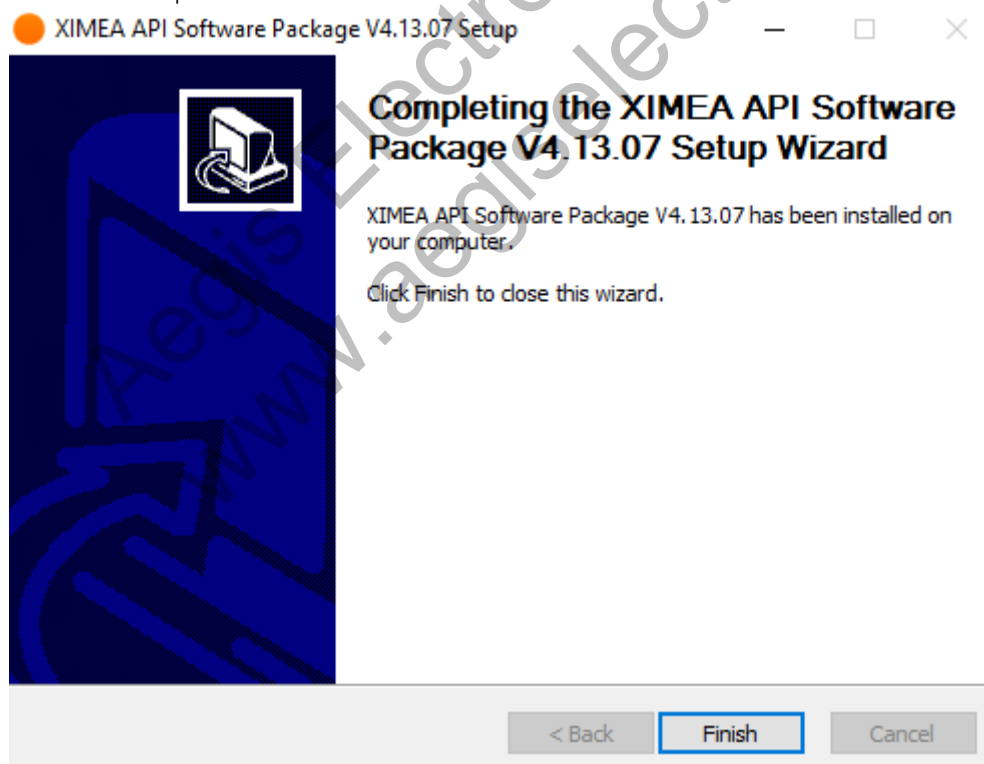

figure 5-6, xiAPI installation, Windows - 5

- Finish.

5.5. XIMEA Linux Software Package

XIMEA Linux Software Package is tarred installer with files that can be run on Linux Ubuntu 14.04 and 16.04 (32 and 64 Bit) and newer releases.

5.5.1. Contents

The package contains:

- Driver (beta version) for XIMEA USB2 and USB3 cameras
- xiAPI
- Ximea CamTool
- Examples:
 - xiSample - sample showing basic image acquisition in xiAPI

5.5.2. Installation

- Download **XIMEA Linux Software Package**

```
wget http://www.ximea.com/downloads/recent/XIMEA_Linux_SP.tgz
```



```
ximea@ximea-Linux64: ~
ximea@ximea-Linux64:~$ wget http://www.ximea.com/downloads/recent/XIMEA_Linux_SP.tgz
--2013-06-05 17:06:29-- http://www.ximea.com/downloads/recent/XIMEA_Linux_SP.tgz
Resolving www.ximea.com (www.ximea.com)... 91.143.80.251
Connecting to www.ximea.com (www.ximea.com)|91.143.80.251|:80... connected.
HTTP request sent, awaiting response... 301 Moved Permanently
Location: http://www.ximea.com/support/attachments/271/XIMEA_Linux_SP.tgz [following]
--2013-06-05 17:06:30-- http://www.ximea.com/support/attachments/271/XIMEA_Linux_SP.tgz
Connecting to www.ximea.com (www.ximea.com)|91.143.80.251|:80... connected.
HTTP request sent, awaiting response... 200 OK
Length: 3885021 (3.7M) [application/octet-stream]
Saving to: `XIMEA_Linux_SP.tgz'

100%[=====>] 3,885,021  2.09M/s  in 1.8s

2013-06-05 17:06:31 (2.09 MB/s) - `XIMEA_Linux_SP.tgz' saved [3885021/3885021]

ximea@ximea-Linux64:~$
```

figure 5-7, XIMEA Linux Software Package installation - 1

- Untar

```
tar xzf XIMEA_Linux_SP.tgz
cd package
```
- Start installation script

```
./install-pcie
```

```

ximea@ximea-Linux64: ~/package
ximea@ximea-Linux64:~$ tar xzf XIMEA_Linux_SP.tgz
ximea@ximea-Linux64:~$ cd package
ximea@ximea-Linux64:~/package$ ./install -cam_usb30
This will install XIMEA Linux Package after 5 seconds
To abort installation - press Ctrl-C
Installing x64 bit version
[sudo] password for ximea:
This is installation of package for platform -x64
Checking if user is super user
OK
-----
WARNING!!!
You have enabled experimental USB3 support! It may affect USB2 support too.
DO NOT downgrade the kernel to versions older than 3.4!!!
Advised way of enabling USB3 support is upgrading kernel to version at least as new as 3.6.
If you decide to do it in the future, rerun this installation script after rebooting into new kernel.
-----
Installing libusb
OK
Installing Firewire support - libraw1394
OK
Checking Firewire stack

Installing API library
OK
OK
OK

Rebuilding linker cache
Installing XIMEA-GenTL library
OK
Installing vaViewer
OK
Installing streamViewer
OK
Installing xiSample
OK
Creating desktop link for vaViewer
Creating desktop link for streamViewer
Installing udev rules for USB and Firewire cameras
OK
-----
Note:
You may need to reconnect your USB and/or Firewire cameras
Also check that you are in the "plugdev" group

More info:
http://www.ximea.com/support/wiki/apis/Linux_USB20_Support
-----
For GeniCam - please add GENICAM_GENTL64_PATH=/opt/XIMEA/lib/libXIMEA_GenTL.so to Your .bashrc to enable GenTL
Now applications can be started. E.g. /opt/XIMEA/bin/xiSample
-----
Done OK
ximea@ximea-Linux64:~/package$

```

figure 5-8, XIMEA Linux Software Package installation - 2

- 1) **Note:** If logged in user is not root, you will be asked for your password to get root access, because the installation runs with root account using *sudo*.

5.6. XIMEA macOS Software Package

XIMEA macOS Software Package is native DMG installer that can be run on macOS 10.8 (Mountain Lion) or newer.

5.6.1. Contents

The package contains:

- Driver (beta version) for all XIMEA cameras
- xiAPI
- XIMEA CamTool
- Examples:
 - xiSample - sample showing basic image acquisition in xiAPI

5.6.2. Installation

Before installing XIMEA macOS Software Package it may be necessary to modify security settings on your computer. The new feature of OS X 10.8 called GateKeeper can prevent you from using our macOS Software Package due to the fact that the current version is unsigned.

Open System Preferences application and click on Security & Privacy.



figure 5-9, XIMEA macOS Software Package installation - 1

On the General Tab select the option Anywhere under Allow applications downloaded from:



figure 5-10, xiAPI installation, MacOS - 2

- Download XIMEA macOS Software. Package: http://www.ximea.com/downloads/recent/XIMEA_OSX_SP.dmg
- Mount it by double-clicking this file in Finder.
- Run the install script to install XiAPI on your macOS system
- A window with package contents will open.

5.6.3. Start XIMEA CamTool

- Connect camera
- Start Applications / XIMEA CamTool
- Start acquisition by clicking on orange triangle at upper left corner of CamTool

5.7. Programming

5.7.1. XIMEA APIs

- **xiAPI** - Streamlined API. The standard API for C/C++ based projects, see [5.7.2 xiAPI Overview](#).
- **xiAPI.NET** - Managed .NET Common Language Runtime (CLR) API.
xiAPI.NET is designed as a wrapper around xiAPI and therefore shares most of its functionality.
- **xiApiPython** – Integrated API into PYTHON.

5.7.2. xiAPI Overview

xiAPI stands for XIMEA Application Programming Interface. It is a common interface for all XIMEA cameras.

Architecture

API is a software interface between the camera system driver and application.

- On Windows: xiAPI is compiled into xiapi32.dll or xiapi64.dll
- On Linux: xiAPI is compiled into /usr/lib/libm3api.so

Installation

xiAPI is part of all current XIMEA software packages for Windows, Linux and MacOS.

For information on the software packages, see 5 Software

5.7.3. xiAPI Functions Description

The core of xiAPI consists of the following functions, which allow controlling of the camera functionality.

```
// get the number of discovered devices.
XI_RETURN xiGetNumberDevices(OUT DWORD *pNumberDevices);

// open interface
XI_RETURN xiOpenDevice(IN DWORD DevId, OUT PHANDLE hDevice);

// get parameter
XI_RETURN xiGetParam(IN HANDLE hDevice, const char* prm, void* val,
DWORD * size, XI_PRM_TYPE * type);

// set parameter
XI_RETURN xiSetParam(IN HANDLE hDevice, const char* prm, void* val,
DWORD size, XI_PRM_TYPE type);

// start the data acquisition
XI_RETURN xiStartAcquisition(IN HANDLE hDevice);

// acquire image and return image information
XI_RETURN xiGetImage(IN HANDLE hDevice, IN DWORD TimeOut, INOUT XI_IMG
* img);

// stop the data acquisition
XI_RETURN xiStopAcquisition(IN HANDLE hDevice);

// close interface
XI_RETURN xiCloseDevice(IN HANDLE hDevice);
```

5.7.4. xiAPI Parameters Description

For a complete list of available parameter, please visit the xiAPI online manual at http://www.ximea.com/support/wiki/apis/XiAPI_Manual

Note: Since xiAPI is a unified programming interface for all of XIMEA's cameras, not all of the described parameters apply for every camera and sensor model.

All functions in xiAPI return status values in form of the *XI_RETURN* structure which is defined in *xiApi.h*. If a parameter is not supported by a certain camera, the return value will represent a respective error code (e.g. *106 - Parameter not supported*).

5.7.5. xiAPI Examples

5.7.5.1. Connect Device

This example shows the enumeration of available devices. If any device was found the first device (with index 0) is opened.

```
HANDLE xiH = NULL;

// Get number of camera devices
DWORD dwNumberOfDevices = 0;
xiGetNumberDevices (&dwNumberOfDevices);

if (!dwNumberOfDevices)
{
    printf("No camera found\n");
}
else
{
    // Retrieving a handle to the camera device
    xiOpenDevice(0, &xiH);
}
```

5.7.5.2. Parameterize Device

This example shows how an exposure time is set. Next, the maximum possible downsampling rate is retrieved and the result is set as new downsampling rate.

```
// Setting "exposure" parameter (10ms)
int time_us = 10000;
xiSetParam(xiH, XI_PRM_EXPOSURE, &time_us, sizeof(time_us),
xiTypeInteger);

// Getting maximum possible downsampling rate
int dspl_max = 1;
xiGetParamInt(xiH, XI_PRM_DOWNSAMPLING XI_PRM_INFO_MAX, &dspl_max);

// Setting maximum possible downsampling rate
xiSetParamInt(xiH, XI_PRM_DOWNSAMPLING, dspl_max);
```

5.7.5.3. Acquire Images

This example shows how the acquisition is started on the device with the handle xiH, ten images are acquired in a row and the acquisition is stopped.

```
xiStartAcquisition(xiH);

#define EXPECTED_IMAGES 10
for (int images=0;images < EXPECTED_IMAGES;images++)
{
    // getting image from camera
    xiGetImage(xiH, 5000, &image);
    printf("Image %d (%dx%d) received from camera\n", images,
        (int)image.width, (int)image.height);
}
xiStopAcquisition(xiH);
```

5.7.5.4. Control Digital Input / Output (GPIO)

Hardware Trigger and Exposure Active output

In this setup each image is triggered by a Digital Input Trigger. After the image is triggered, it can be transferred using xiGetImage.

This setup ensures a low latency between the trigger signal and image Exposure start. This time should be less than 10 μ s.

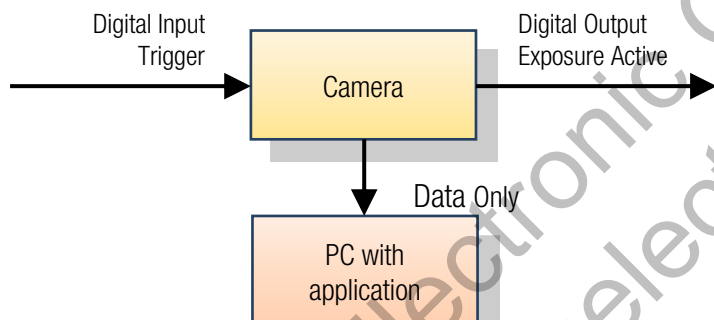

figure 5-11, GPIO - schematic

```
HANDLE xiH;
xiOpenDevice(0, & xiH);

// select trigger source
xiSetParamInt(xiH, XI_PRM_TRG_SOURCE, XI_TRG_EDGE_RISING);

// select input pin 1 mode
xiSetParamInt(xiH, XI_PRM_GPI_SELECTOR, 1);
xiSetParamInt(xiH, XI_PRM_GPI_MODE, XI_GPI_TRIGGER)

// set digital output 1 mode
xiSetParamInt(xiH, XI_PRM_GPO_SELECTOR, 1);
xiSetParamInt(xiH, XI_PRM_GPO_MODE, XI_GPO_EXPOSURE_ACTIVE);

xiStartAcquisition(handle1);

// Trigger signal should start image exposure within timeout
#define TIMEOUT_IMAGE_WAITING_MS 10000
xiGetImage(handle, TIMEOUT_IMAGE_WAITING_MS, &image);
// process image here...
```

5.7.6. xiAPI Auto Bandwidth Calculation

xiAPI uses Auto Bandwidth Calculation (ABC) before the opening of each camera by default. After the measurement, 90% of the measured value is used as the maximum allowed transfer speed of the camera to ensure the stability of transfer.

It is important to set this parameter to XI_OFF to ensure highest possible data transfer speed.

To disable ABC, the application should set parameter XI_PRM_AUTO_BANDWIDTH_CALCULATION to XI_OFF before the first xiOpenDevice is used. This setting disabled ABC and the camera stream is not limited.

5.7.7. GenICam

For more information on programming according the GenICam standard, please visit the standard's website at <http://www.emva.org/standards-technology/genicam/>

Aegis Electronic Group
www.aegiselect.com

5.8. XIMEA Control Panel

The XIMEA Control Panel (xiCOP), is a diagnostics and management tool for all XIMEA cameras. xiCOP is currently only available for Windows operating system.

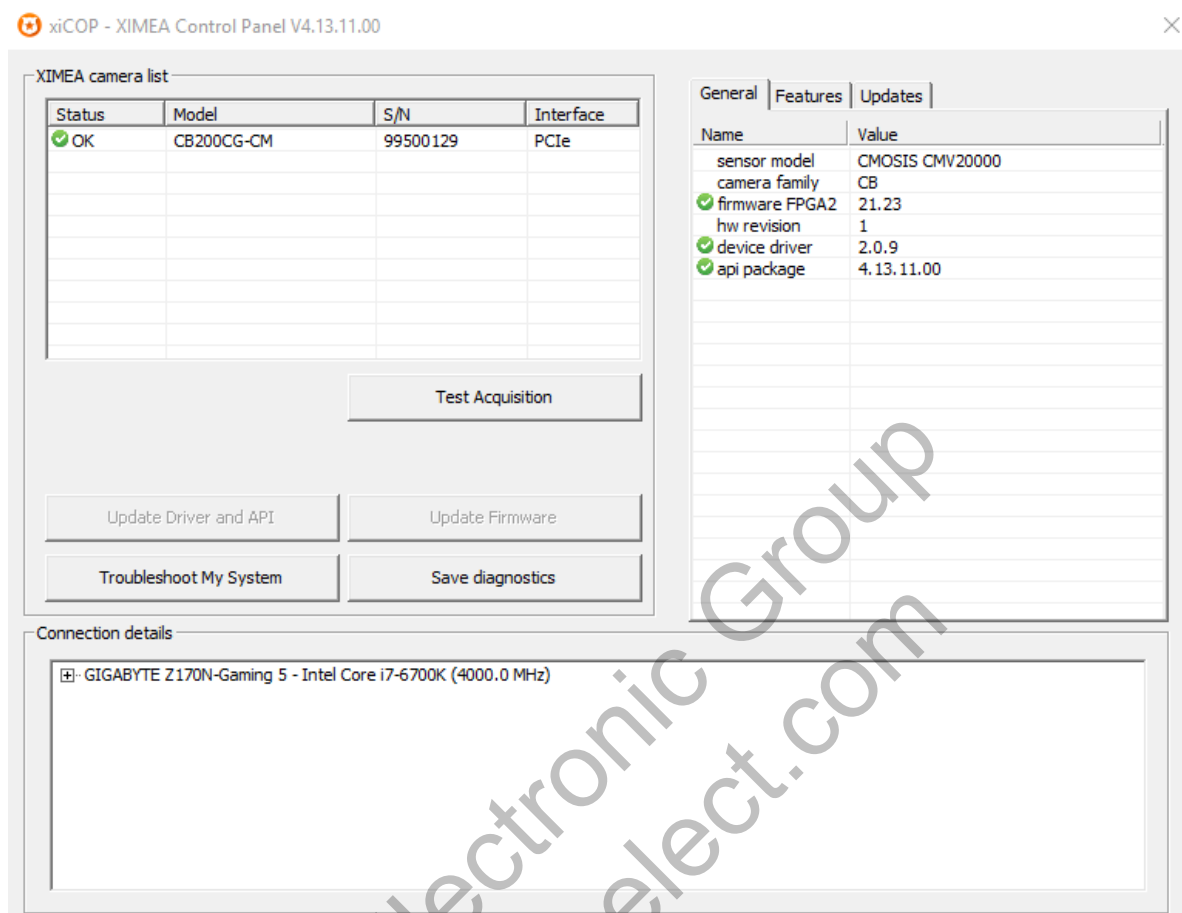

figure 5-12, xiCOP

Features

- Facilitates diagnostics of system performance bottlenecks. xiCOP is capable of retrieving the system's hardware tree, thus problematic hardware configurations can be identified.
- Diagnosis of firmware and software compatibility. xiCOP checks relevant firmware and software versions and warns if a component is not up-to-date.
- List all currently attached XIMEA devices and their features.
- Suggests solution for diagnosed issues.
- One click update to the latest XIMEA API Software Package.
- One click update of firmware in selected cameras.

6. Appendix

6.1. Troubleshooting and Support

This chapter explains how to proceed, if you have issues in getting your xiB or xiB-64 camera to a proper operation. At first, please make sure, that you have installed the latest version of the following XIMEA software:

- **XIMEA Windows Software Package** http://www.ximea.com/downloads/recent/XIMEA_Installer.exe

Please make sure, that you have connected your xiB or xiB-64 camera with the corresponding PCIe cable to appropriate port on your PCIe host adapter card. Ensure that the connections are carefully locked. Follow the instructions described in chapter [5.2 XIMEA CamTool](#) (run the xiB or xiB-64 camera with the XIMEA CamTool). If this does not at first work, please check all your connections to the camera (power and PCIe) and then try the latest 'beta' version of API with the most recent fixes:

https://www.ximea.com/downloads/recent_beta/XIMEA_Installer.exe

In case that you still have issues, please read the following chapters.

6.1.1. Worldwide Support

We offer worldwide first level support to you by our partners.

Please refer to your local dealer if you need technical support for your xiB or xiB-64 camera.

6.1.2. Before Contacting Technical Support

There are a few steps to take before contacting your local dealer for technical support. In case you cannot display images from your xiB or xiB-64 camera, please open the XIMEA xiCOP software (please see [5.8 XIMEA Control Panel](#)). It will immediately start searching for connected cameras. Your camera will appear in the XIMEA camera list on the upper left side of the xiCOP window if it is connected properly and your PCIe host interface meets the minimum system requirements described in [4.1 System Requirements](#). If the camera does not appear, please proceed with the following steps:

Step no:	Description
1	Click on the button "Troubleshoot My System" and follow the instructions that are suggested.
2	If step 1 does not lead to a positive result, please click the button "Save diagnostics". Keep the diagnostic file ready for providing it to support.
3	Contact your local dealer where you bought the camera either by phone or by email for first level support. He will decide if he can help you immediately or if more information is necessary for initiating the next steps.

table 6-1, use xiCOP before contacting technical support

6.1.3. Frequently Asked Questions

In this manual, we can list only a few FAQ. For more and updated information, please also note:

- **Frequently Asked Questions** http://www.ximea.com/support/wiki/allprod/Frequently_Asked_Questions
- **Knowledge Base** http://www.ximea.com/support/wiki/allprod/Knowledge_Base

6.1.3.1. What is the real transfer speed?

xiB-64 camera can deliver up to 8Gbyte/sec. This requires that certain conditions are met, see [4.1 System Requirements](#).

Maximum transfer speeds of different interfaces:

Interface	Transfer speed	Usable bandwidth	System costs
IEEE1394A	400 Mbit/s	45 MByte/sec	Medium
CameraLink base	2.04 Gbit/s	255 MByte/sec	High
GigE	1024 Mbit/s	100 MByte/sec	Medium
USB 2.0	480 Mbit/s	49 MByte/sec	Low
USB 3.0	5 Gbit/s	450 MByte/sec	Low
USB 3.1 (gen1)	5 Gbit/s	450 MByte/sec	Low
PCIe gen2 x2	8 Gbit/s		Low
PCIe gen2 x4	16Gbit/s		Low
PCIe gen3 x8	64Gbit/s		Low

table 6-2, interface depending transfer rates

6.1.3.2. Why can I not achieve maximum transfer speed?

In order to reliably achieve maximum transfer speed it is necessary to verify that you are using recommended hardware (please see [4.1 System Requirements](#)), and that all software requirements are met.

xiCOP (please see [5.8 XIMEA Control Panel](#)) - XIMEA Control Panel free software tool, facilitates the task of verification of XIMEA camera installations.

6.2. Product service request (PSR)

If you experienced any unexpected behavior of your xiB or xiB-64 camera, please follow the steps described below:

6.2.1. Step 1 - Contact Support

If your xiB or xiB-64 camera is not working as expected, please contact your local dealer for troubleshooting the product and determine the eligibility of a Product Service Request (PSR).

In case you were asked to create a PSR by your local contact, please continue to STEP 2

NOTE: Your product must be UNDER WARRANTY in order to qualify for a free repair or replacement.

6.2.2. Step 2 - Create Product Service Request (PSR)

- Read the [XIMEA General Terms & Conditions](http://www.ximea.com/en/corporate/generaltc)
- Open the [XIMEA Product Service Request form](http://www.ximea.com/support/projects/service/issues/new)
- Fill in all fields
- Confirm with the button „Create“

6.2.3. Step 3 - Wait for PSR Approval

Our support personnel will verify the PSR for validity.

If your PSR is valid, it will be approved for sending the camera to us. This is done usually within 24 business hours. After that you will get a PSR Approval email (sent to the email address that you have entered in the field “Contact person – email”).

The email contains:

- shipping instructions
- attached document containing the Product Service Request Number (PSRN)

When you received the PSR Approval email - please continue to Step 4.

In case your PSR was rejected – please do not send your camera to XIMEA.

6.2.4. Step 4 - Sending the camera to XIMEA

If possible, send the camera back in the original package. If not possible, please pack the camera in a way that it cannot be damaged during shipment and send it back as described in the PSR Approval email that you have received.

6.2.5. Step 5 - Waiting for Service Conclusion

Once we have received the camera, we will send you a notification. The XIMEA Service will then check the status of the camera that you have sent for a possible repair. Depending on warranty conditions, product status and agreement one of the following operations will be performed:

Operation	Repair costs paid by	Return delivery costs paid by
repaired in warranty	XIMEA	XIMEA
replaced in warranty	XIMEA	XIMEA
repaired for cost	Customer	Customer
not repaired and returned	-	Customer
not repaired and discarded if requested by customer	-	-

table 6-3, service operations overview

If the camera will be returned, you will receive the tracking number. In this case, please continue to step 6

6.2.6. STEP 6 - Waiting for return delivery

After you have received the return shipment, please confirm it by changing the status of the PSR to "Received by customer".

6.3. Safety instructions and precautions

Safety instructions and precautions are available at the following XIMEA webpage: [Safety instructions and precautions](#).

6.4. Warranty

Information about warranty is available at the following XIMEA webpage: [Warranty](#).

6.5. List Of Trademarks

List of Trademarks is available at the following XIMEA webpage: [List of Trademarks](#).

6.6. Standard Terms & Conditions of XIMEA GmbH

The Standard Terms and Conditions are available at the following XIMEA webpage: [General Terms and Conditions](#).

6.7. Copyright

All texts, pictures and graphics are protected by copyright and other laws protecting intellectual property. It is not permitted to copy or modify them for trade use or transfer, nor may they be used on websites.

6.8. Revision History

Version	Date	Notes
1.00	06/01/2017	Release candidate
1.01	07/07/2017	Added EF-mount section, minor changes
1.02	10/10/2017	Corrected typos and added handling guidelines
1.03	11/09/2017	Corrected specification CB500
1.04	01/18/2018	Added CB019xG-LX-X8G3; Added c-mount lens adapter Updated Triggered acquisition paragraph
1.05	02/23/2018	Corrected IO connector specification
1.06	08/21/2018	Corrected frame rate table for CB500
1.07	09/09/2019	Added CB160xG-LX-X8G3, CB262xG-GP-X8G3, CB654xG-GP-X8G3 Added power consumption for new electronics revision Added correct connection sequence Corrected frame rates
1.08	05/14/2020	Updated CB654xG-GP-X8G3 spectral properties Updated specification of non-isolated digital lines.
1.09	04/23/2021	Added CB262RG-GP-X8G3

Aegis Electronic Group
www.aegiselect.com

7. Glossary

Term /Abbreviation	Definition
ADC	Analog to Digital Converter
API	Application Programming Interface
AR (coating)	Anti-Reflex
B/W or B&W	Black and White
CCD	Charge-Coupled Device
CDS	Correlated double sampling
CMOS	Complementary Metal Oxide Semiconductor
DNC	Do not connect
DSNU	Dark Signal non-Uniformity
DR	Dynamic Range
EMC	Electro Magnetic Compatibility
ERS	Electronic rolling shutter
FPN	Fixed pattern noise
FPS	Frame per second
FWC	Full Well Capacity
GR	Global reset
GS	Global shutter
IR	Infra-Red
JTAG	Joint Test Action Group
LSB	Least Significant Bit
MIMR	Multiple integration multiple ROI
MSB	Most significant bit
MSL	Moisture sensitivity level
NA	Not Available
PCB	Printed Circuit Board (same as PWB)
PGA	Programmable gain amplifier
PRNU	Photo response non-uniformity
PWB	Printed Wiring Board (same as PCB)
RGB	Red Green Blue
ROI	Region of interest
Sat	Saturation value
SDK	Software Development Kit
SIMR	Single integration multiple ROI
SNR	Signal To Noise (ratio)
SPI	Serial peripheral interface
SW	Software
TBD	To be determined – some parameters require characterization
T _{int}	Integration time

8. list of figures

figure 2-1 xiB and xiB-64 camera with heat sinks.	10
figure 3-1, xiB camera with/without the optional EF-Mount Adapter	16
figure 3-2, xiB-64 camera with/without the optional C-Mount Adapter	16
figure 3-3, drawing demonstrating the mounting hole positions. Camera shown without EF mount.	17
figure 3-4, CMV12000-mono, color and NIR, quantum efficiency curve, ©CMOSIS	19
figure 3-5, dimensional drawing CB120xG-CM	20
figure 3-6, dimensional drawing CB120xG-CM, with EF-mount adapter	20
figure 3-7, CMV20000 mono and color, quantum efficiency curve, ©CMOSIS	23
figure 3-8, dimensional drawing CB200xG-CM with EF-mount adapter	24
figure 3-9, dimensional drawing CB200xG-CM with EF-mount adapter	24
figure 3-10 CMV50000 Quantum Efficiency ©CMOSIS	27
figure 3-11, dimensional drawing CB500xG-CM w/o EF-mount adapter	28
figure 3-12, dimensional drawing CB500xG-CM with EF-mount adapter	28
figure 3-13, LUX13HS quantum efficiency chart ©Luxima	31
figure 3-14, dimensional drawing CB013xG-LX-X8G3 without EF-mount adapter	32
figure 3-15, dimensional drawing CB013xG-LX-X8G3 with EF-mount adapter and fan cooler unit	32
figure 3-16, LUX19HS quantum efficiency chart ©Luxima	35
figure 3-17, dimensional drawing CB019xG-LX-X8G3 without EF-mount adapter	36
figure 3-18, dimensional drawing CB019xG-LX-X8G3 with EF-mount adapter and fan cooler unit	36
figure 3-19, CMV12000-mono, color and NIR, quantum efficiency curve, ©CMOSIS	39
figure 3-20, dimensional drawing CB120xG-CM-X8G3 without EF-mount adapter	40
figure 3-21, dimensional drawing CB120xG-CM-X8G3 with EF-mount adapter and fan cooler unit	40
figure 3-22, LUX160 quantum efficiency chart ©Luxima	43
figure 3-23, dimensional drawing CB160xG-LX-X8G3 without EF-mount adapter	44
figure 3-24, dimensional drawing CB160xG-LX-X8G3 with EF-mount adapter and fan cooler unit	44
figure 3-25, GMAX0505 quantum efficiency chart ©Gpixel	47
figure 3-26, dimensional drawing CB262xG-GP-X8G3 without EF-mount adapter	48
figure 3-27, dimensional drawing CB262xG-GP-X8G3 with EF-mount adapter and fan cooler unit	48
figure 3-28, GMAX3265 quantum efficiency chart ©Gpixel	51
figure 3-29, dimensional drawing CB654xG-GP-X8G3 without EF-mount adapter	52
figure 3-30, dimensional drawing CB654xG-GP-X8G3 with EF-mount adapter and fan cooler unit	52
figure 3-31, position status LEDs	54
figure 3-32, position iPass™ connector	55
figure 3-33, position GPIO + power connector	56
figure 3-34, xiB IO connector pinout	56
figure 3-35, xiB-64 IO connector pinout	57
figure 3-36 Recommended twisted pair configuration, xiB	58
figure 3-37, digital input, interface schematic	60
figure 3-38, digital input, interface wiring	60
figure 3-39, digital output, interface schematic	62
figure 3-40, digital output transfer characteristics	62
figure 3-41, Connecting Digital OUTPUT to a NPN-compatible PLC device input (biased)	63
figure 3-42, Connecting Digital OUTPUT to a NPN-compatible PLC device input - more bidirectional inputs used	63
figure 3-43, Connecting Digital OUTPUT to a NPN-compatible PLC device - single input	63
figure 3-44, Connecting Digital OUTPUT to a PNP-compatible device	64
figure 3-45, LED Driving	65
figure 3-46, Inductive load (Relay) Driving (inverted logic)	66

figure 3-47, Inductive load (Relay) Driving (non-inverted logic)	66
figure 3-48, non isolated input/output, interface schematic	68
figure 3-48, non isolated input/output, interface schematic	69
figure 3-50, CBL-PEX4-COP-xMO PCIe Gen.2 x4, copper cable	70
figure 3-51, CBL-PEX4-FIB-xMO, PCIe Gen.3 x4, fiber optics cable	70
figure 3-52, CBL-PEX8-FIB-xMO, PCIe Gen.3 x8, fiber optics cable	70
figure 3-53 PEX4-G2-COP PCIe Gen.2 x4 extender host adapter for copper cables	71
figure 3-54, drawing sync cable – current revisions of this cable are 3m in length	72
figure 3-55, wiring sync cable CBL-CB-POWER-SYNC-3MO	72
figure 3-56, wiring sync cable CBL-CB-POWER-SYNC-3MO (legacy)	73
figure 3-57 drawing sync cable, current revisions of this cable are 3m in length	74
figure 3-58 Wiring diagram CBL-MT-POWER-SYNC-3MO	74
figure 3-59, mounting tripod adapter	75
figure 3-60, mounting fan cooling element CB-X8G3-FAN-COOLER	76
figure 3-61, rear mounting holes	76
figure 3-62, mounting cooling element MECH-60MM-HEATSINK	77
figure 3-63, mounting lens adapter with CANON EF-mount (MECH-60MM-EF-ADAPTER)	78
figure 3-64, mounting lens adapter with C-mount (LA-C-MNT-60MM-KIT)	78
figure 4-1, acquisition mode - free run	83
figure 4-2, acquisition mode – triggered with overlap	84
figure 4-3, triggered burst of frames – frame burst start, number of frames in burst set to 3	85
figure 4-4, triggered burst of frames – frame burst active	85
figure 4-5, Exposure defined by trigger pulse length	85
figure 4-6, image saturation example without HDR	88
figure 4-7, image example without HDR	88
figure 4-8, image saturation example with HDR	89
figure 4-9, image example with HDR	89
figure 4-10, HDR - approx. logarithmic saturation curve	90
figure 5-1, CamTool Layout	92
figure 5-2, XIMEA Windows Software Package installation - 1	95
figure 5-3, XIMEA Windows Software Package installation - 2	96
figure 5-4, XIMEA Windows Software Package installation - 3	96
figure 5-5, xiAPI installation, Windows - 4	97
figure 5-6, xiAPI installation, Windows - 5	97
figure 5-7, XIMEA Linux Software Package installation - 1	98
figure 5-8, XIMEA Linux Software Package installation - 2	99
figure 5-9, XIMEA macOS Software Package installation - 1	100
figure 5-10, xiAPI installation, MacOS - 2	101
figure 5-11, GPIO - schematic	104
figure 5-12, xiCOP	106

9. list of tables

table 2-1, advantages	10
table 2-2, common features	11
table 2-3, models overview	13
table 2-4, accessories	14
table 2-5, assembly options	14
table 3-1, environment	15
table 3-2, firmware / API features	15
table 3-3, CB120xG-CM, sensor and camera parameters	18
table 3-4, CB120xG-CM, standard readout modes	19
table 3-5, sensor features available	21
table 3-6, CB200xG-CM, sensor and camera parameters	22
table 3-7, CB200xG-CM, standard readout modes	23
table 3-8, sensor features available	25
table 3-9, CB500xG-CM, sensor and camera parameters	26
table 3-10, CB500xG-CM, standard readout modes	27
table 3-11, sensor features available	29
table 3-12, CB013xG-LX-X8G3, sensor and camera parameters	30
table 3-13, CB013xG-LX-X8G3, standard readout modes	30
table 3-14, sensor features available	33
table 3-15, CB019xG-LX-X8G3, sensor and camera parameters	34
table 3-16, CB019xG-LX-X8G3, standard readout modes	34
table 3-17, sensor features available	37
table 3-18, CB120xG-CM-X8G3, sensor and camera parameters	38
table 3-19, CB120xG-CM-X8G3, standard readout modes	39
table 3-20, sensor features available	41
table 3-21, CB160xG-LX-X8G3, sensor and camera parameters	42
table 3-22, CB160xG-LX-X8G3, standard readout modes	42
table 3-23, sensor features available	45
table 3-24, CB262xG-GP-X8G3, sensor and camera parameters	46
table 3-25, CB262xG-GP-X8G3, standard readout modes	47
table 3-26, sensor features available	49
table 3-27, CB654xG-GP-X8G3, sensor and camera parameters	50
table 3-28, CB654xG-GP-X8G3, standard readout modes	51
table 3-29, sensor features available	53
table 3-30, LED output description after camera is opened in API	54
table 3-31, LED output description during xiB camera power up	54
table 3-32, LED output description during xiB-64 camera power up	55
table 3-33, PCI express mating connector description	55
table 3-34, GPIO mating connector description	56
table 3-35, xiB I/O connector Pin Assignment	57
table 3-36, xiB-64 I/O connector Pin Assignment	57
table 3-37, xiB and xiB-64 IO pin to API index assignment	58
table 3-38, Optically isolated digital input, general info	59
table 3-39, digital info, signal levels	59
table 3-40, digital input, timing	61
table 3-41, Optically isolated digital output, general info	61
table 3-42, digital output, LED driving	65

table 3-43, digital output, wiring examples	67
table 3-44, digital output, typical timing	67
table 3-45, digital output, current depending timing	67
Table 3-46, General info for non-isolated digital in/out trigger lines.	68
Table 3-47, General info for non-isolated digital in/out trigger lines.	69
table 3-48, digital output, typical timing	69
table 3-49, host adapter cards	71
table 3-50, sync + power cable, components	72
table 3-51, sync + power cable, components	74
table 4-1, image formats,	82
table 6-1, use xiCOP before contacting technical support	107
table 6-2, interface depending transfer rates	108
table 6-3, service operations overview	109

Aegis Electronic Group
www.aegiselect.com