



## **MX377** | Cooled PCIe sCMOS cameras

### Camera Info

Version 0.21, 05/06/2025

# Table of Contents

1.	General description .....	5
2.	Sensor GSENSE6060 .....	7
2.1.	Sensor structure .....	7
2.2.	Sensor grades .....	8
2.3.	Pixel structure .....	9
2.3.1.	Low- and High Gain readout .....	10
2.3.2.	HDR modes using LG and HG data (Standard HDR modes described in the sensor specs) .....	10
2.4.	Noise reduction .....	11
2.4.1.	Correlated double sampling .....	11
2.4.2.	Correlated multi sampling .....	11
2.5.	Quantum efficiency .....	12
2.5.1.	FSI .....	12
2.5.2.	BSI .....	12
3.	Camera readout modes .....	13
3.1.	STD modes .....	13
3.1.1.	STD mode 1: 12-bit, LG .....	14
3.1.2.	STD mode 2: 14-bit, LG .....	14
3.1.3.	STD mode 3: 12-bit, HG .....	15
3.1.4.	STD mode 4: 14-bit, HG .....	15
3.2.	CMS modes .....	16
3.2.1.	CMS mode 1: 2-CMS, 12-bit, LG .....	17
3.2.2.	CMS mode 2: 2-CMS, 14-bit, LG .....	17
3.2.3.	CMS mode 3: 2-CMS, 12-bit, HG .....	18
3.2.4.	CMS mode 4: 2-CMS, 14-bit, HG .....	18
3.2.5.	CMS mode 5: 4-CMS, 12-bit, LG .....	19
3.2.6.	CMS mode 6: 4-CMS, 14-bit, LG .....	19
3.2.7.	CMS mode 7: 4-CMS, 12-bit, HG .....	20
3.2.8.	CMS mode 8: 4-CMS, 14-bit, HG .....	20
3.3.	HDR modes .....	21
3.3.1.	HDR modes using LG and HG data (Standard HDR modes described in the sensor specs) .....	21
3.3.2.	12-bit HDR mode, LG and HG .....	21
3.3.3.	12-bit HDR 2-CMS mode, LG and HG .....	21
3.3.4.	12-bit HDR mode, LG or HG .....	22
3.3.5.	Modes .....	22
3.3.5.1.	HDR mode 1: 12-bit, HG + LG .....	23
3.3.5.2.	HDR mode 2: 12-bit, LG .....	23
3.3.5.3.	HDR mode 3: 12-bit, HG .....	24
3.3.5.4.	HDR mode 4: 2-CMS, 12-bit, HG + LG .....	25
3.3.5.5.	HDR mode 5: 14-bit, LG .....	26
3.3.5.6.	HDR mode 6: 14-bit, HG .....	26
4.	Camera settings .....	27
4.1.	mode settings - API .....	27
4.2.	mode settings - factory presets (API) .....	29
4.3.	mode settings - xiCamTool .....	30

4.4.	Gain settings (API).....	30
4.5.	Sensor cooling.....	30
4.5.1.	Sensor cooling – API.....	30
4.5.2.	Sensor cooling – xiCamTool .....	31
5.	Measurements .....	32
5.1.	Frame rates.....	32
5.2.	Rolling shutter - Sensor readout time .....	32
5.3.	FWC / total noise (preliminary measurements).....	33
5.4.	Power consumption / housing temperature (preliminary measurements).....	34
5.4.1.	Air cooled camera.....	34
5.4.2.	Liquid cooled camera.....	34
5.5.	Dark current.....	35
5.6.	Total noise, spatial distribution.....	36
5.7.	Sensor flatness.....	37
6.	MX377 housing.....	38
6.1.	Front flange options .....	38
6.2.	Camera dimension.....	40
6.2.1.	Front view .....	40
6.2.2.	Distances between sensor surface (focal plane) and camera front / filter glass.....	41
6.2.3.	Camera dimensions – Air cooled version .....	42
6.2.4.	Camera dimensions – Liquid cooled version.....	42
6.3.	Water cooling .....	43
6.3.1.	Push-in fittings .....	43
6.3.2.	Connecting and disconnecting the tubes .....	44
6.3.3.	Pressure loss with longer water tubes .....	45
7.	Data connection .....	46
7.1.	Camera connector .....	46
7.2.	Host adapter.....	46
7.3.	MTP cable.....	46
8.	MX377 trigger-/IO-system .....	47
8.1.	Location.....	47
8.2.	Connector .....	47
8.3.	IO Connector Pinning .....	47
8.4.	Non-isolated digital Input/Output lines (INOUT).....	48
8.5.	Optically isolated Digital Input (IN) .....	48
8.6.	Optically isolated Digital Output (OUT) .....	49
8.7.	Trigger cable CBL-MX377-SYNC-3M0 .....	50
8.7.1.	White (XIMEA pre-production).....	50
8.7.2.	Black (series production) .....	51
9.	MX377 power connector.....	52
9.1.	Location.....	52
9.2.	Connector .....	52
10.	Quickstart Guide.....	53
10.1.	Hardware Setup.....	53
10.1.1.	Essential Components.....	53
10.1.2.	Connecting the Components.....	53

10.2. Installing the XIMEA Software Package.....	54
10.3. Getting Images from Your Camera in CamTool.....	54
10.4. Basic Settings in CamTool.....	54
11. MX377 system overview.....	55
11.1. Accessories / models.....	55
12. Additional info.....	57
13. Revision history.....	58

Aegis Electronic Group  
www.aegiselect.com

## 1. General description

The MX377 are cooled cameras with PCIe interface and Gpixel GSENSE6060 sensors

### Facts

- Gpixel GSENSE6060 and GSENSE6060BSI sensors
- 61 x 61 mm large format sCMOS
- 37.7 Mpix, 6144 (H) x 6144 (V), 10µm pixels
- 95% QE from backside illuminated variants
- Native HDR, up to 90dB, 16 bits
- Full well 110ke-, Readout noise 3e-
- Low dark current, cooling down to -25°C
- PCIe Gen3, with 4 lanes interface: 32 Gbps of raw bandwidth
- >46 fps in full resolution, STD mode

### Features

- CCD-like performance
- CMOS data rates
- Super compact form factor compared to sensor size
- Multiple sensor grades for best price/performance ratio
- Peltier with air or liquid cooled backend options
- MTP fiber interface with up to 100m cable length
- No frame grabber required, DMA transfer with no CPU load
- Direct GPU transfer with selected NVIDIA boards under Linux
- Data transmission with functionally zero latency
- Flexible GPIO with opto-isolated and TTL options
- Rugged aluminum alloy, copper- and steel-based CNC machined housing

### Extending prevailing performance characteristics for image quality

Featuring one of the largest sCMOS sensors available today: The Gpixel GSENSE6060 with 37.7 million 10 µm pixels offers imaging performance on par with the best CCDs in a high-speed CMOS architecture.

Existing CCDs have thus far remained the go-to technology for scientific measurements, in spite of being unable to match the pace of CMOS innovation. The MX377 camera delivers scientific imaging capabilities with high dynamic range and low noise – at high speed. The camera was also designed with cooling for low light level applications. Two versions of the GSENSE6060 sensor can be provided, frontside (FSI) or backside (BSI) illuminated models, with several grades.

With the sCMOS BSI sensor, the camera reaches a maximum quantum efficiency of 95 percent. Due to the large sensor format of 60 x 60 mm, 6 k by 6 k resolution and 10 µm pixel size, it is a perfect fit for applications demanding a medium to large format sensor. The output signal from the GSENSE6060 pixels is processed by two readout amplifiers (hi and lo) allowing an HDR readout (2 x 12- or 2 x 14-bit ADC) with up to 90 dB dynamic range. All this with a frame rate of up to 46 fps and a full well capacity of 110 ke-.

### Groundbreaking efficiency in a compact, cooled package

Utilizing a multi-lane PCIe interface which can deliver data at the maximum rates the sensor is capable of. The PCIe interface delivers data with near zero latency from the sensor to the operating computer's RAM (or GPU) for optimum processing capability and speed. The sensor itself has several groundbreaking properties with high dynamic range (FWC close what is expected from CCDs) and dual amplifiers for simultaneous integration of the imagery to deliver high bit depth information on the contents of the image.

The MX377 camera model was primarily designed for astronomy and space situational awareness (SSA) applications. In addition, its extraordinary performance makes it a perfect fit for other fields of material and life science like high energy physics, medical imaging, biological research, TEM and others. These and other applications will benefit from the combination of high-speed CMOS performance with CCD like data quality in dynamic range and noise, further improved by the availability of either air or water-based cooling options to reduce thermal noise for long exposures.

This large format sensor and all its capabilities comes in a very compact package, compatible with M95 lenses. The compact CNC machined camera housing is designed with XIMEA's core principles of remaining small and fast in mind.

Aegis Electronic Group  
[www.aegiselect.com](http://www.aegiselect.com)

## 2. Sensor GSENSE6060

### 2.1. Sensor structure

We use two different sensors:

- GSENSE6060: frontside illuminated (FSI) scientific CMOS (sCMOS)
- GSENSE6060BSI: backside illuminated (BSI) sCMOS

Both sensors (FSI and BSI) support 12- and 14-bit readout modes. The sCMOS sensors offer a two analog-digital-converters (ADC) architecture. The signals from each pixel can be sampled by two gain modes simultaneously:

- high gain (HG), optimized for low readout noise.
- low gain (LG), optimized for high full well capacity.

GSENSE6060 and GSENSE6060BSI are rolling shutter sensors.

The structure of the sensor and the readout logic is simplified:

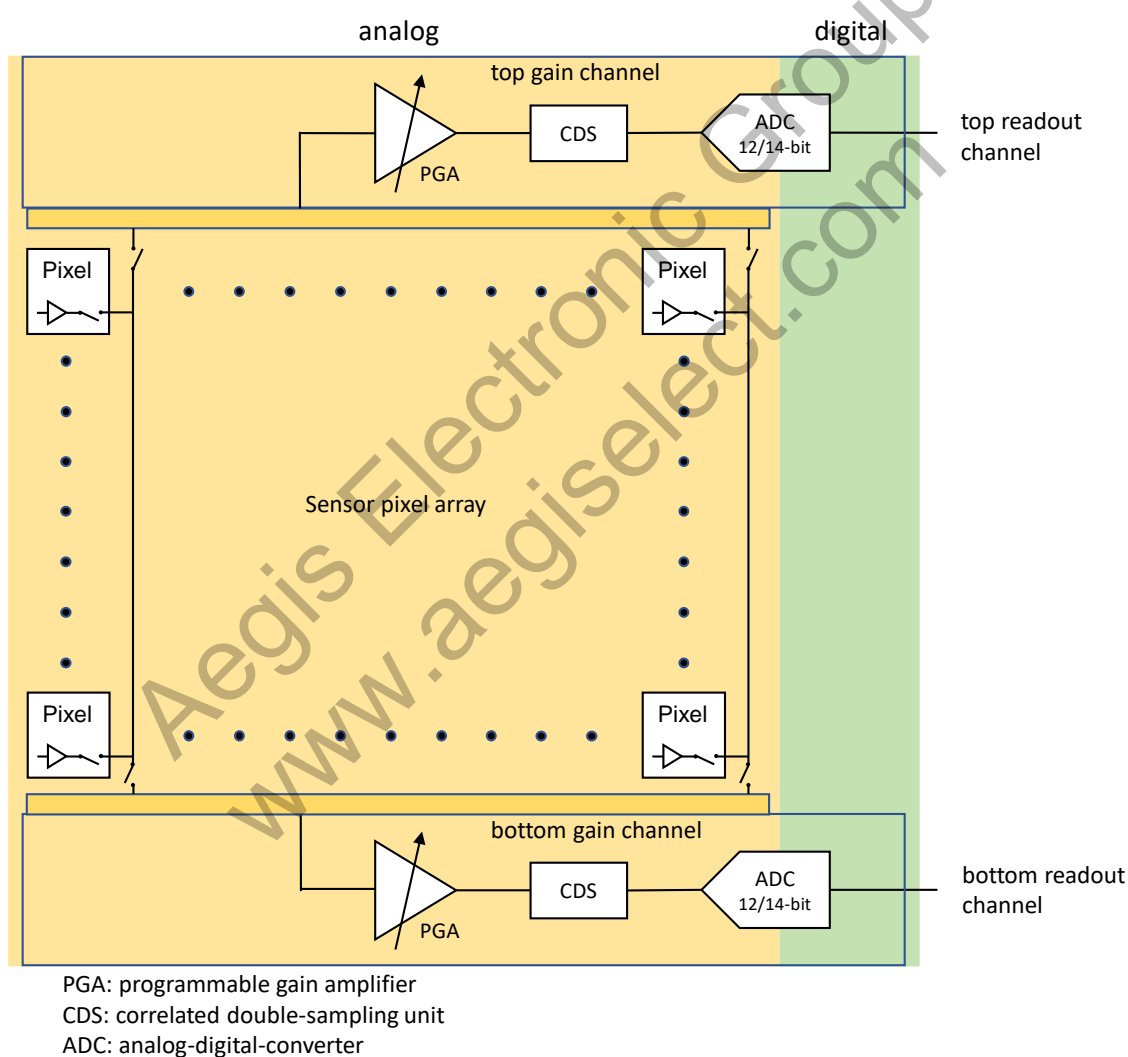

The GSENSE6060 sensor has two readout channels (top and bottom gain channels in the figure above) which are used differently depending on the operation mode.

In the following we use the simplified representation:

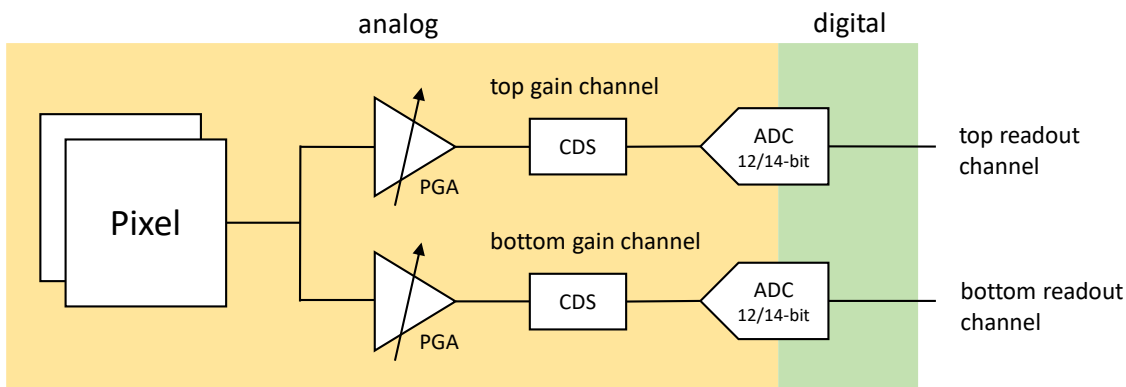

## 2.2. Sensor grades

We offer sensors with different degrees: Grade 0 (best grade) and Grade 1, which differ in the permissible pixel defects:

Defect limits of GSENSE6060 (any Defects on the glass lid are excluded)

	Grade 0	Grade 1
Total Defect Pixel	500	1000
Defect Column + Defect Row	2	6

Defect limits of GSENSE6060BSI (any Defects on the glass lid are excluded)

	Grade 0	Grade 1
Total Defect Pixel	800	1200
Defect Column + Defect Row	2	6

Defect rows / columns can be adjacent to each other in all grades.

### Defect definitions:

Defect	Description
Defect pixel in Half-saturation image	Any pixel deviates more than 30% from the mean value of the Half-saturation image (either HG or LG channel)
Defect pixel in Saturation image	Any pixel deviates more than 30% from the mean value of the Saturation image (LG channel only)
Total Defect Pixel	The total number of non-overlapping defect pixels in Half-saturation image and Saturation image.
Defect Row	Any row with its mean value deviating more than 10% from the mean value of the Half-saturation image (either HG or LG channel). Any row with its mean value deviating more than 10% from Saturation image of the LG channel. Or a row with more than 150 Defect pixels;
Defect Column	Any column with its mean value deviating more than 10% from the mean value of the Half-saturation images (either HG or LG channel). Any column with its mean value deviating more than 10% from Saturation image of the LG channel. Or a column with more than 150 Defect pixels.

## 2.3. Pixel structure

The basic structure is a 4T (four transistor) pixel architecture. The transistors are so-called CMOS (complementary metal–oxide–semiconductor) transistors and give the CMOS image sensors their name.

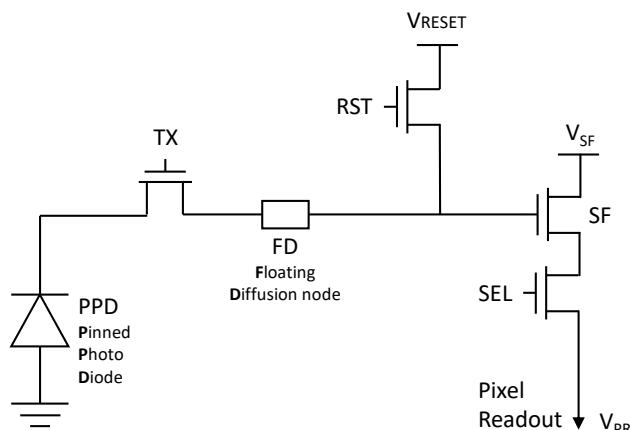

The pixel consists of

- photodetector (PPD)
- floating diffusion unit (FD)
- transfer gate (TX)
- reset gate (RST)
- selection gate (SEL)
- readout transistor (source follower, SF)

The transistors TX, RST and SEL are used as switches. The transistor SF is used as an amplifier, small changes in the input voltage (from the FD) produce large changes in the output voltage ( $V_{SF}$  is the supply voltage for this amplification).

Charge is collected by the photo diode while TX is OFF and transferred to the floating diffusion unit by turning TX ON at the end of the exposure time.

The charge collecting unit (photo diode) and the readout part are separated. That structure allows (low noise) intra-pixel operation before and during the readout (without connection to the photo diode). Intra pixel operation is e.g. storing the charge in the FD, or changing the capacitance of the FD (see [2.3.1 Low- and High Gain readout](#)).

The ratio of the electrons generated in the photodiode and the voltage generated in the pixel, which controls the readout transistor SF, depends on the capacitance of the floating diffusion unit.

$$V = \frac{1}{c} q$$

$q$  : collected charge

$C$  : capacitance where the charge is stored before/during readout

A large capacity results in a low conversion factor but supports a high full well capacity

A small capacity has a high conversion factor and lower FWC but higher sensitivity to small amounts of charge and results in lower noise.

The noise of an image sensor is (simplified) given in units of electrons. The components in the analog voltage domain generate noise of the voltage. A high factor in the conversion from electrons to voltage (small capacitance or small FWC = high gain) means that even small electrical charges in the photodiode generate higher signals (voltages) that exceed the component noise. This means lower sensor noise.

### 2.3.1. Low- and High Gain readout

The GSENSE6060/6060BSI realize two different capacity values in the floating diffusion node:

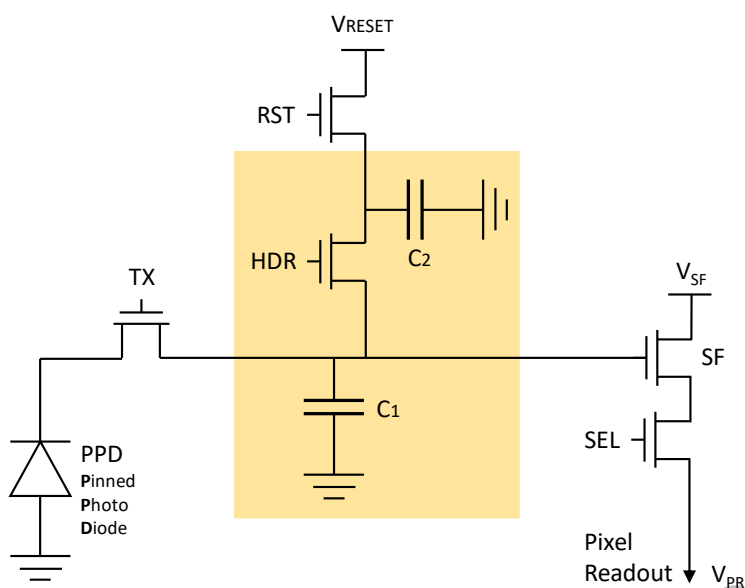

Setting HDR to ON realizes a large capacity  $C1 + C2$  (low gain = LG readout).

Otherwise only the smaller capacity  $C1$  is used to store the collected charge (high gain = HG readout).

### 2.3.2. HDR modes using LG and HG data (Standard HDR modes described in the sensor specs)

In these modes the LG and HG values from the pixel are read during one readout. The LG part is processed by the top gain channel, the HG part by the bottom gain channel.

To achieve that HG and LG values are available in one readout cycle, the readout is divided into two phases. The readout status of the pixel and the target (gain channels) is changed from phase 1 to phase 2.

For this the status of HDR is changed between phase 1 and phase 2:

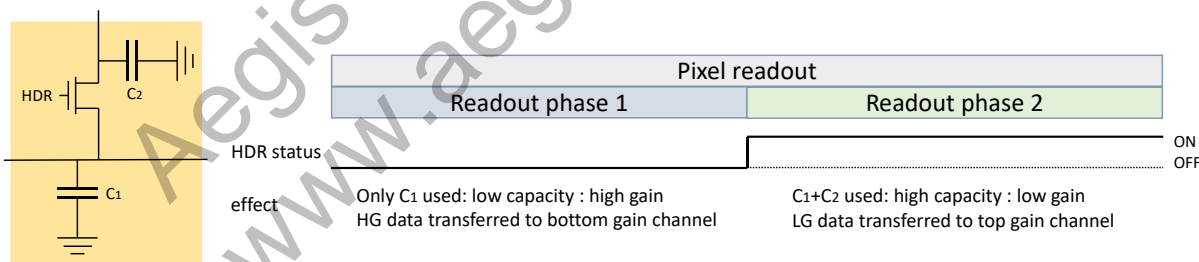

## 2.4. Noise reduction

Nearly all components in a sensor have noise characteristics. The main task, especially in a Scientific CMOS sensor, is to implement noise reduction methods to generate low-noise images and thus, for example, to enable long exposure times.

### 2.4.1. Correlated double sampling

Many modern sensors offer pre-amplification of the generated charge read out by the sensor in the analog domain.

The aim of noise reduction is to measure the charge generated by the pixel during exposure as accurately as possible, and to reduce the signal noise of e.g. the floating diffusion unit (FD) and the analog preamplifiers.

For this purpose, many modern sensors have a so-called correlated double sampling (CDS) unit integrated in the analog domain.

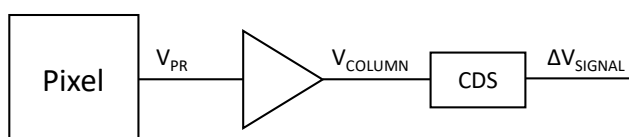

The voltage  $V_{PR}$  read out from the pixel is amplified by the analog signal amplifiers to the voltage  $V_{COLUMN}$ .

A downstream CDS measures the difference from the two voltage values after reset (of the floating diffusion unit [FD]) and after transfer of the charge generated by the pixel (photo diode).

Thus, the noise values of the units involved can be compensated.

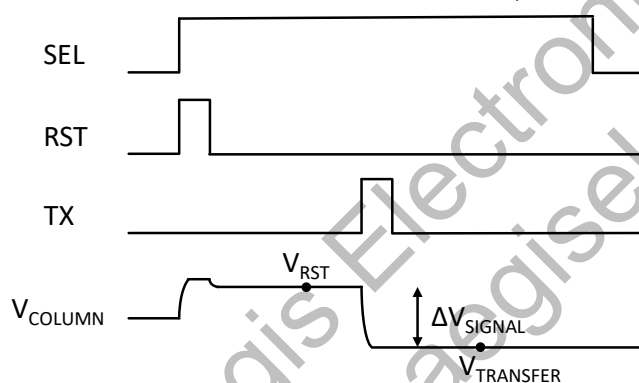

### 2.4.2. Correlated multi sampling

sCMOS sensors also offer another sampling method, called correlated multi sampling (CMS).

The basic idea is that the generated charge ( $\Delta V_{SIGNAL}$ ) is measured several times and averaged over them.

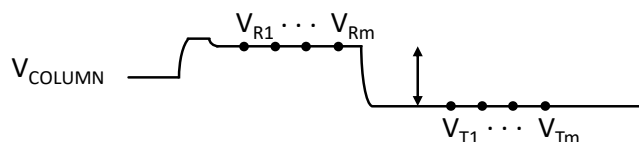

The sensors GSENSE6060/6060BSI offer CMS with 2 or 4 measurements of the reset and signal levels in different modes CMS (2-CMS, 4-CMS).

The use of the CMS modes reduces the noise values of the sensor and thus increases the signal-to-noise ratio (SNR), but at the price of a correspondingly reduced frame rate, since the images must be read out from the sensor several times. See details in the description of the different modes (see below).

## 2.5. Quantum efficiency

### 2.5.1. FSI

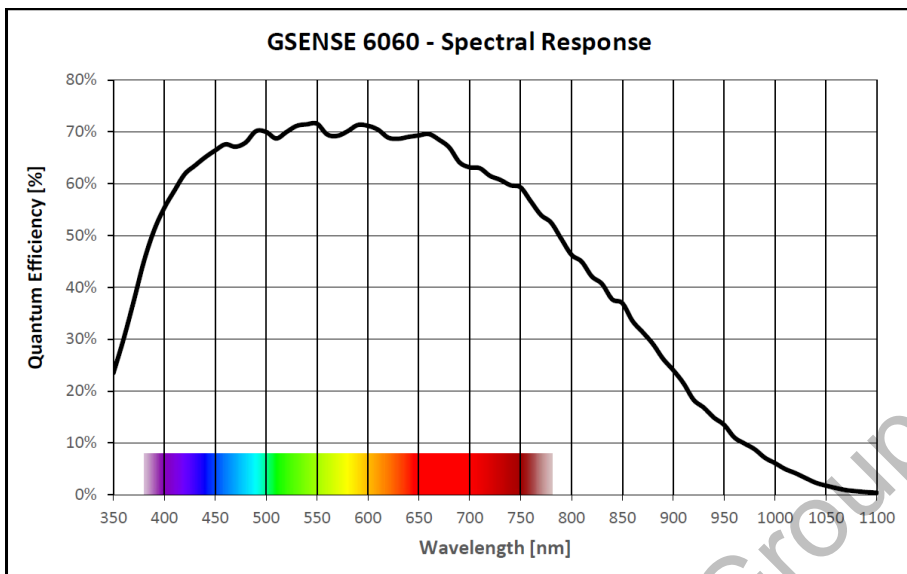

### 2.5.2. BSI

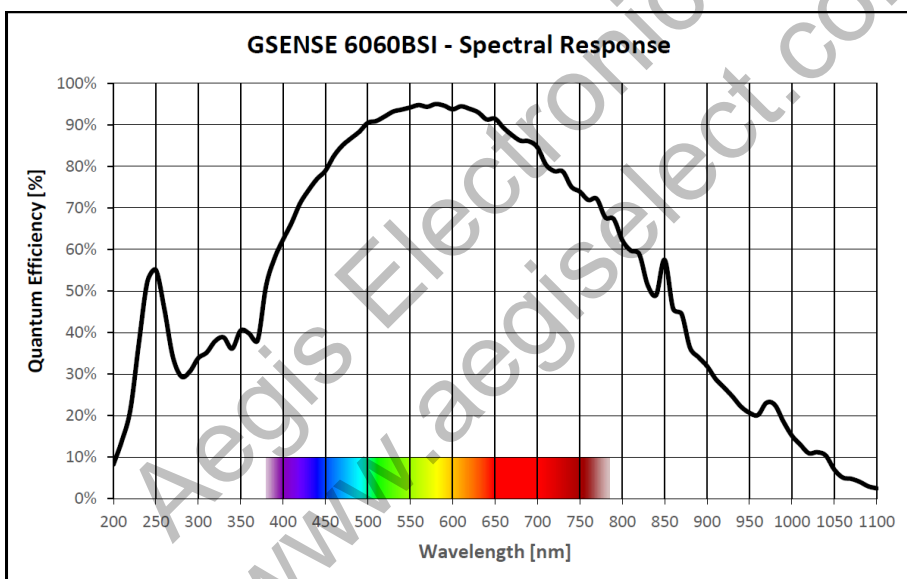

### 3. Camera readout modes

The MX377 supports different modes:

- Standard (STD), 12- and 14-bit, high-gain or low-gain
- 2x correlated Multiple Sampling (2-CMS), 12- and 14-bit, high-gain or low-gain
- 4x correlated Multiple Sampling (4-CMS), 12- and 14-bit, high-gain or low-gain
- HDR, 12-bit, high- and low-gain
- HDR, 12-bit, high-gain or low-gain
- HDR / 2-CMS, 12-bit high- and low-gain

#### Data output (transport layer)

The camera delivers a 16-bit value (unsigned short int) as standard in almost all modes described below.

Only in the two modes

- STD mode 12-STD-L
- STD mode 12-STD-H

12-bit values are transmitted.

#### ADC bit depth

The ADC can be read out either in 12- or 14-bit. The sensor supports both options in all modes, except in HDR modes using LG and HG data.

In any case both readout channels are operated in the identical ADC quantization depth.

#### 3.1. STD modes

In all standard modes the top gain channel is connected to the odd rows of the sensor and the bottom channel to the even rows.

The frame rate is higher in these modes because two image rows are read in parallel.

Both channels use the same gain value which can be controlled by the API parameter XI\_PRM\_GAIN.

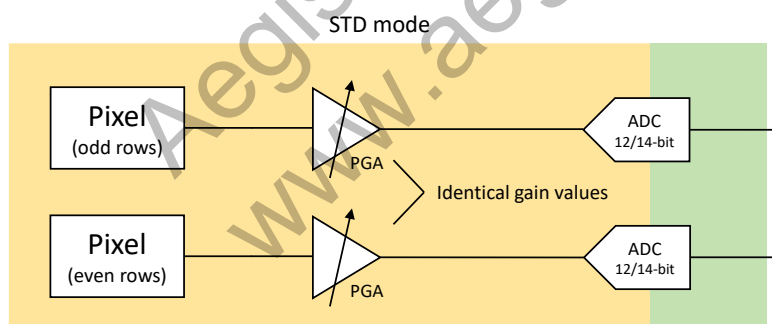

All combinations of ADC width and LG/HG readout are supported:

ADC depth	HG/LG readout	MX377 mode
12	LG	STD mode 1: 12-STD-L
14	LG	STD mode 2: 14-STD-L
12	HG	STD mode 3: 12-STD-H
14	HG	STD mode 4: 14-STD-H

The sensor data is transferred within the camera to the FPGA, where it is sequenced and transmitted via the PCIe interface.

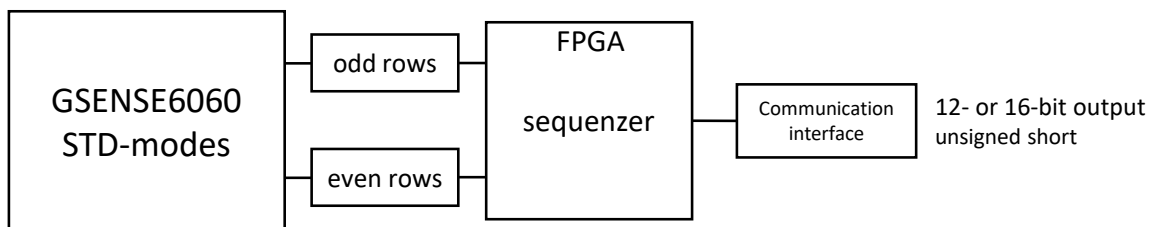

### 3.1.1. STD mode 1: 12-bit, LG

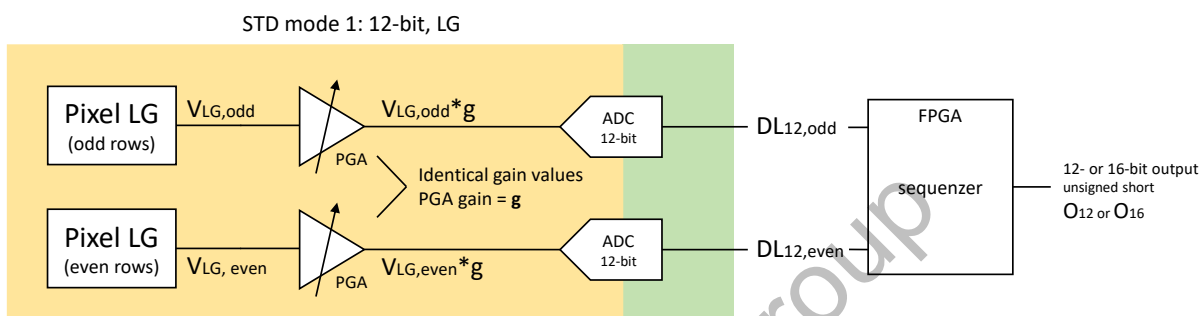

$V_{LG}$  : analog LG values from pixel

$V_{LG} * g$  : analog LG values amplified by PGA gain  $g$

$DL_{12}$  : digital 12-bit LG values

The sequencer in the FPGA sorts the lines correctly.

If a 12-bit camera readout is used, the  $DL_{12}$  values are transferred as  $O_{12}$ .

If a 16-bit camera readout is used, the  $DL_{12}$  values are shifted by 4-bit:  $O_{16} = DL_{12} * 16$ .

### 3.1.2. STD mode 2: 14-bit, LG

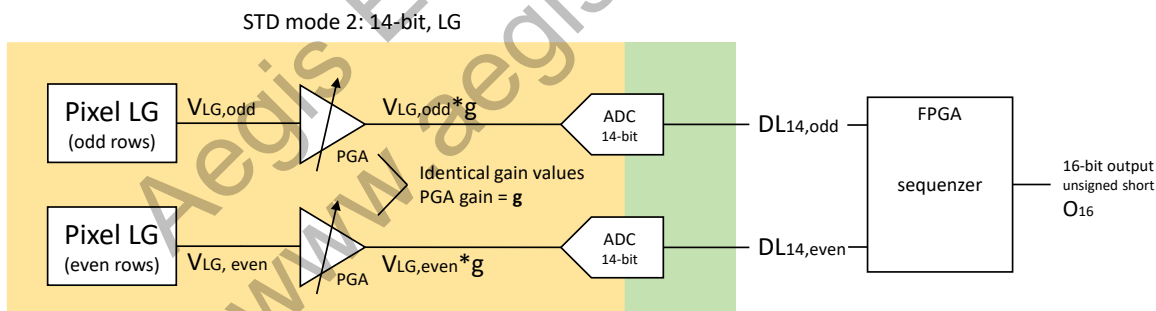

$V_{LG}$  : analog LG values from pixel

$V_{LG} * g$  : analog LG values amplified by PGA gain  $g$

$DL_{14}$  : digital 14-bit LG values

The sequencer in the FPGA sorts the lines correctly.

To calculate the 16-bit camera readout value, the  $DL_{14}$  values are shifted by 2-bit:  $O_{16} = DL_{14} * 4$ .

### 3.1.3. STD mode 3: 12-bit, HG

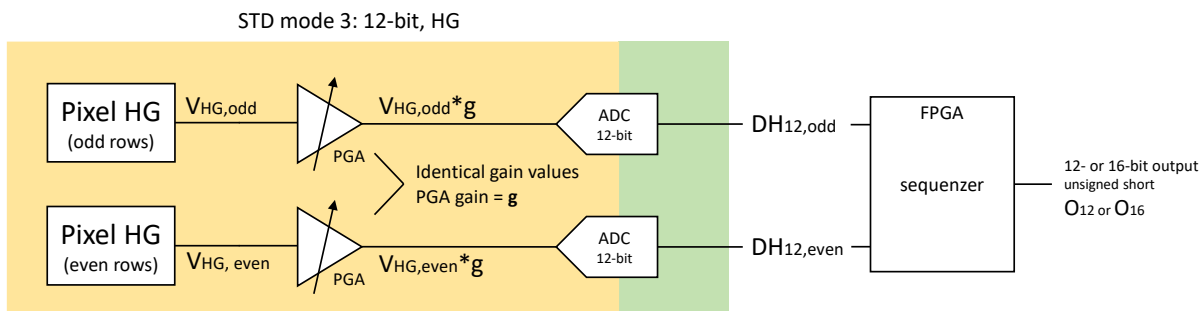

$V_{HG}$  : analog HG values from pixel

$V_{HG} * g$  : analog HG values amplified by PGA gain  $g$

$DH_{12}$  : digital 12-bit HG values

The sequencer in the FPGA sorts the lines correctly.

If a 12-bit camera readout is used, the  $DH_{12}$  values are transferred as  $O_{12}$ .

If a 16-bit camera readout is used, the  $DH_{12}$  values are shifted by 4-bit:  $O_{16} = DH_{12} * 16$ .

### 3.1.4. STD mode 4: 14-bit, HG

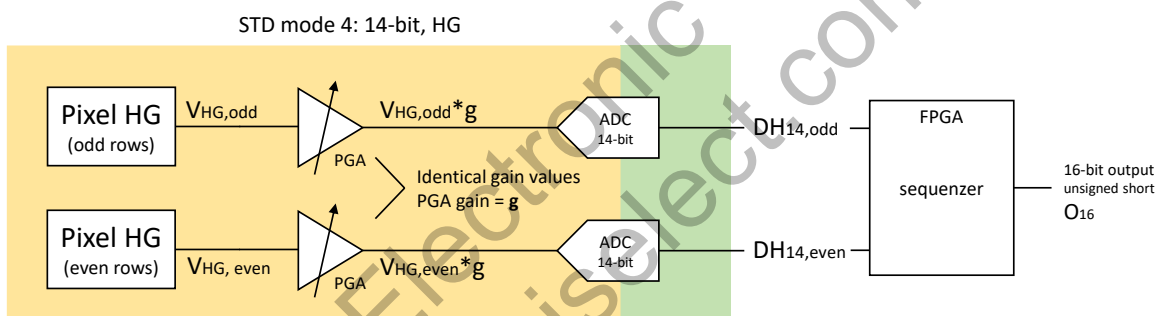

$V_{HG}$  : analog HG values from pixel

$V_{HG} * g$  : analog HG values amplified by PGA gain  $g$

$DH_{14}$  : digital 14-bit HG values

The sequencer in the FPGA sorts the lines correctly.

To calculate the 16-bit camera readout value, the  $DH_{14}$  values are shifted by 2-bit:  $O_{16} = DH_{14} * 4$ .

### 3.2. CMS modes

In CMS mode, the reset and pixel output are sampled multiple times and summed up for pixel-related noise suppression.

In 2-CMS modes the image data is sampled twice, in 4-CMS-modes the image data is sampled four times.

Both channels use the same gain value which can be controlled by the API parameter XI\_PRM\_GAIN.

In 2-CMS mode the pixel data is sampled twice, using both gain channels in parallel. The identical image is therefore sampled and read out two times, one time via top and a second time via bottom readout channel.

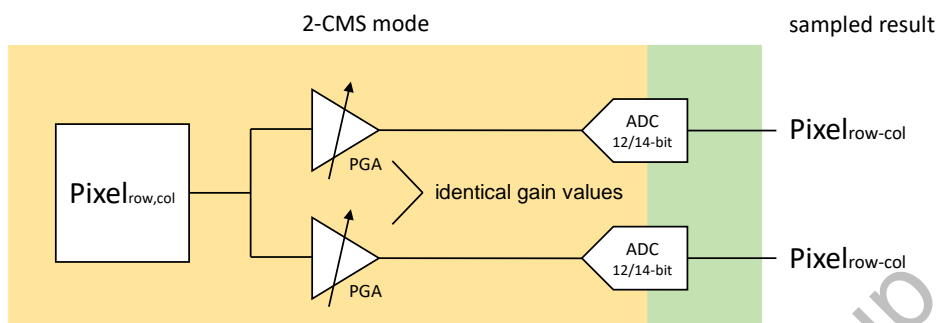

In 4-CMS mode the pixel data is sampled four times, using both gain channels in parallel. The identical image is therefore sampled and read out four times, twice via top and a twice via bottom readout channel.

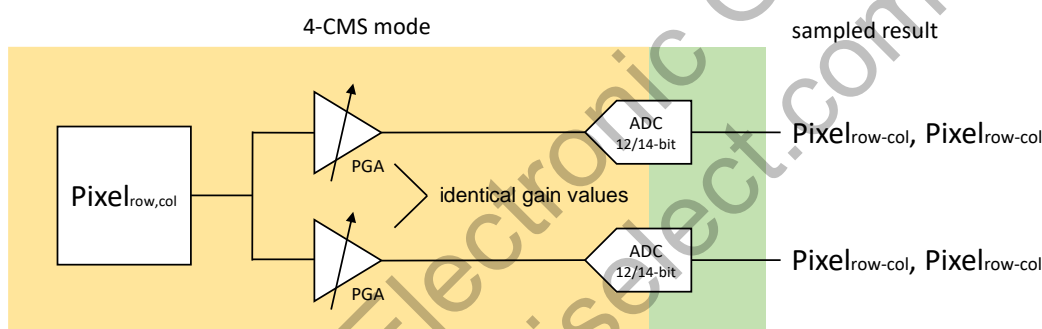

All combinations of ADC width, LG/HG readout and number of samplings are supported:

Samplings	ADC depth	HG/LG readout	MX377 mode
2-CMS	12	LG	CMS mode 1: 2-12-CMS-S-L
2-CMS	14	LG	CMS mode 2: 2-14-CMS-S-L
2-CMS	12	HG	CMS mode 3: 2-12-CMS-S-H
2-CMS	14	HG	CMS mode 4: 2-14-CMS-S-H
4-CMS	12	LG	CMS mode 5: 4-12-CMS-S-L
4-CMS	14	LG	CMS mode 6: 4-14-CMS-S-L
4-CMS	12	HG	CMS mode 7: 4-12-CMS-S-H
4-CMS	14	HG	CMS mode 8: 4-14-CMS-S-H

The image data is transferred within the camera twice or 4 times to the FPGA, where they are summed (and effectively averaged) and transmitted via the PCIe interface.

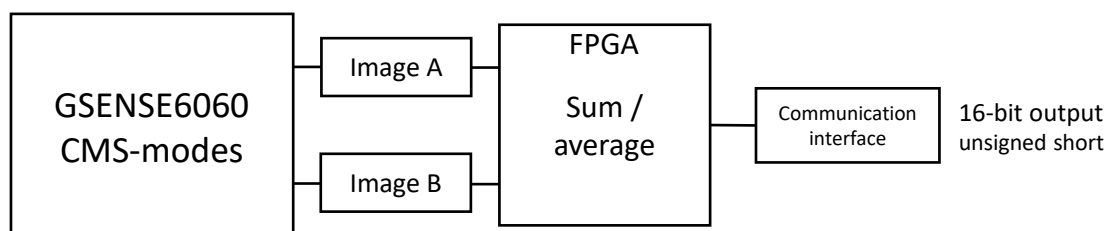

### 3.2.1. CMS mode 1: 2-CMS, 12-bit, LG

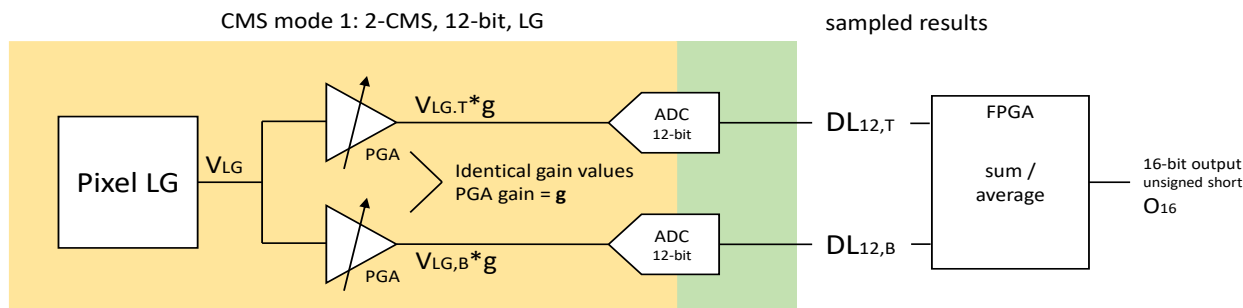

$V_{LG}$  : analog LG values from pixel

$V_{LG,T} * g$  : analog LG values amplified by PGA gain  $g$ , top gain channel

$V_{LG,B} * g$  : analog LG values amplified by PGA gain  $g$ , bottom gain channel

$DL_{12,T}$  : digital 12-bit LG values, top gain channel

$DL_{12,B}$  : digital 12-bit LG values, bottom gain channel

The FPGA adds both pictures.

The 16-bit output result is calculated as

$$O_{16} = (DL_{12,T} + DL_{12,B}) * 8$$

### 3.2.2. CMS mode 2: 2-CMS, 14-bit, LG

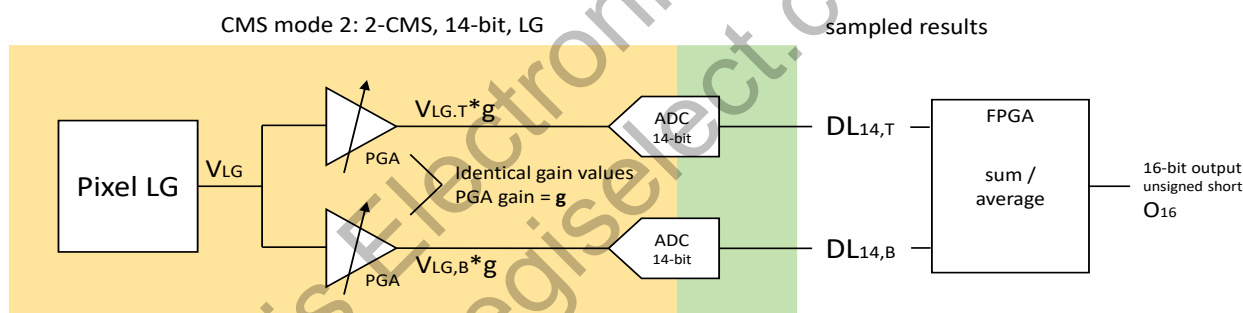

$V_{LG}$  : analog LG values from pixel

$V_{LG,T} * g$  : analog LG values amplified by PGA gain  $g$ , top gain channel

$V_{LG,B} * g$  : analog LG values amplified by PGA gain  $g$ , bottom gain channel

$DL_{14,T}$  : digital 14-bit LG values, top gain channel

$DL_{14,B}$  : digital 14-bit LG values, bottom gain channel

The FPGA adds both pictures.

The 16-bit output result is calculated as

$$O_{16} = (DL_{14,T} + DL_{14,B}) * 2$$

### 3.2.3. CMS mode 3: 2-CMS, 12-bit, HG

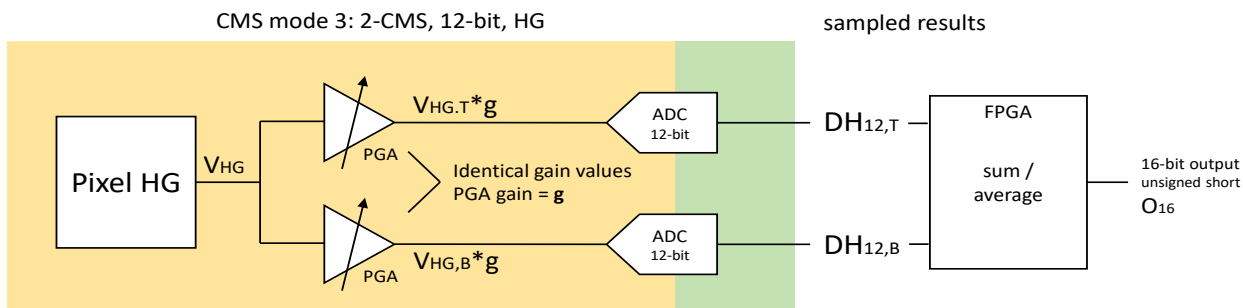

$V_{HG}$  : analog HG values from pixel

$V_{HG,T} * g$  : analog HG values amplified by PGA gain  $g$ , top gain channel

$V_{HG,B} * g$  : analog HG values amplified by PGA gain  $g$ , bottom gain channel

$DH_{12,T}$  : digital 12-bit HG values, top gain channel

$DH_{12,B}$  : digital 12-bit HG values, bottom gain channel

The FPGA adds both pictures.

The 16-bit output result is calculated as

$$O_{16} = (DH_{12,T} + DH_{12,B}) * 8$$

### 3.2.4. CMS mode 4: 2-CMS, 14-bit, HG

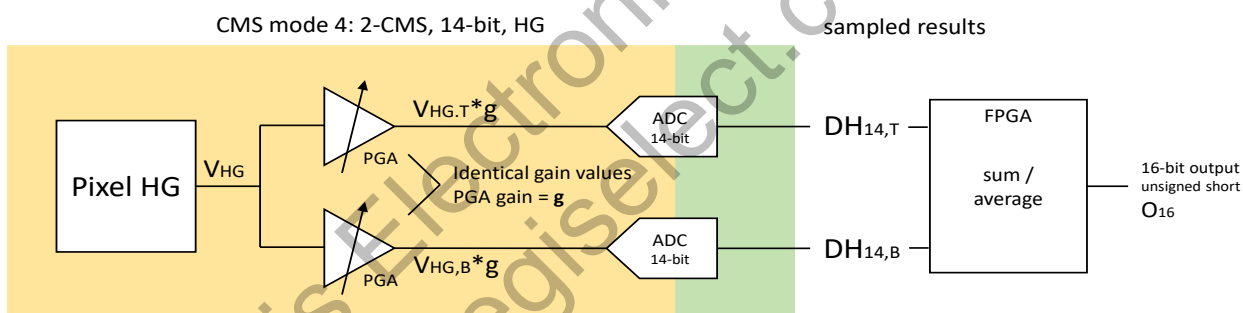

$V_{HG}$  : analog HG values from pixel

$V_{HG,T} * g$  : analog HG values amplified by PGA gain  $g$ , top gain channel

$V_{HG,B} * g$  : analog HG values amplified by PGA gain  $g$ , bottom gain channel

$DH_{14,T}$  : digital 14-bit HG values, top gain channel

$DH_{14,B}$  : digital 14-bit HG values, bottom gain channel

The FPGA adds both pictures.

The 16-bit output result is calculated as

$$O_{16} = (DH_{14,T} + DH_{14,B}) * 2$$

### 3.2.5. CMS mode 5: 4-CMS, 12-bit, LG

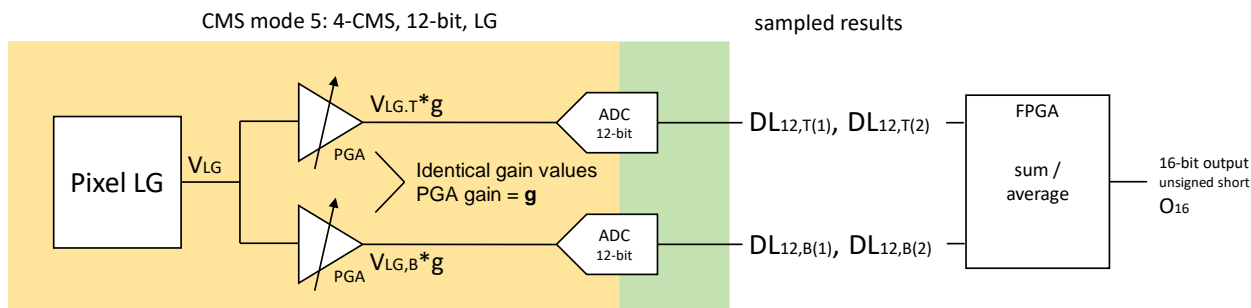

$V_{LG}$  : analog LG values from pixel

$V_{LG,T} * g$  : analog LG values amplified by PGA gain  $g$ , top gain channel

$V_{LG,B} * g$  : analog LG values amplified by PGA gain  $g$ , bottom gain channel

$DL_{12,T(1)}$  : digital 12-bit LG values, top gain channel, sampling 1

$DL_{12,T(2)}$  : digital 12-bit LG values, top gain channel, sampling 2

$DL_{12,B(1)}$  : digital 12-bit LG values, bottom gain channel, sampling 1

$DL_{12,B(2)}$  : digital 12-bit LG values, bottom gain channel, sampling 2

The FPGA adds all four pictures.

The 16-bit output result is calculated as

$$O_{16} = (DL_{12,T(1)} + DL_{12,T(2)} + DL_{12,B(1)} + DL_{12,B(2)}) * 4$$

### 3.2.6. CMS mode 6: 4-CMS, 14-bit, LG

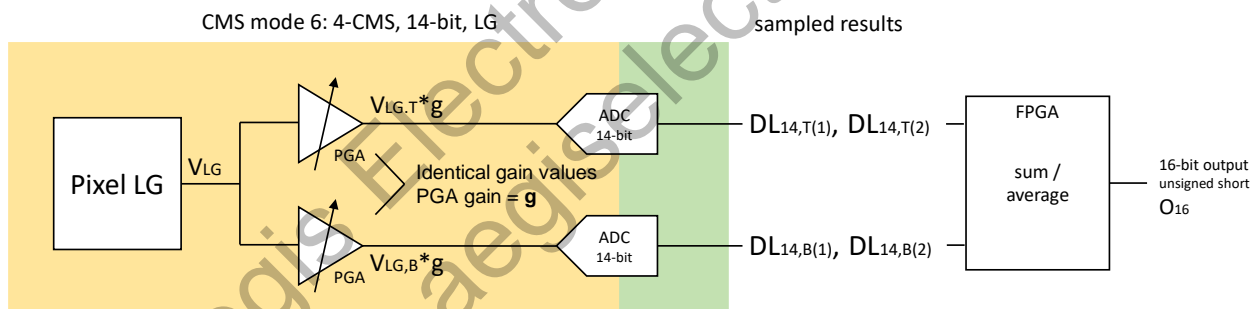

$V_{LG}$  : analog LG values from pixel

$V_{LG,T} * g$  : analog LG values amplified by PGA gain  $g$ , top gain channel

$V_{LG,B} * g$  : analog LG values amplified by PGA gain  $g$ , bottom gain channel

$DL_{14,T(1)}$  : digital 14-bit LG values, top gain channel, sampling 1

$DL_{14,T(2)}$  : digital 14-bit LG values, top gain channel, sampling 2

$DL_{14,B(1)}$  : digital 14-bit LG values, bottom gain channel, sampling 1

$DL_{14,B(2)}$  : digital 14-bit LG values, bottom gain channel, sampling 2

The FPGA adds all four pictures.

The 16-bit output result is calculated as

$$O_{16} = DL_{14,T(1)} + DL_{14,T(2)} + DL_{14,B(1)} + DL_{14,B(2)}$$

### 3.2.7. CMS mode 7: 4-CMS, 12-bit, HG

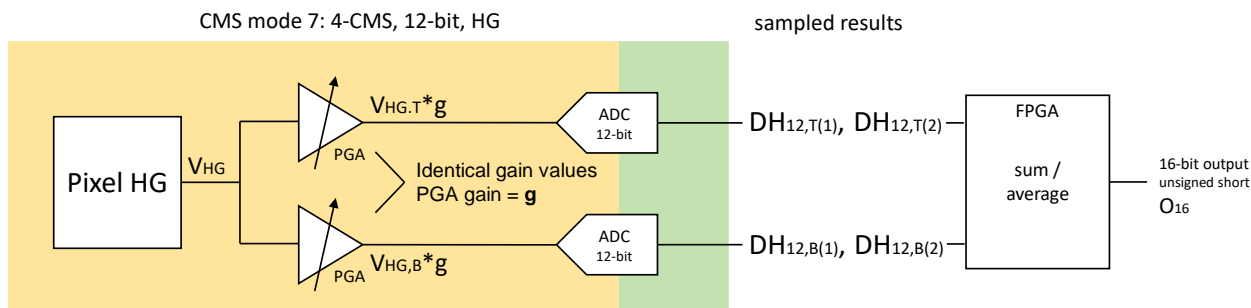

$V_{HG}$  : analog HG values from pixel

$V_{HG,T} * g$  : analog HG values amplified by PGA gain  $g$ , top gain channel

$V_{HG,B} * g$  : analog HG values amplified by PGA gain  $g$ , bottom gain channel

$DH_{12,T(1)}$  : digital 12-bit HG values, top gain channel, sampling 1

$DH_{12,T(2)}$  : digital 12-bit HG values, top gain channel, sampling 2

$DH_{12,B(1)}$  : digital 12-bit HG values, bottom gain channel, sampling 1

$DH_{12,B(2)}$  : digital 12-bit HG values, bottom gain channel, sampling 2

The FPGA adds all four pictures.

The 16-bit output result is calculated as

$$O_{16} = (DH_{12,T(1)} + DH_{12,T(2)} + DH_{12,B(1)} + DH_{12,B(2)}) * 4$$

### 3.2.8. CMS mode 8: 4-CMS, 14-bit, HG

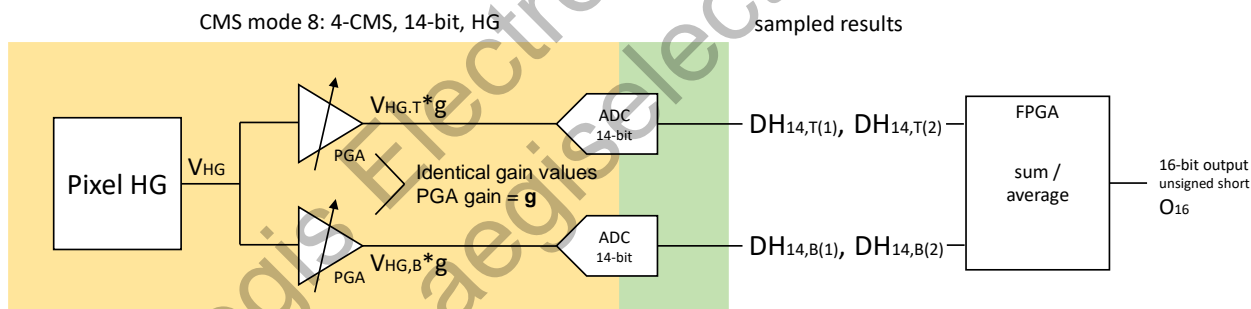

$V_{HG}$  : analog HG values from pixel

$V_{HG,T} * g$  : analog HG values amplified by PGA gain  $g$ , top gain channel

$V_{HG,B} * g$  : analog HG values amplified by PGA gain  $g$ , bottom gain channel

$DH_{14,T(1)}$  : digital 14-bit HG values, top gain channel, sampling 1

$DH_{14,T(2)}$  : digital 14-bit HG values, top gain channel, sampling 2

$DH_{14,B(1)}$  : digital 14-bit HG values, bottom gain channel, sampling 1

$DH_{14,B(2)}$  : digital 14-bit HG values, bottom gain channel, sampling 2

The FPGA adds all four pictures.

The 16-bit output result is calculated as

$$O_{16} = DH_{14,T(1)} + DH_{14,T(2)} + DH_{14,B(1)} + DH_{14,B(2)}$$

### 3.3. HDR modes

The HDR modes work significantly different than the STD and CMS modes.

The gain values of the two PGA-ADC readout channels are different.

XIMEA does not use the gain values described by GPixel in their sensor manuals but uses its own parameters to achieve optimized results.

The gain values cannot be influenced by the user through API settings.

XIMEA has implemented two additional HDR modes in addition to the two standard HDR modes (HDR and HDR 2-CMS).

#### 3.3.1. HDR modes using LG and HG data (Standard HDR modes described in the sensor specs)

In both modes HDR and HRS 2-CMS the LG and HG values from the pixel are read during one readout. The LG part is processed by the top gain channel, the HG part by the bottom gain channel.

To achieve that HG and LG values are available in one readout cycle, the readout is divided into two phases. The readout status of the pixel and the target (gain channels) is changed from phase 1 to phase 2.

For this the status of HDR is changed between phase 1 and phase 2:

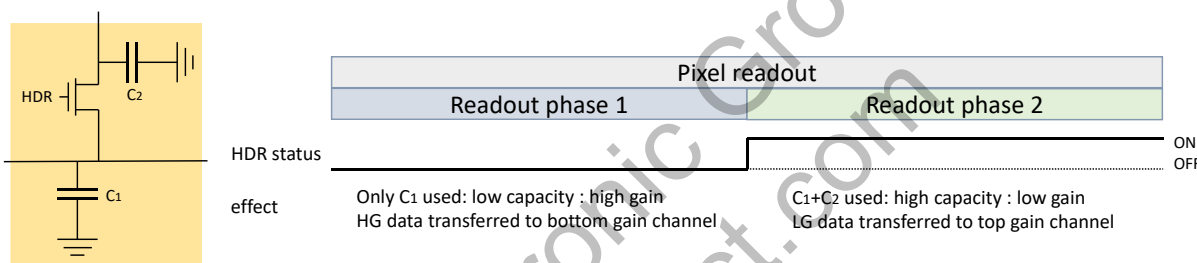

#### 3.3.2. 12-bit HDR mode, LG and HG

As described above, the HG value of the pixel is transmitted to the bottom and the LG value to the top gain channel:

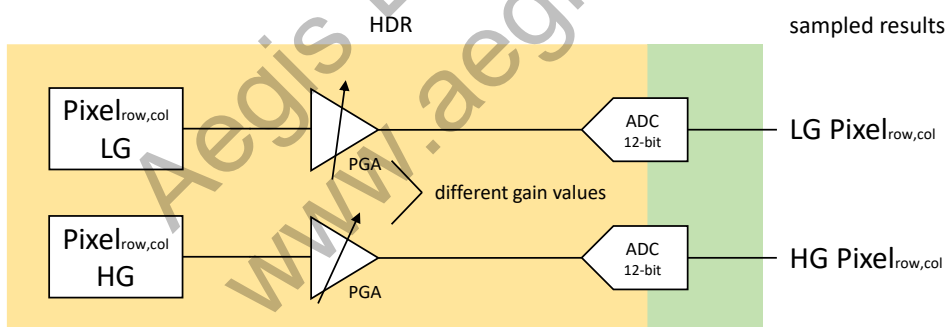

#### 3.3.3. 12-bit HDR 2-CMS mode, LG and HG

In HDR 2-CMS mode the pixel data is additionally sampled and delivered twice in a row on each gain channel. In total, the complete picture information is processed twice in this mode.

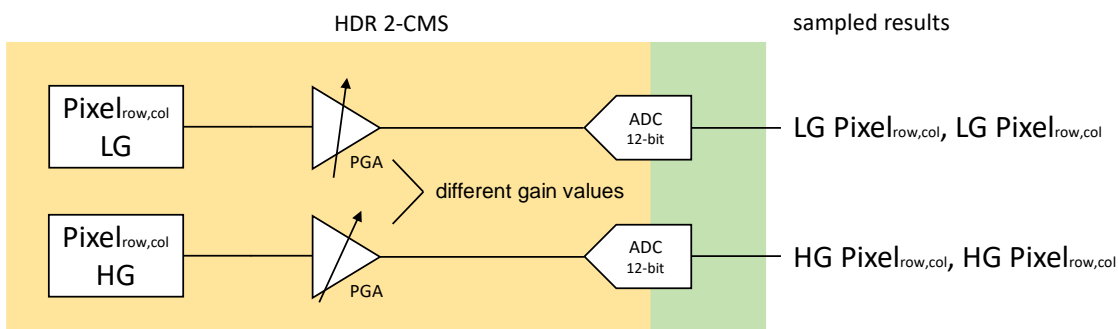

### 3.3.4. 12-bit HDR mode, LG or HG

The two additional HDR modes of the MX377 camera use different, fixed gain values on both gain channels, but read either only the LG or HG value from the sensor.

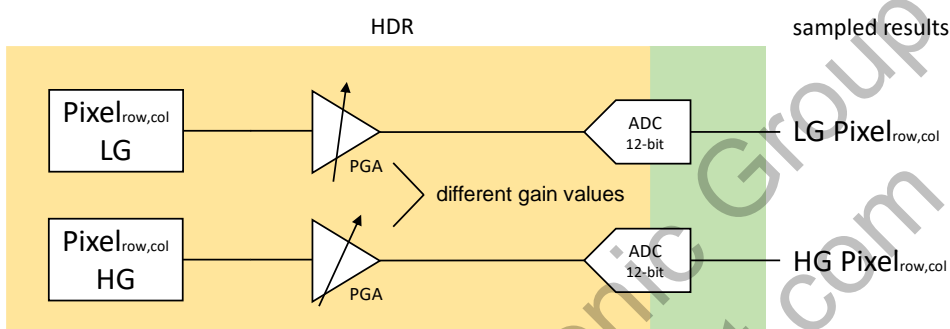

### 3.3.5. Modes

The following HDR modes are supported:

Samples per channel	ADC depth	HG/LG readout	MX377 mode
1	12	HG + LG	HDR mode 1: 2-12-HDR-HL
1	12	LG	HDR mode 2: 2-12-HDR-L
1	12	HG	HDR mode 3: 2-12-HDR-H
2-CMS	12	HG + LG	HDR mode 4: 4-12-CMS-HDR-HL
1	14	LG	HDR mode 5: 2-14-HDR-L
1	14	HG	HDR mode 6: 2-14-HDR-H

The image data is transferred within the camera once or twice (HDR-mode 4) to the FPGA, where they are summed (only in HDR mode 4) and merged with a XIMEA HDR algorithm.

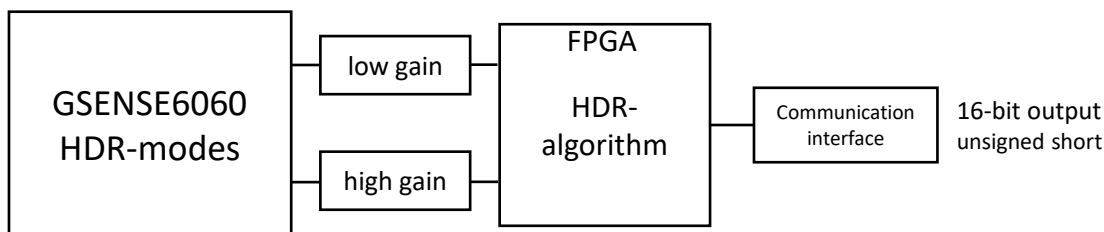

### 3.3.5.1. HDR mode 1: 12-bit, HG + LG

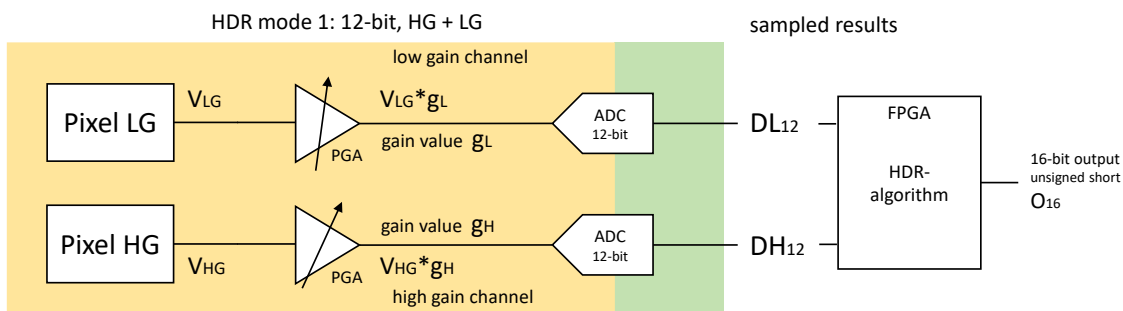

- VLG : analog LG values from pixel
- VHG : analog HG values from pixel
- gL : analog PGA gain of low gain channel
- gH : analog PGA gain of high gain channel
- VLG\*gL : analog LG values amplified by PGA gain gL, low gain channel
- VHG\*gH : analog HG values amplified by PGA gain gH, high gain channel
- DL12 : digital 12-bit LG values
- DH12 : digital 12-bit HG values

The FPGA merges the values to an HDR image.

The 16-bit output result is calculated as

$$O_{16} = (\text{unsigned short}) \left( \left( DL_{12} \frac{DH_{12}}{4095.0} + DH_{12} \left( 1 + \frac{DH_{12}}{4095.0} \right) \frac{g_L}{g_H} \right) * 16.0 \right)$$

### 3.3.5.2. HDR mode 2: 12-bit, LG

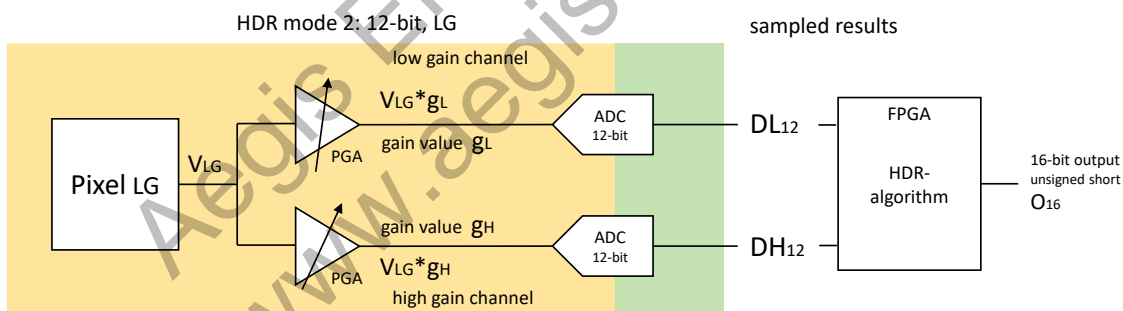

- VLG : analog LG values from pixel
- gL : analog PGA gain of low gain channel
- gH : analog PGA gain of high gain channel
- VLG\*gL : analog LG values amplified by PGA gain gL, low gain channel
- VLG\*gH : analog LG values amplified by PGA gain gH, high gain channel
- DL12 : digital 12-bit LG values processed by low gain channel
- DH12 : digital 12-bit LG values processed by high gain channel

The FPGA merges the values to an HDR image.

The 16-bit output result is calculated as

$$O_{16} = (\text{unsigned short}) \left( \left( DL_{12} \frac{DH_{12}}{4095.0} + DH_{12} \left( 1 - \frac{DH_{12}}{4095.0} \right) \frac{g_L}{g_H} \right) * 16.0 \right)$$

### 3.3.5.3. HDR mode 3: 12-bit, HG

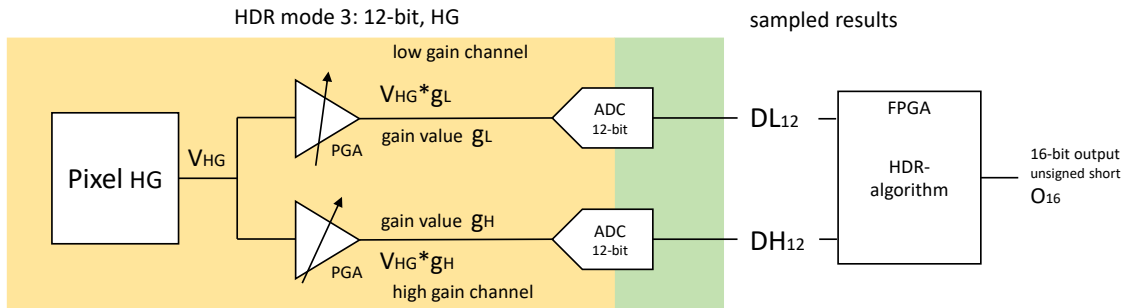

$V_{HG}$  : analog HG values from pixel

$g_L$  : analog PGA gain of low gain channel

$g_H$  : analog PGA gain of high gain channel

$V_{HG} * g_L$  : analog HG values amplified by PGA gain  $g_L$ , low gain channel

$V_{HG} * g_H$  : analog HG values amplified by PGA gain  $g_H$ , high gain channel

$DL_{12}$  : digital 12-bit HG values processed by low gain channel

$DH_{12}$  : digital 12-bit HG values processed by high gain channel

The FPGA merges the values to an HDR image.

The 16-bit output result is calculated as

$$O_{16} = (\text{unsigned short}) \left( \left( DL_{12} \frac{DH_{12}}{4095.0} + DH_{12} \left( 1 - \frac{DH_{12}}{4095.0} \right) \frac{g_L}{g_H} \right) * 16.0 \right)$$

Aegis Electronic Group  
www.aegiselect.com

### 3.3.5.4. HDR mode 4: 2-CMS, 12-bit, HG + LG

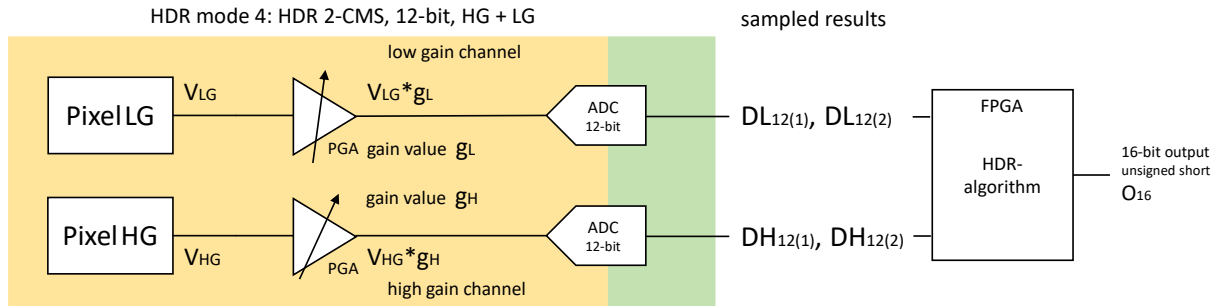

$V_{LG}$  : analog LG values from pixel

$V_{HG}$  : analog HG values from pixel

$g_L$  : analog PGA gain of low gain channel

$g_H$  : analog PGA gain of high gain channel

$V_{LG} * g_L$  : analog LG values amplified by PGA gain  $g_L$ , low gain channel

$V_{HG} * g_H$  : analog HG values amplified by PGA gain  $g_H$ , high gain channel

$DL_{12(1)}$  : digital 12-bit LG values, low gain channel, sampling 1

$DL_{12(2)}$  : digital 12-bit LG values, low gain channel, sampling 2

$DH_{12(1)}$  : digital 12-bit HG values, high gain channel, sampling 1

$DH_{12(2)}$  : digital 12-bit HG values, high gain channel, sampling 2

The FPGA merges the values to an HDR image.

The 16-bit output result is calculated as

$$O_{16} = (\text{unsigned short}) \left( \left( DL_{12} \frac{DH_{12}}{8191.0} + DH_{12} \left( 1 - \frac{DH_{12}}{8191.0} \right) \frac{g_L}{g_H} \right) * 8.0 \right)$$

$$DL_{12} = DL_{12(1)} + DL_{12(2)}$$

$$DH_{12} = H_{12(1)} + DH_{12(2)}$$

### 3.3.5.5. HDR mode 5: 14-bit, LG

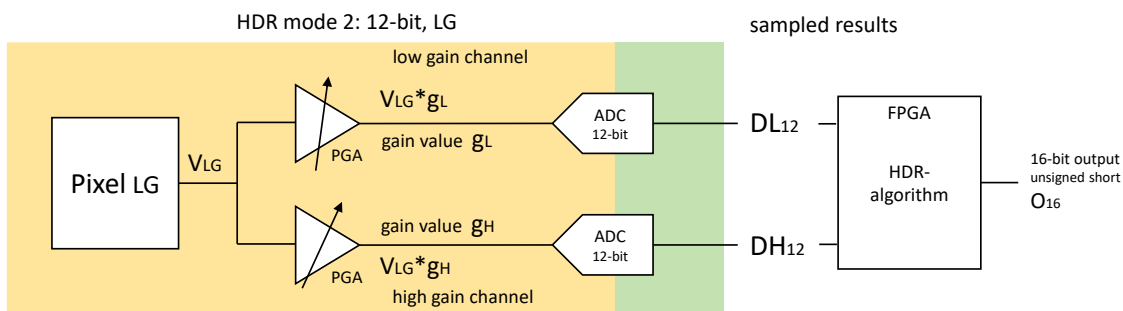

- $V_{LG}$  : analog LG values from pixel
- $g_L$  : analog PGA gain of low gain channel
- $g_H$  : analog PGA gain of high gain channel
- $V_{LG} * g_L$  : analog LG values amplified by PGA gain  $g_L$ , low gain channel
- $V_{LG} * g_H$  : analog LG values amplified by PGA gain  $g_H$ , high gain channel
- $DL_{14}$  : digital 14-bit LG values processed by low gain channel
- $DH_{14}$  : digital 14-bit LG values processed by high gain channel

The FPGA merges the values to an HDR image.

The 16-bit output result is calculated as

$$O_{16} = (\text{unsigned short}) \left( \left( DL_{14} \frac{DH_{14}}{16383.0} + DH_{12} \left( 1 - \frac{DH_{14}}{16383.0} \right) \frac{g_L}{g_H} \right) * 4.0 \right)$$

### 3.3.5.6. HDR mode 6: 14-bit, HG

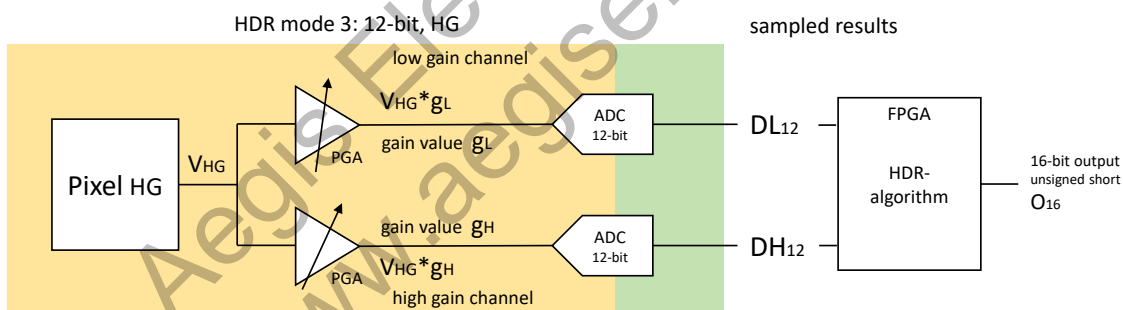

- $V_{HG}$  : analog HG values from pixel
- $g_L$  : analog PGA gain of low gain channel
- $g_H$  : analog PGA gain of high gain channel
- $V_{HG} * g_L$  : analog HG values amplified by PGA gain  $g_L$ , low gain channel
- $V_{HG} * g_H$  : analog HG values amplified by PGA gain  $g_H$ , high gain channel
- $DL_{14}$  : digital 14-bit HG values processed by low gain channel
- $DH_{14}$  : digital 14-bit HG values processed by high gain channel

The FPGA merges the values to an HDR image.

The 16-bit output result is calculated as

$$O_{16} = (\text{unsigned short}) \left( \left( DL_{12} \frac{DH_{12}}{4095.0} + DH_{12} \left( 1 - \frac{DH_{12}}{4095.0} \right) \frac{g_L}{g_H} \right) * 16.0 \right)$$

## 4. Camera settings

### 4.1. mode settings - API

The different camera modes are controlled by different settings in the API:

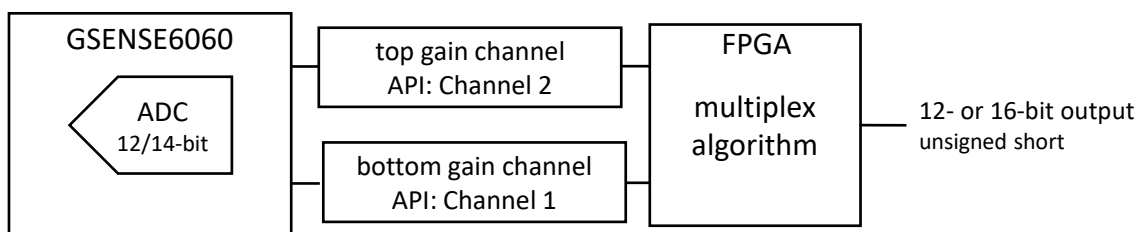

Mode	data values per pixel	FPGA algorithm (channel multiplexer)	Sensor readout		
			Channel timing		ADC width
			Bottom / CH1	Top / CH2	
12-STD-L	1	sequencer	LG	LG	12
12-STD-H	1	sequencer	HG	HG	12
14-STD-L	1	sequencer	LG	LG	14
14-STD-H	1	sequencer	HG	HG	14
2-12-CMS-S-L	2	sum	LG	LG	12
2-12-CMS-S-H	2	sum	HG	HG	12
2-14-CMS-S-L	2	sum	LG	LG	14
2-14-CMS-S-H	2	sum	HG	HG	14
4-12-CMS-S-L	4	sum	LG	LG	12
4-12-CMS-S-H	4	sum	HG	HG	12
4-14-CMS-S-L	4	sum	LG	LG	14
4-14-CMS-S-H	4	sum	HG	HG	14
2-12-HDR-HL	2	HDR	HG	LG	(fix) 12
2-12-HDR-L	2	HDR	LG	LG	(fix) 12
2-12-HDR-H	2	HDR	HG	HG	(fix) 12
4-12-CMS-HDR-HL	4	HDR	HG	LG	(fix) 12
2-14-HDR-L	2	HDR	LG	LG	(fix) 14
2-14-HDR-H	2	HDR	HG	HG	(fix) 14

The parameters must be set in application programs in a defined order:

- 1: Sensor: data values per pixel
- 2: FPGA: channel multiplexer algorithm
- 3: Sensor: channel 1 timing (LG or HG)
- 4: Sensor: channel 2 timing (LG or HG)
- 5: (not in HDR modes): sensor bit depth (ADC width)

Please have a look at [https://www.ximea.com/support/wiki/apis/XiAPI\\_Manual#XI\\_PRM\\_DP\\_UNIT\\_SELECTOR-or-dp\\_unit\\_selector](https://www.ximea.com/support/wiki/apis/XiAPI_Manual#XI_PRM_DP_UNIT_SELECTOR-or-dp_unit_selector) for additional info.

The parameters listed in the table above have the following API representations:

### Sensor: data values per pixel

Sensor PIXEL\_SEQUENCER

data values per pixel	Parameter setting (enum)	Related numeric value
1	XI_DP_PARAM_VALUE_PIXSEQ_ONE_VALUE	5
2	XI_DP_PARAM_VALUE_PIXSEQ_TWO_VALUES	6
4	XI_DP_PARAM_VALUE_PIXSEQ_FOUR_VALUES	11

```
xiSetParamInt(handle, XI_PRM_DP_UNIT_SELECTOR, XI_DP_UNIT_SENSOR);
xiSetParamInt(handle, XI_PRM_DP_PROC_SELECTOR, XI_DP_PROC_PIXEL_SEQUENCER);
xiSetParamInt(handle, XI_PRM_DP_PARAM_SELECTOR, XI_DP_PARAM_PIXSEQ_SELECTOR);
xiSetParamFloat(handle, XI_PRM_DP_PARAM_VALUE, value); // from table above
```

### FPGA: channel multiplexer algorithm

FPGA CHANNEL\_MUXER

FPGA algorithm	Parameter setting (enum)	Related numeric value
sequencer	XI_DP_PARAM_VALUE_CHMUX_CHANNEL_1_2	2
sum	XI_DP_PARAM_VALUE_CHMUX_CMS	4
HDR	XI_DP_PARAM_VALUE_CHMUX_MERGED	3

```
xiSetParamInt(handle, XI_PRM_DP_UNIT_SELECTOR, XI_DP_UNIT_FPGA);
xiSetParamInt(handle, XI_PRM_DP_PROC_SELECTOR, XI_DP_PROC_CHANNEL_MUXER);
xiSetParamInt(handle, XI_PRM_DP_PARAM_SELECTOR, XI_DP_PARAM_CHMUX_CHANNEL_SELECTOR);
xiSetParamFloat(handle, XI_PRM_DP_PARAM_VALUE, value); // from table above
```

### Sensor: channel 1 timing (LG or HG)

Sensor CHANNEL\_TIMING channel 1

Timing Channel 1	Parameter setting (enum)	Related numeric value
LG	XI_DP_PARAM_VALUE_CHTIM_LG	8
HL	XI_DP_PARAM_VALUE_CHTIM_HG	7

```
xiSetParamInt(handle, XI_PRM_DP_UNIT_SELECTOR, XI_DP_UNIT_SENSOR);
xiSetParamInt(handle, XI_PRM_DP_PROC_SELECTOR, XI_DP_PROC_CHANNEL_1);
xiSetParamInt(handle, XI_PRM_DP_PARAM_SELECTOR, XI_DP_PARAM_CHANNEL_TIMING);
xiSetParamFloat(handle, XI_PRM_DP_PARAM_VALUE, value); // from table above
```

### Sensor: channel 2 timing (LG or HG)

Sensor CHANNEL\_TIMING channel 2

Timing Channel 1	Parameter setting (enum)	Related numeric value
LG	XI_DP_PARAM_VALUE_CHTIM_LG	8
HL	XI_DP_PARAM_VALUE_CHTIM_HG	7

```
xiSetParamInt(handle, XI_PRM_DP_UNIT_SELECTOR, XI_DP_UNIT_SENSOR);
xiSetParamInt(handle, XI_PRM_DP_PROC_SELECTOR, XI_DP_PROC_CHANNEL_2);
xiSetParamInt(handle, XI_PRM_DP_PARAM_SELECTOR, XI_DP_PARAM_CHANNEL_TIMING);
xiSetParamFloat(handle, XI_PRM_DP_PARAM_VALUE, value); // from table above
```

#### sensor bit depth (ADC width - not in HDR modes)

12-bit:

```
xiSetParamInt(handle, XI_PRM_SENSOR_DATA_BIT_DEPTH, XI_BPP_12);
```

14-bit:

```
xiSetParamInt(handle, XI_PRM_SENSOR_DATA_BIT_DEPTH, XI_BPP_14);
```

Please have a look at [https://www.ximea.com/support/wiki/apis/XiAPI\\_Manual#XI\\_PRM\\_SENSOR\\_DATA\\_BIT\\_DEPTH-or-sensor\\_bit\\_depth](https://www.ximea.com/support/wiki/apis/XiAPI_Manual#XI_PRM_SENSOR_DATA_BIT_DEPTH-or-sensor_bit_depth) for additional info.

## 4.2. mode settings - factory presets (API)

To simplify the use of the camera modes in the API, presets can be used instead of setting all individual parameters (as above).

Mode	Parameter setting (enum)	Related numeric value
12-STD-L	XI_US_12_STD_L	10
12-STD-H	XI_US_12_STD_H	11
14-STD-L	XI_US_14_STD_L	12
14-STD-H	XI_US_14_STD_H	13
2-12-CMS-S-L	XI_US_2_12_CMS_L	14
2-12-CMS-S-H	XI_US_2_12_CMS_H	15
2-14-CMS-S-L	XI_US_2_14_CMS_L	16
2-14-CMS-S-H	XI_US_2_14_CMS_H	17
4-12-CMS-S-L	XI_US_4_12_CMS_L	18
4-12-CMS-S-H	XI_US_4_12_CMS_H	19
4-14-CMS-S-L	XI_US_4_14_CMS_L	20
4-14-CMS-S-H	XI_US_4_14_CMS_H	21
2-12-HDR-HL	XI_US_2_12_HDR_HL	22
2-12-HDR-L	XI_US_2_12_HDR_L	23
2-12-HDR-H	XI_US_2_12_HDR_H	24
4-12-CMS-HDR-HL	XI_US_4_12_CMS_HDR_HL	25
2-14-HDR-L	XI_US_2_14_HDR_L	26
2-14-HDR-H	XI_US_2_14_HDR_H	27

The desired mode can be used as preset by selecting and setting:

```
xiSetParamInt(handle, XI_PRM_USER_SET_SELECTOR, value); // from table above
xiSetParamInt(handle, XI_PRM_USER_SET_LOAD, XI_ON);
```

Please have a look at [https://www.ximea.com/support/wiki/apis/XiAPI\\_Manual#XI\\_PRM\\_USER\\_SET\\_SELECTOR-or-user\\_set\\_selector](https://www.ximea.com/support/wiki/apis/XiAPI_Manual#XI_PRM_USER_SET_SELECTOR-or-user_set_selector) for additional info.

### 4.3. mode settings - xiCamTool

In the extended viewer xiCamTool you can directly access the camera modes with the presets.

The UserSetControl is part of the "Camera Settings" panel, which is displayed on the right side by default.

When a User Set is loaded, all parameters specified in it are always set. For example, the gain value is also reset. This also applies if the already selected mode is set again.

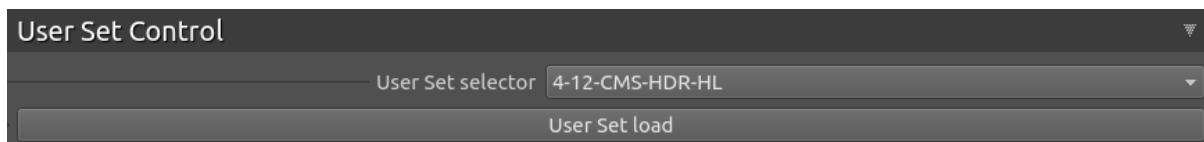

### 4.4. Gain settings (API)

The API does not support digital gain setting functions for the MX377.

The analog gain can be set:

Mode	Analog gain range [dB]
Low gain, STD- and CMS-modes	0.0 – 10.5, increment 0.1
High gain, STD- and CMS-modes	0.0 – 21.4, increment 0.1 (Note 1)
HDR-modes	gain values are fixed and cannot be changed or read out

**Note 1:** GPIXEL does not recommend setting gain higher than 12.4 dB in 12bit high gain modes due to degrading image quality.

Analog gain setting (e.g. to 13.0):

```
xiSetParamInt(xiH, XI_PRM_GAIN_SELECTOR, XI_GAIN_SELECTOR_ANALOG_ALL);
xiSetParamFloat(xiH, XI_PRM_GAIN, (float) 13.0);
```

Please have a look at [https://www.ximea.com/support/wiki/apis/XiAPI\\_Manual#XI\\_PRM\\_GAIN\\_SELECTOR-or-gain\\_selector](https://www.ximea.com/support/wiki/apis/XiAPI_Manual#XI_PRM_GAIN_SELECTOR-or-gain_selector) for additional info.

### 4.5. Sensor cooling

The dark-current value of the sensors depends on the sensor-die-temperature. For longer exposure times it is therefore advisable to actively cool the sensor.

We offer alternatively an active fan cooling and a connection for a water cooling. In normal office/laboratory environments the sensors can be cooled down to -10°C (fan) or -30°C (water cooling).

#### 4.5.1. Sensor cooling – API

The XIMEA API offers a convenient way to set the sensor temperature measured on the sensor board. The temperature is then automatically reached and stabilized, if possible. A too low set temperature will cause the cooling system to run continuously at full power without reaching the set value.

The sensor temperature is set by the following commands (0°C for instance):

```
xiSetParamFloat(handle, XI_PRM_TARGET_TEMP, (float) 0.0); // or 0.F
xiSetParamInt(handle, XI_PRM_COOLING, XI_TEMP_CTRL_MODE_AUTO);
```

Four different temperature values can be read out with the MX377:

```

XI_TEMP_IMAGE_SENSOR_DIE_RAW
XI_TEMP_SENSOR_BOARD
XI_TEMP_FRONT_HOUSING
XI_TEMP_REAR_HOUSING

```

They can be read out (here using the example XI\_TEMP\_SENSOR\_BOARD) as follows:

```

xiSetParamInt(handle, XI_PRM_TEMP_SELECTOR, XI_TEMP_SENSOR_BOARD);
xiGetParamFloat(handle, XI_PRM_TARGET_TEMP, &target_temp);

```

Please have a look at [https://www.ximea.com/support/wiki/apis/XiAPI\\_Manual#XI\\_PRM\\_IS\\_COOLED-or-iscooled](https://www.ximea.com/support/wiki/apis/XiAPI_Manual#XI_PRM_IS_COOLED-or-iscooled) for additional info.

### 4.5.2. Sensor cooling – xiCamTool

The Temperature control is part of the "Camera Settings" panel, which is displayed on the right side by default. The cooling and the desired temperature can be activated or set:

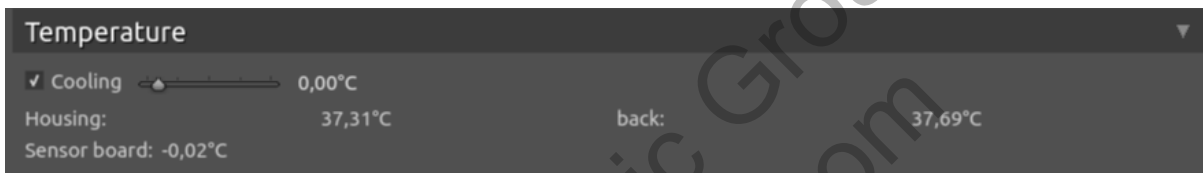

Also, a temperature graph can be displayed:

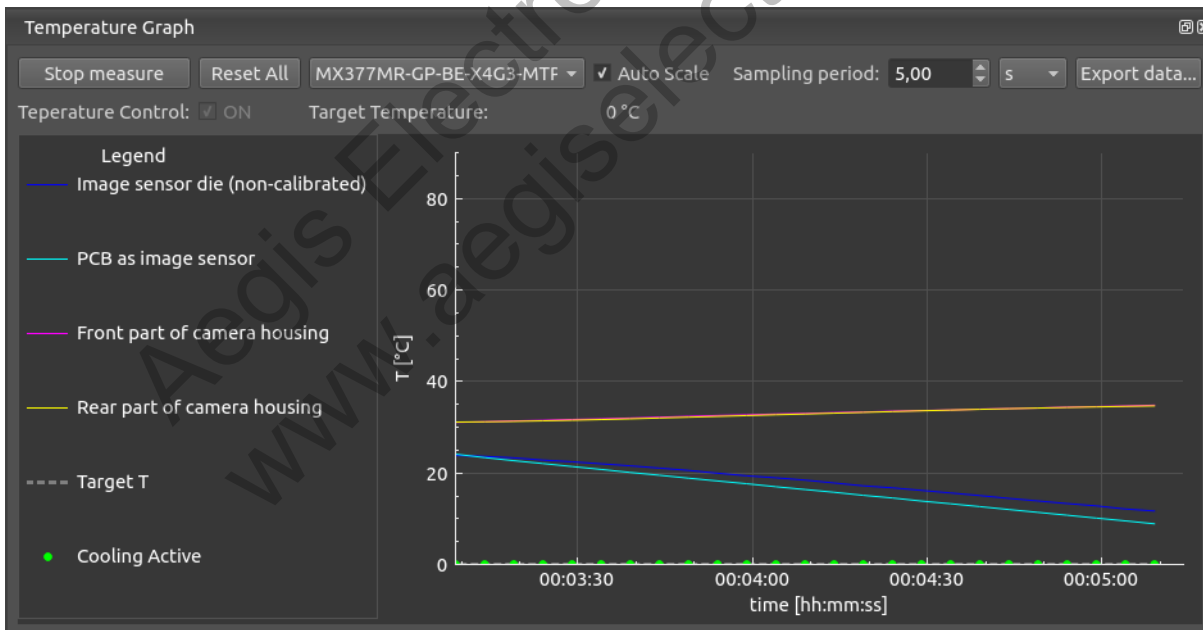

This graph can be activated using the setting:

Tools \ Temperature Graph

## 5. Measurements

### 5.1. Frame rates

The frame rate is higher in the standard modes because two image rows are read in parallel.

Preliminary frame rate table (FSI and BSI):

Mode	Decimation (horizontal x vertical)				Output
	1x1	1x2	1x3	1x4	
	Framerate(fps)				
12-STD-L	48,2	48,2	72,1	95,8	12-bit
12-STD-H	48,2	48,2	72,1	95,8	12-bit
14-STD-L	13,1	13,1	19,7	26,1	16-bit
14-STD-H	13,1	13,1	19,7	26,1	16-bit
2-12-CMS-L	24,2	48,2	72,1	95,8	16-bit
2-12-CMS-H	24,2	48,2	72,1	95,8	16-bit
2-14-CMS-L	6,6	13,1	19,7	26,1	16-bit
2-14-CMS-H	6,6	13,1	19,7	26,1	16-bit
4-12-CMS-L	7,2	14,5	21,6	28,7	16-bit
4-12-CMS-H	7,2	14,5	21,6	28,7	16-bit
4-14-CMS-L	2,6	5,2	7,7	10,3	16-bit
4-14-CMS-H	2,6	5,2	7,7	10,3	16-bit
2-12-HDR-HL	16,1	32,1	48,0	63,9	16-bit
2-12-HDR-L	24,2	48,2	72,1	95,8	16-bit
2-12-HDR-H	24,2	48,2	72,1	95,8	16-bit
4-12-CMS-HDR-HL	6,9	13,8	20,6	27,4	16-bit

### 5.2. Rolling shutter - Sensor readout time

Read out the entire image at full resolution and maximum PCIe bandwidth / frame rate:

Mode	Readout time [ms]
12-STD-L	20.758
12-STD-H	
14-STD-L	76.113
14-STD-H	
2-12-CMS-L	41.402
2-12-CMS-H	
2-14-CMS-L	151.807
2-14-CMS-H	
4-12-CMS-L	138.006
4-12-CMS-H	
4-14-CMS-L	386.418
4-14-CMS-H	
2-12-HDR-HL	62.103
2-12-HDR-L	41.402
2-12-HDR-H	
4-12-CMS-HDR-HL	144.907

### 5.3. FWC / total noise (preliminary measurements)

Measurements at +10°C

Mode	Gain=0 exp=20ms			Gain=24db exp=2ms			Gain=32db exp = 1 ms		
	FWC [ke]	RMS [e]	Median [e]	FWC [ke]	RMS [e]	Median [e]	FWC [ke]	RMS [e]	Median [e]
12-STD-L	144,66	32,88	29,58	10,01	4,34	3,82			
14-STD-L	140,00	27,13	24,35	9,14	4,25	3,38	3,98	3,65	2,90
2-12-CMS-L	142,60	24,23	22,19	9,69	4,17	3,43			
2-14-CMS-L	137,96	20,29	18,31	9,21	3,87	2,82	4,08	3,93	2,81
4-12-CMS-L	135,21	15,68	15,06	9,14	3,16	2,43			
4-14-CMS-L	138,84	12,91	11,98	9,37	3,22	2,36	4,18	3,27	2,12
2-12-HDR-HL	138,47	4,76	4,01						
2-12-HDR-L	140,02	14,63	13,43						
2-12-HDR-H	43,76	5,00	4,14						
4-12-CMS-HDR-HL	136,36	4,27	3,54						

Measurements at 0°C

Mode	analog gain [dB]	median dark noise [e-]	conversion gain [e-/DN]	saturation capacity [ke-]	dynamic range [dB]	max SNR [dB]	dark current from mean [e-]	DSNU [e-]
12_STD_L	0	28,52	26,95	101,22	71,00	50,33	1,20	13,17
12_STD_H	0	6,97	6,72	25,99	71,43	44,42	1,56	4,93
	12,4	2,75	1,94	7,60	68,84	38,78	1,53	7,73
14_STD_L	0	22,69	6,86	108,40	73,58	50,63	1,59	4,21
14_STD_H	0	5,73	1,71	26,69	73,36	44,44	2,37	1,31
	21,4	2,47	0,20	2,96	61,59	34,72	2,05	1,72
2_12_CMS_S_L	0	20,01	12,38	96,67	73,68	50,14	2,29	9,75
2_12_CMS_S_H	0	5,06	3,13	24,32	73,64	44,04	2,22	2,74
	12,4	2,36	0,91	7,09	69,56	38,45	1,43	2,73
2_14_CMS_S_L	0	16,94	3,52	108,77	76,15	50,80	2,76	2,19
2_14_CMS_S_H (FAST)	0	4,35	0,88	27,66	76,07	44,64	2,88	0,78
	21,4	2,30	0,10	3,18	62,80	35,14	2,83	0,86
	21,4	2,17	0,11	3,47	64,07	35,39	2,85	0,75
4_12_CMS_S_L	0	13,35	3,31	101,20	77,59	50,49	3,20	3,07
4_12_CMS_S_H	0	3,52	0,84	25,79	77,30	44,36	2,79	1,16
	12,4	2,09	0,24	7,50	71,10	38,71	3,01	1,42
4_14_CMS_S_L	0	11,18	1,70	106,01	79,54	50,62	5,36	1,85
4_14_CMS_S_H	0	2,98	0,43	26,68	79,05	44,46	4,48	0,71
	21,4	1,99	0,05	3,03	63,64	34,82	5,47	0,81
2_12_HDR_HL	-	3,57	1,69	97,53	88,74	50,32	3,22	2,19
2_12_HDR_L	-	12,14	1,59	91,56	77,55	50,26	2,84	13,28
2_12_HDR_H	-	3,25	0,35	21,95	76,59	43,93	2,69	2,84
4_12_CMS_HDR_HL	-	2,95	1,72	97,60	90,39	50,26	2,84	5,66
2_14_HDR_L	-	8,49	3,90	113,24	82,51	50,27	2,98	1,66
2_14_HDR_H	-	2,45	1,10	31,96	82,31	45,39	3,06	0,72

## 5.4. Power consumption / housing temperature (preliminary measurements)

Please note: All measured values listed here were measured with individual cameras. The values are not statistically secured. Information on mean values, lower and upper limits is therefore missing. All values are for information only.

### 5.4.1. Air cooled camera

Measurements at ambient temperature = 24°C, 20V power supply

Readout mode: 12-STD-L

t<sub>H</sub> : temperature housing [°C]

T<sub>exp</sub> : exposure time [ms]

W : power consumption [W]

Sens-Temp	25°C		10°C		0°C		-5°C		-10°C		-20°C	
	t <sub>H</sub>	W	t <sub>H</sub>	W	t <sub>H</sub>	W	t <sub>H</sub>	W	t <sub>H</sub>	W	t <sub>H</sub>	W
20	31,63	15,30	33,44	22,40	36,63	33,80	37,80	41,00				
5000	29,00	5,60	30,56	8,80	31,31	14,00	32,44	18,30	34,19	24,80	43,81	53,00

### 5.4.2. Liquid cooled camera

Measurements with water temperature = 23°C, 20V power supply

Readout mode: 12-STD-L

t<sub>H</sub>: temperature housing [°C]

T<sub>exp</sub>: exposure time [ms]

W: power consumption [W]

Sens-Temp	25°C		10°C		0°C		-10°C		-20°C		-30°C	
	t <sub>H</sub>	W	t <sub>H</sub>	W	t <sub>H</sub>	W	t <sub>H</sub>	W	t <sub>H</sub>	W	t <sub>H</sub>	W
20	21,80	14,00	22,10	16,60	22,44	21,60	24,44	29,90	27,25	48,20		
5000	20,70	5,60	20,76	6,30	20,81	8,70	21,75	13,70	22,38	22,40	24,31	38,60

## 5.5. Dark current

Measurements with a liquid cooled FSI camera, mode 4-14-CMS-L, Gain=32dB, FWC=4.44ke

Dc: dark current [e-/px/s]

Sens-Temp	20°C	10°C	0°C	-10°C	-20°C	-30°C
Dc	9,98	1,71	0,47	0,11	0,034	0,011

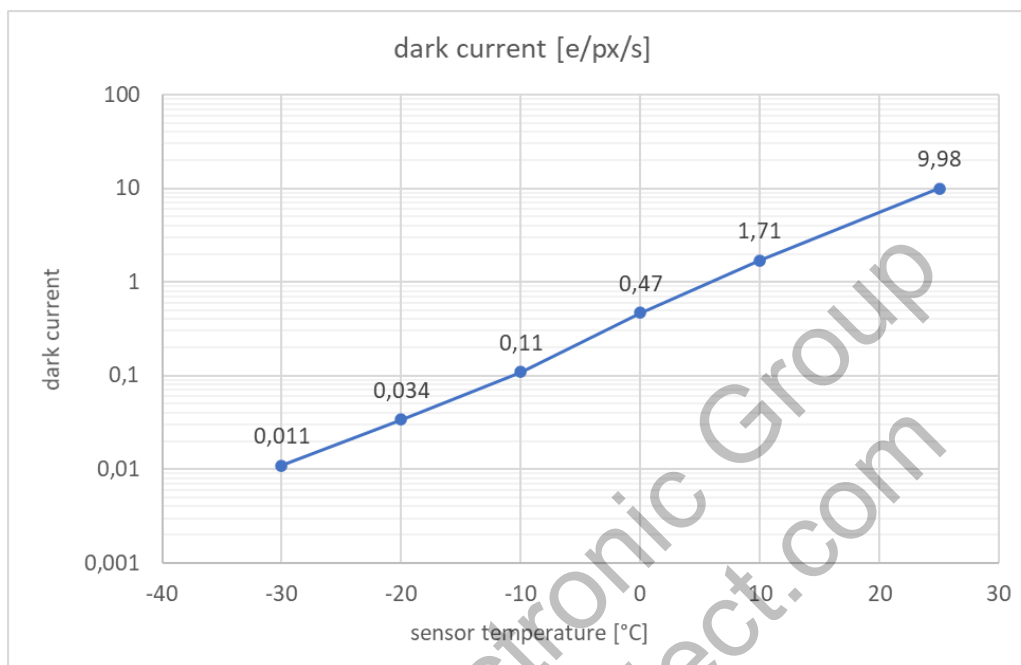

Graph for a BSI camera

## 5.6. Total noise, spatial distribution

The values of one MX377 camera, BSI, sensor grade 1 are shown as an example. Such measurements (especially sensor defects) depend on the sensor.

The total noise of each pixel was measured from 100 samples (frames). This image was then reduced by breaking it up into 16x16 pixels tiles and a maximum of each tile was used in the down sampled image.

Readout mode: 2-12-CMS-H

Exposure time: 100ms

Analog gain: 21.4 dB

Sensor temperature: -5 °C

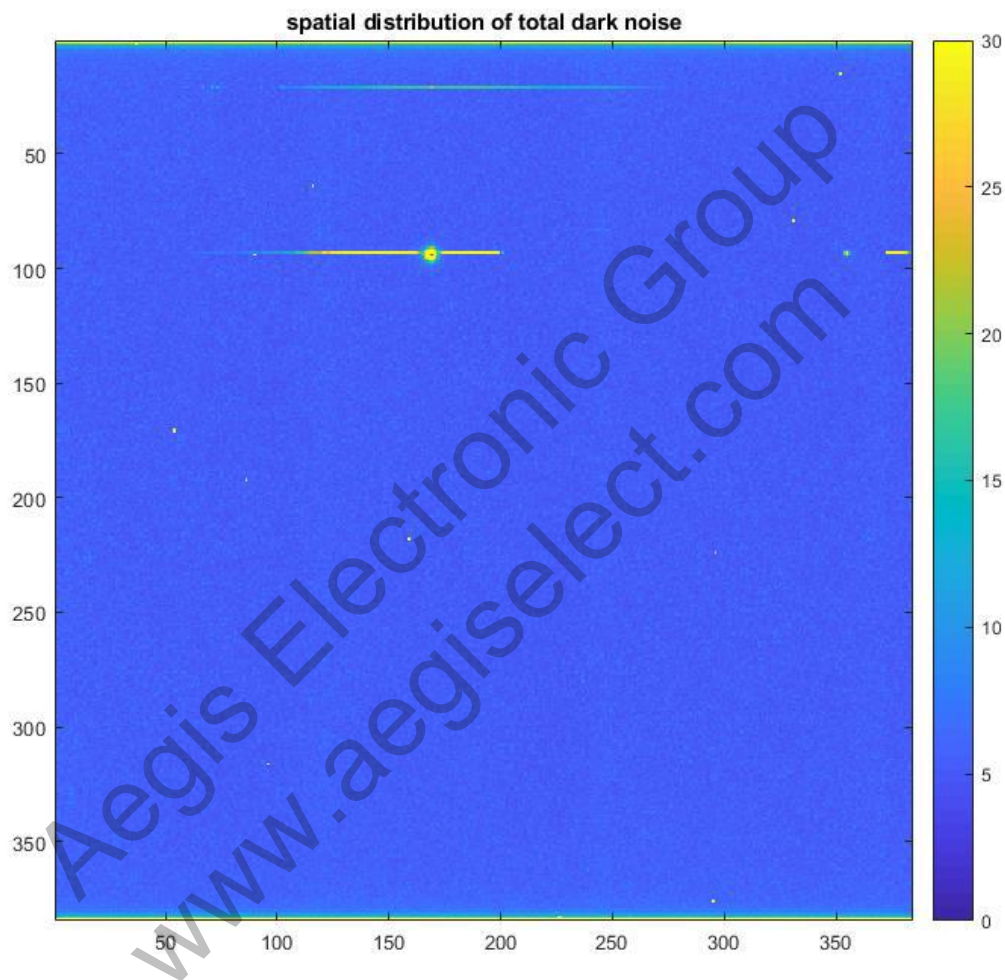

## 5.7. Sensor flatness

The sensors have an aluminum nitride package that has high thermal conductivity and high flatness and form stability at room temperature and deep cooling.

The sensors are relatively large and cannot be absolutely flat.

To get an impression of the flatness of the sensors, the height profile of several (BSI) sensors was measured with a laser scanning confocal microscope at room temperature.

For this purpose, 9 points on the sensor surface were measured:

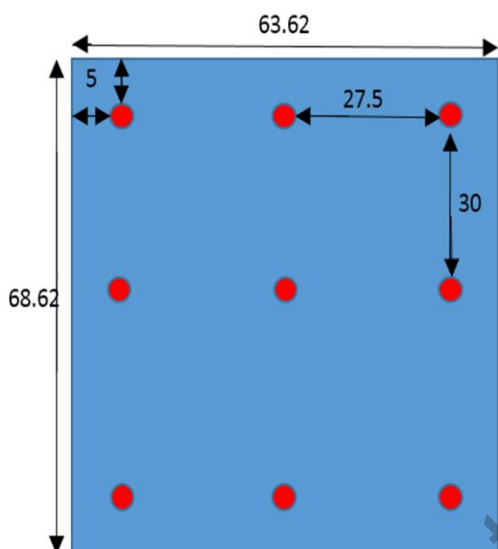

The differences between the highest and lowest points were generally between 50 and 58  $\mu\text{m}$  (minimum 30 $\mu\text{m}$ , maximum 60 $\mu\text{m}$ ).

Compared to a mean value, the heights vary by up to 30 $\mu\text{m}$ .

These values are for information only and are not specifications or defined properties.

## 6. MX377 housing

### 6.1. Front flange options

The camera MX377 consists of 4 parts in standard delivery condition (drawing with liquid cooler):

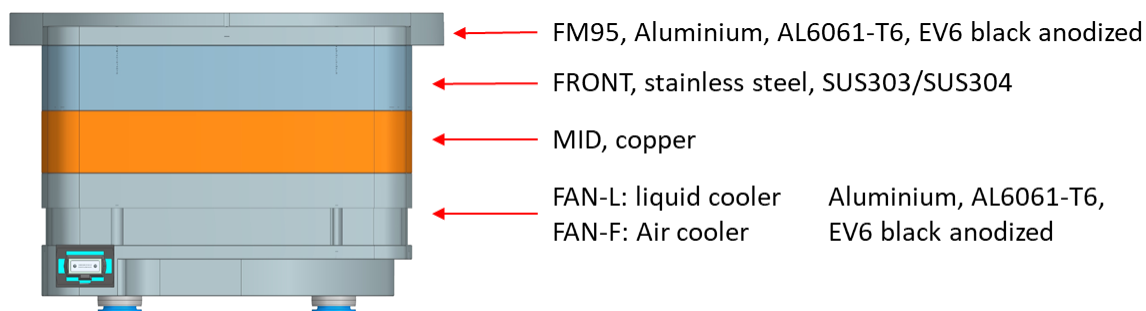

The assembly with the M95 lens thread is screwed to the front of the camera by 4 M3 screws and can be easily removed. Take care not to scratch the camera filter glass.

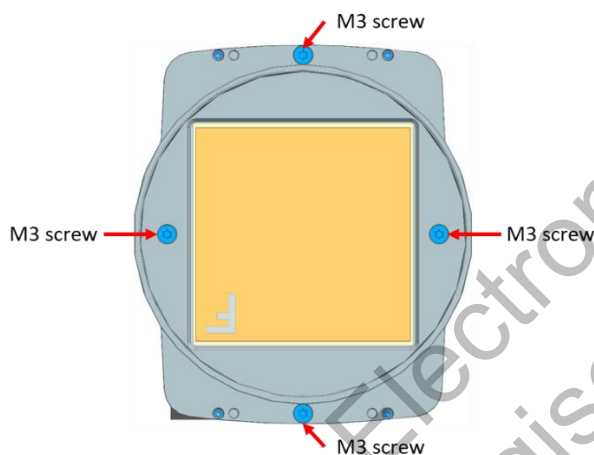

12 small countersunk screws secure the connection between the two parts FRONT and MID. These screws are countersunk in M3 threads:

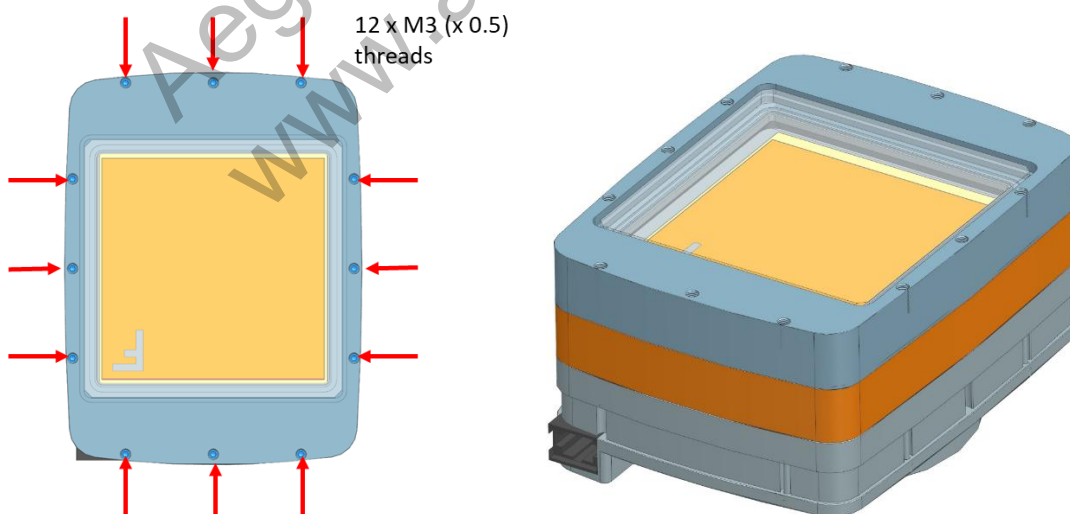

The MX377 is designed so that a customer-specific flange can be used instead of the M95 thread. This flange can be fixed with up to 12 M3 screws in stainless steel, which guarantees a sufficient mechanical connection.

For safety reasons, the screws should be screwed into the thread by max. 5.5 mm.

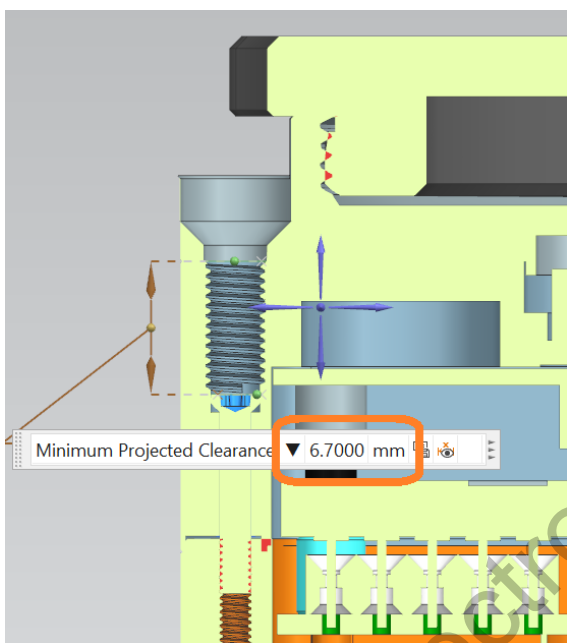
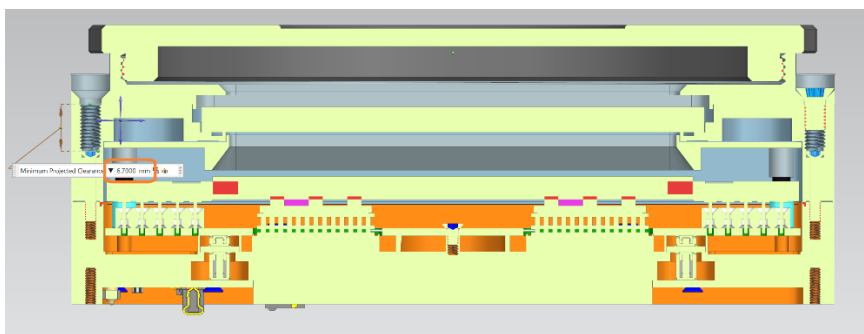

The FRONT component is the sensor chamber. FRONT and MID are bonded together (with a thin Indium layer) in a highly vacuum-resistant manner.

As a part of the production, each camera is tested for vacuum leak detection. The camera sensor chamber is evacuated by our leak detection equipment and Helium is applied externally over the camera by a Helium blow gun. Any potential vacuum sealing defect would then result in Helium being detected by the leak detector.

The sensor chamber is finally filled with XENON to protect the sensor, which can be cooled below the freezing point of water.

## 6.2. Camera dimension

Two different camera housings are available. They use the same camera core

- Front mechanics
- Sealed sensor chamber
- Electronics and housing around that components

This unit can be combined with two cooling units:

- Active fan
- Water cooling

### 6.2.1. Front view

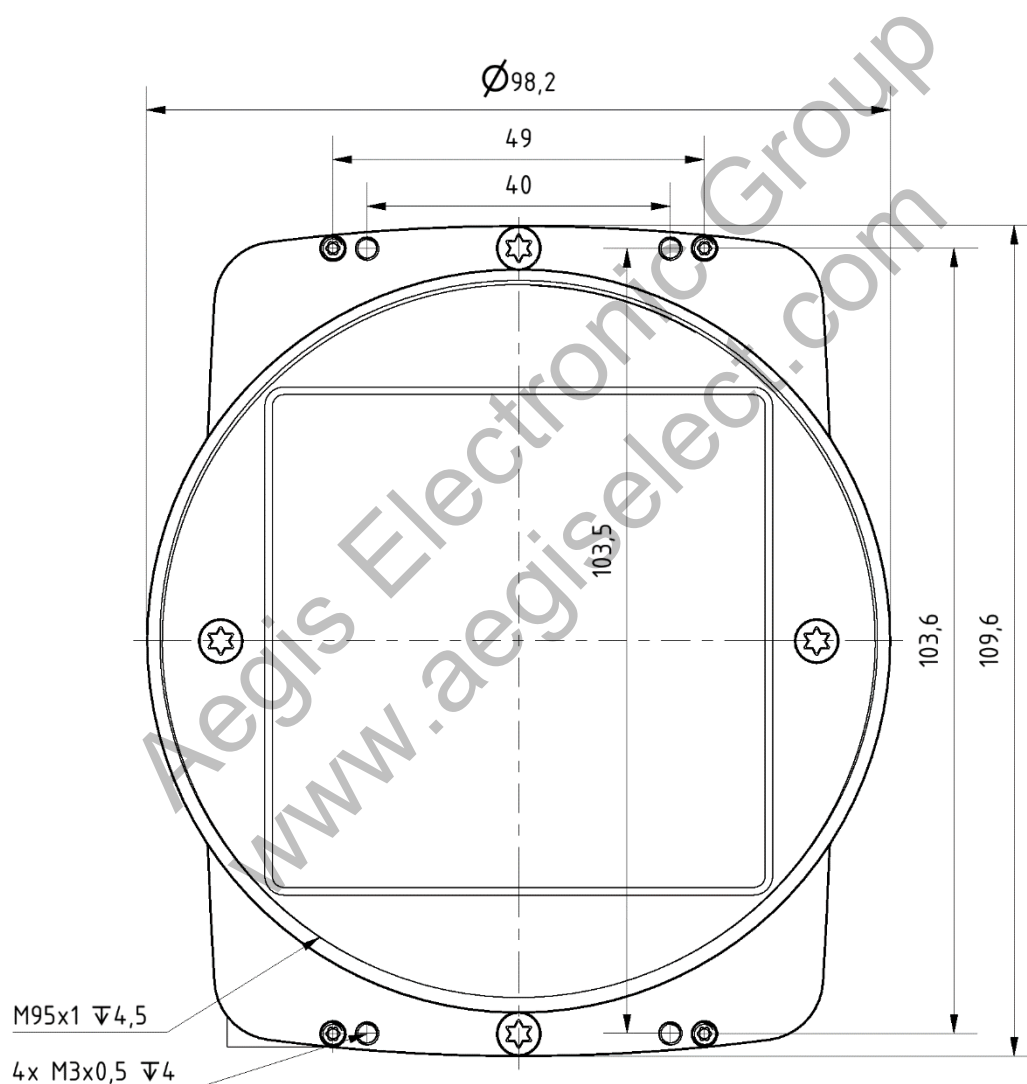

The 4 M3.0x0.5mm screw threads can be used as mounting holes for the MX377.

## 6.2.2. Distances between sensor surface (focal plane) and camera front / filter glass

The sensor filter glass is removed before installation in the camera. In the following detailed drawings, the sensor is only shown with the ceramic carrier plate, the sensor-die (and the connection pins) for simplification.

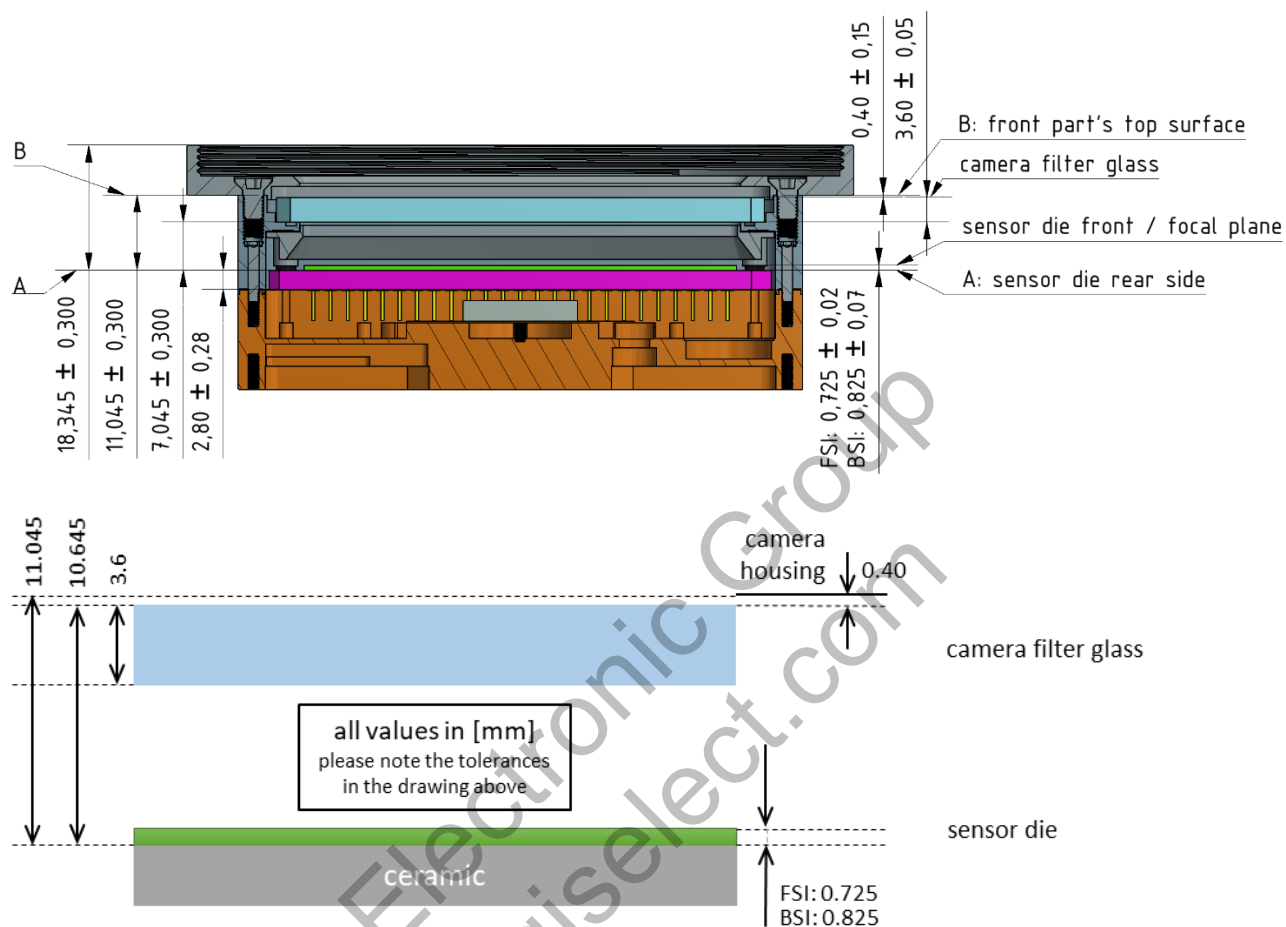

The camera filter window is an AR coated sapphire glass with a refractive index (nd) of 1.77.

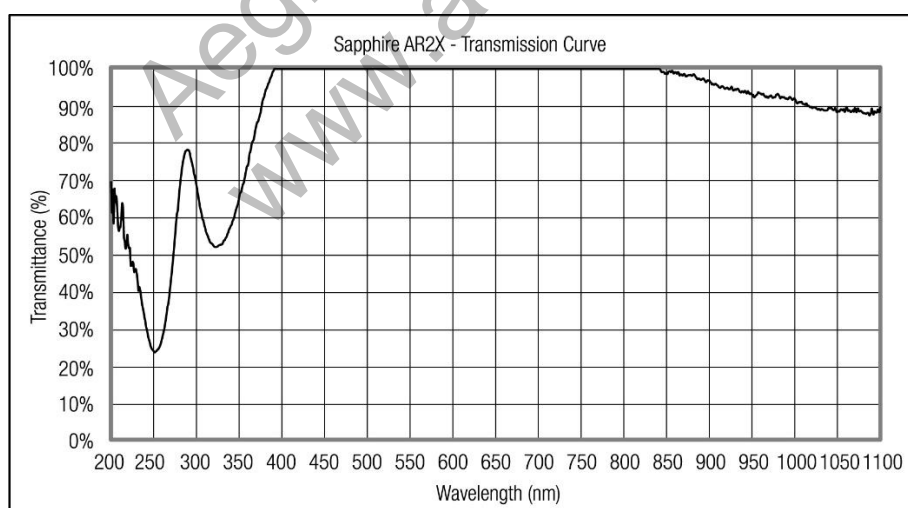

Filter window Sapphire AR2x Transmission Curve

Filter	Coating	Thickness
Sapphire filter	ARx2	3.6 mm

Sapphire filter window parameter

6.2.3. Camera dimensions – Air cooled version

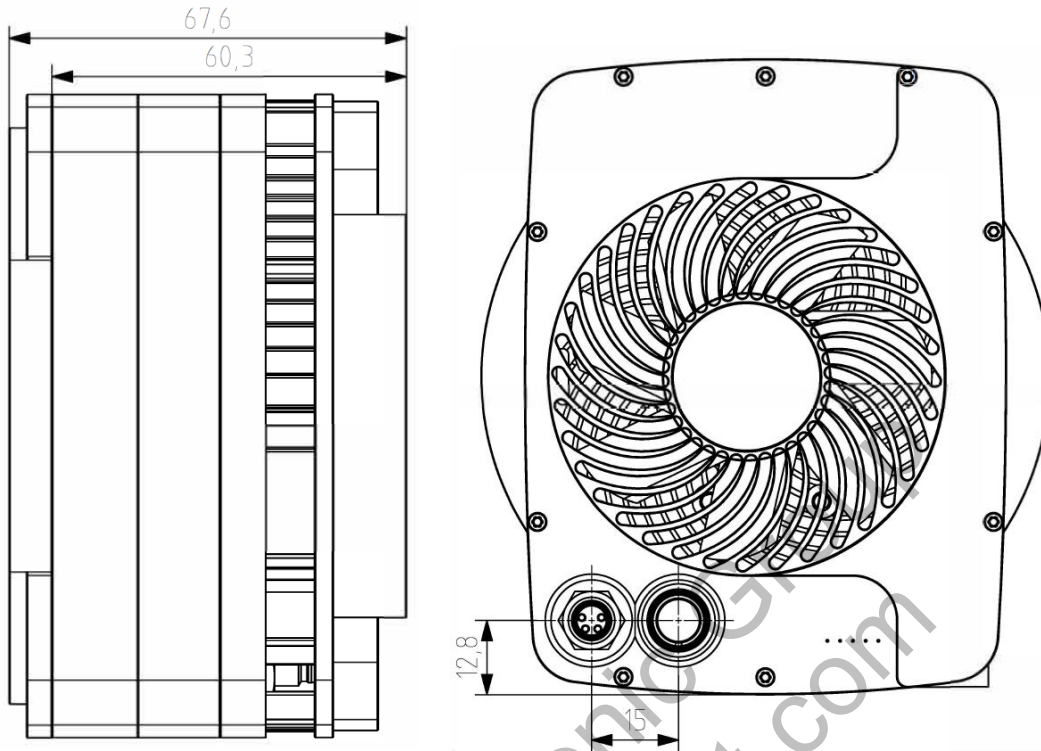

6.2.4. Camera dimensions – Liquid cooled version

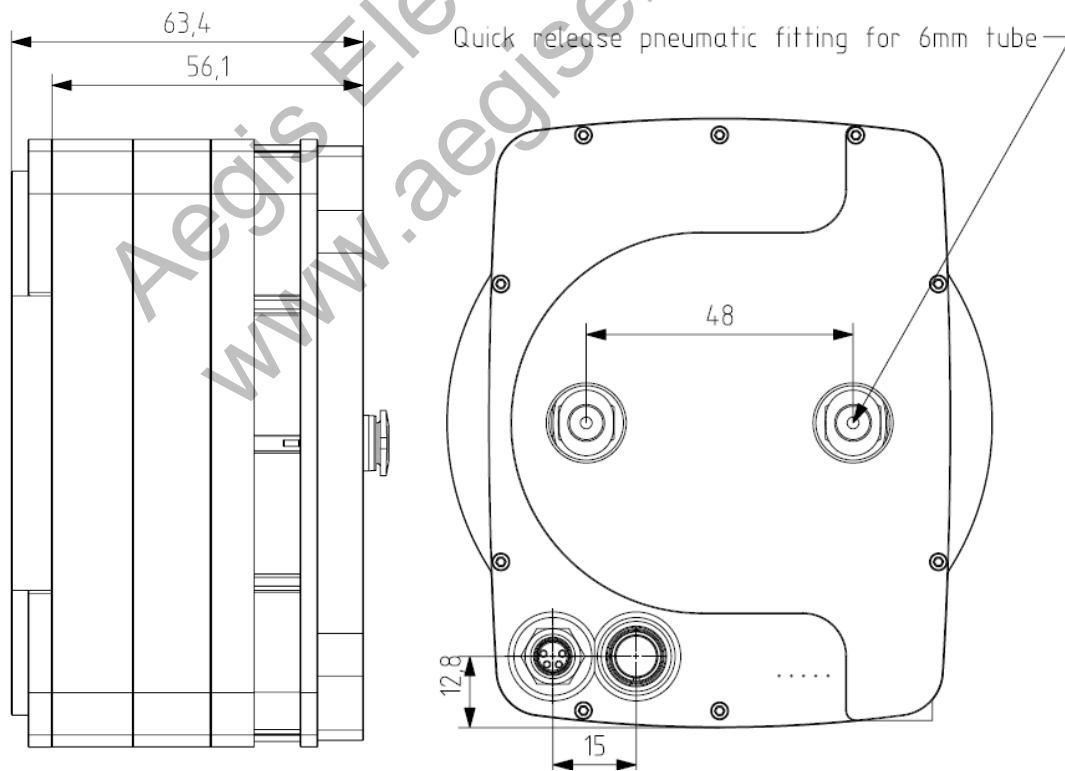

## 6.3. Water cooling

### 6.3.1. Push-in fittings

The water-cooled models of these cameras are equipped with push-in fittings designed for connections using 6mm OD tubes for water cooling purposes. Presently, there are two hardware revisions for the water cooling system, each employing distinct push-in fittings. These fittings can be identified by the material and the color of their collet/release ring.

REV1 cameras used Festo push-in-fittings QSM-M5-6, part number 153306:



Fitting model	Festo QSM-M5-6, part number 153306
Maximum operating pressure	0.6 MPa
Operating temperature range	-10 °C to 80 °C
Tube OD	6 mm
Tubing seal material	NBR
Housing material	Brass, nickel-plated

Table 1 REV1 fitting specs (for full specification refer to manufacturer's website)

REV2 cameras uses PISCO push-in-fittings SSC6-M5:



Fitting model	PISCO SSC6-M5
Maximum operating pressure	1.0 MPa
Operating temperature range	-15 °C to 120 °C
Tube OD	6 mm
Tubing seal material	FKM
Housing material	SUS316, stainless steel

Table 2 REV2 fitting specs (for full specification refer to manufacturer's website)

### 6.3.2. Connecting and disconnecting the tubes

There are various 6mm OD tubes available from multiple manufacturers that can be used with the camera. It is recommended to consult the websites of the push-in fitting manufacturer for a list of compatible tubes and specific tube specifications necessary to ensure a leak-free connection. Adherence to their provided installation instructions is crucial. Always conduct a leak inspection after making tube connections. XIMEA disclaims any liability for damages resulting from improper installation. Following these guidelines correctly is vital for protecting your equipment and ensuring its peak performance.

XIMEA has conducted tests and endorses the use of PISCO brand tubes (part number UCQ06-2F-20-C) along with insert rings (part number WR0640) for creating secure and leak-proof connections. The recommended procedure for connecting and disconnecting tubes is as follows:

#### Connecting

- Begin by inserting the insert rings into the tubes.

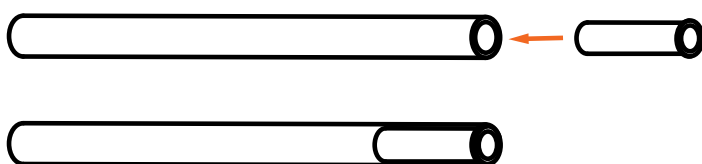

- Ensure the camera is powered off. Then, insert the tube into the Push-In Fitting until it is fully seated. The collet/release ring will automatically secure the tube, and the elastic sleeve will form a seal around it.

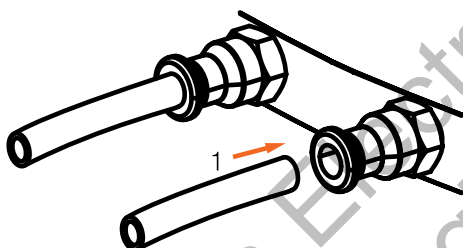

- Gently pull on the tube to verify it is securely fixed and cannot be removed easily.
- Start water supply and inspect for any leaks.
- If no leaks are detected, it is safe to power on the camera.

#### Disconnecting

- Turn off the camera and halt the water supply.
- Press the collet (release ring) towards the fitting (Step 1)
- While keeping the collet pressed, gently push the tube further into the fitting (Step 2), then pull it out to disconnect (Step 3).

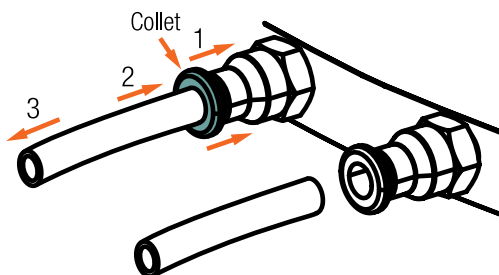

### 6.3.3. Pressure loss with longer water tubes

Long liquid hoses with a small diameter lead to significant pressure loss. To reduce the pressure loss significantly it is recommended to use a thicker hose for the long distance after a (short) hose directly on the camera with the intended diameter (OD=6mm).

Hose reduction adapters can be used for this purpose:

XIMEA uses the following setup in their lab:



#### 6mm OD water hose between chiller and camera

Components on the chiller side

Laird Chiller 385755-001. It uses a specific CPC quick connector

LCD24004BSPT adapter from CPC to 1/4"

QSF-1/4-6-B (1/4" thread to tube fitting)

## 7. Data connection

The MX377 has a PCIe Gen3 4 lanes (X4G3) data connection.

For details on MTP data connection, see at: <http://ximea.com/files/MTP-cabling-Whitepaper.pdf>

### 7.1. Camera connector

An aligned, male MTP connection with 12 optical fibers is used.

### 7.2. Host adapter

Opposed male MTP connectors with 12 optical fibers are used in our standard host adapters.

1-, 2- and 4-port host adapters are available.

Please note: A long PCIe x16 slot is required for operation.



Example: 2 port host adapter PEX4-G3-MTP-X2

### 7.3. MTP cable

Standard MTP-trunk cables with 12-fibers are used.

Female MTP sockets are required at both ends.

The cable used must be an MTP type A cable.

## 8. MX377 trigger-/IO-system

The MX377 cameras offer several IO-ports:

- 2 \* Opto-isolated Input
- 2 \* Opto-isolated Open-collector Output
- 8 \* non-isolated Input/Output

### 8.1. Location

The IO interface receptacle is located on the back of the camera and marked with "IO/PWR".



### 8.2. Connector

The connector is a female 20 pin connector Hirose HR25-9TR-20SA(71).

Mating connectors: Hirose HR25-9TP-20P(72) and HR25-9TP-20PC(72) plugs.

### 8.3. IO Connector Pinning

Pinning of the IO connector (camera):

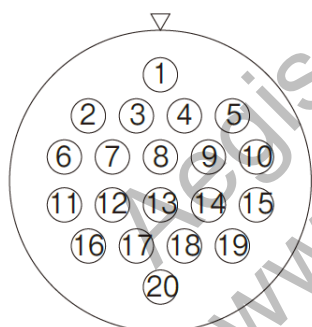

Pin	Signal	Technical description
1	GND	Common ground for non-isolated Input/Output
2	INOUT1	non-isolated Input/Output 1
3	INOUT2	non-isolated Input/Output 2
4	INOUT3	non-isolated Input/Output 3
5	INOUT4	non-isolated Input/Output 4
6	AUX PWR GND	Ground for power supply
7	INOUT8	non-isolated Input/Output 8
8	IN2	Opto-isolated Input 2
9	INOUT7	non-isolated Input/Output 7
10	AUX PWR	Power Supply 12-24V
11	AUX PRW GND	Ground for power supply

12	INOUT5	non-isolated Input/Output 5
13	IN3	Opto-isolated Input 3
14	INOUT6	non-isolated Input/Output 6
15	AUX PWR	Power Supply 12-24V
16	OUT3 GND	Ground for Opto-Isolated Output 2
17	OUT3	Opto-isolated Output 2
18	OUT2 GND	Ground for Opto-Isolated Output 1
19	OUT2	Opto-isolated Output 1
20	IN GND	Common ground for Opto-Isolated inputs

Note: The opto-isolated ports IN1 and OUT1 are internally connected to the Firefly-connector and are not accessible for the -MTP camera version.

#### 8.4. Non-isolated digital Input/Output lines (INOUT)

Item	Parameter	Note
Number of digital lines	8	Each line can be configured by application separately as input or output
Maximal input voltage	24V DC	
Common pole	YES	
Effect of incorrect input terminal connection	Reverse voltage polarity protected	
Effects when withdrawing/inserting input module under power	no damage, no lost data	
Protection	short-circuit / over-current / Reverse voltage	
Maximal output sink current	30 $\mu$ A	Maximal advised load = 60kOhm ouput impedance 9.4kOhm
Inductive loads	false	
Output Level logical 0	< 0.4V	Load 100kOhm
Output Level logical 1	> 2.1V	Load 100kOhm
Output delay - rising edge	120ns	Load 100kOhm 10pF threshold 1.8V
Output delay - falling edge	150ns	Load 100kOhm 10pF threshold 0.5V
Input Impedance- minimum	10kOhm	
Input Level for logical 0	< 0.7V	
Input Level for logical 1	> 1.8V	
Input debounce filter	NO	
Input delay - rising edge	<50ns	VINPUT=3.3V
Input delay - falling edge	<50ns	VINPUT=3.3V
Input functions	Trigger	Rising or falling edge are supported for trigger

#### 8.5. Optically isolated Digital Input (IN)

Item	Parameter	Note
Maximal input voltage	24V DC	
Common pole	YES	IN GND
Effect of incorrect input terminal connection	Reverse voltage polarity protected	

Effects when withdrawing/inserting input module under power	no damage, no lost data	
Maximal recommended cable length	10m	
Input Level for logical 0	Voltage < 2.5V / Current < 1mA	
Input Level for logical 1	Voltage > 4.0V / Current > 1mA	
Input debounce filter	No / Current > 1mA	
Input delay - rising edge	TBD (1.7±0.2 μs)	VINPUT=10V, AMBIENT=25°C
Input delay - falling edge	TBD (10.7±0.2 μs)	VINPUT=10V, AMBIENT=25°C
Number of inputs	2	VINPUT=10V, AMBIENT=25°C
External trigger mapping	YES	
Input functions	Trigger	Rising or falling edge are supported for trigger

(TBD: Needs to be measured)

## 8.6. Optically isolated Digital Output (OUT)

Item	Parameter	Note
Maximal open circuit voltage	24V DC	
Number of outputs	2	
Output port type	Open collector NPN	
Common pole	false	
Protection	short-circuit / over-current / Reverse voltage	
Protection circuit	PTC Resettable Fuse	
Maximal sink current	150mA	
Trip current	300mA	Self-restarting when failure mode current disconnected
Inductive loads	false	
Effect of incorrect output terminal connection	Protected against reverse voltage connection	
Maximal output dropout	TBD	Sink current TBD mA
Input delay - rising edge	TBD	VOUTPUT=10V, AMBIENT=25°C
Input delay - falling edge	TBD	VOUTPUT=10V, AMBIENT=25°C
Strobe output mapping	YES	

(TBD: Needs to be measured)

## 8.7. Trigger cable CBL-MX377-SYNC-3M0

### 8.7.1. White (XIMEA pre-production)

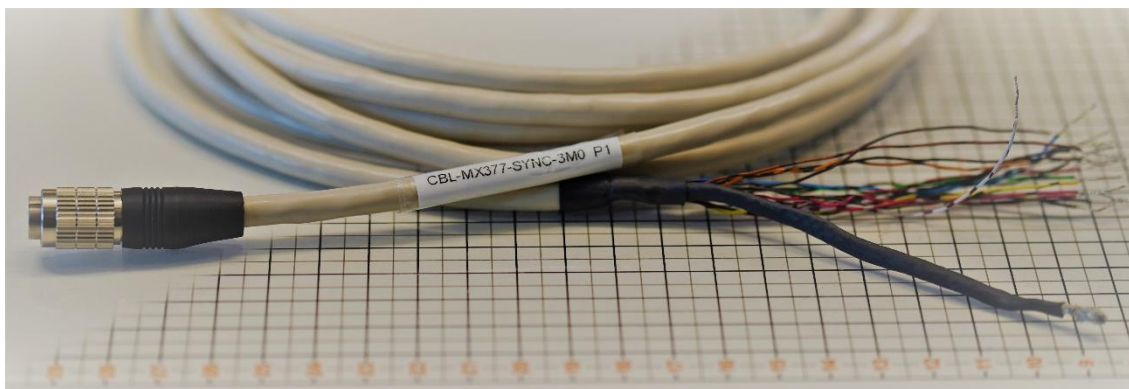

Wiring diagram:

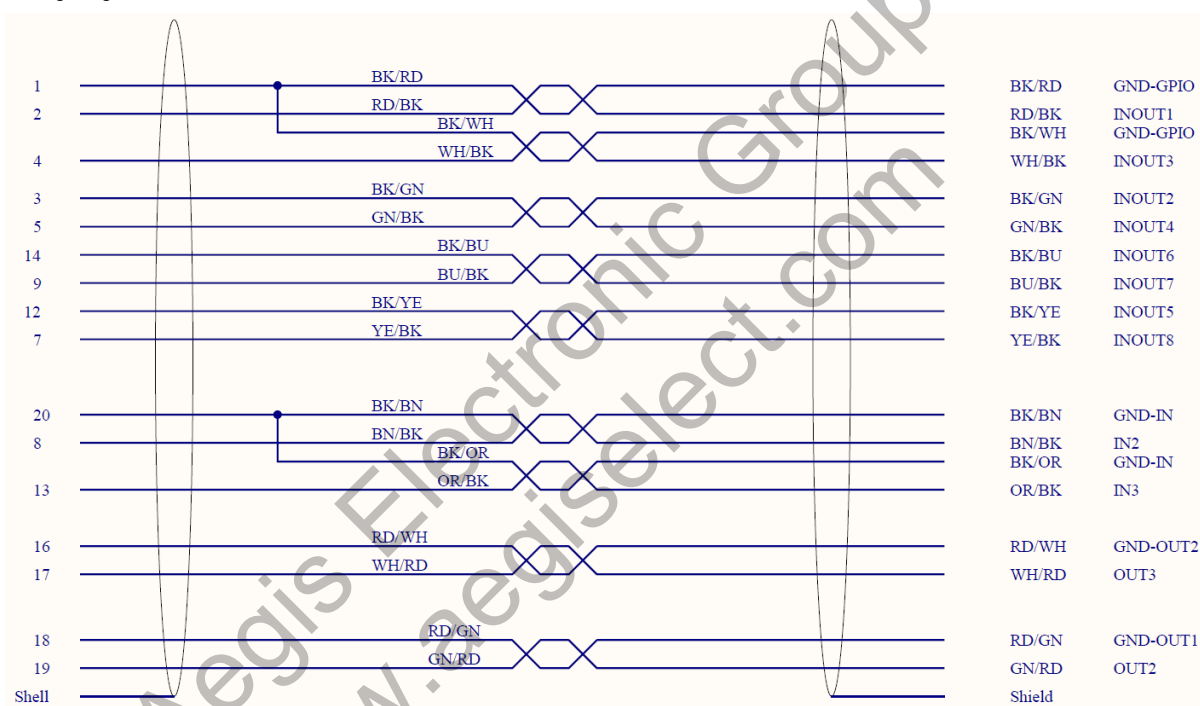

Example of wire identification:

BK/RD = Black (Solid) / Red (Band)

RD/BK = Red (Solid) / Black (Band)

8.7.2. Black (series production)

Wiring diagram:

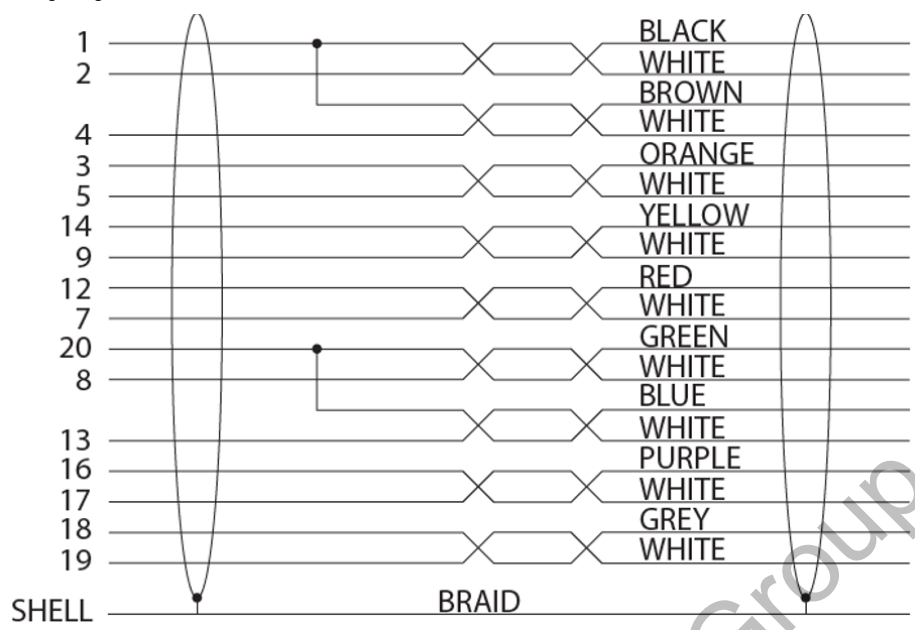

Aegis Electronic Group  
www.aegiselect.com

## 9. MX377 power connector

### 9.1. Location

The power connector is located on the back of the camera and marked with "PWR".



### 9.2. Connector

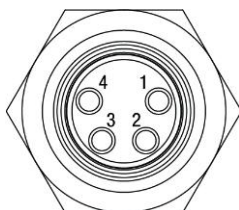

The connector is a male 4 pin connector Binder 09-3391-81-04.

Mating connectors: Binder - 99-3376-00-04, 99-3376-110-04, 99-3378-00-04.

Aegis Electronic Group  
www.aegiselect.com

## 10. Quickstart Guide



Components needed to use a XIMEA MX377 camera

### 10.1. Hardware Setup

#### 10.1.1. Essential Components

- CBL-MTP-X4G3-FF: trunk MTP cable, female-female, 12 fibers
- PSU-GSM60B24-P1J: desktop power supply (60W, 24V)
- Standard power cord for your region
- PEX4-G3-MTP: PCIe Gen.3 x4 host adapter for MTP cables
- MX377MR-GP: The camera itself
- CBL-MX377-PWR: AUX power cable for MX377 cameras

#### 10.1.2. Connecting the Components

- Install the PCIe host adapter in a PCIe Slot of your host computer. Consult the documentation provided by your motherboard or PC manufacturer for information on how to install a PCIe device.
- Remove the protective caps from the MTP connectors on the camera, host adapter and cable.
- Connect one side of the MTP cable to the camera and the other and to the host adapter.
- Connect the power supply to an appropriate wall socket (100-240V AC, 50/60 Hz).
- Connect the AUX power cable to the camera
- Connect the power supply cable and the AUX power cable. The power LEDs on the camera should now light up and the fan may turn on.
- You can now boot up your host computer.

## 10.2. Installing the XIMEA Software Package

Download the XIMEA software package for Windows using the following link:

[https://www.ximea.com/support/wiki/apis/XIMEA\\_Windows\\_Software\\_Package](https://www.ximea.com/support/wiki/apis/XIMEA_Windows_Software_Package)

To make sure you get access to all the latest features of our software, we recommend using the Beta version of the XIMEA Software Package.



To install the software package, follow the instructions in the installer as described on the website. Note that you will need administrator privileges to run the installer. After the installation, the XIMEA CamTool icon will appear on your desktop.

## 10.3. Getting Images from Your Camera in CamTool

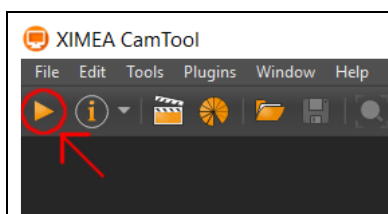

To acquire images from your camera and show them on screen, just click the Start Acquisition button in CamTool.

## 10.4. Basic Settings in CamTool

- Downsampling to a lower resolution.
- Data format
- Region of interest (ROI); Use the small arrow on the right to open the dialog for the definition of a ROI.
- Automatic exposure; Disable to set exposure manually.
- Advanced settings for automatic exposure.
- Set up a special region of interest used for automatic exposure.
- Manual Exposure setting.
- Analog gain settings.
- Digital gain settings. Does not apply to MX377 cameras.
- Enable or disable automatic white balance. The automatic white balance will continuously adjust white balance. Does not apply to MX377 cameras.
- Perform manual white balance. Click this button while the camera is pointed at a white surface, to determine the parameters for a static white balance. Does not apply to MX377 cameras.

## 11. MX377 system overview

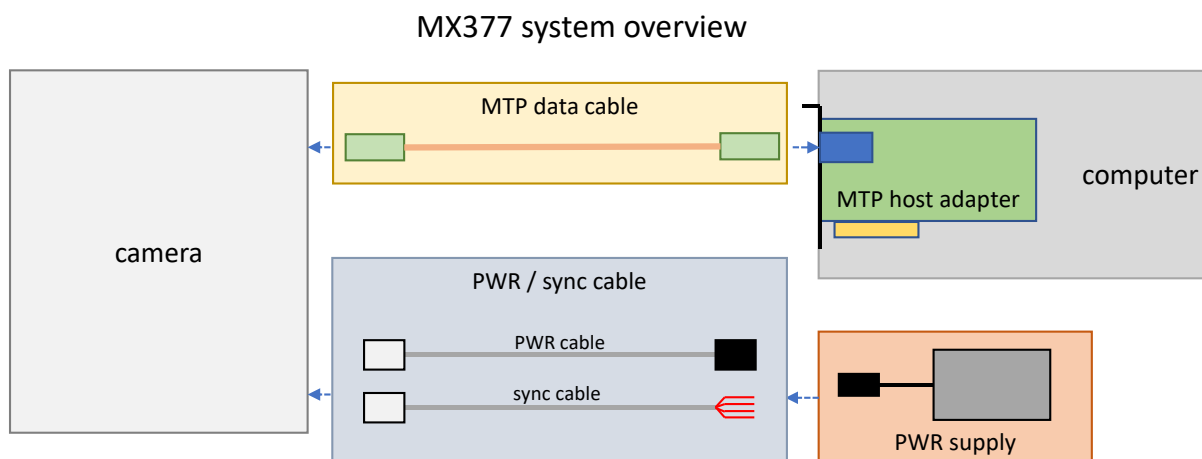

### 11.1. Accessories / models

Model	Description
MX377MR-GP-F0-X4G3-MTP <sup>ES)</sup> MTO)	PCIe Gen3 x4, Air cooled scientific 37.7MP (sensor grade 0) B/W camera, aligned MTP connector
MX377MR-GP-F0-X4G3-MTP-W <sup>ES)</sup> MTO)	PCIe Gen3 x4, Water cooled scientific 37.7MP (sensor grade 0) B/W camera, aligned MTP connector
MX377MR-GP-F1-X4G3-MTP <sup>ES)</sup> MTO)	PCIe Gen3 x4, Air cooled scientific 37.7MP (sensor grade 1) B/W camera, aligned MTP connector
MX377MR-GP-F1-X4G3-MTP-W <sup>ES)</sup> MTO)	PCIe Gen3 x4, Water cooled scientific 37.7MP (sensor grade 1) B/W camera, aligned MTP connector
MX377MR-GP-FE-X4G3-MTP <sup>ES)</sup> MTO)	PCIe Gen3 x4, Air cooled scientific 37.7MP (sensor grade ES) B/W camera, aligned MTP connector
MX377MR-GP-FE-X4G3-MTP-W <sup>ES)</sup> MTO)	PCIe Gen3 x4, Water cooled scientific 37.7MP (sensor grade ES) B/W camera, aligned MTP connector
MX377MR-GP-B0-X4G3-MTP <sup>ES)</sup> MTO)	PCIe Gen3 x4, Air cooled scientific 37.7MP (sensor grade 0) B/W backside illuminated camera, aligned MTP connector
MX377MR-GP-B0-X4G3-MTPV-W <sup>ES)</sup> MTO)	PCIe Gen3 x4, Water cooled scientific 37.7MP (sensor grade 0) B/W backside illuminated camera, aligned axial MTP connector
MX377MR-GP-B0-X4G3-MTP-W <sup>ES)</sup> MTO)	PCIe Gen3 x4, Water cooled scientific 37.7MP (sensor grade 0) B/W backside illuminated camera, aligned MTP connector
MX377MR-GP-B1-X4G3-MTP <sup>ES)</sup> MTO)	PCIe Gen3 x4, Air cooled scientific 37.7MP (sensor grade 1) B/W backside illuminated camera, aligned MTP connector
MX377MR-GP-B1-X4G3-MTPV-W <sup>ES)</sup> MTO)	PCIe Gen3 x4, Water cooled scientific 37.7MP (sensor grade 1) B/W backside illuminated camera, aligned axial MTP connector
MX377MR-GP-B1-X4G3-MTP-W <sup>ES)</sup> MTO)	PCIe Gen3 x4, Water cooled scientific 37.7MP (sensor grade 1) B/W backside illuminated camera, aligned MTP connector
MX377MR-GP-BE-X4G3-MTP <sup>ES)</sup> MTO)	PCIe Gen3 x4, Air cooled scientific 37.7MP (sensor grade ES) B/W backside illuminated camera, aligned MTP connector
MX377MR-GP-BE-X4G3-MTP-W <sup>ES)</sup> MTO)	PCIe Gen3 x4, Water cooled scientific 37.7MP (sensor grade ES) B/W backside illuminated camera, aligned MTP connector

Notes: ES: Engineering Sample MTO: make to order

Model Accessory	Description
CBL-MTP-X4G3-FF-5M0 <sup>MT0</sup>	5.0m optical patch / trunk MTP cable, female-female, 12 fibers (for 4 lane PCIe connections), ANSI/TIA Type-A
CBL-MTP-X4G3-FF-10M0 <sup>MT0</sup>	10.0m optical patch / trunk MTP cable, female-female, 12 fibers (for 4 lane PCIe connections), ANSI/TIA Type-A
CBL-MTP-X4G3-FF-20M0 <sup>MT0</sup>	20.0m optical patch / trunk MTP cable, female-female, 12 fibers (for 4 lane PCIe connections), ANSI/TIA Type-A
CBL-MTP-X4G3-FF-30M0 <sup>MT0</sup>	30.0m optical patch / trunk MTP cable, female-female, 12 fibers (for 4 lane PCIe connections), ANSI/TIA Type-A
CBL-MX377-PWR-3M0 <sup>MT0</sup>	3.0m AUX power cable for MX377 cameras
CBL-MX377-SYNC-3M0 <sup>MT0</sup>	3.0m I/O Sync cable for MX377 cameras
HA-1P-X4G3-MTP-X8G3 <sup>MT0</sup>	XIMEA 1-Port PCIe Gen.3 x4 host adapter for fiber optics with opposed MTP connector
HA-2P-X4G3-MTP-X8G3 <sup>MT0</sup>	XIMEA 2-Port PCIe Gen.3 x4 host adapter for fiber optics with opposed MTP connector
ME-ADPT-MX377-T <sup>MT0</sup>	tripod mount for MX377 cameras
PSU-TR9CI5000CCP <sup>MT0</sup>	desktop power supply (120W, 24V) for MX377
CBL-PWR-C13-EU <sup>MT0</sup>	power cord (EU) for PSU-XCX-280W-C6P and PSU-TR9CI5000CCP
CBL-PWR-C13-US <sup>MT0</sup>	power cord (US) for PSU-XCX-280W-C6P and PSU-TR9CI5000CCP

Aegis Electronic Group  
www.aegiselect.com

## 12. Additional info

Camera brochure:

<https://www.ximea.com/files/brochures/MX377-High-resolution-Large-sCMOS-camera-brochure.pdf>

The two camera versions are described separately

FSI:

<https://www.ximea.com/en/products/xilab-application-specific-custom-oem/scientific-scmos-front-and-back-illuminated/large-scmos-sensor-gpixel-gsense6060-camera>

BSI:

<https://www.ximea.com/en/products/xilab-application-specific-custom-oem/scientific-scmos-with-back-illumination/large-scmos-sensor-gpixel-gsense6060bsi-camera>

An overview of our sCMOS cameras can be found here:

<https://www.ximea.com/en/products/xilab-application-specific-custom-oem/scientific-scmos-cameras-with-front-back-illumination>

We have collected further information on our cameras with sCMOS sensors at:

[https://www.ximea.com/support/projects/allprod/wiki/SCMOS\\_cameras\\_with\\_Back\\_illumination](https://www.ximea.com/support/projects/allprod/wiki/SCMOS_cameras_with_Back_illumination)

Whitepaper about MTP cabling: <http://ximea.com/files/MTP-cabling-Whitepaper.pdf>

XIMEA API/SDK:

05/12/2020: The API for the MX377 is currently under intensive development. Please use the beta API.

Windows:

[https://www.ximea.com/support/wiki/apis/XIMEA\\_API\\_Software\\_Package](https://www.ximea.com/support/wiki/apis/XIMEA_API_Software_Package)

Linux:

[https://www.ximea.com/support/wiki/apis/XIMEA\\_Linux\\_Software\\_Package](https://www.ximea.com/support/wiki/apis/XIMEA_Linux_Software_Package)

Direct download links:

Beta: <https://www.ximea.com/support/documents/14>

Stable: <https://www.ximea.com/support/documents/4>

xiAPI, overview, link to the xiAPI Manual:

C/C++ <https://www.ximea.com/support/wiki/apis/XiAPI>

C#/NET <https://www.ximea.com/support/wiki/apis/XiAPINET>

### 13. Revision history

Version	Date	Notes
V0.14	05/24/2020	Formatted
V0.15	08/11/2020	Review results and new 14-bit HDR modes included. Trigger system described.
V0.16		New review, new water-cooling components described. New measurements added
V0.17	09/16/2021	Sensor description extended.
V0.18	01/09/2023	Product list in chapter 11.1 updated, list of mating connectors in chapter 8.2 corrected.
V0.19	03/27/2024	Added specification for new revision of tube fittings and tube connection guide
V0.20	03/27/2024	Sensor defects specifications corrected.
V0.21	05/06/2025	Added Transmission curve graph of filter window (chapter 6.2.2)

< END OF THE DOCUMENT >

Aegis Electronic Group  
www.aegiselect.com