



xiQ-S7

[ksi-kju:] or [sai-kju:]

- USB3 Vision ultra-compact cameras

Ximea cameras •
Technical Manual •
Version v240920 •

Introduction

About this manual

Dear customer,

Thank you for purchasing a product from XIMEA.

We hope that this manual can answer your questions, but should you have any further queries or if you wish to claim a service or warranty case, please contact your local dealer or refer to XIMEA Support on our website:

www.ximea.com/support

The purpose of this document is to provide a description of Ximea cameras and to describe the correct way to install related software, drivers and run it successfully. Please read this manual thoroughly before operating your new Ximea cameras for the first time. Please follow all instructions and observe the warnings.

This document is subject to change without notice.

About XIMEA

XIMEA is one of the worldwide leaders for innovative camera solutions with a 30-year history of research, development and production of digital image acquisition systems. Based in Slovakia, Germany and the US, with a global distributor network, XIMEA offers their cameras worldwide. In close collaboration with customers XIMEA has developed a broad spectrum of technologies and cutting-edge, highly competitive products.

XIMEA's camera centric technology portfolio comprises a broad spectrum of digital technologies, from data interfaces such as USB 2.0, USB 3.1 and PCIe to cooled digital cameras with CCD, CMOS and sCMOS sensors, as well as X-ray cameras.

XIMEA has three divisions – generic machine vision and integrated vision systems, scientific imaging and OEM/custom.

Our broad portfolio of cameras includes thermally stabilized astronomy and x-ray cameras, as well as specialty cameras for medical applications, research, surveillance and defense.

Standard conformity

CE conformity



Figure 1: Standard conformity CE logo

The camera models listed below comply with the requirements of the EC EMC Directive 2014/30/EU regarding the electromagnetic compatibility of equipment.

Certified camera models include MQ013CG-E2-S7, MQ013MG-E2-S7, MQ013RG-E2-S7, MQ013RG-ON-S7, MQ013MG-E2-S7-NIO, MQ013CG-E2-S7-NIO, MQ013RG-E2-S7-NIO, MQ013CG-ON-S7, MQ013MG-ON-S7, MQ022RG-CM-S7, MQ022CG-CM-S7, MQ022MG-CM-S7, MQ042CG-CM-S7, MQ042RG-CM-S7, MQ042MG-CM-S7 and MQ042MG-CM-S7-NIO.

UKCA conformity



Figure 2: Standard conformity UKCA logo

We declare that the products listed below comply with the requirements of Directive 2014/35/EU (Low Voltage Directive) and Directive 2014/30/EU (Electromagnetic Compatibility).

All tests are based on EU rules and standards valid before January 1, 2021 (Brexit). The harmonized EU product standards were converted into UK designated standards on exit day. Based on that, these products are UKCA compliant.

Certified camera models include MQ013CG-E2-S7, MQ013MG-E2-S7, MQ013RG-E2-S7, MQ013RG-ON-S7, MQ013MG-E2-S7-NIO, MQ013CG-E2-S7-NIO, MQ013RG-E2-S7-NIO, MQ013CG-ON-S7, MQ013MG-ON-S7, MQ022RG-CM-S7, MQ022CG-CM-S7, MQ022MG-CM-S7, MQ042CG-CM-S7, MQ042RG-CM-S7, MQ042MG-CM-S7 and MQ042MG-CM-S7-NIO.

FCC conformity



Figure 3: Standard conformity FCC logo

The camera models listed below have been tested and found to comply with Part 15 of the FCC rules, which states that:

Operation is subject to the following two conditions:

1. This device may not cause harmful interference.
2. This device must accept any interference received, including interference that may cause undesired operation.

This equipment has been tested and found to comply with the limits for a Class A digital device, pursuant to Part 15 of the FCC rules. These limits are designed to provide reasonable protection against harmful interference when the equipment is operated in a commercial environment. This equipment generates, uses, and can radiate radio frequency energy and, if not installed and used in accordance with the instruction manual, may cause harmful interference to radio communications. Operation of this equipment in a residential area is likely to cause harmful interference, in which case the users will be required to correct the interference at their own expense.

You are cautioned that any changes or modifications not expressly approved in this manual could void your authority to operate this equipment under the above jurisdictions. The shielded interface cable recommended in this manual must be used with this equipment to comply with the limits for a computing device pursuant to Subpart J of Part 15 of FCC Rules.

Certified camera models include MQ013CG-E2-S7, MQ013MG-E2-S7, MQ013RG-E2-S7, MQ013RG-ON-S7, MQ013MG-E2-S7-NIO, MQ013CG-E2-S7-NIO, MQ013RG-E2-S7-NIO, MQ013CG-ON-S7, MQ013MG-ON-S7, MQ022RG-CM-S7, MQ022CG-CM-S7, MQ022MG-CM-S7, MQ042CG-CM-S7, MQ042RG-CM-S7, MQ042MG-CM-S7 and MQ042MG-CM-S7-NIO.

Camera Sub-Assemblies

The “semi” housed camera models do not comply with CE/FCC/Class A limits (Canada) regulations. The system integrator (customer) is liable for compliance with CE/FCC/ Class A limits (Canada) regulations.

This text applies to MQ013CG-E2-S7-FL, MQ013CG-E2-S7-FV, MQ013MG-E2-S7-FV, MQ013RG-E2-S7-FL, MQ013RG-E2-S7-FV, MQ013MG-E2-S7-FL, MQ022CG-CM-S7-FL, MQ022RG-CM-S7-FL, MQ022MG-CM-S7-FL, MQ042CG-CM-S7-FL and MQ042MG-CM-S7-FL.

RoHS conformity



Figure 4: Standard conformity RoHS logo

The products described in this technical manual comply with the RoHS (Restriction of Hazardous Substances) Directive 2015/863/EU.

WEEE conformity



Figure 5: Standard conformity WEEE logo

The products described in this technical manual comply with the WEEE (Waste Electrical and Electronic Equipment) Directive 2012/19/EU.

AIA standard USB3 Vision



The xiQ cameras are compliant with the **USB 3 Vision** standard.

GenICam GenTL API



The **GenICam/GenTL** standard offers a device-agnostic interface for the acquisition of images and other data types, as well as for communication with devices. This enables each XIMEA camera to function as a GenTL Producer, facilitating the capture of images through a standardized transport layer interface.

Contents

About this manual	2
About XIMEA	2
Contact XIMEA	2
Standard conformity	3
Helpful links	5
1 xiQ camera series	9
1.1 What is xiQ	9
1.2 Advantages	9
1.3 Camera applications	10
1.4 Common features	10
1.5 Model nomenclature	11
1.6 Models and sensors overview	12
1.7 Accessories overview	13
2 Hardware specification	14
2.1 Power supply	14
2.1.1 Power input	14
2.2 General specification	16
2.2.1 Environment	16
2.3 Lens mount	17
2.3.1 C/CS-mount	17
2.4 Mounting points	18
2.4.1 Screws	18
2.5 Optical path	19
2.6 Sensor and camera characteristics	23
2.6.1 Sensor and camera parameters	23
2.6.2 Image quality parameters	25
2.6.3 Sensor read-out modes	31
2.6.4 Quantum efficiency curves	33
2.7 Mechanical characteristics	36
2.7.1 Dimensions and mass	36
2.7.2 Dimensional drawings	38
2.8 User interface – LEDs	46
2.9 Camera interface	47
2.9.1 USB 3 Gen1 micro-B	47
2.9.2 Flex cable interface	49
2.10 Digital inputs / outputs (GPIO) interface	50
2.10.1 Optically isolated Digital Input (IN)	52
2.10.2 Optically isolated Digital Output (OUT)	54
2.11 Accessories	55
2.11.1 CBL-U3-xM	55
2.11.2 CBL-U3-3MO-ANG	56
2.11.3 CBL-MQ-FL-xM	58
2.11.4 CBL-USB3FLEX-xM	58
2.11.5 CBL-S-M5-3P-PT-xM	59
2.11.6 CBL-S-PB3-PT-OM30	60
2.11.7 BOB-MQ-FL	61
2.11.8 MQ-BRACKET-T	62
2.11.9 USB 3 host adapters	63
3 General features	64
3.1 Camera features	64
3.1.1 ROIs – Region of interest	64
3.1.2 Downsampling modes	64
3.1.3 Image data output formats	65
3.2 Acquisition modes	66
3.2.1 Free-Run	66

3.2.2	Trigger controlled acquisition/exposure	66
3.3	Exposure time	72
3.4	Gain	72
3.5	API Features	73
3.5.1	Exposure – Auto gain	73
3.5.2	White balance	73
3.5.3	Gamma	73
3.5.4	Sharpness	73
3.5.5	Color correction matrix	73
3.5.6	Sensor defect correction	73
3.5.7	HDR	74
4	Operation	77
4.1	System requirements	77
4.1.1	Software requirements	77
4.1.2	API Compatibility	77
4.1.3	Hardware requirements	77
4.2	XIMEA software packages	78
4.2.1	XIMEA Windows software package	78
4.2.2	XIMEA Linux software package	81
4.2.3	XIMEA macOS software package	83
4.3	XIMEA CamTool	86
4.4	XIMEA control panel	87
4.5	Supported vision libraries	88
4.5.1	MathWorks MATLAB	88
4.5.2	MVTec HALCON	88
4.5.3	National Instruments LabVIEW vision library	88
4.5.4	OpenCV	88
4.6	Programming	89
4.6.1	Standard interface	89
4.6.2	xiAPI	89
5	Appendix	93
5.1	Troubleshooting and support	93
5.1.1	Worldwide support	93
5.1.2	Before contacting technical support	93
5.2	Frequently Asked Questions	93
5.3	Product service request (PSR)	94
5.3.1	Step 1 – Contact support	94
5.3.2	Step 2 – Create product service request (PSR)	94
5.3.3	Step 3 – Wait for Product Service Request (PSR) approval	94
5.3.4	Step 4 – Sending the camera to XIMEA	94
5.3.5	Step 5 – Waiting for service conclusion	94
5.3.6	Step 6 – Waiting for return delivery	95
5.4	Safety instructions and precautions	96
5.4.1	Disassembly	96
5.4.2	Mounting / Screws	96
5.4.3	Connections	96
5.4.4	Power supply	96
5.4.5	Environment / protection against water	96
5.4.6	Recommended light conditions	96
5.4.7	Protection of optical components	97
5.4.8	Mechanical loads	97
5.4.9	Camera / lens cleaning	97
5.4.10	Protect against static discharge (Electrostatic discharge (ESD))	97
5.4.11	Safety instruction for board level cameras	97
5.5	Warranty	98
5.5.1	Disclaimer of Warranty	98
5.6	Standard Terms & Conditions of XIMEA GmbH	99

5.7 List of Trademarks	105
5.8 Copyright	105
Glossary	106
List of figures	107
List of tables	109

Aegis Electronic Group
www.aegiselect.com

1 xiQ camera series

1.1 What is xiQ



xiQ **[ksi-kju:]** or **[sai-kju:]** World's smallest USB3 Vision cameras. From 1.3 to 4 Mpx resolution. Able to achieve 210 fps in full resolution or even 1000 fps with downsampling. Lowest power consumption and heat generation. Single PCB - board level versions available lightest in class.

- Extremely small footprint
- Low thermal dissipation
- Single PC board electronics
- USB3 Vision Standard compatible
- sensors: 1.3 Mpx, 2.2 Mpx and 4.1 Mpx, b/w, color and NIR extended
- Frame rates up to 210 fps

1.2 Advantages

Industry standard interface	compliant with USB 3.0 SuperSpeed specification
AIA standard compatibility	USB 3 Vision standard
Small	fits into places where no other camera can fit
Low power consumption	1.0 to 1.8 W
Powerful	5 Gbit/s interface up to 450 Mpx/s data throughput
Fast	high speed, high frame rate: > 210 fps at 1.3 Mpx and 90 fps at 4 Mpx resolutions
Robust	full metal housing, no sheet metal covers
Lightweight	facilitates increased performance of robotic arms and gimbals
Connectivity	programmable opto-isolated input and output, 3 status LEDs
Compatibility	support for Windows, Linux and MacOS, ARM, various Image Processing Libraries
Software interfaces	GenICam / GenTL and highly optimized xiAPI SDK
Economical	excellent value and price, low TCO and fast ROI

1.3 Camera applications

- Automation
- Ultra-fast 3D scanning
- Miniature and fast robotic arms
- Mobile devices
- In-situ optical inspection camera
- Material and life science microscopy
- Ophthalmology and retinal imaging
- Broadcasting
- Fast process capture, e.g. golf club swings
- Intelligent Transportations Systems (ITS) and traffic monitoring
- UAV

1.4 Common features

Sensor Technology	CMOS, Global shutter
Acquisition Modes	continuous, software and hardware trigger, defined fps, exposure defined by trigger pulse and burst
Partial Image Readout	ROI, Skipping and Binning modes supported (model specific)
Image data formats	8, 10 or 12 bit RAW pixel data ¹
Color image processing	host based de-bayering, sharpening, gamma, color matrix, true color CMS
Hot/blemish pixels correction	on camera storage of up to 5000 px coordinates, host assisted correction
Auto adjustments	auto white balance, auto gain, auto exposure
Flat field corrections	host assisted pixel level shading and lens corrections
Image Data and Control Interface	USB 3.0 standard micro B with screw lock threads compliant to USB 3 Vision standard
General Purpose I/O	1x opto-isolated input, 1x opto-isolated output, power LED, 3x LED software programmable
Signal conditioning	programmable debouncing time
Synchronization	hardware trigger input, software trigger, exposure strobe output, busy output
Housing and lens mount	standard C-mount, available options are CS mount, and board level
Power requirements	1 to 1.8 W, supplied via USB 3.0 interface, supplied via USB 3.0 interface
Environment	operating 0 to 50 °C on housing, RH 80 % non-condensing, -25 to 60 °C storage
Operating systems	Windows, Linux Ubuntu, MacOS
Software support	xiAPI SDK, adapters and drivers for various image processing packages
Firmware updates	field firmware updatable

¹Maximal image data precision depends on sensor ADC precision

1.5 Model nomenclature

xiQ MQxxxT-zz-S7[-OPT]

MQ = xiQ family name

xxx = Resolution

xxx: resolution in 0.1 Mpx, (e.g. 1.3 Mpx: xxx = 013)

y = Color sensing

C: color model

M: black & white model

R: black & white, Infrared-extended model

T = Sensor technology

G: Global shutter (all xiQ cameras are global shutter)

zz = Vendor of the sensor

E2: E2V

CM: CMOSIS

ON: Onsemi (Current xiQ models produced utilize a newer FPGA indicated by the S7 in the part number.)

[-OPT] = Connector options

TG: sensor with taped sensor glass

BRD: board level camera

FL / FV: camera featuring flex cable connector (only specific models), please contact sales for more information

NIO: models without IO connector

Aegis Electronic Group
www.aegiselect.com

1.6 Models and sensors overview

Camera model	Sensor model	Sensor type	Filter	Resolution [px]	Pixel size [μm]
MQ013CG-E2-S7	e2v EV76C560	Color	BayerRG	1280 × 1024	5.3
MQ013MG-E2-S7	e2v EV76C560	Monochrome	None	1280 × 1024	5.3
MQ013RG-E2-S7	e2v EV76C661	Monochrome-NIR	None	1280 × 1024	5.3
MQ013MG-E2-S7-FV	e2v EV76C560	Monochrome	None	1280 × 1024	5.3
MQ013CG-E2-S7-NIO	e2v EV76C560	Color	BayerRG	1280 × 1024	5.3
MQ013CG-ON-S7	OnSemi PYTHON1300	Color	BayerRG	1280 × 1024	4.8
MQ013MG-ON-S7	OnSemi PYTHON1300	Monochrome	None	1280 × 1024	4.8
MQ013RG-ON-S7	OnSemi PYTHON1300	Monochrome-NIR	None	1280 × 1024	4.8
MQ013CG-E2-S7-FL	e2v EV76C560	Color	BayerRG	1280 × 1024	5.3
MQ013CG-E2-S7-FV	e2v EV76C560	Color	BayerRG	1280 × 1024	5.3
MQ013RG-E2-S7-FL	e2v EV76C661	Monochrome-NIR	None	1280 × 1024	5.3
MQ013RG-E2-S7-FV	e2v EV76C661	Monochrome-NIR	None	1280 × 1024	5.3
MQ013MG-E2-S7-FL	e2v EV76C560	Monochrome	None	1280 × 1024	5.3
MQ013MG-E2-S7-NIO	e2v EV76C560	Monochrome	None	1280 × 1024	5.3
MQ013RG-E2-S7-NIO	e2v EV76C661	Monochrome-NIR	None	1280 × 1024	5.3
MQ022RG-CM-S7	CMOSIS CMV2000	Monochrome-NIR	None	2048 × 1088	5.5
MQ022CG-CM-S7	CMOSIS CMV2000	Color	BayerGB	2048 × 1088	5.5
MQ022MG-CM-S7	CMOSIS CMV2000	Monochrome	None	2048 × 1088	5.5
MQ022CG-CM-S7-FL	CMOSIS CMV2000	Color	BayerGB	2048 × 1088	5.5
MQ022RG-CM-S7-FL	CMOSIS CMV2000	Monochrome-NIR	None	2048 × 1088	5.5
MQ022MG-CM-S7-FL	CMOSIS CMV2000	Monochrome	None	2048 × 1088	5.5
MQ042CG-CM-S7	CMOSIS CMV4000	Color	BayerGB	2048 × 2048	5.5
MQ042RG-CM-S7	CMOSIS CMV4000	Monochrome-NIR	None	2048 × 2048	5.5
MQ042MG-CM-S7	CMOSIS CMV4000	Monochrome	None	2048 × 2048	5.5
MQ042CG-CM-S7-FL	CMOSIS CMV4000	Color	BayerGB	2048 × 2048	5.5
MQ042MG-CM-S7-FL	CMOSIS CMV4000	Monochrome	None	2048 × 2048	5.5
MQ042MG-CM-S7-NIO	CMOSIS CMV4000	Monochrome	None	2048 × 2048	5.5

Table 1: List of camera models and their respective sensor models and filters

1.7 Accessories overview

The following accessories are available:

Item P/N	Description
CBL-U3-3M0	3.0 m USB 3.0 cable, micro B connector
CBL-U3-3M0-ANG	3.0 m USB 3.0 cable, angled micro B USB3 connector
CBL-U3-5M0	5.0 m USB 3.0 cable, micro B connector
CBL-MQ-FL-0M1	Cable FPC MQ/MC Flex-Line, 0.1 m (gold color)
CBL-MQ-FL-0M25	Cable FPC MQ/MC Flex-Line, 0.25 m (gold color)
CBL-USB3FLEX-0M10	Cable FPC MQ/MC Flex-Line, 0.1 m (white color)
CBL-USB3FLEX-0M25	Cable FPC MQ/MC Flex-Line, 0.25 m (white color)
CBL-USB3FLEX-0M50	Cable FPC MQ/MC Flex-Line, 0.5 m (white color)
BOB-MQ-FL	Break Out Board, Flex-Line, Simple Board Level Micro-B USB3.0
MQ-BRACKET-T	xiQ series tripod mounting bracket, 5.5 mm thick
MQ-BRACKET-T-THICK	xiQ series tripod mounting bracket, 9.5 mm thick
U3PE-FL1100-X41	PCI express adapter, 4x USB 3.0 ports, PCIe x4 slot ¹
CBL-S-M5-3P-PT-5M0	IO pigtail cable 5 m long unshielded ²
CBL-S-M5-3P-PT-5M0-S	IO pigtail cable 5 m long shielded ²
CBL-S-PB3-PT-0M30	IO pigtail cable 5 m long shielded ²

¹For more information please visit website: [USB 3 Host Adapters](#)

²These trigger cables are for the newer S7 camera variants

Table 2: list of accessories available for xiC cameras

2 Hardware specification

2.1 Power supply

The power consumption table can consist of several values:

- Supply voltage:** Voltage used for measuring the power consumption.
- Idle:** The average power consumption when the camera is powered, but not opened/initialized in software.
- Typical:** The average power consumption during streaming in the most power-intensive mode, (typically the one with the highest frame rate).
- Maximum:** The highest power consumption peak recorded during streaming in the most power-intensive mode, (measured using a current probe).

Power consumption of:

MQ013CG-E2-S7	MQ013MG-E2-S7	MQ013RG-E2-S7
MQ013CG-E2-S7-FL	MQ013CG-E2-S7-FV	MQ013MG-E2-S7-FV
MQ013RG-E2-S7-FL	MQ013RG-E2-S7-FV	MQ013MG-E2-S7-FL
MQ013MG-E2-S7-NIO	MQ013CG-E2-S7-NIO	

Supply Voltage ¹	Consumption idle	Consumption typical	Consumption maximum
5 V	0.68 W	0.98 W	1.05 W

¹Supported voltage 4.5 - 5.5 V

Table 3: Power consumption of the specific models

Power consumption of:

MQ013CG-ON-S7	MQ013MG-ON-S7
---------------	---------------

Supply Voltage ¹	Consumption idle	Consumption typical	Consumption maximum
5 V	0.8 W	1.58 W	1.65 W

¹Supported voltage 4.5 - 5.5 V

Table 4: Power consumption of the specific models

Power consumption of:

MQ022RG-CM-S7	MQ022CG-CM-S7	MQ022MG-CM-S7
MQ022CG-CM-S7-FL	MQ022RG-CM-S7-FL	MQ022MG-CM-S7-FL
MQ042CG-CM-S7	MQ042RG-CM-S7	MQ042MG-CM-S7
MQ042CG-CM-S7-FL	MQ042MG-CM-S7-FL	

Supply Voltage ¹	Consumption idle	Consumption typical	Consumption maximum
5 V	1.3 W	1.55 W	1.65 W

¹Supported voltage 4.5 - 5.5 V

Table 5: Power consumption of the specific models

2.1.1 Power input

The xiQ-S7 cameras are powered via the USB 3.1 Micro-B connector or the flex line connector. The USB 3.1 cable that you use with the camera is responsible for the power supply and the data transfer to the PC. The input voltage is 5 V DC. Power consumption depends on

the camera model. We recommend using XIMEA industrial USB 3.1 cables to achieve the maximum possible performance of the camera. XIMEA offers several passive USB 3.1 cables and a sync cables, please see [CBL-U3-xM](#), [CBL-U3-3M0-ANG](#) and [CBL-MQ-FL-xM](#).

Aegis Electronic Group
www.aegiselect.com

2.2 General specification

2.2.1 Environment

Description	Symbol	Value
Optimal ambient temperature operation	T_{opt}	10 to 25 °C
Ambient temperature operation	T_{max}	0 to 50 °C
Ambient temperature for storage and transportation	$T_{storage}$	-25 to 60 °C
Relative Humidity, non-condensing	RH	80 %

Table 6: Environment

Housing temperature must not exceed 65 °C.

Note: The following parameters are not guaranteed if the cameras are operated outside the optimum range:

- Dark current
- Dynamic Range
- Linearity
- Acquisition
- Readout noise
- S/N ratio
- Durability

Aegis Electronic Group
www.aegiselect.com

2.3 Lens mount

2.3.1 C/CS-mount

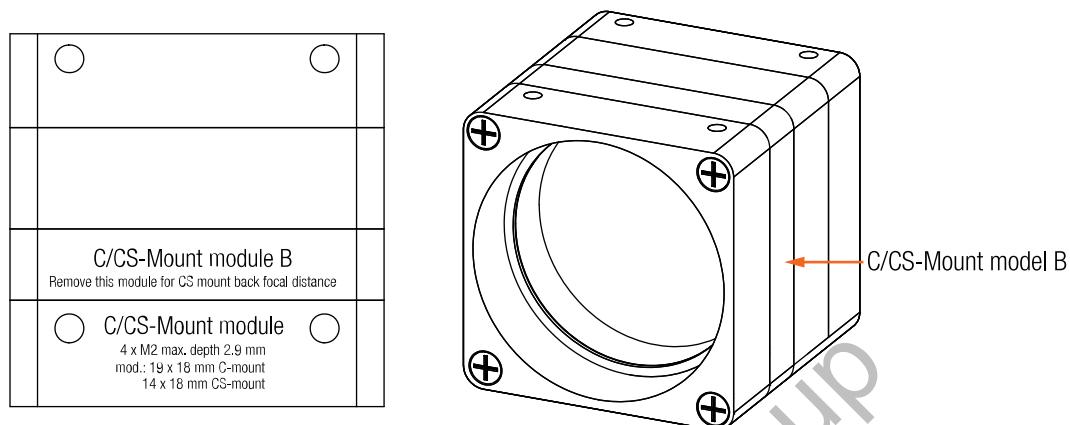

Figure 6: Lens mount adapter C/CS-mount

The cameras are initially equipped with a C-mount back focal length. Through the removal of the “C/CS-Mount module B”, the camera can be transformed for CS-mount compatibility, effectively reducing the back focal distance and overall length of the camera by 5 mm. The required M2x8 mm special screws for this conversion are included in the camera delivery. The length of the lens thread measured at 6.5 mm. For detailed instructions, please refer to section [Optical path](#)

Conversion between these two options is described here: [Convert C to CS Mount](#)

Lens mount adapter configuration:

- C-Mount (with C/CS Mount module B)
- CS-Mount (without C/CS Mount module B)

The mentioned lens adapter is included in:
all models in this manual (refer to the table [Models and sensors overview](#))

2.4 Mounting points

The mounting points available to the customer are shown below. Use only the designated threaded holes for mounting the camera. Utilize only the specified screws and torques when fastening. Never exceed the maximum torque when fastening the mounting screws.

Specific mounting information can be found in the dimensional drawings of the camera models located in section [Dimensional drawings](#).

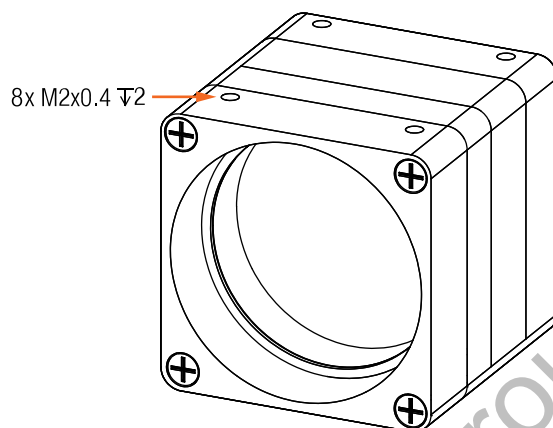

Figure 7: xiC camera mounting points

2.4.1 Screws

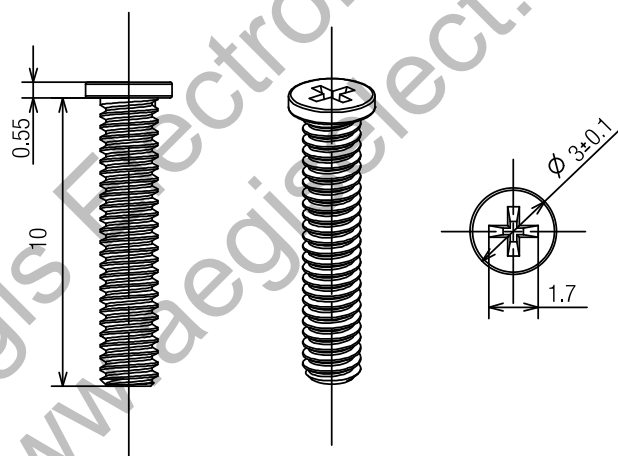

Figure 8: M2 mounting screws

Item	Value
Material	Steel
Surface	Black zinc
Thread	M2
Driver	PH 00
Avail. lengths	3 to 24 mm

Table 7: M2 screw description

2.5 Optical path

The optical path in cameras defines the course traversed by light from the observed object to the image captured by the sensor. It involves complex interactions with components (e.g. lenses).

The flange focal distance (FFD) or optical distance is the distance between a lens's mounting flange and a camera's sensor plane. In standard setups, it assumes that only air fills the space between the lens and the sensor. However, the introduction of additional elements like windows or filters can alter the focal plane through refraction, requiring an adjusted FFD for proper alignment.

The presence or absence of a filter or sensor window in the camera depends on the camera model. The distance from the flange to the sensor is designed (refer to the camera cross-section image below for visual information).

Do not use compressed air to clean the camera as this could push dust particles into the camera or potentially cause damage (e.g. scratches).

Cross-section corresponding to:

MQ013CG-E2-S7

MQ013CG-E2-S7-FL

MQ013RG-E2-S7-FL

MQ013MG-E2-S7-NIO

MQ013MG-E2-S7

MQ013CG-E2-S7-FV

MQ013RG-E2-S7-FV

MQ013CG-E2-S7-NIO

MQ013RG-E2-S7

MQ013MG-E2-S7-FV

MQ013MG-E2-S7-FL

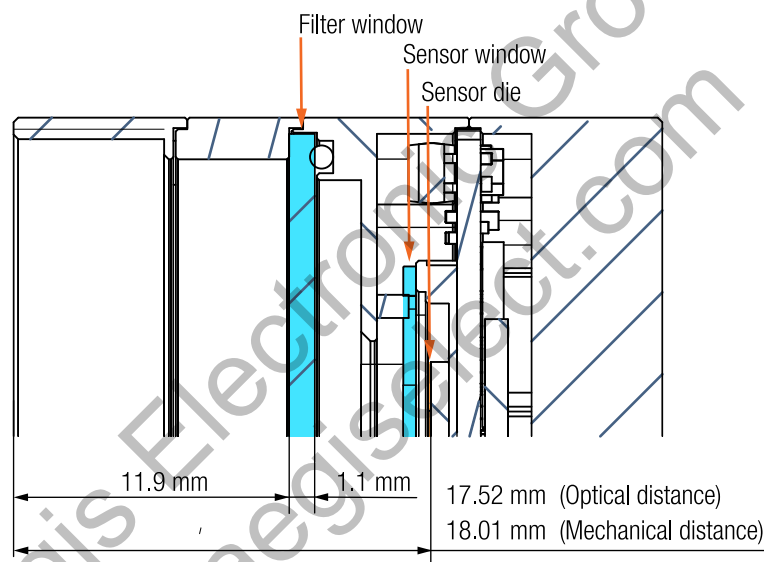

Figure 9: Cross section of MQ013xG-E2-S7 camera models

Cross-section corresponding to:
MQ013CG-ON-S7

MQ013MG-ON-S7

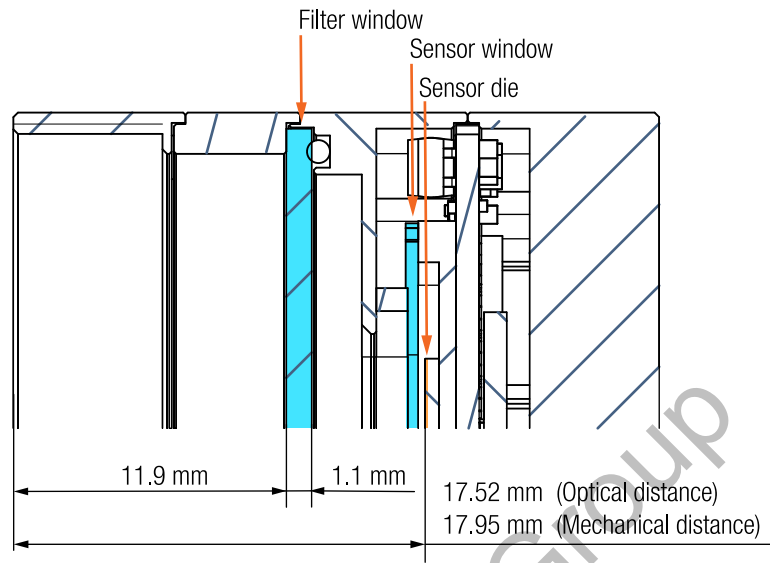

Figure 10: Cross section of MQ013xG-ON-S7 camera models

Cross-section corresponding to:
MQ022RG-CM-S7
MQ022CG-CM-S7-FL
MQ042CG-CM-S7
MQ042CG-CM-S7-FL

MQ022CG-CM-S7
MQ022RG-CM-S7-FL
MQ042RG-CM-S7
MQ042MG-CM-S7-FL

MQ022MG-CM-S7
MQ022MG-CM-S7-FL
MQ042MG-CM-S7

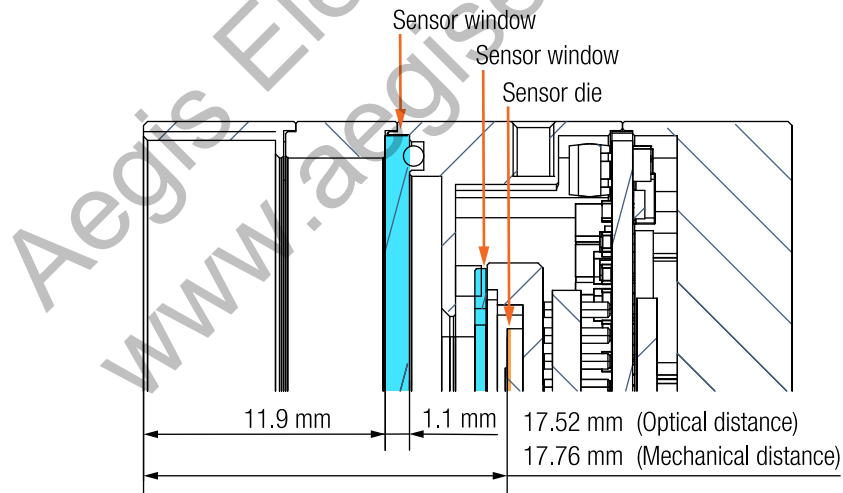

Figure 11: Cross section of MQ022/042xG-CM-S7 camera models

The following filter window is implemented in:

- | | | |
|-------------------|-------------------|------------------|
| MQ013MG-E2-S7 | MQ013RG-E2-S7 | MQ013MG-E2-S7-FV |
| MQ013RG-E2-S7-FL | MQ013RG-E2-S7-FV | MQ013MG-E2-S7-FL |
| MQ013MG-E2-S7-NIO | MQ013RG-E2-S7-NIO | MQ013MG-ON-S7 |
| MQ013RG-ON-S7 | MQ022RG-CM-S7 | MQ022MG-CM-S7 |
| MQ022RG-CM-S7-FL | MQ022MG-CM-S7-FL | MQ042RG-CM-S7 |
| MQ042MG-CM-S7 | MQ042MG-CM-S7-FL | |

Filter	Coating	Thickness
Filter BK7	ARx2	1.1 mm

Table 8: BK7 filter window parameter

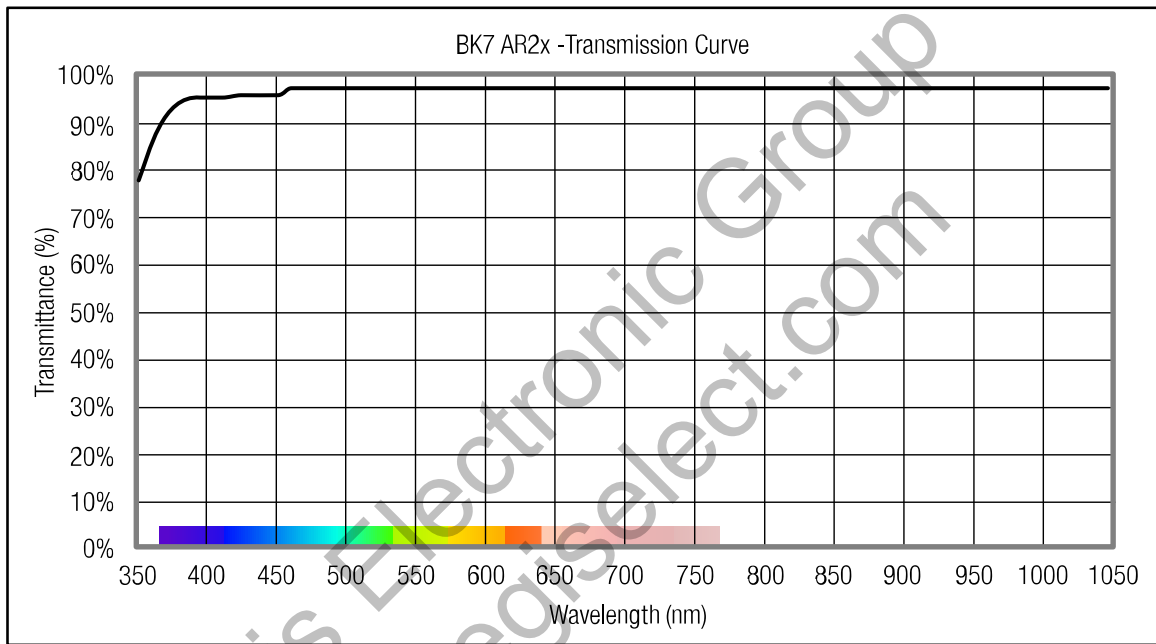

Figure 12: Filter glass BK7 AR2x Transmission Curve

The following filter window is implemented in:

MQ013CG-E2-S7

MQ013CG-ON-S7

MQ022CG-CM-S7-FL

MQ013CG-E2-S7-FV

MQ013CG-E2-S7-FL

MQ042CG-CM-S7

MQ013CG-E2-S7-NIO

MQ022CG-CM-S7

Filter	Coating	Thickness
IR Filter IR650	ARx2	1.1 mm

Table 9: IR650 filter window parameter

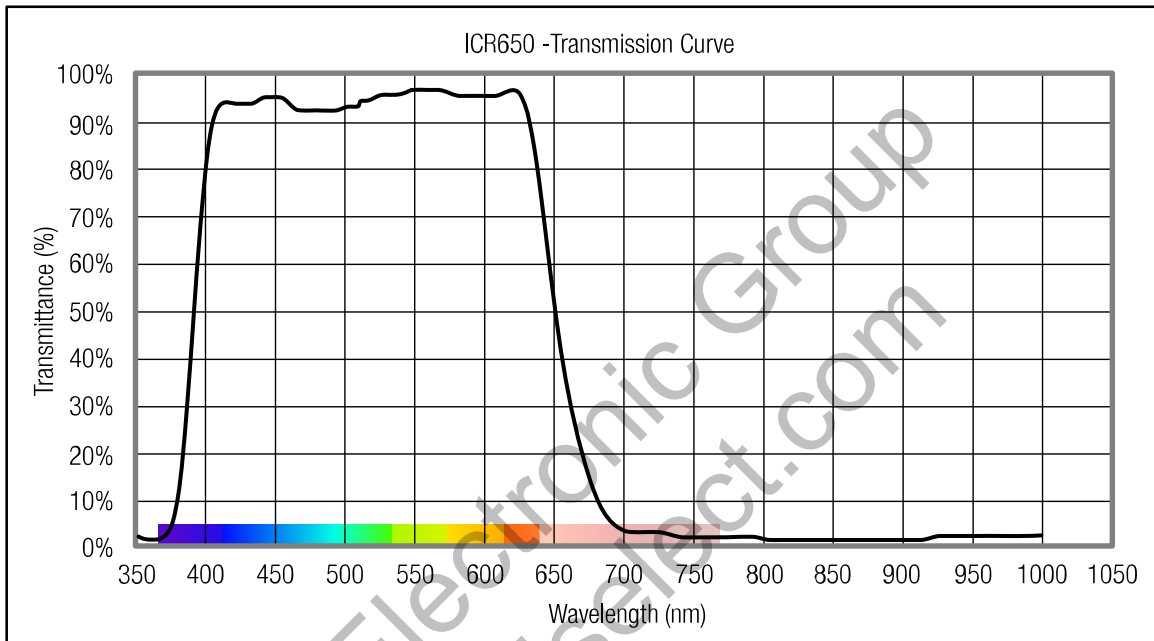

Figure 13: Filter glass ICR650 Transmission Curve

2.6 Sensor and camera characteristics

2.6.1 Sensor and camera parameters

Sensor parameters of:

MQ013CG-E2-S7
 MQ013CG-E2-S7-FL
 MQ013RG-E2-S7-FL
 MQ013MG-E2-S7-NIO

MQ013MG-E2-S7
 MQ013CG-E2-S7-FV
 MQ013RG-E2-S7-FV
 MQ013CG-E2-S7-NIO

MQ013RG-E2-S7
 MQ013MG-E2-S7-FV
 MQ013MG-E2-S7-FL

Description	Value	Unit
Technology	CMOS	None
Pixel resolution (H x V)	1280 x 1024	[px]
Active area size (H X V)	6.9 x 5.5	[mm]
Sensor diagonal	8.7	[mm]
Pixel size (H x V)	5.3 x 5.3	[µm]

Table 10: Sensor parameters of the specific models

Sensor parameters of:

MQ013CG-ON-S7

MQ013MG-ON-S7

Description	Value	Unit
Technology	CMOS	None
Pixel resolution (H x V)	1280 x 1024	[px]
Active area size (H X V)	6.18 x 4.95	[mm]
Sensor diagonal	7.9	[mm]
Pixel size (H x V)	4.8 x 4.8	[µm]

Table 11: Sensor parameters of the specific models

Sensor parameters of:

MQ022RG-CM-S7
 MQ022CG-CM-S7-FL

MQ022CG-CM-S7
 MQ022RG-CM-S7-FL

MQ022MG-CM-S7

Description	Value	Unit
Technology	CMOS	None
Pixel resolution (H x V)	2048 x 1088	[px]
Active area size (H X V)	11.27 x 6	[mm]
Sensor diagonal	12.8	[mm]
Pixel size (H x V)	5.5 x 5.5	[µm]

Table 12: Sensor parameters of the specific models

Sensor parameters of:
 MQ042CG-CM-S7
 MQ042CG-CM-S7-FL

MQ042RG-CM-S7
 MQ042MG-CM-S7-FL

MQ042MG-CM-S7

Description	Value	Unit
Technology	CMOS	None
Pixel resolution (H x V)	2048 x 2048	[px]
Active area size (H X V)	11.27 x 11.27	[mm]
Sensor diagonal	15.9	[mm]
Pixel size (H x V)	5.5 x 5.5	[μm]

Table 13: Sensor parameters of the specific models

Aegis Electronic Group
 www.aegiselect.com

2.6.2 Image quality parameters

The image quality parameters listed below represent typical values for these camera models. Minor variations may occur between different units of the same model.

Image quality parameters of:
MQ013CG-E2-S7
MQ013CG-E2-S7-NIO

MQ013CG-E2-S7-FL

MQ013CG-E2-S7-FV

Mode		10 bit
Sensor bit/px	[bit/px]	10
Parameters		
Temporal dark noise	[e.]	27.7
Absolute sensitivity threshold	[e.]	28.2
Saturation capacity	[ke.]	10.82
Dynamic range	[dB]	51.65
MAX Signal-to-noise ratio	[dB]	40.46
Overall system gain	[e./DN]	11.28
Dark current	[e./s]	1347.29
Dark current meas. temp.	[°C]	39.9
DSNU	[e.]	33.75
PRNU	[%]	1.86
Linearity error	[%]	3.77

Table 14: Image quality parameters of the specific models

Image quality parameters of:
MQ013MG-E2-S7
MQ013MG-E2-S7-NIO

MQ013MG-E2-S7-FV

MQ013MG-E2-S7-FL

Mode		10 bit
Sensor bit/px	[bit/px]	10
Parameters		
Temporal dark noise	[e.]	27.65
Absolute sensitivity threshold	[e.]	28.15
Saturation capacity	[ke.]	10.92
Dynamic range	[dB]	51.76
MAX Signal-to-noise ratio	[dB]	40.41
Overall system gain	[e./DN]	11.31
Dark current	[e./s]	1096.42
Dark current meas. temp.	[°C]	40.2
DSNU	[e.]	34.66
PRNU	[%]	1.39
Linearity error	[%]	4.77

Table 15: Image quality parameters of the specific models

Image quality parameters of:
MQ013RG-E2-S7
MQ013RG-E2-S7-NIO

MQ013RG-E2-S7-FL

MQ013RG-E2-S7-FV

Mode		10 bit
Sensor bit/px	[bit/px]	10
Parameters		
Temporal dark noise	[e.]	23.71
Absolute sensitivity threshold	[e.]	24.21
Saturation capacity	[ke.]	7.89
Dynamic range	[dB]	50.23
MAX Signal-to-noise ratio	[dB]	38.81
Overall system gain	[e./DN]	8.26
Dark current	[e./s]	789.44
Dark current meas. temp.	[°C]	39.7
DSNU	[e.]	23.13
PRNU	[%]	1.38
Linearity error	[%]	2.18

Table 16: Image quality parameters of the specific models

Image quality parameters of:
MQ013CG-ON-S7

Mode		10 bit
Sensor bit/px	[bit/px]	10
Parameters		
Temporal dark noise	[e.]	8.99
Absolute sensitivity threshold	[e.]	9.49
Saturation capacity	[ke.]	7.82
Dynamic range	[dB]	58.38
MAX Signal-to-noise ratio	[dB]	39.09
Overall system gain	[e./DN]	9.11
Dark current	[e./s]	790.76
Dark current meas. temp.	[°C]	49.9
DSNU	[e.]	5.09
PRNU	[%]	0.95
Linearity error	[%]	1.79

Table 17: Image quality parameters of the specific models

Image quality parameters of:
MQ013MG-ON-S7

Mode		10 bit
Sensor bit/px	[bit/px]	10
Parameters		
Temporal dark noise	[e.]	9.37
Absolute sensitivity threshold	[e.]	9.87
Saturation capacity	[ke.]	7.35
Dynamic range	[dB]	57.42
MAX Signal-to-noise ratio	[dB]	38.86
Overall system gain	[e./DN]	8.85
Dark current	[e./s]	756.84
Dark current meas. temp.	[°C]	49.6
DSNU	[e.]	5.53
PRNU	[%]	0.88
Linearity error	[%]	2.43

Table 18: Image quality parameters of the specific models

Image quality parameters of:
MQ013RG-ON-S7

Mode		10 bit
Sensor bit/px	[bit/px]	10
Parameters		
Temporal dark noise	[e.]	9.07
Absolute sensitivity threshold	[e.]	9.57
Saturation capacity	[ke.]	7.87
Dynamic range	[dB]	58.21
MAX Signal-to-noise ratio	[dB]	39.38
Overall system gain	[e./DN]	9.18
Dark current	[e./s]	778.76
Dark current meas. temp.	[°C]	49.6
DSNU	[e.]	5.09
PRNU	[%]	1.17
Linearity error	[%]	2.35

Table 19: Image quality parameters of the specific models

Image quality parameters of:
MQ022CG-CM-S7

MQ022CG-CM-S7-FL

Mode		10 bit
Sensor bit/px	[bit/px]	10
Parameters		
Temporal dark noise	[e.]	15.96
Absolute sensitivity threshold	[e.]	16.46
Saturation capacity	[ke.]	8.67
Dynamic range	[dB]	54.49
MAX Signal-to-noise ratio	[dB]	39.21
Overall system gain	[e./DN]	9.88
Dark current	[e./s]	2215.37
Dark current meas. temp.	[°C]	49.4
DSNU	[e.]	19.98
PRNU	[%]	1.52
Linearity error	[%]	0.88

Table 20: Image quality parameters of the specific models

Image quality parameters of:
MQ022RG-CM-S7

MQ022RG-CM-S7-FL

Mode		10 bit
Sensor bit/px	[bit/px]	10
Parameters		
Temporal dark noise	[e.]	15.68
Absolute sensitivity threshold	[e.]	16.18
Saturation capacity	[ke.]	7.47
Dynamic range	[dB]	53.38
MAX Signal-to-noise ratio	[dB]	38.06
Overall system gain	[e./DN]	8.96
Dark current	[e./s]	2058.65
Dark current meas. temp.	[°C]	49.4
DSNU	[e.]	18.62
PRNU	[%]	1.43
Linearity error	[%]	0.7

Table 21: Image quality parameters of the specific models

Image quality parameters of:
MQ022MG-CM-S7

MQ022MG-CM-S7-FL

Mode		10 bit
Sensor bit/px	[bit/px]	10
Parameters		
Temporal dark noise	[<i>e.</i>]	15.83
Absolute sensitivity threshold	[<i>e.</i>]	16.33
Saturation capacity	[<i>ke.</i>]	8.86
Dynamic range	[dB]	54.79
MAX Signal-to-noise ratio	[dB]	39.56
Overall system gain	[<i>e./DN</i>]	9.45
Dark current	[<i>e./s</i>]	1975.2
Dark current meas. temp.	[°C]	49.1
DSNU	[<i>e.</i>]	19.01
PRNU	[%]	1.24
Linearity error	[%]	0.65

Table 22: Image quality parameters of the specific models

Image quality parameters of:
MQ042RG-CM-S7

Mode		10 bit
Sensor bit/px	[bit/px]	10
Parameters		
Temporal dark noise	[<i>e.</i>]	15.53
Absolute sensitivity threshold	[<i>e.</i>]	16.03
Saturation capacity	[<i>ke.</i>]	7.1
Dynamic range	[dB]	53.02
MAX Signal-to-noise ratio	[dB]	37.83
Overall system gain	[<i>e./DN</i>]	8.54
Dark current	[<i>e./s</i>]	1598.79
Dark current meas. temp.	[°C]	49.1
DSNU	[<i>e.</i>]	20.88
PRNU	[%]	1.37
Linearity error	[%]	1.76

Table 23: Image quality parameters of the specific models

Image quality parameters of:
MQ042CG-CM-S7

MQ042CG-CM-S7-FL

Mode		10 bit
Sensor bit/px	[bit/px]	10
Parameters		
Temporal dark noise	[e.]	16.15
Absolute sensitivity threshold	[e.]	16.65
Saturation capacity	[ke.]	7.56
Dynamic range	[dB]	53.07
MAX Signal-to-noise ratio	[dB]	38.36
Overall system gain	[e./DN]	8.92
Dark current	[e./s]	1741.6
Dark current meas. temp.	[°C]	49.1
DSNU	[e.]	21.67
PRNU	[%]	1.49
Linearity error	[%]	1.32

Table 24: Image quality parameters of the specific models

Image quality parameters of:
MQ042MG-CM-S7

MQ042MG-CM-S7-FL

Mode		10 bit
Sensor bit/px	[bit/px]	10
Parameters		
Temporal dark noise	[e.]	15.82
Absolute sensitivity threshold	[e.]	16.32
Saturation capacity	[ke.]	8.24
Dynamic range	[dB]	54.29
MAX Signal-to-noise ratio	[dB]	39.21
Overall system gain	[e./DN]	9.04
Dark current	[e./s]	1773.28
Dark current meas. temp.	[°C]	49.3
DSNU	[e.]	22.43
PRNU	[%]	1.38
Linearity error	[%]	1.12

Table 25: Image quality parameters of the specific models

2.6.3 Sensor read-out modes

Sensor Read-out modes of:

MQ013CG-E2-S7

MQ013CG-E2-S7-FL

MQ013RG-E2-S7-FL

MQ013MG-E2-S7-NIO

MQ013MG-E2-S7

MQ013CG-E2-S7-FV

MQ013RG-E2-S7-FV

MQ013CG-E2-S7-NIO

MQ013RG-E2-S7

MQ013MG-E2-S7-FV

MQ013MG-E2-S7-FL

Downsampling (H x V)	Sensor bit/px	Resolution (W x H)	Transport bit/px	Maximum frame rate ¹
1 x 1	10	1280 x 1024	8	61.6
1 x 1	10	1280 x 1024	10	61.6
1 x 1	10	1280 x 1024	12	61.6
Bin.2 x 2	10	640 x 512	8	61.6
Bin.2 x 2	10	640 x 512	10	61.6
Bin.2 x 2	10	640 x 512	12	61.6

¹Maximum frame rate was measured using the transport format at maximum bandwidth 380.0 MB/s

Table 26: Sensor read-out modes of the specific models

Sensor Read-out modes of:

MQ013CG-ON-S7

MQ013MG-ON-S7

Downsampling (H x V)	Zero ROT	Sensor bit/px	Resolution (W x H)	Transport bit/px	Maximum frame rate ¹
1 x 1	-	10	1280 x 1024	8	172.2
1 x 1	-	10	1280 x 1024	10	172.2
1 x 1	-	10	1280 x 1024	12	141.1
Dec.2 x 2	-	10	640 x 512	8	554.0
Dec.2 x 2	-	10	640 x 512	10	554.0
Dec.2 x 2	-	10	640 x 512	12	541.6
1 x 1	On	10	1280 x 1024	8	210.5
1 x 1	On	10	1280 x 1024	10	210.5
1 x 1	On	10	1280 x 1024	12	140.8
Dec.2 x 2	On	10	640 x 512	8	789.9
Dec.2 x 2	On	10	640 x 512	10	789.9
Dec.2 x 2	On	10	640 x 512	12	538.5

¹Maximum frame rate was measured using the transport format at maximum bandwidth 380.0 MB/s

Table 27: Sensor read-out modes of the specific models

Sensor Read-out modes of:

MQ022RG-CM-S7

MQ022CG-CM-S7

MQ022MG-CM-S7

MQ022CG-CM-S7-FL

MQ022RG-CM-S7-FL

Downsampling (H x V)	Sensor bit/px	Resolution (W x H)	Transport bit/px	Maximum frame rate ¹
1 x 1	10	2048 x 1088	8	169.9
1 x 1	10	2048 x 1088	10	134.5
1 x 1	10	2048 x 1088	12	85.0

¹Maximum frame rate was measured using the transport format at maximum bandwidth 380.0 MB/s

Table 28: Sensor read-out modes of the specific models

Sensor Read-out modes of:

MQ042CG-CM-S7

MQ042RG-CM-S7

MQ042MG-CM-S7

MQ042CG-CM-S7-FL

MQ042MG-CM-S7-FL

Downsampling (H x V)	Sensor bit/px	Resolution (W x H)	Transport bit/px	Maximum frame rate ¹
1 x 1	10	2048 x 2048	8	90.3
1 x 1	10	2048 x 2048	10	71.5
1 x 1	10	2048 x 2048	12	45.2

¹Maximum frame rate was measured using the transport format at maximum bandwidth 380.0 MB/s

Table 29: Sensor read-out modes of the specific models

2.6.4 Quantum efficiency curves

Quantum efficiency curves for:

MQ013CG-E2-S7

MQ013CG-E2-S7-FV

MQ013MG-E2-S7-NIO

MQ013MG-E2-S7

MQ013MG-E2-S7-FV

MQ013CG-E2-S7-NIO

MQ013CG-E2-S7-FL

MQ013MG-E2-S7-FL

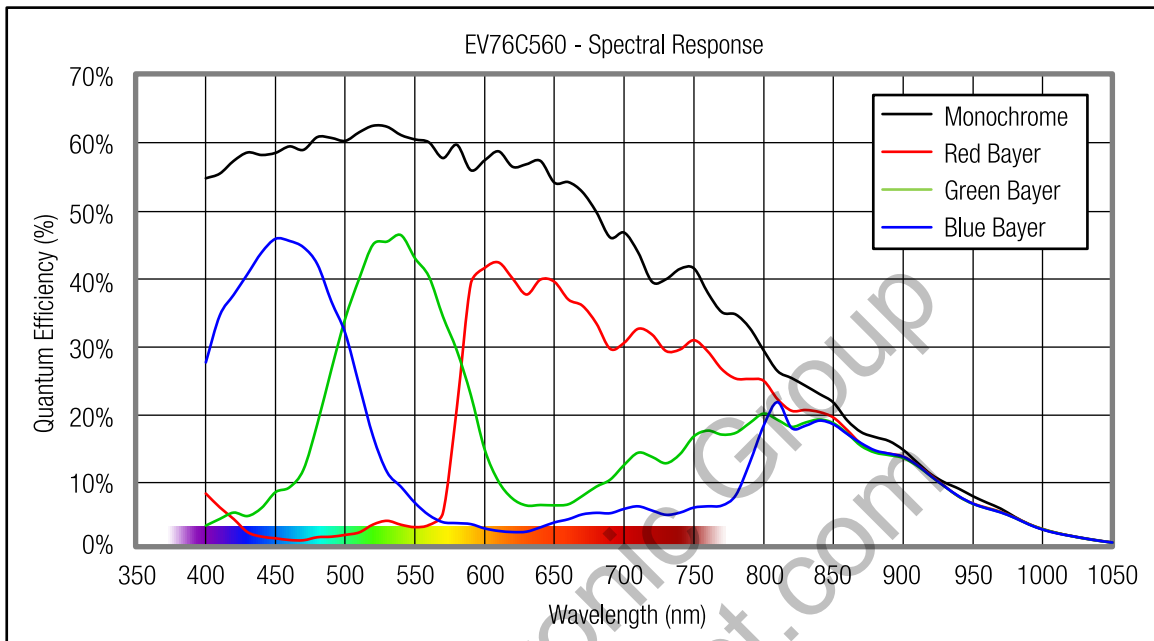

Figure 14: Graph quantum efficiency of E2V EV76C560

Quantum efficiency curves for:

MQ013RG-E2-S7

MQ013RG-E2-S7-NIO

MQ013RG-E2-S7-FL

MQ013RG-E2-S7-FV

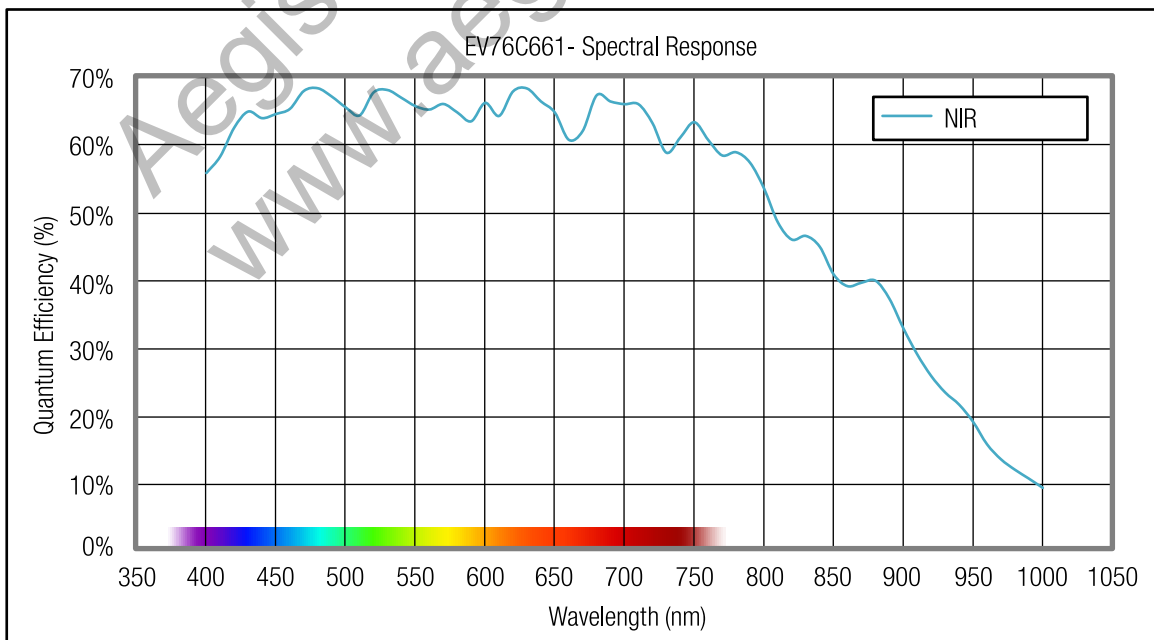

Figure 15: Graph quantum efficiency of E2V EV76C661

Quantum efficiency curves for:
MQ013CG-ON-S7

MQ013MG-ON-S7

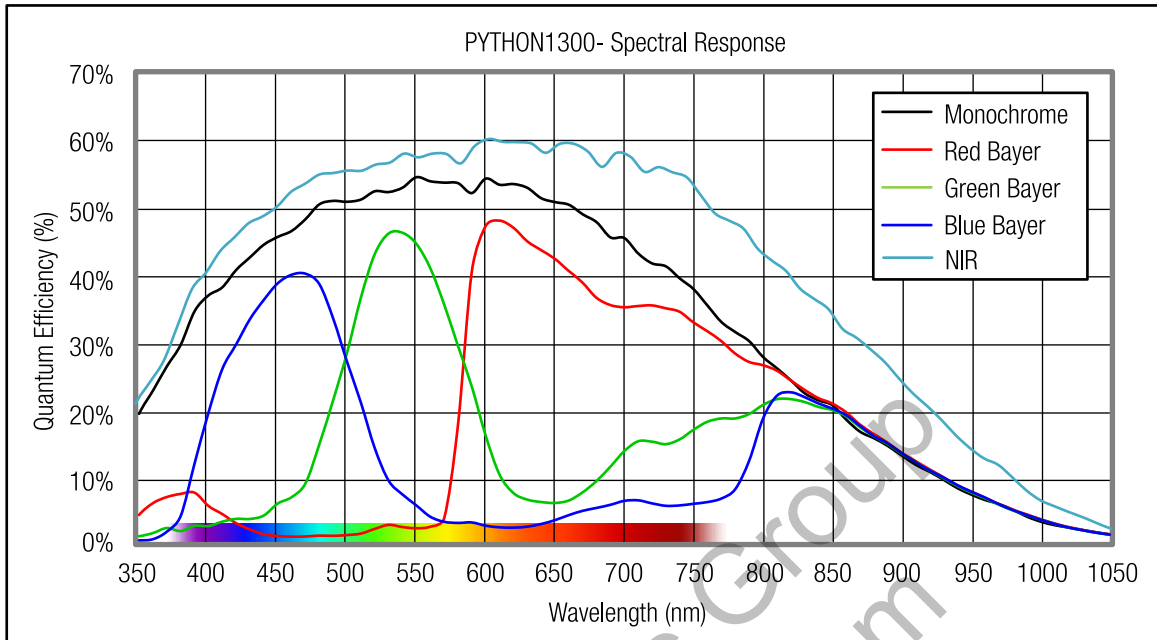

Figure 16: Graph quantum efficiency of OnSemi PYTHON1300

Quantum efficiency curves for:
MQ022RG-CM-S7
MQ022CG-CM-S7-FL

MQ022CG-CM-S7
MQ022RG-CM-S7-FL

MQ022MG-CM-S7

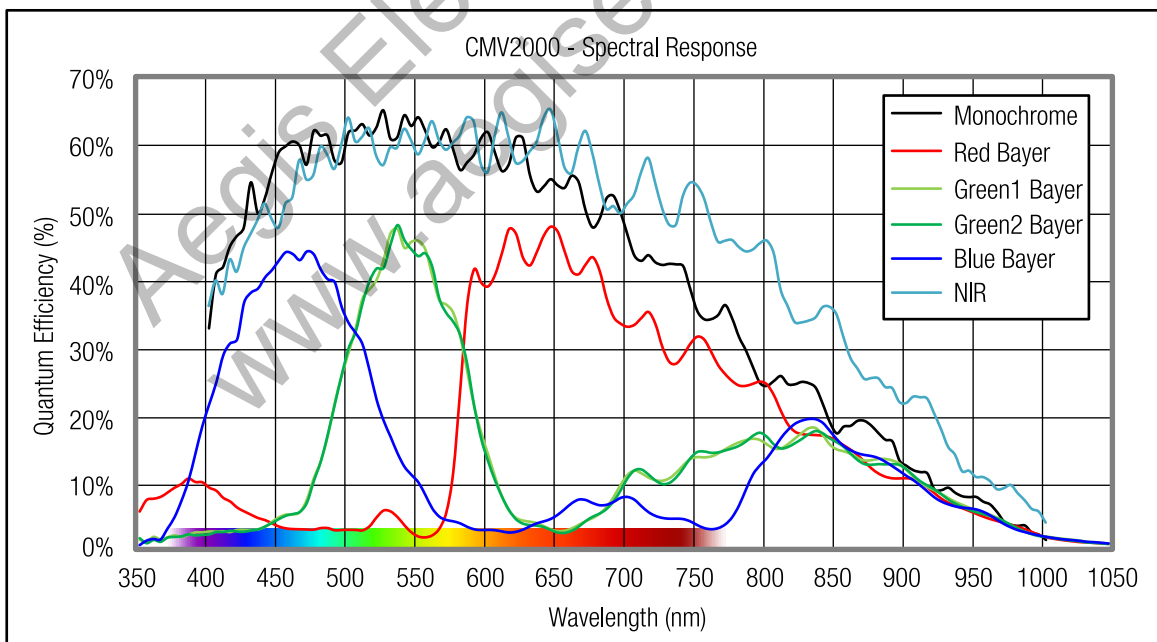

Figure 17: Graph quantum efficiency of CMOSIS CMV2000

Quantum efficiency curves for:
MQ042CG-CM-S7
MQ042CG-CM-S7-FL

MQ042RG-CM-S7
MQ042MG-CM-S7-FL

MQ042MG-CM-S7

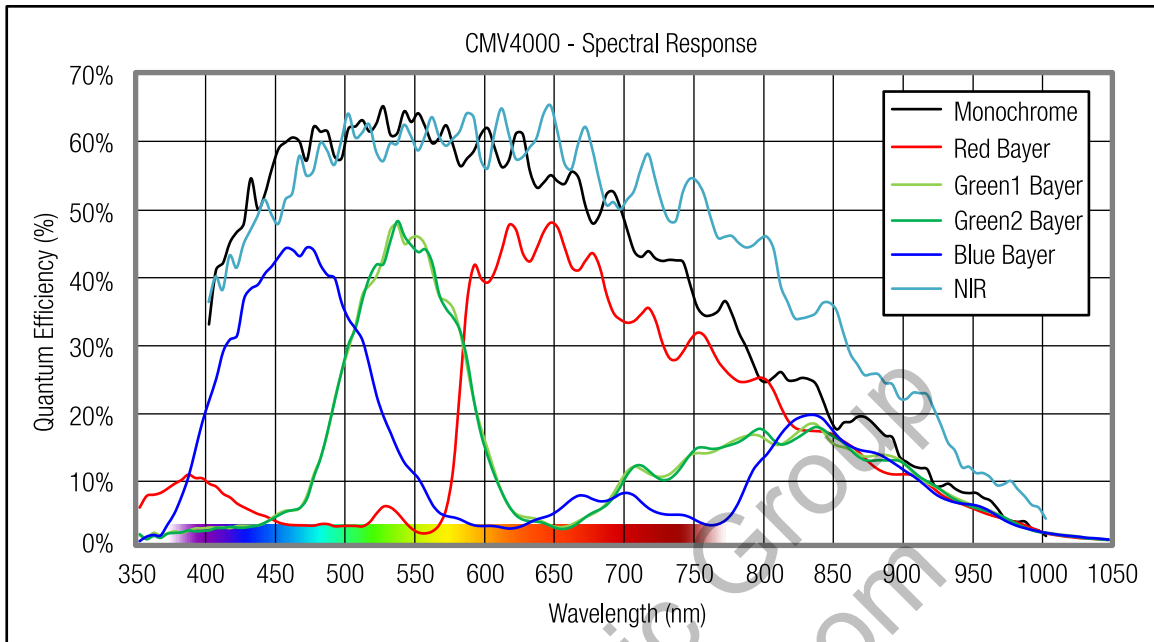

Figure 18: Graph quantum efficiency of CMOSIS CMV4000

Aegis Electronic Group
www.aegiselect.com

2.7 Mechanical characteristics

2.7.1 Dimensions and mass

Dimensions and mass of:
MQ013CG-E2-S7

MQ013MG-E2-S7

Width [W]	Height [H]	Depth ¹ [D]	Mass ¹ [M]
26.4 mm	26.4 mm	32.8 mm	30 g

¹without adapters

Table 30: Camera parameters of the specific models

Dimensions and mass of:
MQ013MG-E2-S7-NIO

MQ013CG-E2-S7-NIO

Width [W]	Height [H]	Depth ¹ [D]	Mass ¹ [M]
26.4 mm	26.4 mm	27.9 mm	30 g

¹without adapters

Table 31: Camera parameters of the specific models

Dimensions and mass of:
MQ013CG-ON-S7

MQ013MG-ON-S7

Width [W]	Height [H]	Depth ¹ [D]	Mass ¹ [M]
26.4 mm	26.4 mm	32.9 mm	30 g

¹without adapters

Table 32: Camera parameters of the specific models

Dimensions and mass of:
MQ013CG-E2-S7-FL
MQ013RG-E2-S7-FL

MQ013CG-E2-S7-FV
MQ013RG-E2-S7-FV

MQ013MG-E2-S7-FV

Width [W]	Height [H]	Depth ¹ [D]	Mass ¹ [M]
26.4 mm	26.4 mm	26.2 mm	26.6 g

¹without adapters

Table 33: Camera parameters of the specific models

Dimensions and mass of:
MQ022CG-CM-S7-FL

MQ022RG-CM-S7-FL

Width [W]	Height [H]	Depth ¹ [D]	Mass ¹ [M]
26.4 mm	26.4 mm	30.2 mm	31.8 g

¹without adapters

Table 34: Camera parameters of the specific models

Dimensions and mass of:
MQ022RG-CM-S7
MQ042CG-CM-S7

MQ022CG-CM-S7
MQ042RG-CM-S7

MQ022MG-CM-S7

Width [W]	Height [H]	Depth ¹ [D]	Mass ¹ [M]
26.4 mm	26.4 mm	36.8 mm	35 g

¹without adapters

Table 35: Camera parameters of the specific models

Dimensions and mass of:
MQ042CG-CM-S7-FL

MQ042MG-CM-S7-FL

Width [W]	Height [H]	Depth ¹ [D]	Mass ¹ [M]
26.4 mm	26.4 mm	30.1 mm	30.8 g

¹without adapters

Table 36: Camera parameters of the specific models

Dimensions and mass of:
MQ042MG-CM-S7-NIO

Width [W]	Height [H]	Depth ¹ [D]	Mass ¹ [M]
26.4 mm	26.4 mm	31.9 mm	30 g

¹without adapters

Table 37: Camera parameters of the specific models

2.7.2 Dimensional drawings

Dimensional drawings of:
MQ013CG-E2-S7

MQ013MG-E2-S7

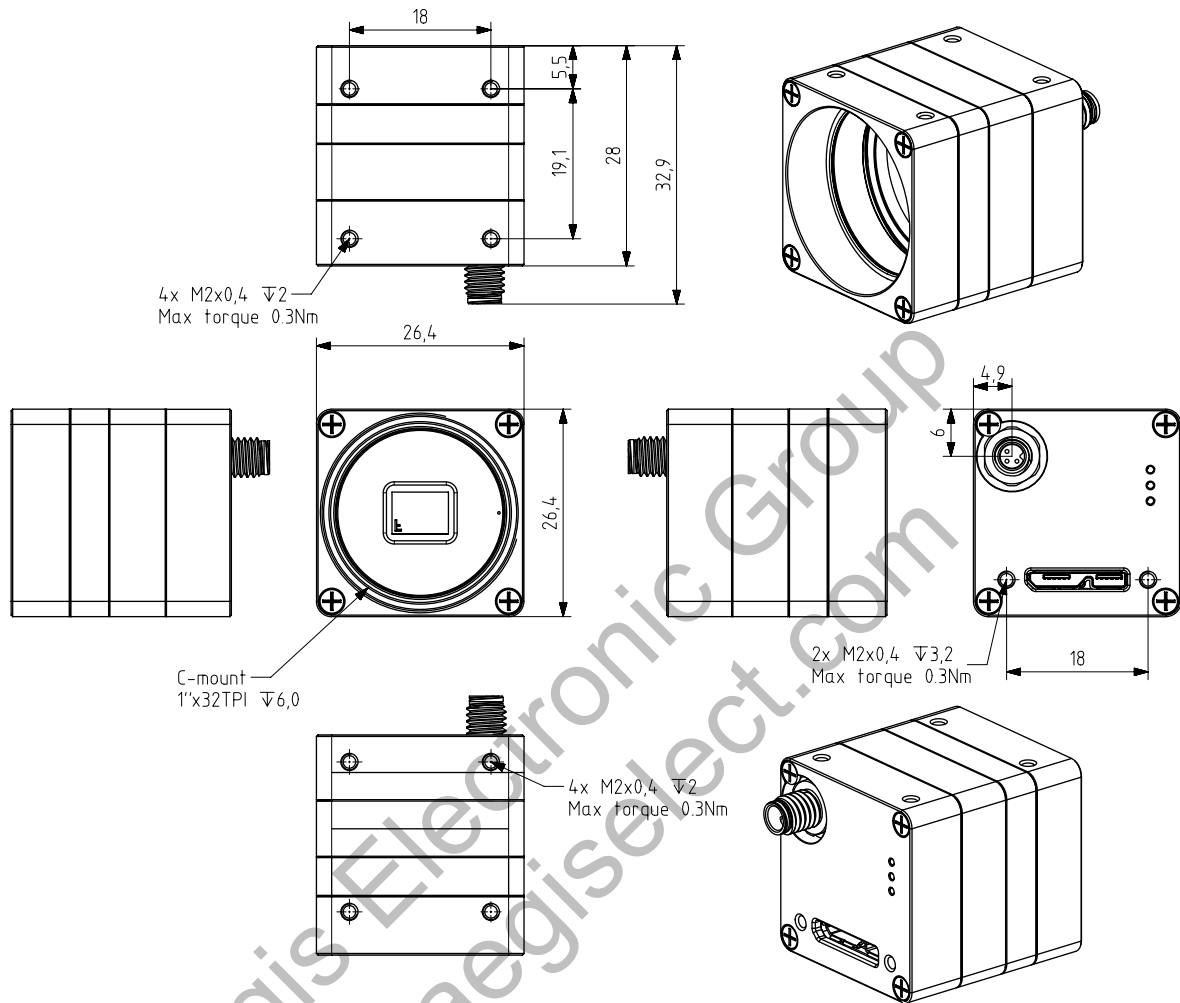

Figure 19: Dimensional drawing of MQ013xG-E2-S7

Dimensional drawings of:
MQ013CG-E2-S7-FV

MQ013MG-E2-S7-FV

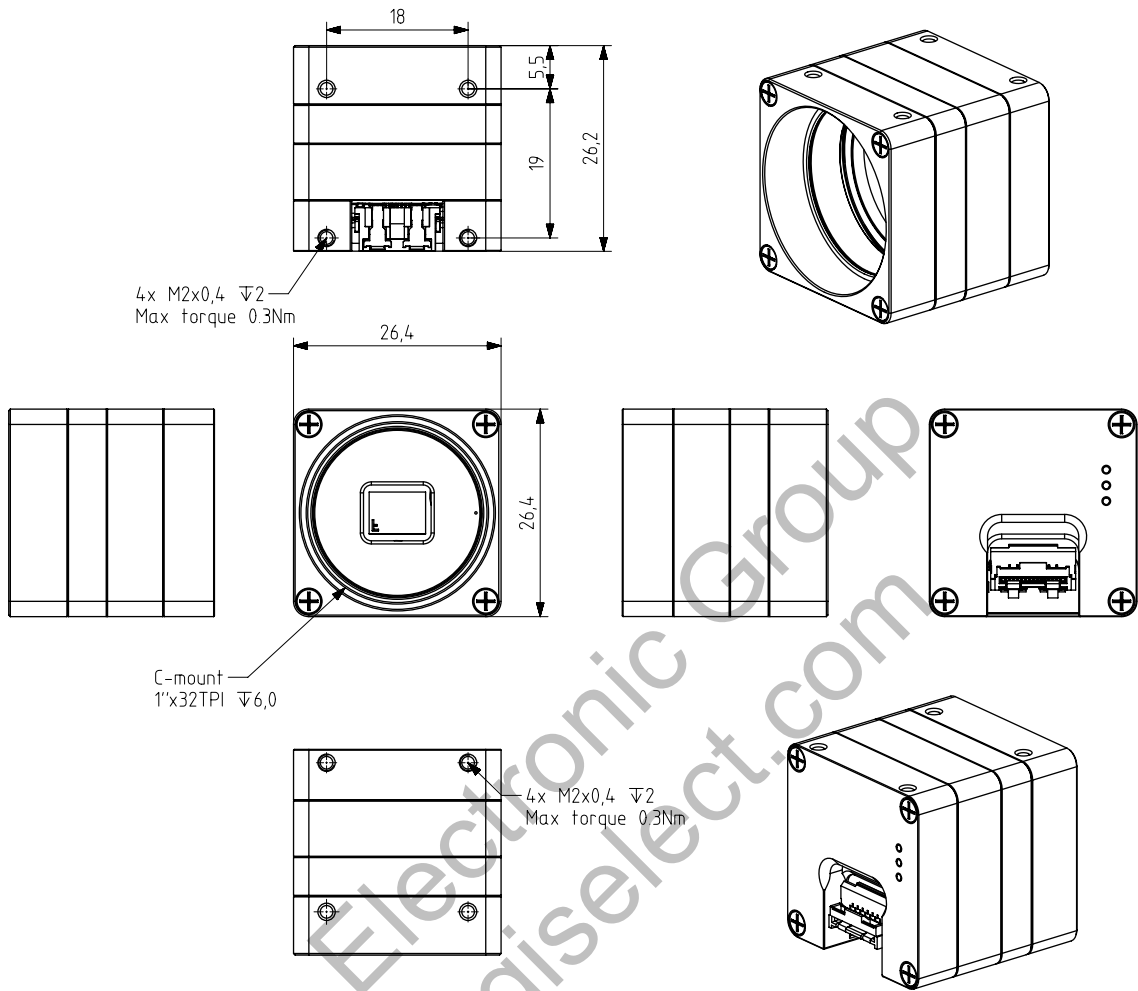

Figure 20: Dimensional drawing of MQ013xG-E2-FV

Dimensional drawings of:
MQ013MG-E2-S7-NIO

MQ013CG-E2-S7-NIO

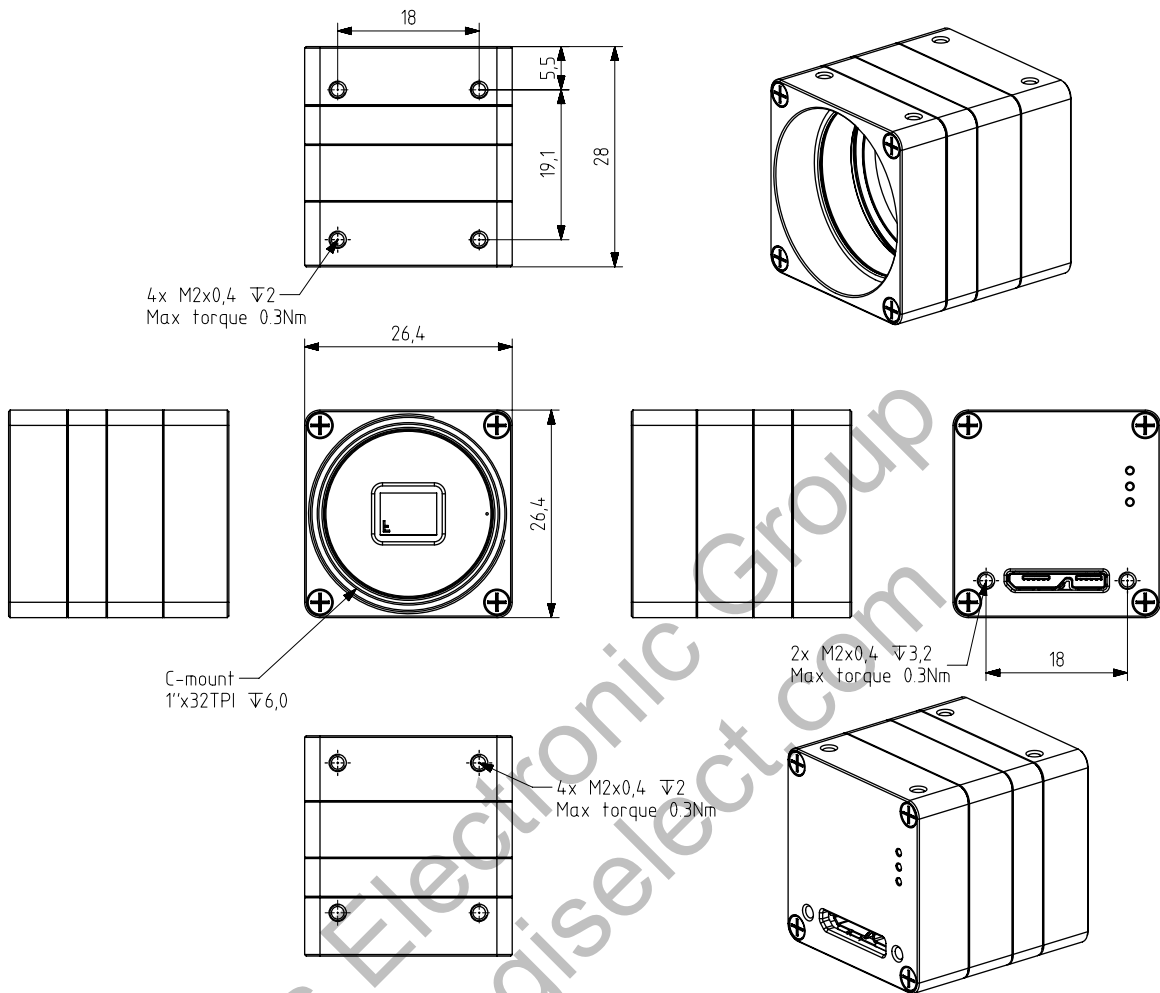

Figure 21: Dimensional drawing of MQ013xG-E2-S7-NIO

Dimensional drawings of:
MQ013CG-ON-S7

MQ013MG-ON-S7

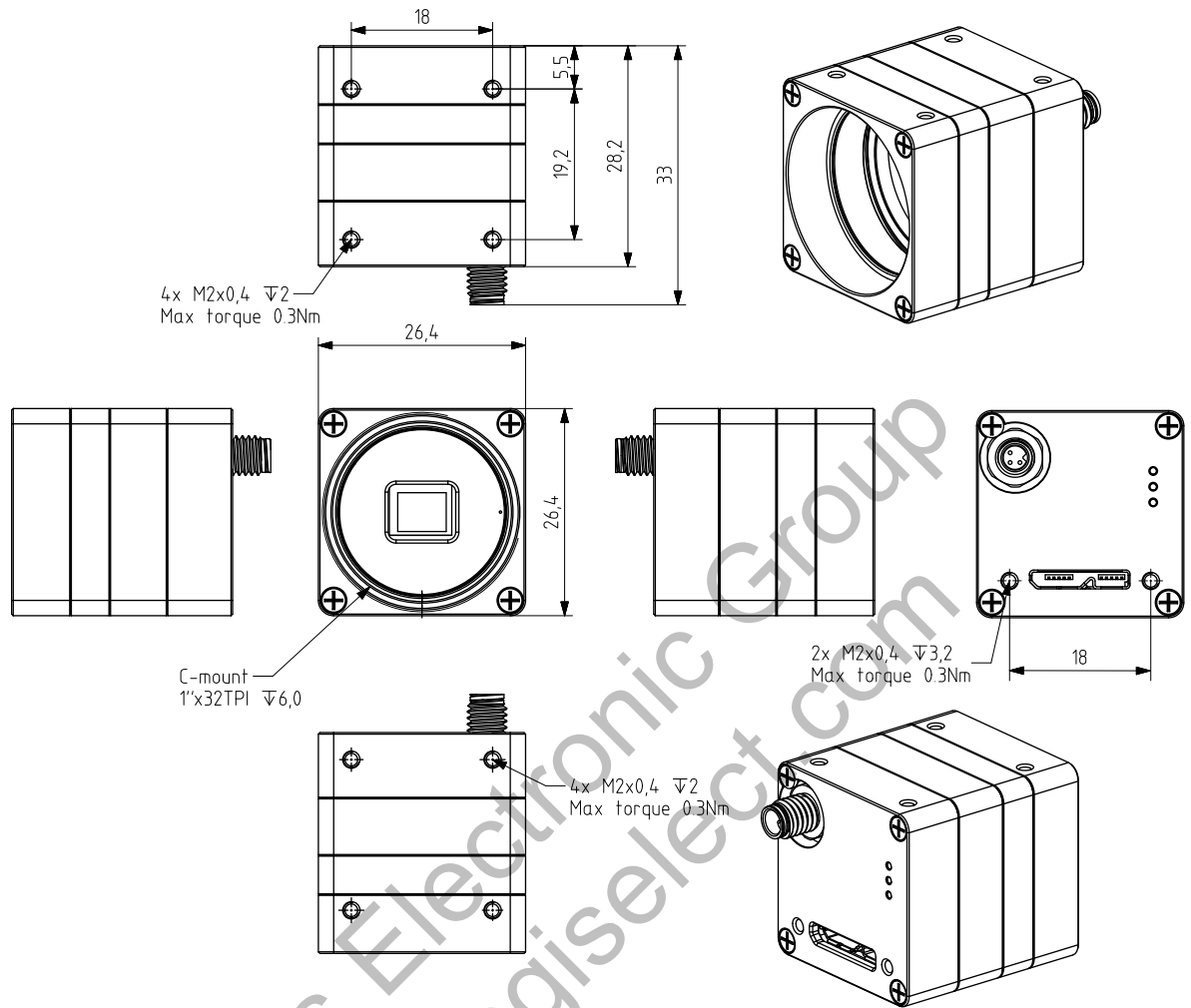

Figure 22: Dimensional drawing of MQ013xG-ON-S7

Dimensional drawings of:
MQ013CG-E2-S7-FL

MQ013RG-E2-S7-FL

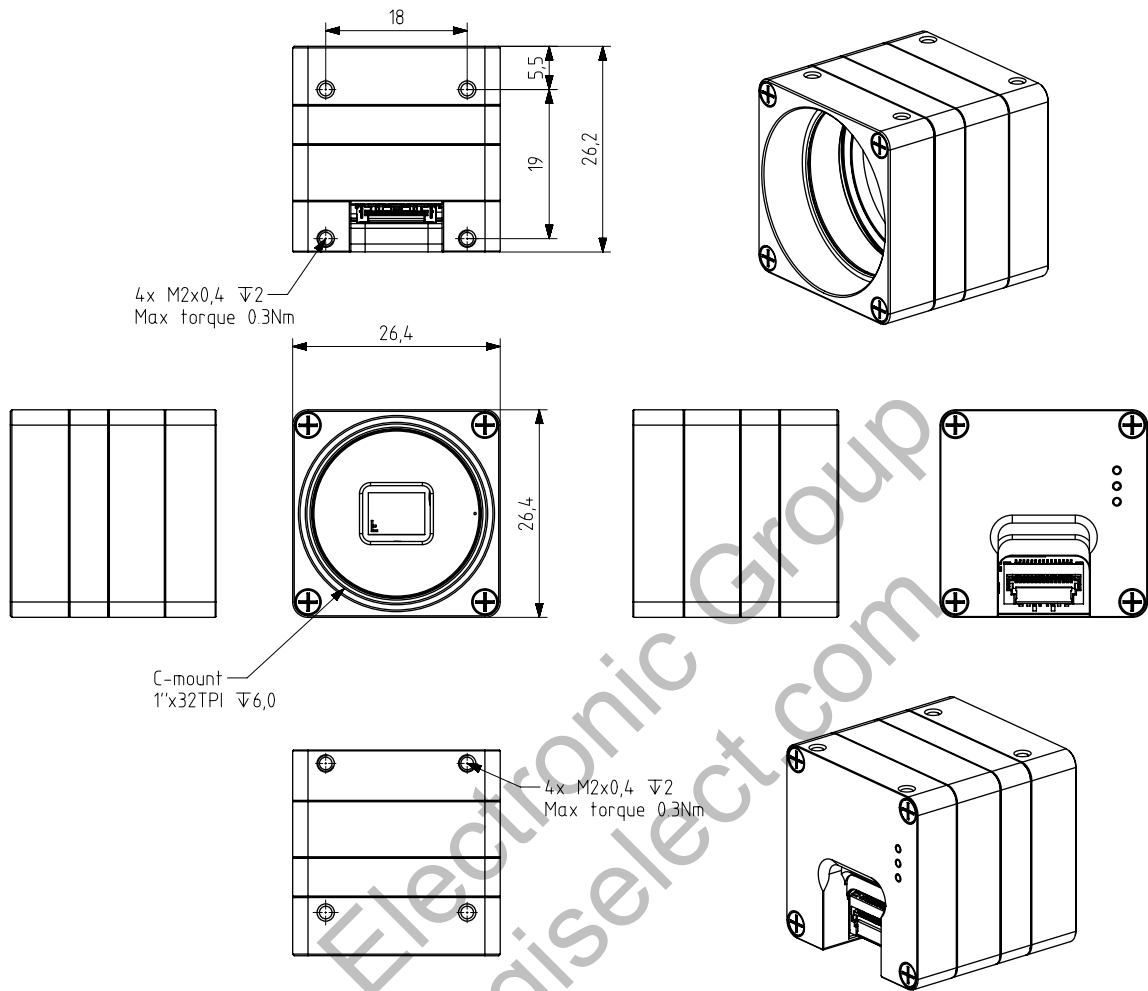

Figure 23: Dimensional drawing of MQ013xG-E2-FL

Dimensional drawings of:
 MQ022RG-CM-S7
 MQ042CG-CM-S7

MQ022CG-CM-S7
 MQ042RG-CM-S7

MQ022MG-CM-S7

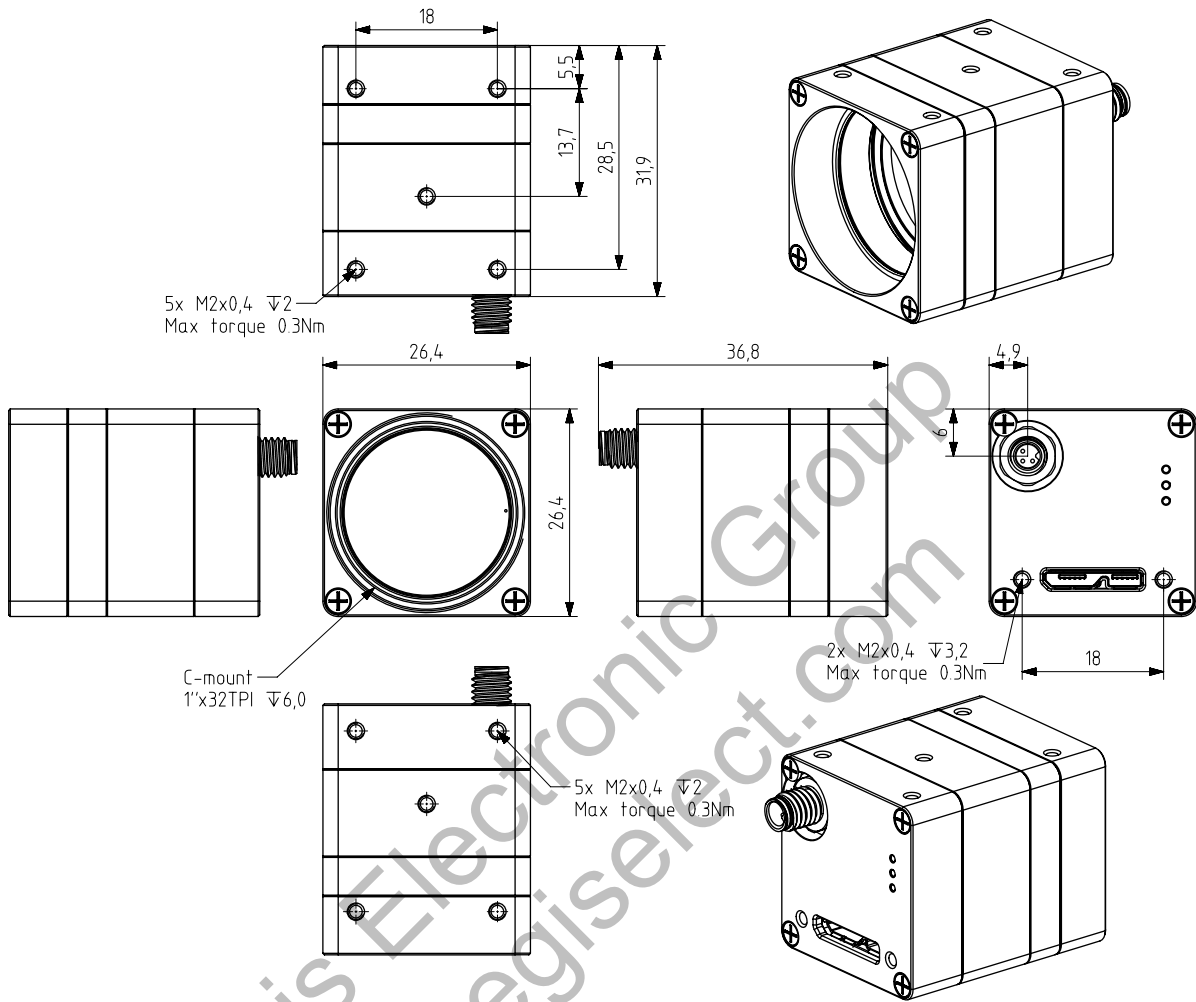

Figure 24: Dimensional drawing of MQ022/042xG-CM-S7

Dimensional drawings of:
 MQ022CG-CM-S7-FL
 MQ042CG-CM-S7-FL

MQ022RG-CM-S7-FL
 MQ042MG-CM-S7-FL

MQ022MG-CM-S7-FL

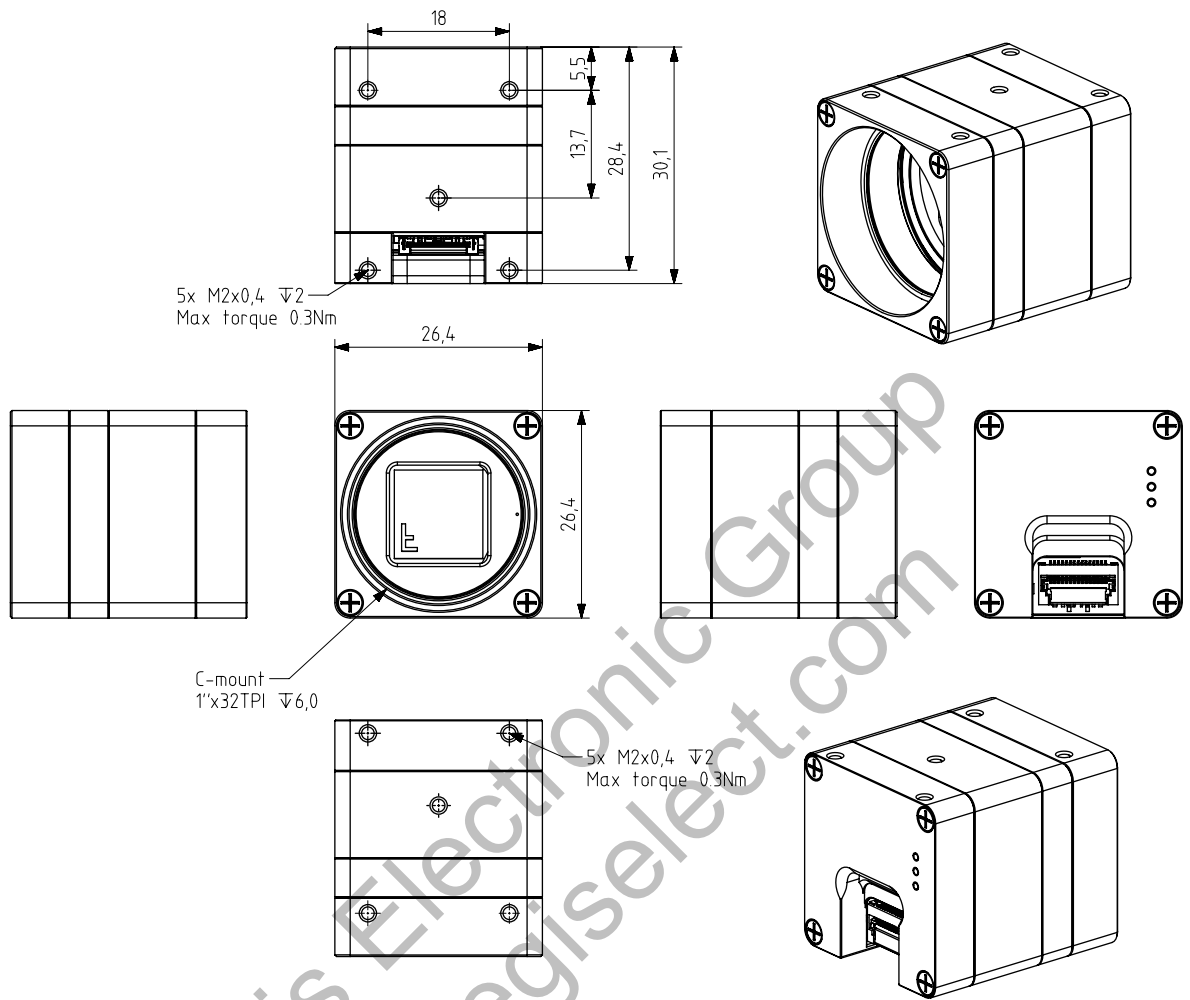

Figure 25: Dimensional drawing of MQ022xG-CM-FL

Dimensional drawings of:
MQ042MG-CM-S7-NIO

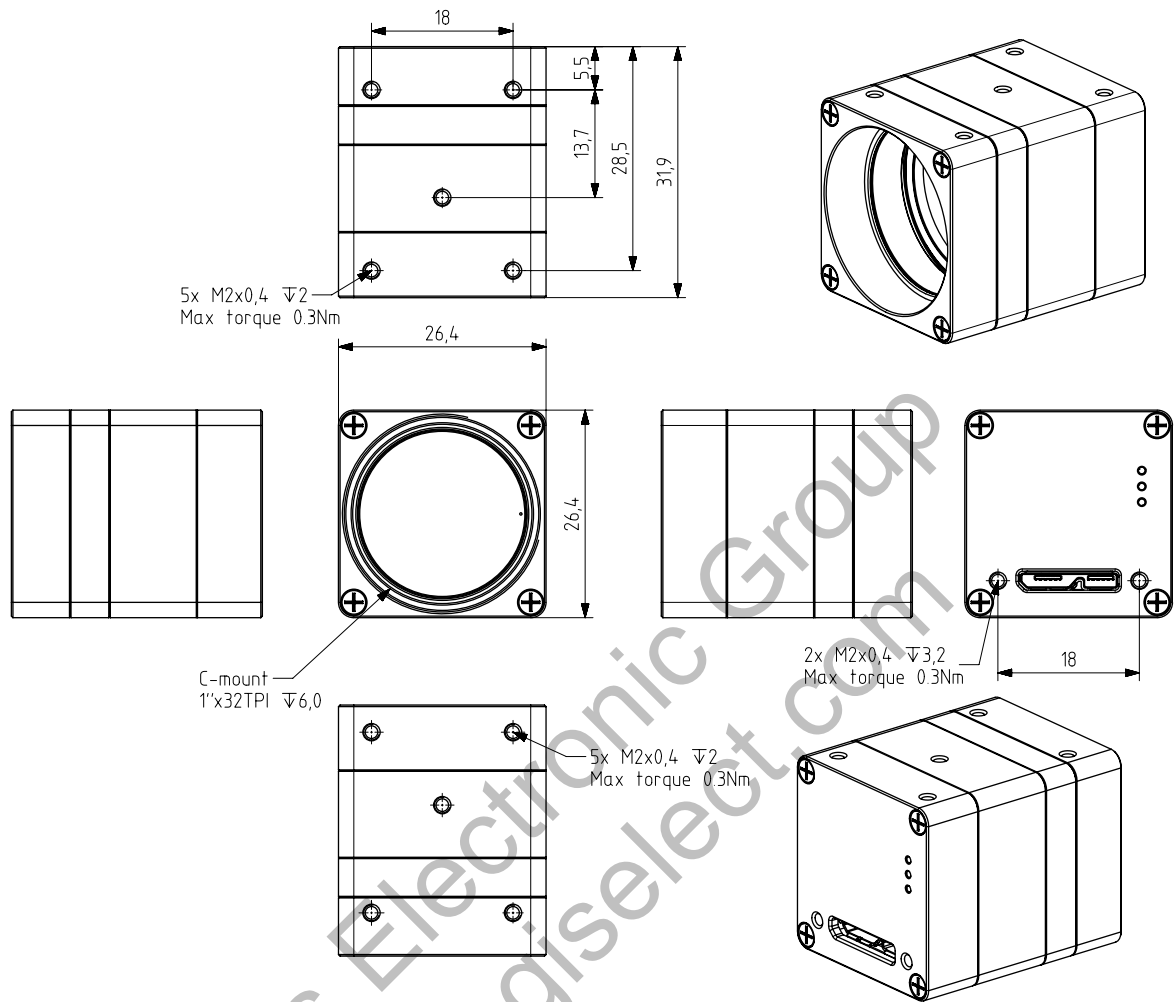

Figure 26: Dimensional drawing of MQ022/042xG-CM-S7-NIO

2.8 User interface – LEDs

LED	Color	Defaults	Note
1	Red	Streaming	User-configurable
2	Green	Connection status	User configurable
3	Orange	Camera is powered	User configurable (can be turned off)

Table 38: LED output description during camera power up

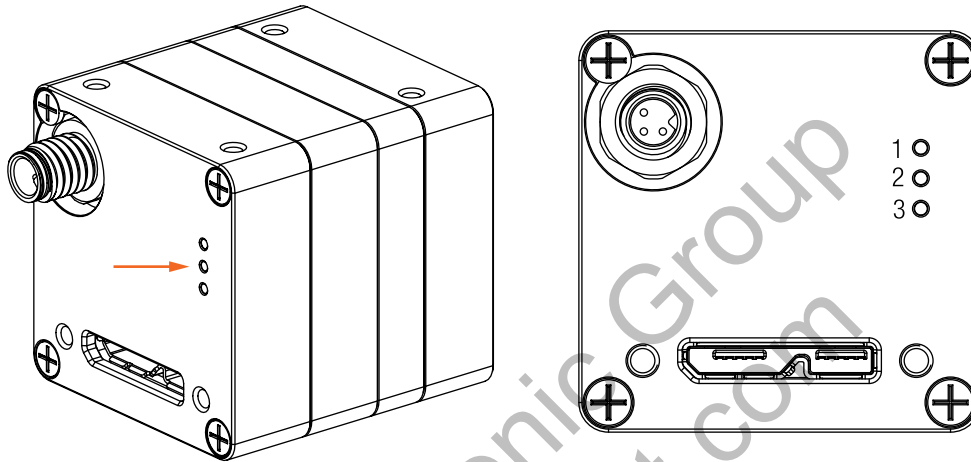

Figure 27: Position of LEDs on xiQ-S7 camera

LED statuses during boot sequence of:
all models in this manual (refer to the table [Models and sensors overview](#))

Status	LED 1	LED 2	LED 3
OFF	Off	Off	Off
Power	Off	Off	On
FPGA booted + FX3 booted	On	Off	On
HW SPI init	flash	1 Hz	Off
SW SPI init(wait for enum)	flash	2 Hz	Off
FX3_enumerated_as_USB2	Off	flash 2 Hz	On
FX3_enumerated_as_USB3	Off	On	On
Device stop	flash 2 Hz	flash 2 Hz	On
Error flash	2 Hz	async flash 2 Hz	On

Table 39: LED output description during camera power up

2.9 Camera interface

NOTE: It is important that the power is turned off when inserting/detaching the cable. General ESD precautions need to be applied. Failing this requirement may lead to camera damage.

The following section applies to:

MQ013CG-E2-S7

MQ013RG-ON-S7

MQ013RG-E2-S7-NIO

MQ022RG-CM-S7

MQ042CG-CM-S7

MQ042MG-CM-S7-NIO

MQ013MG-E2-S7

MQ013MG-E2-S7-NIO

MQ013CG-ON-S7

MQ022CG-CM-S7

MQ042RG-CM-S7

MQ013RG-E2-S7

MQ013CG-E2-S7-NIO

MQ013MG-ON-S7

MQ022MG-CM-S7

MQ042MG-CM-S7

2.9.1 USB 3 Gen1 micro-B

Item	Value
Connector	USB 3.1
Signals	Standard USB 3.1 Gen 1 Micro B Female Connector
Mating Connectors	Standard USB 3.1 Gen1 Micro-B Connector with thumbscrews ¹

¹Screw thread M2, thread distance 18.0 mm

Table 40: USB 3.1 micro-B mating connector description

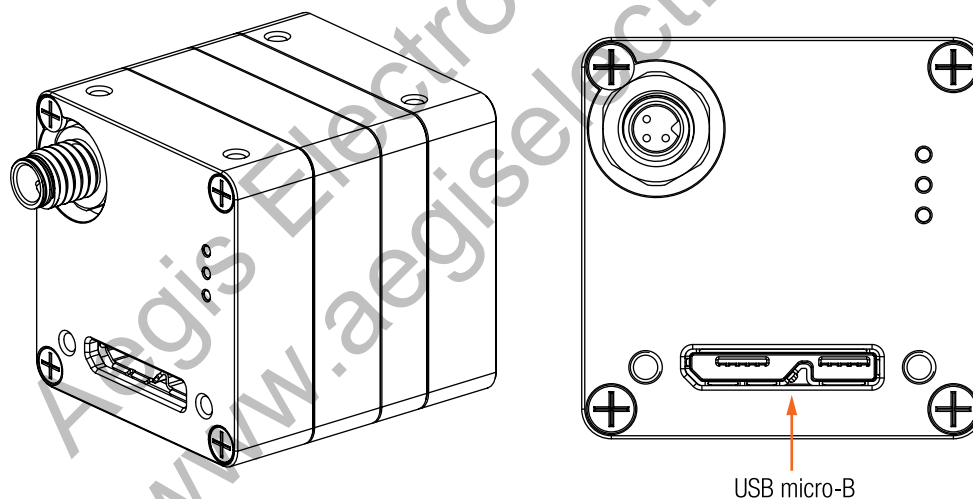

Figure 28: USB Micro-B connector location

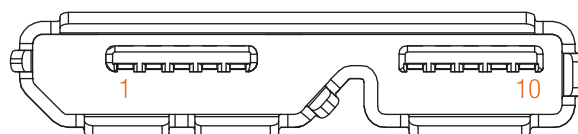

Figure 29: USB Micro-B connector pinning

Pin	Signal	Description
1	VBUS	Power input
2	D-	USB 2.0 signal pair
3	D+	USB 2.0 signal pair
4	ID	OTG Identification
5	GND	Power Ground
6	SSTX-	USB 3.0 SuperSpeed transmitter signal pair
7	SSTX+	USB 3.0 SuperSpeed transmitter signal pair
8	GND_DRAIN	USB 3.0 signal Ground
9	SSRX-	USB 3.0 SuperSpeed receiver signal pair
10	SSRX+	USB 3.0 SuperSpeed receiver signal pair

Table 41: USB 3.1 micro-B connector pin assignment

Aegis Electronic Group
www.aegiselect.com

The following section applies to:

MQ013CG-E2-S7-FL
 MQ013RG-E2-S7-FL
 MQ022CG-CM-S7-FL
 MQ042CG-CM-S7-FL

MQ013CG-E2-S7-FV
 MQ013RG-E2-S7-FV
 MQ022RG-CM-S7-FL
 MQ042MG-CM-S7-FL

MQ013MG-E2-S7-FV
 MQ013MG-E2-S7-FL
 MQ022MG-CM-S7-FL

2.9.2 Flex cable interface

The flex cable interface is located on the back of the camera and comes with two different options based on the orientation the cable plugs into the camera. The (FL) version of the camera allows the cable to approach from the bottom of the camera and the (FV) version has the cable connecting to the camera perpendicular to the sensor surface. The flex line cameras have one input and one output (GPIO) available through the flex line (see [Digital inputs / outputs \(GPIO\) interface](#) for pinout description).

Item	Value
Connector	Molex 502244-15300 (-FL), Molex 502231-1500 (-FV)
Signals	USB 3.1 Gen1, power, IO
Mating Connectors	CBL-MQ-FL-0M1, CBL-MQ-FL-0M25

Table 42: Flex cable interface mating connector description

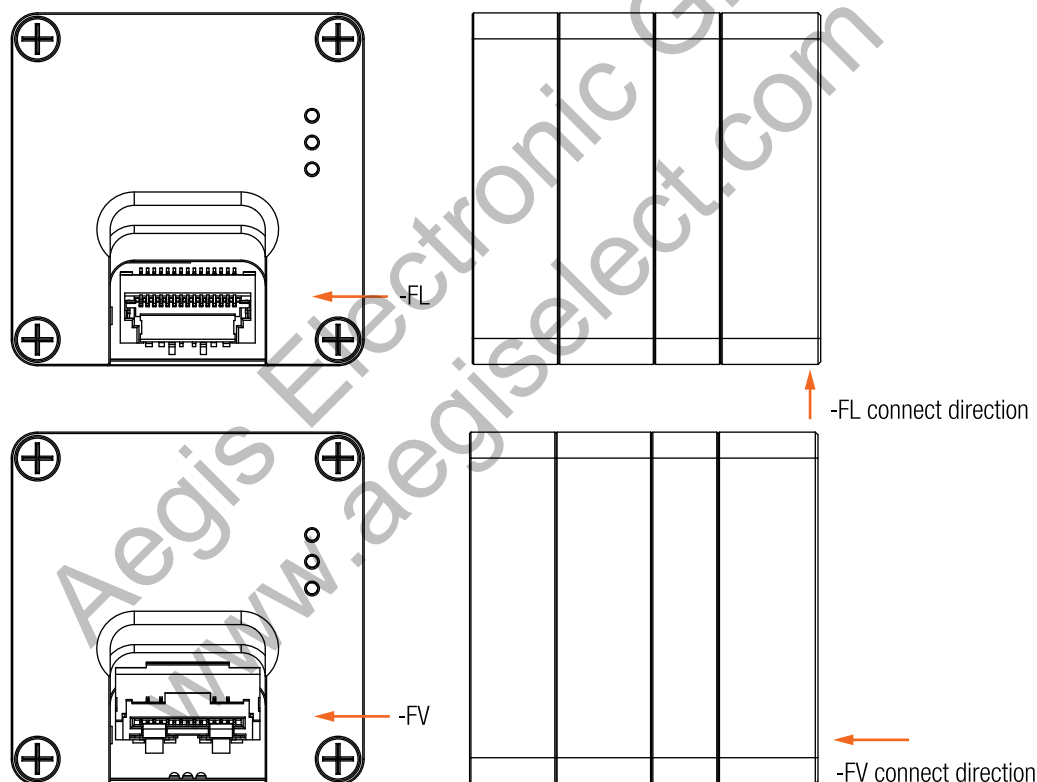

Figure 30: Flex connector location

2.10 Digital inputs / outputs (GPIO) interface

The description of the GPIO interface is applicable to:

MQ013CG-E2-S7	MQ013MG-E2-S7	MQ013RG-E2-S7
MQ013CG-ON-S7	MQ013MG-ON-S7	MQ013RG-ON-S7
MQ022RG-CM-S7	MQ022CG-CM-S7	MQ022MG-CM-S7
MQ042CG-CM-S7	MQ042RG-CM-S7	

Item	Value
Connector	I/O & Binder 09 3105 81 03
Signals	Digital Input and Output
Mating Connectors	Binder 77 3550 0000 40003-0x000 (connector on cable side)

Table 43: GPIO mating connector description

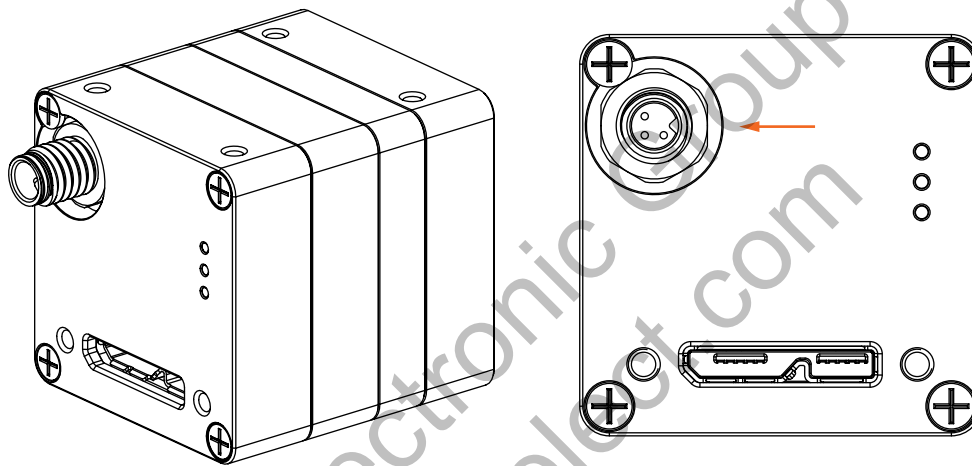

Figure 31: IO connector location

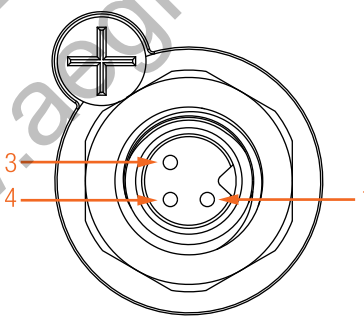

Figure 32: IO connector pinning

Pin	Name	GPI/GPO index API	Type
1	GPIO_GND	None	Common ground for Opto-Isolated Input and Output
3	IN	1/-	Optically isolated Digital Input (IN)
4	OUT	-/1	Optically isolated Digital Output (OUT)

Table 44: I/O connector pin assignment

The description of the GPIO interface is applicable to:

MQ013CG-E2-S7-FL
 MQ013RG-E2-S7-FL
 MQ022CG-CM-S7-FL
 MQ042CG-CM-S7-FL

MQ013CG-E2-S7-FV
 MQ013RG-E2-S7-FV
 MQ022RG-CM-S7-FL
 MQ042MG-CM-S7-FL

MQ013MG-E2-S7-FV
 MQ013MG-E2-S7-FL
 MQ022MG-CM-S7-FL

Item	Value
Connector	Molex 502244-15300 (-FL), Molex 502231-1500 (-FV)
Signals	USB 3.1 Gen1, power, IO
Mating Connectors	CBL-MQ-FL-0M1, CBL-MQ-FL-0M25

Table 45: GPIO mating connector description

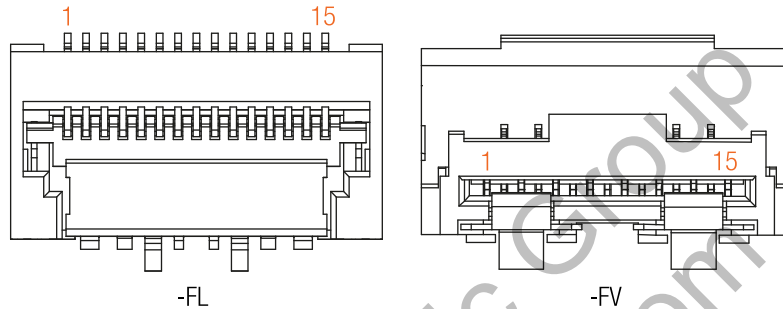

Figure 33: Flex / IO connector pinning

Pin	Name	GPI/GPO index API	Type
1	GND	None	Ground for pwr. and SuperSpeed signal return
2	SSRX-	None	SuperSpeed receiver differential pair
3	SSRX+	None	SuperSpeed receiver differential pair
4	GND	None	Ground for pwr. and SuperSpeed signal return
5	SSTX+	None	SuperSpeed transmitter differential pair
6	SSTX-	None	SuperSpeed transmitter differential pair
7	GND	None	Ground for pwr. and SuperSpeed signal return
8	D+	None	USB 2.0 differential pair
9	D-	None	USB 2.0 differential pair
10	GND	None	Ground for pwr. and SuperSpeed signal return
11	VBUS	None	Power input
12	VBUS	None	Power input
13	OUT1	-/1	Optically isolated Digital Output (OUT)
14	IN/OUT GND	None	Common pole (IO Ground)
15	IN1	1/-	Optically isolated Digital Input (IN)
Gnd. pins	SGND	None	Shield of FPC cbl. connected to shield of host controller

Table 46: I/O connector pin assignment

Description of digital inputs below is applicable to:

MQ013CG-E2-S7
 MQ013MG-E2-S7-FV
 MQ013RG-ON-S7
 MQ013RG-E2-S7-FL
 MQ022RG-CM-S7
 MQ022CG-CM-S7-FL
 MQ042CG-CM-S7
 MQ042CG-CM-S7-FL

MQ013MG-E2-S7
 MQ013CG-ON-S7
 MQ013CG-E2-S7-FL
 MQ013RG-E2-S7-FV
 MQ022CG-CM-S7
 MQ022RG-CM-S7-FL
 MQ042RG-CM-S7
 MQ042MG-CM-S7-FL

MQ013RG-E2-S7
 MQ013MG-ON-S7
 MQ013CG-E2-S7-FV
 MQ013MG-E2-S7-FL
 MQ022MG-CM-S7
 MQ022MG-CM-S7-FL
 MQ042MG-CM-S7

2.10.1 Optically isolated Digital Input (IN)

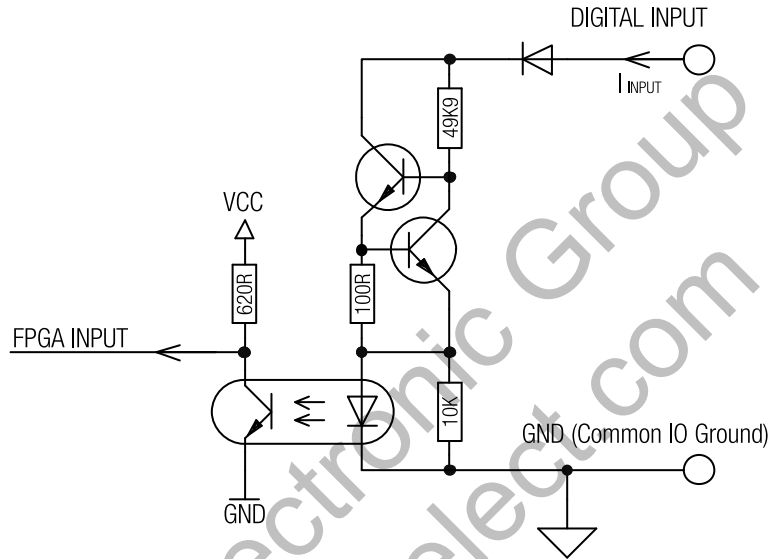

Figure 34: Digital input, interface schematic

Item	Parameter	Note
Maximal input voltage	24 V DC	None
Common pole	YES	IN GND
Effect of incorrect input terminal connection	Reverse voltage polarity protected	None
Effects when withdrawing/inserting input module under power	no damage, no lost data	None
Maximal recommended cable length	10 m	None
Input Level for logical 0	Voltage < 2.0 V / Current < 0.5 mA	None
Input Level for logical 1	Voltage > 4.0 V / Current > 2 mA	None
Input debounce filter	No	None
Input delay - rising edge	1.7+-0.2 μ s	VINPUT=10 V, TAMBIENT=25 $^{\circ}$ C
Input delay - falling edge	10.7+-0.2 μ s	VINPUT=10 V, TAMBIENT=25 $^{\circ}$ C
External trigger mapping	YES	None
Input functions	Trigger	Rising or falling edge are supported for trigger

Table 47: General info for optically isolated digital input

Aegis Electronic Group
www.aegiselect.com

Description of digital outputs below is applicable to:

- | | | |
|------------------|------------------|------------------|
| MQ013CG-E2-S7 | MQ013MG-E2-S7 | MQ013RG-E2-S7 |
| MQ013MG-E2-S7-FV | MQ013CG-ON-S7 | MQ013MG-ON-S7 |
| MQ013RG-ON-S7 | MQ013CG-E2-S7-FL | MQ013CG-E2-S7-FV |
| MQ013RG-E2-S7-FL | MQ013RG-E2-S7-FV | MQ013MG-E2-S7-FL |
| MQ022RG-CM-S7 | MQ022CG-CM-S7 | MQ022MG-CM-S7 |
| MQ022CG-CM-S7-FL | MQ022RG-CM-S7-FL | MQ022MG-CM-S7-FL |
| MQ042CG-CM-S7 | MQ042RG-CM-S7 | MQ042MG-CM-S7 |
| MQ042CG-CM-S7-FL | MQ042MG-CM-S7-FL | |

2.10.2 Optically isolated Digital Output (OUT)

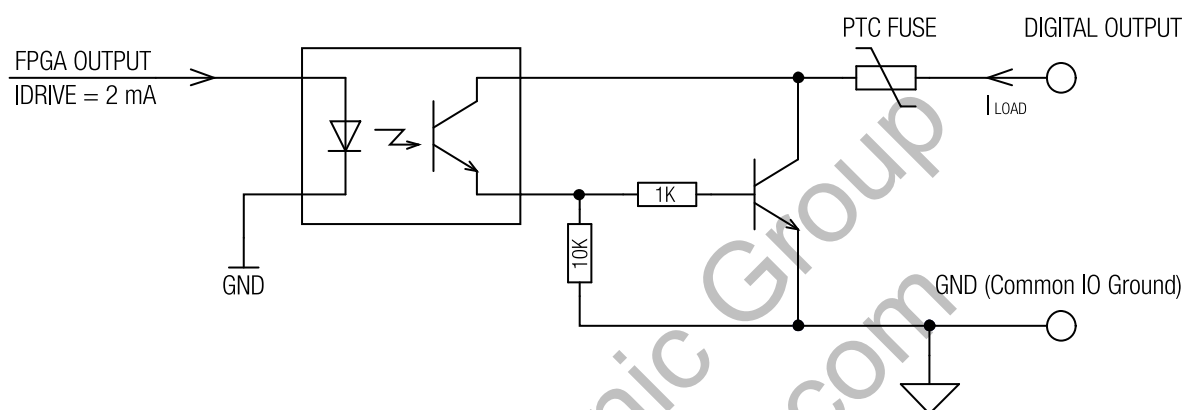

Figure 35: Digital output, interface schematic

Item	Parameter	Note
Maximal open circuit voltage	24 V DC	None
Output port type	Open collector NPN	None
Common pole	YES	OUT GND
Protection	short-circuit / over-current / Reverse voltage	None
Protection circuit	PTC Resettable Fuse	None
Maximal sink current	25 mA	None
Trip current	50 mA	Self-restarting when failure mode current disconnected
Inductive loads	false	None
Effect of incorrect output terminal connection	Protected against reverse voltage connection	None
Maximal output dropout	1 V	Sink current 25 mA
Output delay - rising edge	51 μ s	VOUTPUT=10 V, TAMBIENT=25 °C
Output delay - falling edge	0.8 μ s	VOUTPUT=10 V, TAMBIENT=25 °C
Strobe output mapping	YES	None

Table 48: General info for optically isolated digital output

2.11 Accessories

2.11.1 CBL-U3-xM

1.0 m / 3.0 m / 5.0 m USB 3.0 cable.

USB3 cable, components

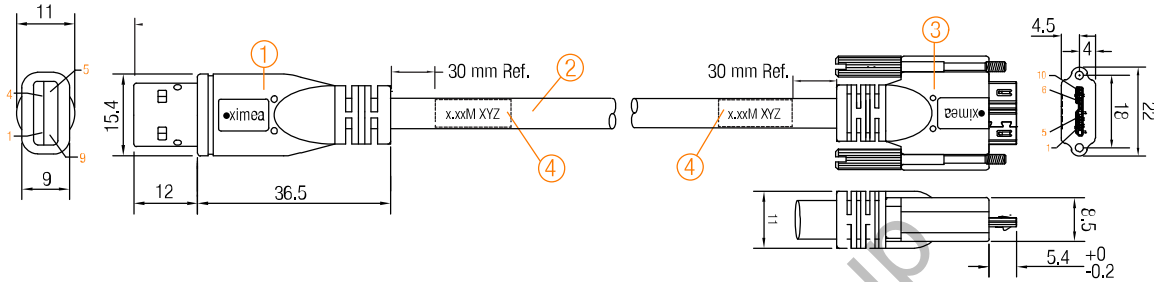

Figure 36: USB type-C cable

- 1 USB A 3.0 9 pin Molded Plug <BLK>
- 2 MCD-USB-211 [OD = 7.3 mm] <BLK>
- 3 3 USB MicB 3.0 sl 10 pin Molded Plug with Screw Locking <BLK>
- 4 Cable Label

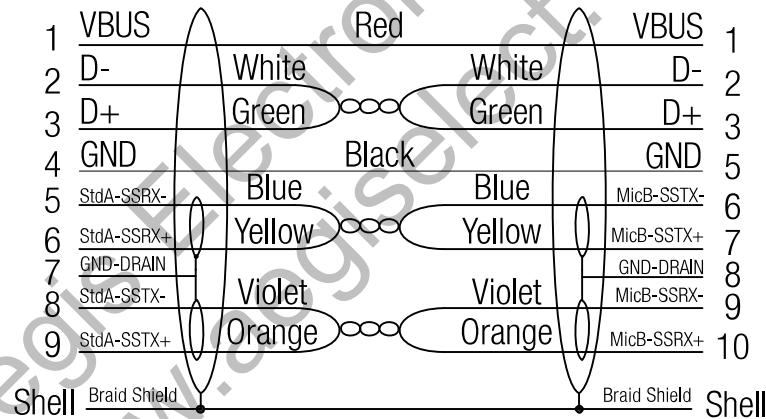

Figure 37: wiring USB3 cable

Pin	Signal	Description
1	VBUS	Power
2	D-	USB 2.0 signal pair
3	D+	
4	ID	OTG Identification
5	GND	Power Ground
6	MicB_SSTX-	USB 3.0 SuperSpeed transmitter signal pair
7	MicB_SSTX+	
8	GND_DRAIN	USB 3.0 signal Ground
9	MicB_SSRX-	USB 3.0 SuperSpeed receiver signal pair
10	MicB_SSRX+	

Table 49: CBL-U3-xM pin assignment

2.11.2 CBL-U3-3M0-ANG

3.0m USB 3.0 cable, angled micro USB3 connector

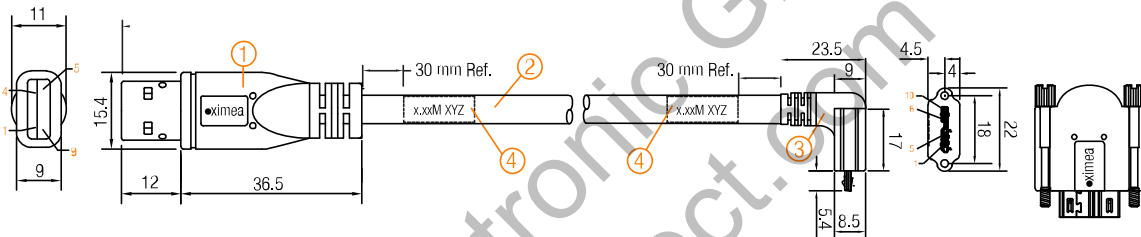

Figure 38: USB3 cable angled

USB3 cable angled, components

- 1 USB A 3.0 9 pin Molded Plug <BLK>
- 2 A12-7143 [OD = 5.9 mm] <BLK> UL20726 2STP#30 + 1UTP#28 + 2C#26
- 3 USB MicB 3.0 sl 90D A1(10 pin Molded Plug) <BLK>
- 4 Cable Label

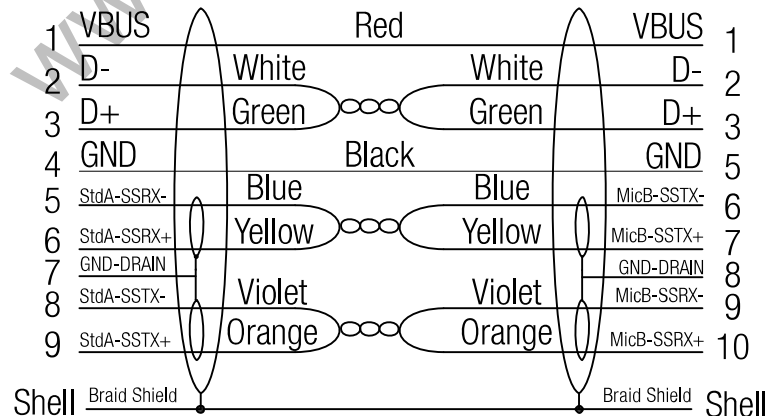

Figure 39: wiring USB3 cable

Pin	Signal	Description
1	VBUS	Power
2	D-	USB 2.0 signal pair
3	D+	
4	ID	OTG Identification
5	GND	Power Ground
6	MicB_SSTX-	USB 3.0 SuperSpeed transmitter signal pair
7	MicB_SSTX+	
8	GND_DRAIN	USB 3.0 signal Ground
9	MicB_SSRX-	USB 3.0 SuperSpeed receiver signal pair
10	MicB_SSRX+	

Table 50: pin assignment

Aegis Electronic Group
www.aegiselect.com

2.11.3 CBL-MQ-FL-xM

Cable FPC MQ Flex-Line, 0.1 m, 0.25 m can be used for connecting xiC flex line models to carrier board or trough adapter and standard USB 3.0 cable to the host computer. Minimal advised bending radius is 2 mm. Cable thickness 0.16 mm.



Figure 40: CBL-MQ-FL-xM

Note: Cable have marked ends. It is important to connect the end marked “CAM” to the camera and end marked “BOB” to host or adapter. Swapped orientation leads to nonoperational state. Connecting camera to powered host can cause destruction of camera. For detaching cable, the connector needs to be unlocked, otherwise connector soldering may be damaged.

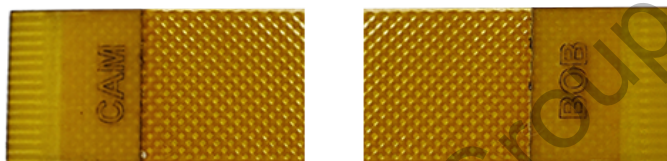

Figure 41: CBL-MQ-FL-xM zoom

2.11.4 CBL-USB3FLEX-xM

The newer generation of FFC cable with available lengths 0.1 m, 0.25 m, 5 m can be used for connecting camera to carrier board or trough adapter to the host computer. Minimal advised bending radius is 5 mm. Cable thickness 0.38 mm. This cable is NOT polarized and either end can be used for the camera or the host.



Figure 42: CBL-USB3FLEX-xM

2.11.5 CBL-S-M5-3P-PT-xM

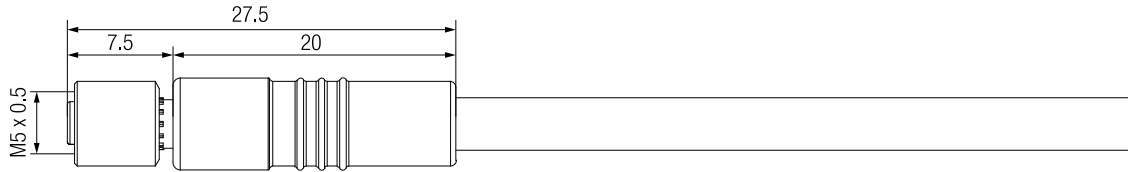

Figure 43: CBL-S-M5-3P-PT-xM

Connect optically isolated input and output to the xiQ-S7 family of cameras. Also connect non-isolated IO to the xiMU cameras featuring binder connector. 3 pin IO cable for cameras featuring M5 connector, two variants of cable are available:

- Part number** CBL-S-M5-3P-PT-5M0
- Binder part number** 77 3450 0000 40003-0500
- Description** M5 Female cable connector, Contacts: 3, unshielded, moulded on the cable, IP67, UL, M5x0.5, PUR, black, 3 × 0.14 mm, 5 m
- Part number** CBL-S-M5-3P-PT-5M0-S
- Binder part number** 77 3550 0000 40003-0500
- Description** M5 Female cable connector, Contacts: 3, shielded, moulded on the cable, IP67, M5x0.5, PUR, black, 3 × 0.14 mm, 5 m

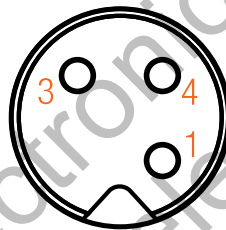

Figure 44: CBL-S-M5-3P-PT-xM pinout

Pin	Wire color	Signal MQ-S7	Signal MU
1	brown	GPIO_GND	GND
2	-	-	-
3	blue	IN	INOUT 1
4	black	OUT	OUT 1
Shielding	-	connected to camera housing ¹	connected to camera housing ¹

¹Only for CBL-S-M5-3P-PT-5M0-S variant

Table 51: CBL-S-M5-3P-PT-xM pin assignment

2.11.6 CBL-S-PB3-PT-0M30

IO pigtail cable is for board-level variants of MQ cameras. Connects optically isolated input and output to xiQ-S7 family of cameras. For more information contact our [XIMEA Support Team](#).

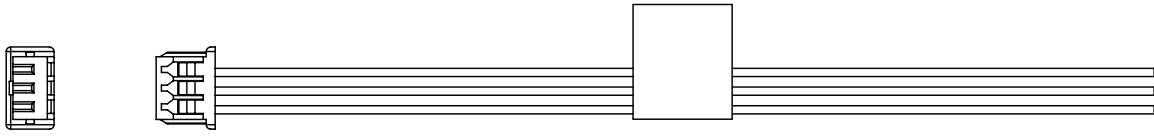

Figure 45: CBL-S-PB3-PT-0M30

Pin	Signal MQ-S7
1	GPIO_GND
2	IN
3	OUT

Table 52: CBL-S-PB3-PT-0M30 pin assignment

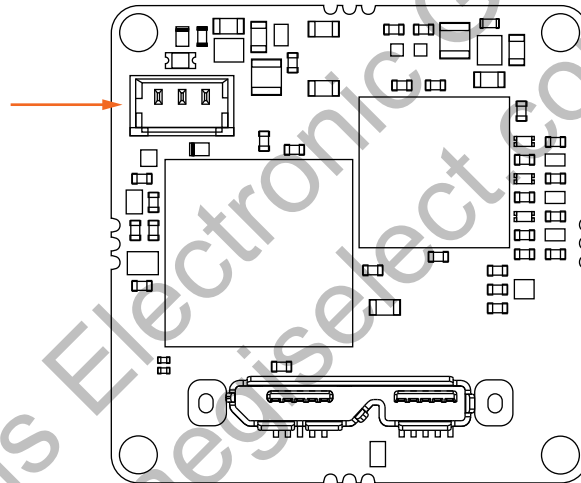

Figure 46: board-level camera - connector location

2.11.7 BOB-MQ-FL

Break Out Board, Simple Board Level. Enables access to the optoisolated input and output. FPC cable connector pinout is exactly mirrored from camera pinout.

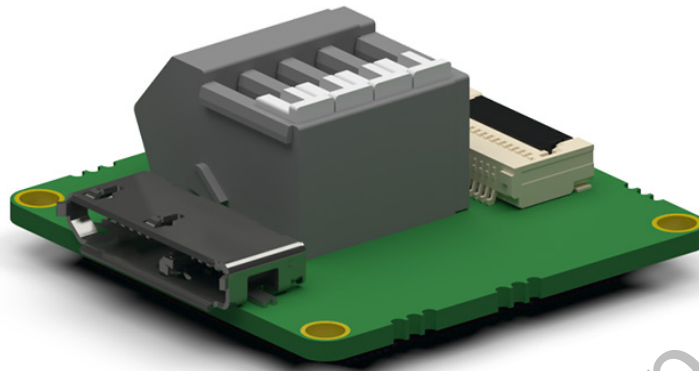

Figure 47: BOB-MQ-FL dimensions

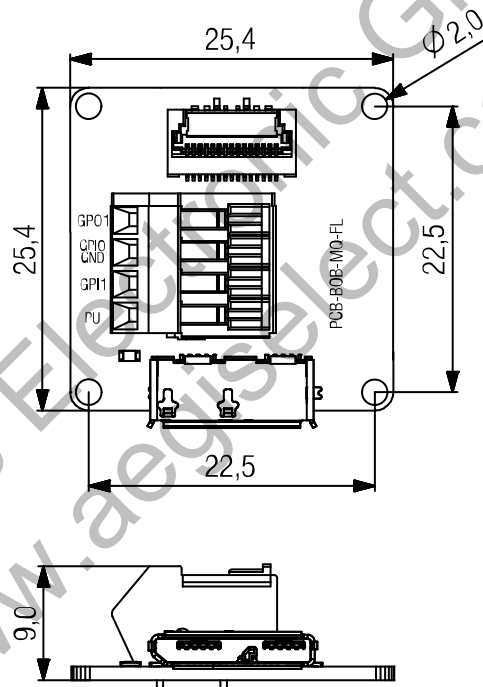

Figure 48: BOB-MQ-FL dimensions

Pin	Signal	Description
1	GPO1	Trigger/sync digital Output (GPO) - Open collector NPN – connected to pin 3 on Flex connector
2	GPIO	GND GPO1 and GPI1 common ground – connected to pin2 on Flex connector
3	GPI1	Trigger/sync digital Input (GPI) Current limited input – connected to pin1 on Flex connector
4	PU	Pull up 1 k Ω to GPO1 – Connect power supply up to 25 V if needed

Table 53: IO connector (WAGO 218-104), pin assignment

2.11.8 MQ-BRACKET-T



Figure 49: MQ-BRACKET-T

Tripod mounting bracket with 1/4-20 thread. Use 4x SROB-M2x4-CUST screws for mounting. Bracket can be mounted on the bottom or top side of the camera. Brackets are delivered as kit with respective screws. There are two variants. Standard MQ-BRACKET-T-KIT with height of 5.5 mm and thick MQ-BRACKET-T-THICK-KIT for use with lenses with diameter > 37 mm³⁷

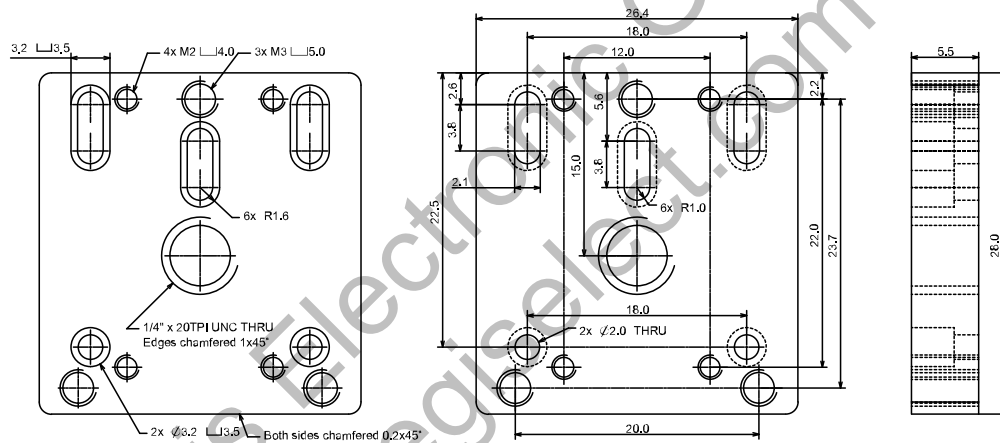

Figure 50: MQ-BRACKET-T dimensional drawing

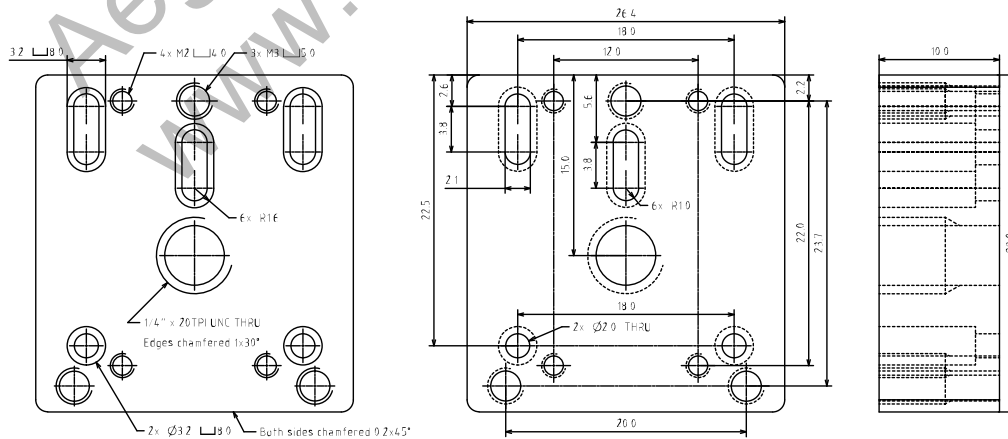

Figure 51: MQ-BRACKET-T thick dimensional drawing

2.11.9 USB 3 host adapters

USB 3.0 to PCI Express x1 Gen2 Host Card

Please refer to following page [USB 3 Host Adapters](#) for more information.

USB 3.1 Host Adapter

For a stable operation of your camera and achieving the maximum possible system performance with the highest frame rate it is important to choose an appropriate USB 3.1 host adapter chipset. Please have a look at the following link to our webpage: [USB3 Hardware Compatibility](#)

XIMEA maintains a regularly updated overview of compatible USB 3.0 and USB 3.1 host adapters together with the available bandwidth [USB 3 Host Adapters](#)

The maximum data transfer rate depends on different conditions (motherboard, chipset, driver version, operating system, etc.).

PCI Express (PCIe) bus speed requirement: To achieve maximum performance of USB3 cameras - USB 3.1 host adapter must be connected to the PCIe slot/port/hub and running at 5 GT/s in case of PCIe Gen2 host adapters. For cards requiring Gen3 the speed needs to be 8 GT/s.

Aegis Electronic Group
www.aegiselect.com

3 General features

3.1 Camera features

3.1.1 ROIs – Region of interest

ROI, also called area-of-interest (AOI) or windowing, allows the user to specify a sub-area of the original sensor size for read-out. ROI can be set by specifying the size (width and height) as well as the position (based on upper left corner) of the sub-area.

3.1.2 Downsampling modes

Downsampling describes the possibility of reducing the image resolution without affecting the sensors physical size, i.e. without reducing the physical size of the sensing area. This feature is useful when optics are used, that are particularly fitted to a certain sensor size and if it is necessary to maintain the full image circle on the sensor.

Downsampling can be achieved in two ways: binning and decimation.

Binning/decimation selector selects which binning/decimation engine is used (Sensor, FPGA, CPU). After setting of selector, multiple parameters could be get or set for the selected unit.

They can be divided into:

- Patterns** define the horizontal/vertical pattern how photo-sensitive cells are combined (mono or bayer)
- Values** reduce the horizontal or vertical resolution of the image by the specified horizontal/vertical downsampling factor
- Modes** in case of binning set the mode used to combine horizontal/vertical photo-sensitive cells together (sum or average)

Binning

When binning is applied, the image is divided into cluster of $k \times l$ pixels, where all pixels in each cluster are interpolated and result in the value of one output pixel. For example, a 2×2 binning produces 2×2 -pixel clusters and results in images with $\frac{1}{4}$ of the original resolution.

Decimation – Skipping

When decimation is chosen, only every n -th pixel is used to create the output image. For example, with a 2×1 vertical skipping, every odd number line is used and every even number line is skipped, resulting in an image with half its original vertical resolution. Skipping is a faster downsampling mode, but also introduces more aliasing effects.

3.1.3 Image data output formats

All modes are provided by the xiAPI or standard interfaces using the xiAPI (please see [Programming](#)). Each camera model supports several Image Data Output Formats.

This table is applicable to:
all models in this manual (refer to the table [Models and sensors overview](#))

Mode	Description
XI_MONO8	8 bits per pixel. [Intensity] ^{1,2}
XI_MONO16	16 bits per pixel. [Intensity LSB] [Intensity MSB] ^{1,2}
XI_RAW8	8 bits per pixel raw data from sensor. [pixel byte] raw data from transport (camera output)
XI_RAW16	16 bits per pixel raw data from sensor. [pixel byte low] [pixel byte high] 16 bits (depacked) raw data
XI_RGB24	RGB data format. [Blue][Green][Red] ¹
XI_RGB32	RGBA data format. [Blue][Green][Red][0] ¹
XI_RGB_PLANAR	RGB planar data format. [Red][Red]...[Green][Green]...[Blue][Blue]... ¹
XI_FRM_TRANSPORT	Data from transport layer (e.g. packed). Depends on data on the transport layer ³

¹Higher CPU processing is required when this mode is selected because color filter array processing is implemented on PC. This processing is serialized when multiple cameras is used at once. The most effective way to get data from camera is to use XI_RAW8, where no additional processing is done in API.

²On monochromatic cameras the black level is not subtracted in XI_MONO8 and XI_MONO16 formats by Image Processing in xiAPI, so black level remains the same as in RAW format.

³When using Transport Data Format, the Image Processing block from XiAPI Image Data Flow is skipped and therefore the Transport format is the most effective data format in terms of CPU and RAM usage.

Table 54: Image data output formats

3.2 Acquisition modes

3.2.1 Free-Run

Also known as continuous acquisition. In this mode the sensor delivers a constant stream of image data at the maximum speed available by the current bandwidth, without any external trigger. Each image exposure is sequentially started automatically when possible.

For all sensors the exposure of the next frame overlaps with the data readout of the previous frame. This Overlap mode gives the highest number of frames per second (FPS).

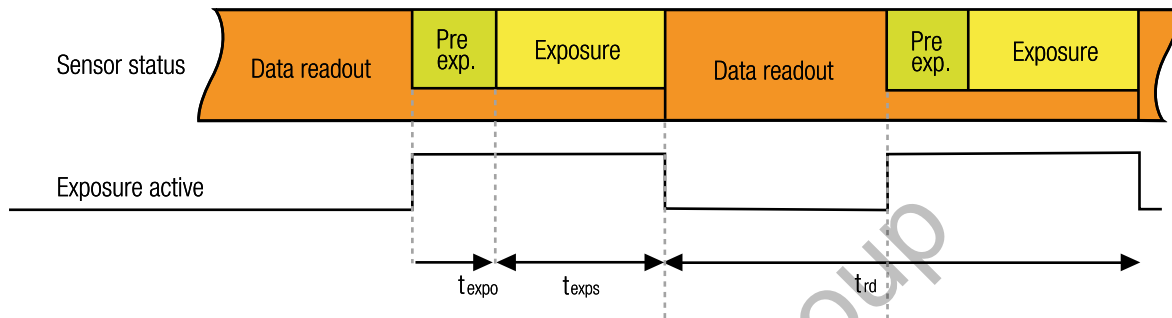

Figure 52: Acquisition mode - free run

The frame rate in free run mode depends inversely on the frame time. In general the frame time roughly equals to the readout time or to the exposure time, depending on which one of the two is larger. This means that when exposure time is larger than the readout time, the frame rate gradually decreases with increasing exposure time ($\text{frame_rate} \sim 1/t_{\text{exp}}$).

In this mode the timing depends on the Exposure Time and Data Readout Time. In situation when the exposure time is comparable or longer than readout time, the exposure active signal might have constant active level during acquisition. This might be caused also by different propagation delay for rising and falling edge of opto isolated outputs. Polarity inversion might help to make visible the separated exposure pulses. Some camera models support limiting of FPS. When set the camera will limit the frame rate so it does not exceed the set value. Please see: [Frame_Rate_Control](#). This is also applicable in case of triggered acquisition.

3.2.2 Trigger controlled acquisition/exposure

Unlike in the free-run, each image exposure can also be triggered with an input trigger signal. In this mode, the sensor waits in stage until the trigger signal arrives. Only then, the exposure of first frame is started, which is followed by the data readout. XIMEA cameras supports several triggered modes along with single image exposure after one trigger. The trigger signal can be either edge sensitive or level sensitive. In the case of "level sensitive", it can be used to control length of exposure or acquisition itself. Generally trigger sources can be divided into two groups:

Software trigger

The trigger signal can be sent to the sensor using a software command. In this case, common system related latencies and jitter apply.

Hardware trigger

A hardware trigger can be sent to the sensor using the digital input. Triggering by hardware is usually used to reduce latencies and jitter in applications that require the most accurate timing. In this case rising edge of input signal is suggested as the delay of opto coupler is smaller as well as introduced jitter. Triggering by hardware is usually used to reduce latencies and jitter in applications that require the most accurate timing.

Triggered mode with overlap

Several sensors are capable to trigger exposure in overlap mode, so it is capable to reach the same frame rate as in free run mode. When the trigger period is longer than the exposure and readout time, the signal wave form will look similar to Triggered mode without overlap. However when the trigger period is decreased, the sensor will expose the images in overlap mode. In this case, the frame active signal will be constantly active.

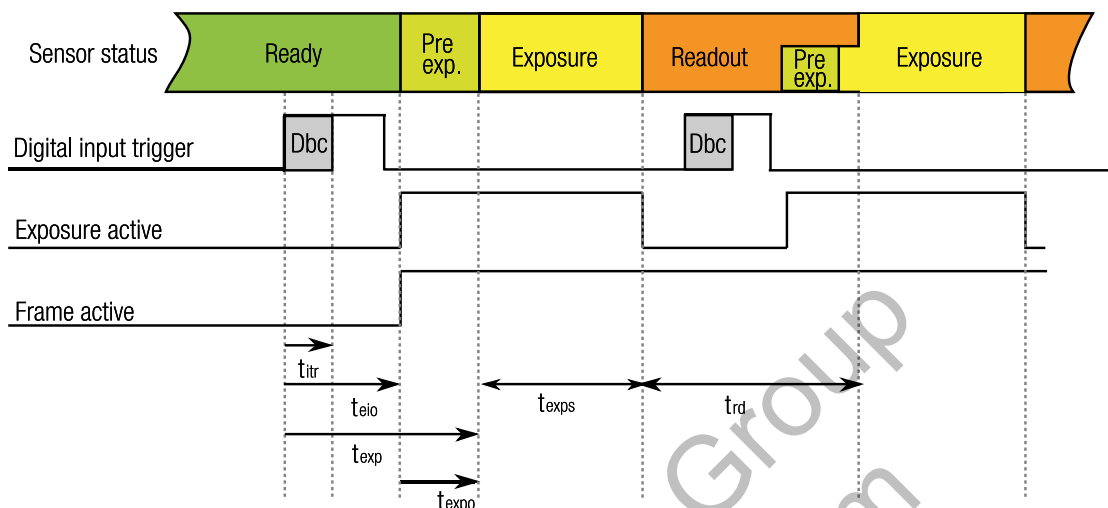

Figure 53: acquisition mode – triggered with overlap

Camera Model	DownS	t_{itr} [μ S]	t_{exp} [μ S]	t_{eio} [μ S]	t_{expo} [μ S]	t_{rd} [μ S]	Notes
MQ042xG-CM	any	1.4	10	11/224	0	$(64.5 + 5.375 \times LC) \times BWF$	N1 ¹ ,N2 ²
MQ022xG-CM	any	1.4	10	11/224	0	$(37.625 + 5.375 \times LC) \times BWF$	N1 ¹ ,N2 ²

¹N1: V(Input)=15 V

²N2: 8bit per pixel maximum bandwidth

Table 55: trigger mode with overlap, timing

- DownS** Current camera DownSampling (XI_PRM_DOWNSAMPLING)
- t_{eio}** Trigger (Digital Input) to Strobe (Digital Output) (on some models is listed: Off->On change / On->Off change)
- t_{exp}** Strobe (Sensor) to Digital Output (on some models is listed: Off->On change / On->Off change)
- t_{expo}** Start of exposition to Exposure Active Digital Output
- LC** Current Line Count (XI_PRM_HEIGHT)
- BW** Bandwidth Factor see table below
- t_{exps}** Current Exposure Time set (XI_PRM_EXPOSURE)
- Conditions** XI_PRM_DEBOUNCE_EN=0 (off)

Bandwidth factor

Bandwidth factor is a number reflecting the ratio between the maximum sensor frequency and the current sensor frequency, calculated from the Bandwidth Limit.

$$BWF = \frac{F_{\max}}{F_{\text{limit}}}$$

Where F_{\max} is maximum possible clock for used sensor in MHz and F_{limit} is used clock depending on Bandwidth Limit parameter set in API (XI_PRM_LIMIT_BANDWIDTH). F_{limit} is set in 1 MHz steps and cannot go lower than F_{\min} .

MQ042xG-CM and MQ022xG-CM

$$F_{\max} = 48 \text{ MHz}$$

$$F_{\min} = 5 \text{ MHz}$$

$$F_{\text{limit}} = \frac{129 \times BW}{8192 \times BPP} \times \frac{12 + LC}{LC} [\text{MHz}]$$

$$t_{\text{rot}} = 64.5 \times BWF \mu\text{s}$$

BPP = number of bytes per pixel

BWL = bandwidth limit in Mbit/s

Minimum trigger period ($t_{\text{trig_min}}$)

Minimum trigger period can be calculated using the following formula:

$$t_{\text{trig_min}} = t_{\text{exp}} + t_{\text{exps}} \text{ (When exposure time is longer than readout time)}$$

$$t_{\text{trig_min}} = t_{\text{rd}} \text{ (When exposure time is significantly shorter than readout time)}$$

$$t_{\text{trig_min}} = t_{\text{exps}} + t_{\text{rot}} \text{ (When exposure is smaller than readout time but the difference is less than } t_{\text{rot}})$$

MQ022MG-CM

$$\text{Exposure time} = 500 \mu\text{s}$$

Image = 2048 px width × 1088 px height with maximum bandwidth and 1 byte per pixel:

$$t_{\text{trig_min}} = 10 \mu\text{s} + (37.625 + 5.375 \times 1088 \text{ lines}) \times 1 = 5895 \mu\text{s}$$

Triggered mode without overlap

This mode gives lower FPS compared to Free-Run mode and lower FPS than Exposure Overlapped with Data Readout mode.

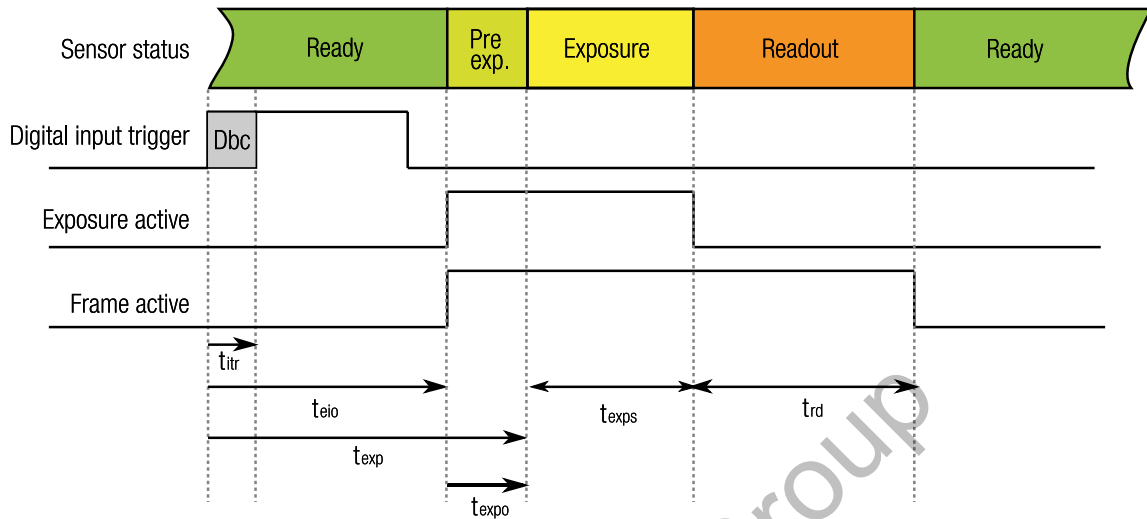

Figure 54: acquisition mode – triggered without overlap

In this mode the timing depends on sum of:

- Input transition time (t_{itr}), depends on:
 - Digital input delay - time for changing internal circuit to active state. It is constant for each camera model.
 - Input debouncing time - time for stabilizing uneven input signals (e.g. from mechanical switches). This time can be set using xiAPI with parameters XI_PRM_DEBOUNCE_EN and XI_PRM_DEBOUNCE_T0 on some cameras. Default 0.
- Exposure time (see ET above)
- Data Readout time (see t_{rd} above)

Typical times for selected camera models

Camera Model	DownS	t_{itr} [μS]	t_{exp} [μS]	t_{eio} [μS]	t_{expo} [μS]	t_{rd} [μS]	Notes
MQ013xG-E2	any	1.4	29	19/238	-10	400 + 16.6 x BWF x LC	N1 ¹ , N2 ²

¹N1: V(Input)=15 V

²N2:x in model name means all available models (M, C, R)

Table 56: trigger mode w/o overlap, timing

- DownS** Current camera DownSampling (XI_PRM_DOWNSAMPLING)
- t_{eio}** Trigger (Digital Input) to Strobe (Digital Output) (on some models is listed: Off->On change / On->Off change)
- t_{exp}** Strobe (Sensor) to Digital Output (on some models is listed: Off->On change / On->Off change)
- t_{expo}** Start of exposition to Exposure Active Digital Output
- LC** Current Line Count (XI_PRM_HEIGHT)
- BW** Bandwidth Factor for maximum bandwidth this is 1 when the bandwidth will be lower BWF will rise
- t_{exps}** Current Exposure Time set (XI_PRM_EXPOSURE)
- Conditions** XI_PRM_DEBOUNCE_EN=0 (off)

Minimum trigger period (T_{trig_min})

Minimum trigger period can be calculated using the following formula:

$$t_{trig_min} = t_{exp} + t_{exps} + t_{rd}$$

MQ013MG-E2

Exposure time = 500 μ s

Image = 500 px width \times 200 px height:

$$t_{trig_min} = 29 \mu\text{s} + 500 \mu\text{s} + 400 \mu\text{s} + 16.6 \mu\text{s} \times 200\text{lines} = 4.249 \text{ ms}$$

Aegis Electronic Group
www.aegiselect.com

Triggered mode - Burst of frames

For more information please see: [Frame Burst Modes](#)

Frame Burst Start

In this mode each trigger pulse triggers defined number of exposed frames.

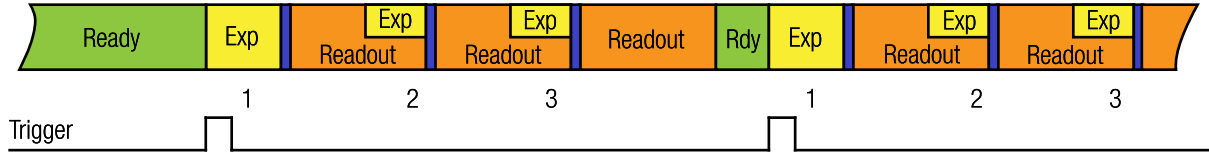

Figure 55: Triggered burst of frames – frame burst start

Frame Burst Active

If trigger is level-sensitive, it can be used to control image acquisition.

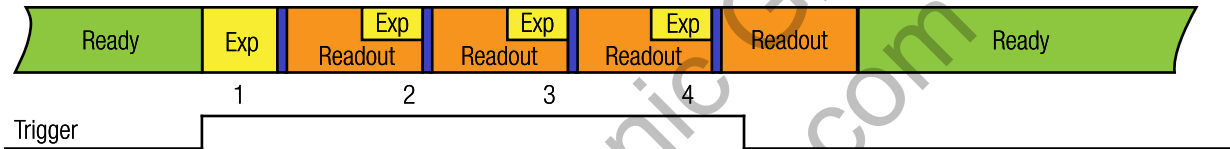

Figure 56: Triggered burst of frames – frame burst active

Triggered mode - Exposure defined by trigger pulse length

In this mode the exposure is defined by trigger pulse length. This can be used to achieve longer exposure than allowed by API. Also, it can be used to trigger several images in sequence with different exposure time. Exposure time is measured and reported in image metadata. Please see: [Exposure Defined by Trigger Pulse Length](#)



Figure 57: Exposure defined by trigger pulse length

3.3 Exposure time

Also known as shutter speed. This parameter defines the length of the integration period for each frame. Most CMOS sensors generate the exposure interval internally. For some it is possible to control it by external signaling. The sensor internal timing depends on the provided system clock. Most sensors use dividers to generate slower clocks for internal usage.

The minimum exposure time is defined mostly by row times, where the row time (T_R) is dependent on various internal settings. Very few sensors support exposure times equal to zero. There is a defined minimum exposure time as well as minimum steps between possible exposure times. There is also a maximum exposure time, defined by sensor architecture.

3.4 Gain

The gain value influences the analog-to-digital conversion process of the image sensor pipeline and acts as a multiplier of the output signal. Using gain values greater than 0 will increase the pixel intensities but may also increase the overall noise level. For some camera models the gain can be set in discrete steps only.

Aegis Electronic Group
www.aegiselect.com

3.5 API Features

Host-assisted image processing features available in xiAPI

3.5.1 Exposure – Auto gain

When AEAG is used, every captured image is evaluated for its mean intensity. Based on the result, the exposure and gain values are modified with the objective to achieve a target intensity level for the following image. Further, the maximum applicable exposure and gain values can be defined. Since both, exposure and gain, have an influence on the intensity, the ratio between those two parameters in their contribution to the algorithm can also be set (exposure priority).

3.5.2 White balance

Only for color models: The white balance can be adjusted with three coefficients kR, kG and kB, one for each color channel. These coefficients can be set individually in order to increase or decrease each channel's contribution and therefore allow the user to control the color tint of the image.

Assisted manual white balance

This feature measures the white balance a single time and sets the white balance coefficient to achieve a mean grey (neutral) tint. The measurement is performed on the central rectangle of the image, with 1/8th of its width and height. The function expects a white sheet of paper exposed to 50% of the intensity values (8 Bit RGB values should be around 128) to be visible.

Auto White Balance

The white balance is measured across the full image for every 4th image that is acquired, and the white balance coefficients are set to achieve a neutral colour tint.

3.5.3 Gamma

Only for color models: As a part of the color filtering process, it is possible to adjust the gamma level of the image. The adjustment can be set separately for the luminosity and the chromaticity.

3.5.4 Sharpness

Only for color models: As a part of the color filtering process, it is possible to adjust the sharpness of the image.

3.5.5 Color correction matrix

The color correction matrix is a 4x4-matrix which is applied on each pixel of an image in a host-assisted post-processing step. This Matrix can be used for example to adjust the brightness, contrast, and saturation.

3.5.6 Sensor defect correction

During the manufacturing process, every camera is tested for various type of defects and a list of the measured defect pixels is created and stored in the camera's non-volatile memory. This list is then used for the correction of acquired images during operation. The correction is inactive by default, but can be turned on by the user if a non-processed output is required.

3.5.7 HDR

Some sensors offer the ability to acquire images with a higher dynamic range than the value presented in the specification. High dynamic range can be achieved by several means as part of the sensor output. The feature supported by some cameras (see ??) is a piecewise linear response, a so-called multiple slope integration.

The dynamic range of a linear image sensor is limited by the saturation of the pixel. Different light intensities are shown in the figure below. All blue marked light intensities cause different signal levels and can be separated without saturation. All red marked intensities cause an overexposure and the info about the different light intensity above 100% is lost.

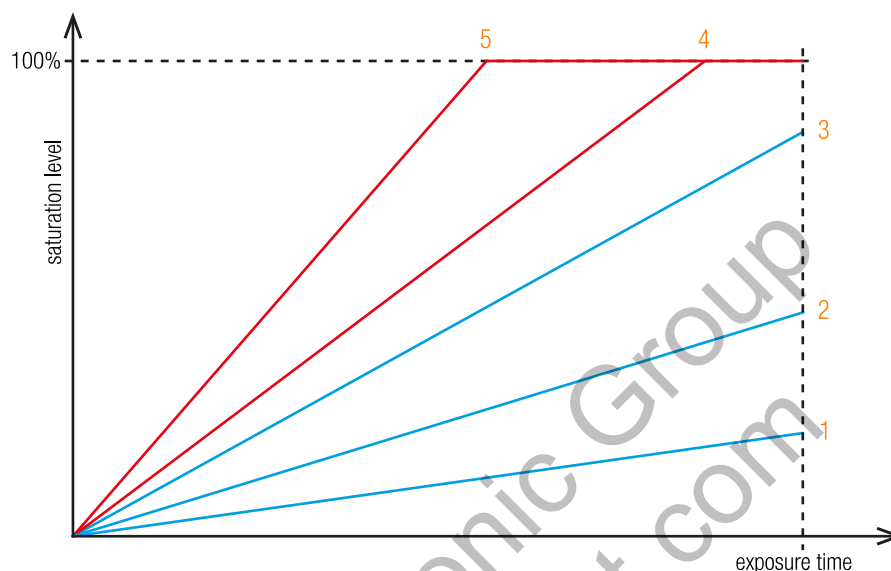

Figure 58: Saturation example without HDR



The dynamic range can be increased by dividing the integration (exposure time) in two or three phases (slopes), with different maximum saturation levels. The camera supports the dividing in three slopes.

To use this kind of HDR method the user has to define two pairs of parameters: (T1, SL1) and (T2, SL2).

- T1 and T2 define portions of the total exposure time and the length of the three timing phases
- SL1 and SL2 define portions of the sensor saturation, so called kneepoint1 and kneepoint2

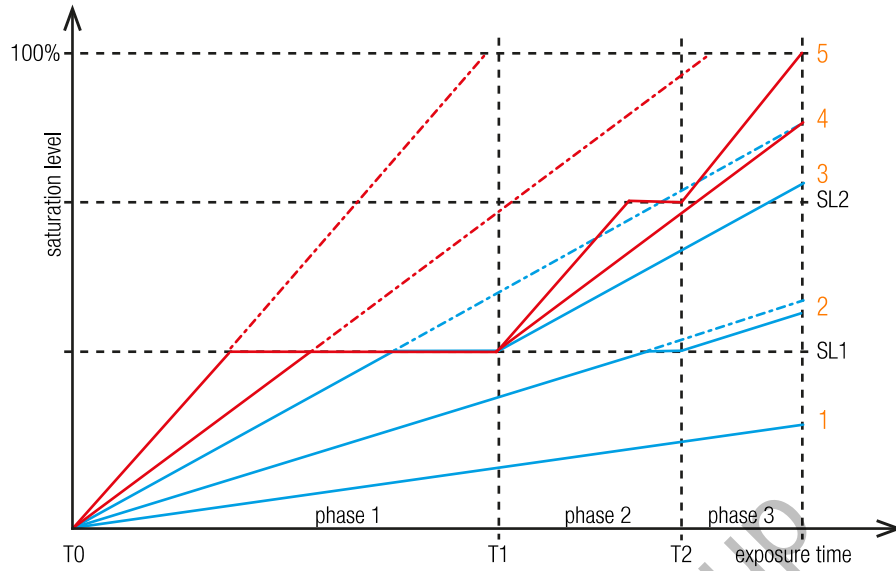

Figure 59: Saturation example with HDR



Description of the multiple slope integration

Phase 1

- All pixels are integrated until they reach the defined saturation level of kneepoint1 (SL1)
- If the saturation level of kneepoint1 is reached, the integration stops. SL1 is the maximum saturation level for all pixels in this phase

Phase 2

- All pixels are integrated until they reach the defined saturation level of kneepoint2 (SL2)
- If the saturation level of kneepoint2 is reached, the integration stops. SL2 is the maximum saturation level for all pixels in this phase

Phase 3

- All pixels are integrated until the exposure time is reached. The pixel saturation may reach the maximum saturation level

The main idea of this method is to reach an approx. logarithmic saturation curve. In order to achieve this goal phase2 always has a smaller slope than phase1 and phase3 smaller than phase 2. Thus, the signal response during phase1 is higher as during phase2. And the signal increase during phase2 is higher than during phase3.

As a result, darker pixels can be integrated during the complete integration time and the full sensor sensitivity can be exploited. Brighter pixels are limited at the knee points and lose a part of their integration time.

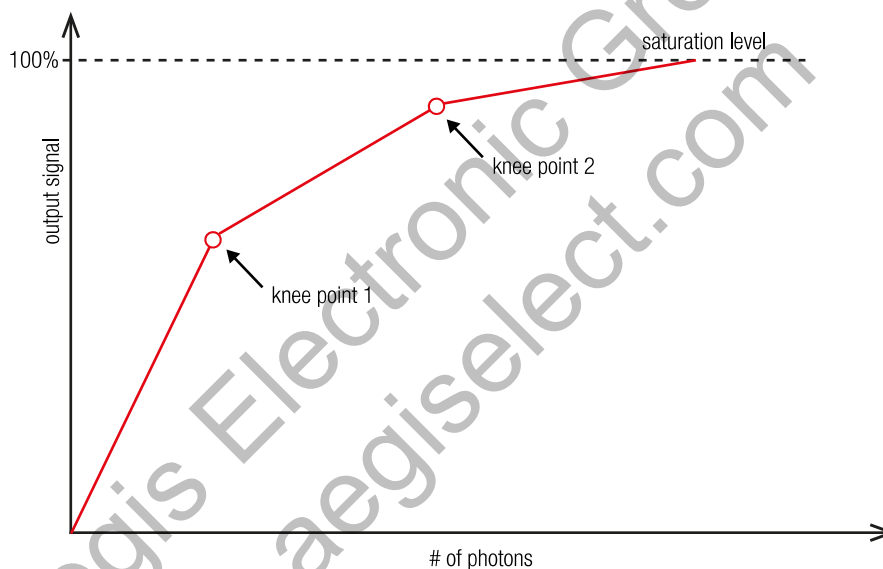

Figure 60: HDR approx logarithmic saturation curve

4 Operation

For a proper operation of your camera there are certain requirements that have to be met. You can read more about these requirements as well as about the correct usage of camera in the following sections.

4.1 System requirements

4.1.1 Software requirements

Cameras are compatible with the following operating systems:

- Windows 10, 11
- Linux Ubuntu
- MacOS 10.8 or newer



macOS

All XIMEA cameras are compatible with the most advanced Vision and Image Processing Libraries. See chapter [XIMEA Software Packages](#) for more information about the options to access cameras, as well as a list of currently supported libraries and frameworks supported in Windows. For more information visit page: [API - Application Programming Interfaces](#)

4.1.2 API Compatibility

S7 camera models achieve full functionality with API version 4.28.01 or higher. Prior to version 4.26.01 (with this version included), they operate identically to their non-S7 counterparts. While compatibility may exist in the intervening API range, certain limitations may arise. To ensure maximum performance, we recommend utilizing API versions 26.01 or earlier and 28.01 or higher.

4.1.3 Hardware requirements

The XIMEA USB3 cameras are compatible with USB 3.1, USB 3.0 and USB 2.0. Please note, that the highest performance can only be achieved by using high performance USB 3.1 or USB 3.0 ports. Using a USB 2.0 port will lead to a limited frame rate.

Please note details and the most recent info at: [Recommended hardware](#)

System configuration

Recommended system configuration:

For best processing performance and bandwidth, we recommend using the following system configuration. This is essential when using the higher resolution models for achieving maximum frame rate.

CPU: Intel i7 or better

RAM: 8GB RAM or more

Disc Space: 400 MB of free disc space

Video: NVIDIA or Radeon graphics card 128MB or integrated on CPU

Ports: Motherboard with a USB 3 port connected to a high performance chipset and/or PCIe x1-16 Gen 2 slot for compatible USB3 host adapter, see [USB 3 host adapters](#).

4.2 XIMEA software packages

4.2.1 XIMEA Windows software package

XIMEA API Software Package can be installed on: Microsoft Windows 10, 11.

Contents

The package contains:

- OS Drivers of all XIMEA camera types for OS Microsoft Windows, Windows Server 2008 R2 x86-64, Windows 10 32/64 bit
- APIs (*xiAPI*, *xiAPI.NET*, *xiApiPython*)
- Examples
- CamTool
- xiCOP
- GenTL Producer - for connection of GenTL Consumer applications
- Vision Libraries integration demonstrations:
 - NI LabView interface - xiLib

Installation

- Download and execute the XIMEA API Software Package installer (EXE-file, approximate size 100 MB): http://www.ximea.com/downloads/recent/XIMEA_Installer.exe
- Read the License Agreement
- Start the installer

Be sure that you have administrator privileges or start the Installer with administrator rights (right click and select “run as administrator”):

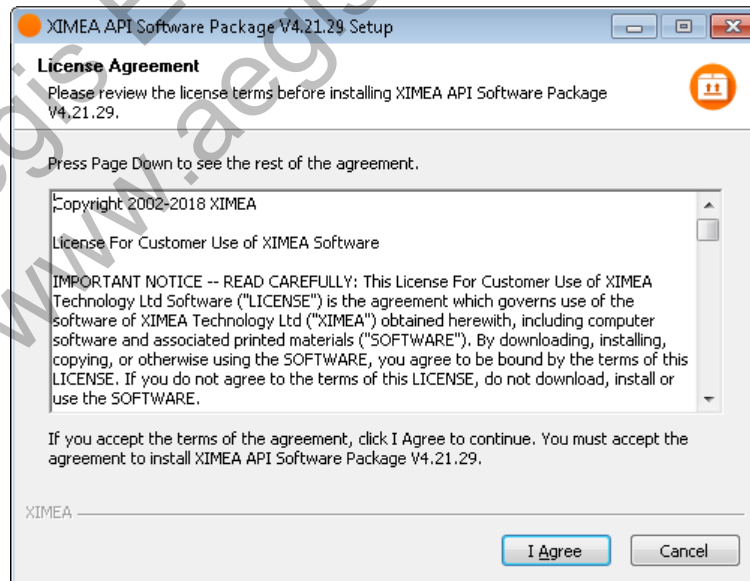

- Select the Software components you want to install. You can uncheck the components you don't want to install, but it is recommended to leave them all checked

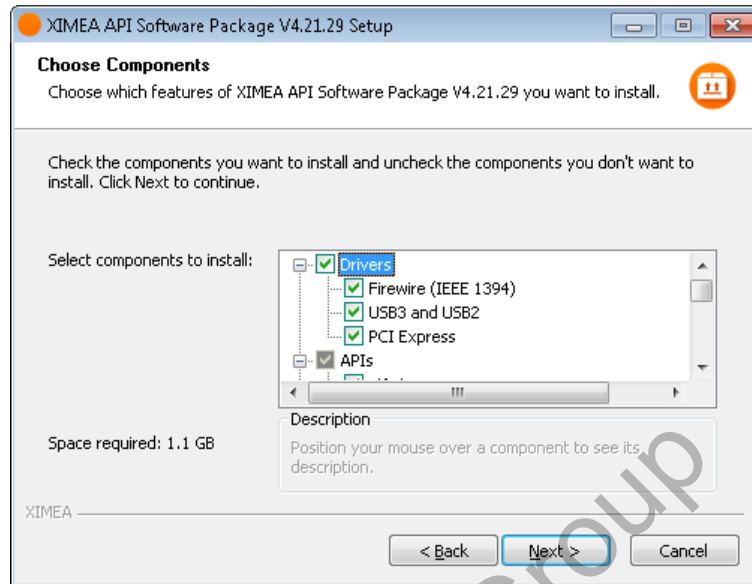

- Specify the install location - you can leave the default location or change it to your desired location

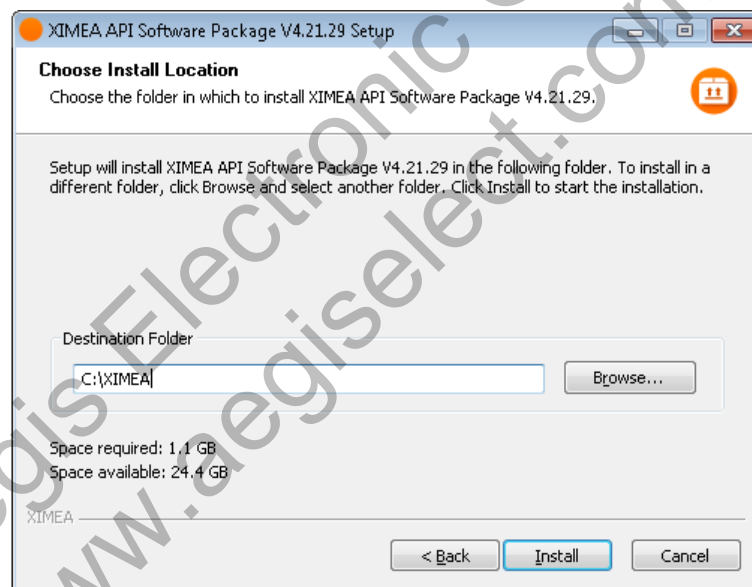

- Now the XIMEA API Software Package should start copying files, updating System Variables and installing drivers if necessary

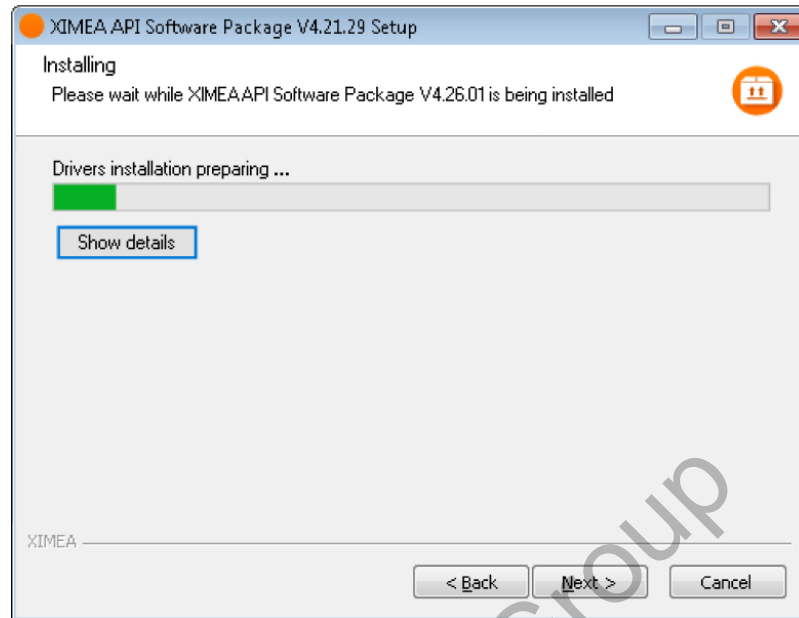

- Installation is completed
- Finish

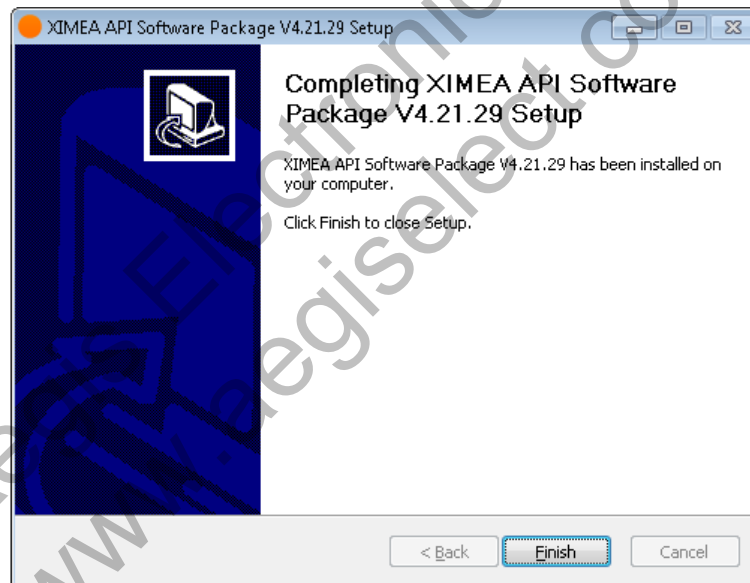

4.2.2 XIMEA Linux software package

XIMEA Linux Software Package is tarred installer with files that can be run on Linux Ubuntu 14.04 and 16.04 (32 and 64 Bit) and newer releases.

Contents

The package contains:

- Driver for XIMEA USB2 and USB3 cameras
- xiAPI
- XIMEA CamTool
- Examples:
 - xiSample - sample showing basic image acquisition in xiAPI

Installation

- Download XIMEA Linux Software Package:

http://www.ximea.com/downloads/recent/XIMEA_Linux_SP.tgz

```
wget http://www.ximea.com/downloads/recent/XIMEA_Linux_SP.tgz
```



```
ximea@ximea-Linux64:~$ wget http://www.ximea.com/downloads/recent/XIMEA_Linux_SP.tgz
--2013-06-05 17:06:29-- http://www.ximea.com/downloads/recent/XIMEA_Linux_SP.tgz
Resolving www.ximea.com (www.ximea.com)... 91.143.80.251
Connecting to www.ximea.com (www.ximea.com)[91.143.80.251]:80... connected.
HTTP request sent, awaiting response... 301 Moved Permanently
Location: http://www.ximea.com/support/attachments/271/XIMEA_Linux_SP.tgz [following]
--2013-06-05 17:06:30-- http://www.ximea.com/support/attachments/271/XIMEA_Linux_SP.tgz
Connecting to www.ximea.com (www.ximea.com)[91.143.80.251]:80... connected.
HTTP request sent, awaiting response... 200 OK
Length: 3885021 (3.7M) [application/octet-stream]
Saving to: 'XIMEA_Linux_SP.tgz'

100%[=====] 3,885,021 2.09M/s in 1.8s

2013-06-05 17:06:31 (2.09 MB/s) - 'XIMEA_Linux_SP.tgz' saved [3885021/3885021]

ximea@ximea-Linux64:~$
```

- Untar

```
tar xzf XIMEA_Linux_SP.tgz
cd package
```

- Start installation script
`./install`

```
ximea@ximea-Linux64: ~/package
ximea@ximea-Linux64:~$ tar xzf XIMEA_Linux_SP.tgz
ximea@ximea-Linux64:~$ cd package
ximea@ximea-Linux64:~/package$ ./install -cam_usb30
This will install XIMEA Linux Package after 5 seconds
To abort installation - press Ctrl-C
Installing x64 bit version
[sudo] password for ximea:
This is installation of package for platform -x64
Checking if user is super user
OK
-----
WARNING!!!
You have enabled experimental USB3 support! It may affect USB2 support too.
DO NOT downgrade the kernel to versions older than 3.4!!!!
Advised way of enabling USB3 support is upgrading kernel to version at least as new as 3.6.
If you decide to do it in the future, rerun this installation script after booting into new k
rnel.
-----
Installing libusb
OK
Installing Firewire support -- libraw1394
OK
Checking Firewire stack
Installing API library
OK
OK
OK
Rebuilding linker cache
Installing XIMEA-GenTL library
OK
Installing vaViewer
OK
Installing streamViewer
OK
Installing xiSample
OK
Creating desktop link for vaViewer
Creating desktop link for streamViewer
Installing udev rules for USB and Firewire cameras
OK
-----
Note:
You may need to reconnect your USB and/or Firewire cameras
Also check that you are in the "plugdev" group
More info:
http://www.ximea.com/support/wiki/apis/Linux_USB20_Support
-----
For GenICam - please add GENICAM_GENTL64_PATH=/opt/XIMEA/lib/libXIMEA_GenTL.so to Your .bashrc
o enable GenTL
Now applications can be started. E.g. /opt/XIMEA/bin/xiSample
-----
Done OK
ximea@ximea-Linux64:~/package$
```

Note: If logged in user is not root, you will be asked for your password to get root access, because the installation runs with root account using sudo.

Aegis Electronic Group
www.aegiselect.com

4.2.3 XIMEA macOS software package

XIMEA macOS Software Package is native DMG installer that can be run on macOS 10.8 (Mountain Lion) or newer.

Contents

The package contains:

- Driver (beta version) for XIMEA USB2 and USB3 cameras
- xiAPI
- XIMEA CamTool
- Examples:
 - xiSample - sample showing basic image acquisition in xiAPI

Installation

Before installing XIMEA macOS Software Package it may be necessary to modify security settings on your computer. The new feature of OS X 10.8 called GateKeeper can prevent you from using our macOS Software Package due to the fact that the current version is unsigned.

- Open System Preferences application and click on Security & Privacy

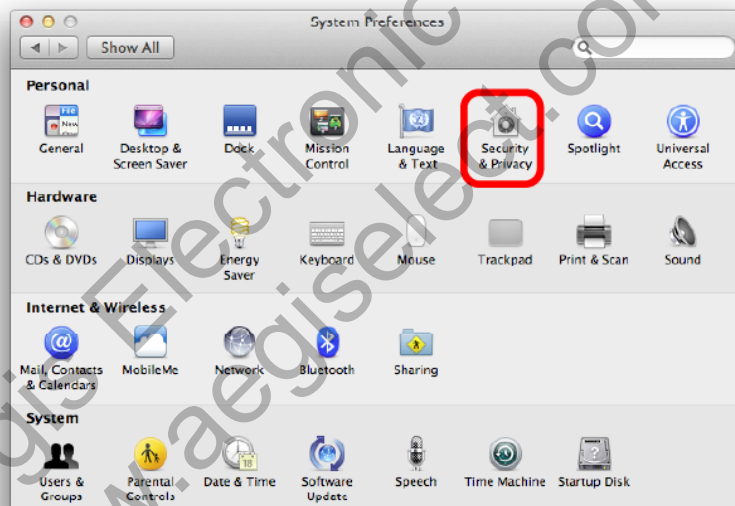

- Click on the lock to allow changes to be made

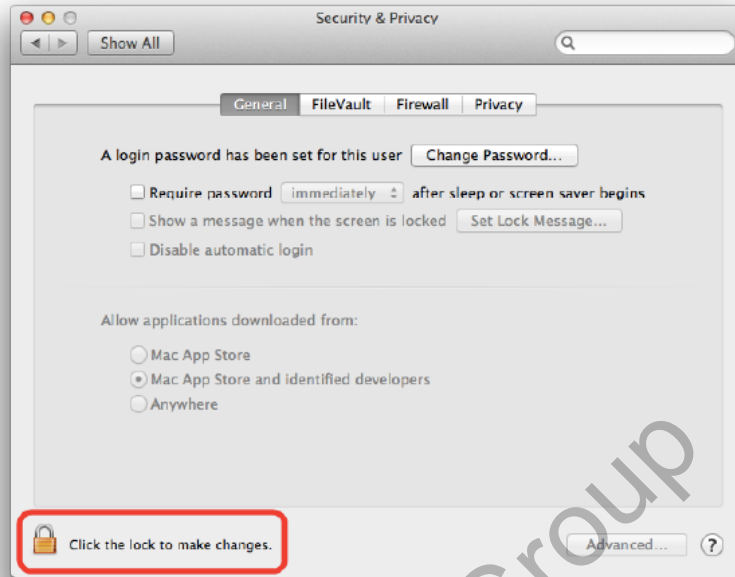

- On the General Tab select the option Anywhere under Allow applications downloaded from:

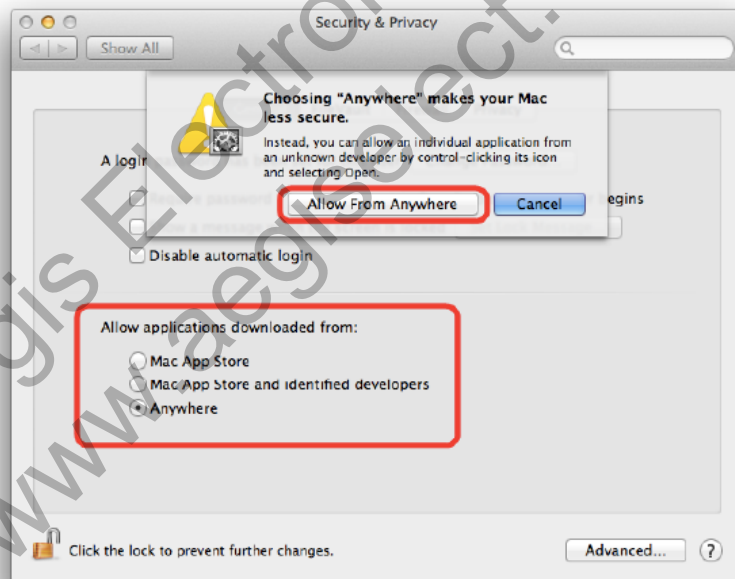

- Download XIMEA macOS Software:
[rhttp://www.ximea.com/downloads/recent/XIMEA_OSX_SP.dmg](http://www.ximea.com/downloads/recent/XIMEA_OSX_SP.dmg)
- Mount it by double-clicking this file in Finder
- Run the install script to install XiAPI on your macOS system
- A window with package contents will open

Start XIMEA CamTool

- Connect camera
- Start Applications / XIMEA CamTool
- Start acquisition by clicking on orange triangle at upper left corner of CamTool



Short description

The CamTool is a cross-platform application showcasing the features of all XIMEA camera families. It runs on Windows, Linux, macOS systems offering a substantial imaging tool set, which can be further extended with custom modules using a plugin infrastructure. CamTool is based on Qt for the UI and xiAPI for the camera control. Its camera settings menu resembles the parameter set of the xiAPI.

Aegis Electronic Group
www.aegiselect.com

4.3 XIMEA CamTool

CamTool allows to operate all connected cameras simultaneously. In this case all controls are layered for the cameras. Basic controls are placed as tabs in upper part of the window. Image window can be detached from application if needed. Amount of visible camera controls depend on visibility level which can be set in Edit → Options. For more information, please, refer to: [CamTool](#)

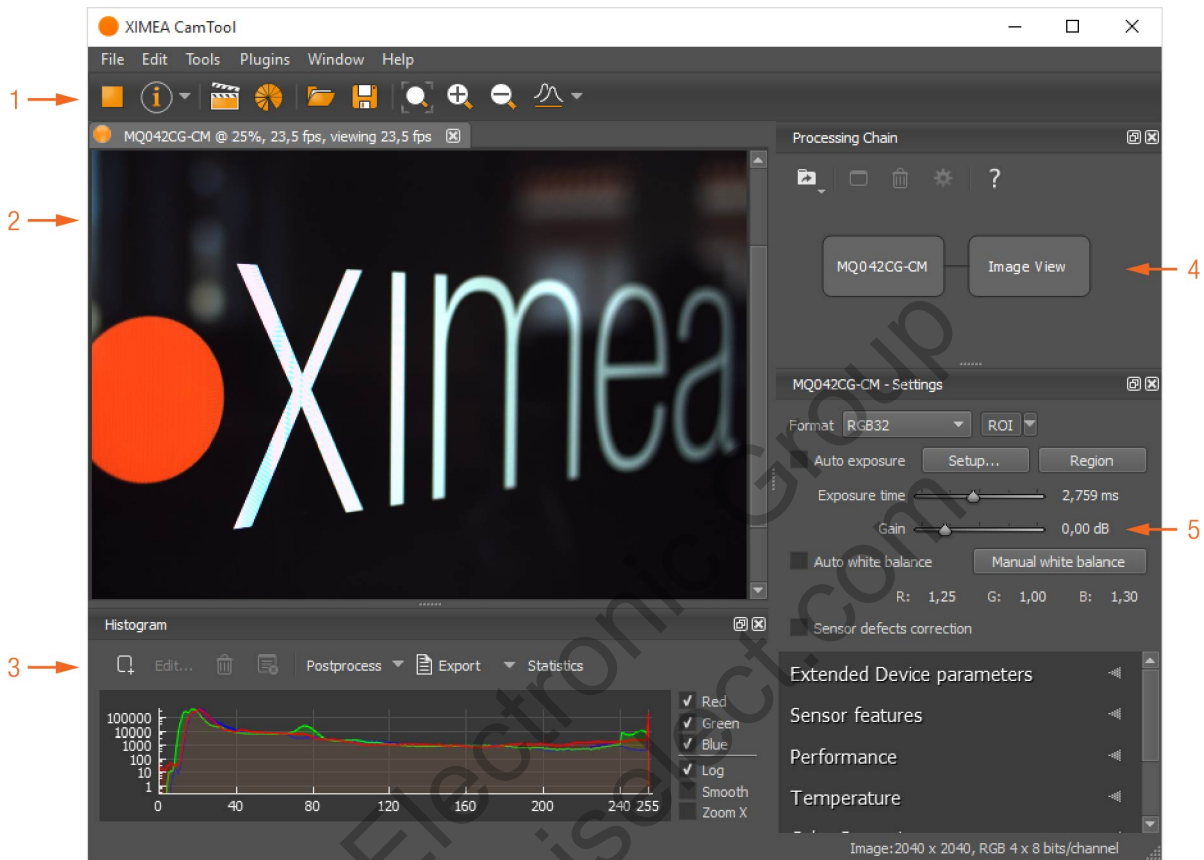

Figure 61: Camtool

Number	1	2	3	4	5
Description	Control panel	Image window	Analytics tools	Processing chain	Camera control

Functions

- To see live image from multiple XIMEA cameras connected
- Control the camera parameters
- Store of camera image and video
- Analyze the image properties
- Histogram and line profile
- Image averaging, image flip/mirror
- Software trigger timer, save/load camera and program settings
- LUT (Look up table)
- Lua scripting

4.4 XIMEA control panel

The XIMEA Control Panel (xiCOP), is a diagnostics and management tool for all XIMEA cameras. xiCOP is available for Windows (32, 64-bit) and Linux (64-bit) operating system.

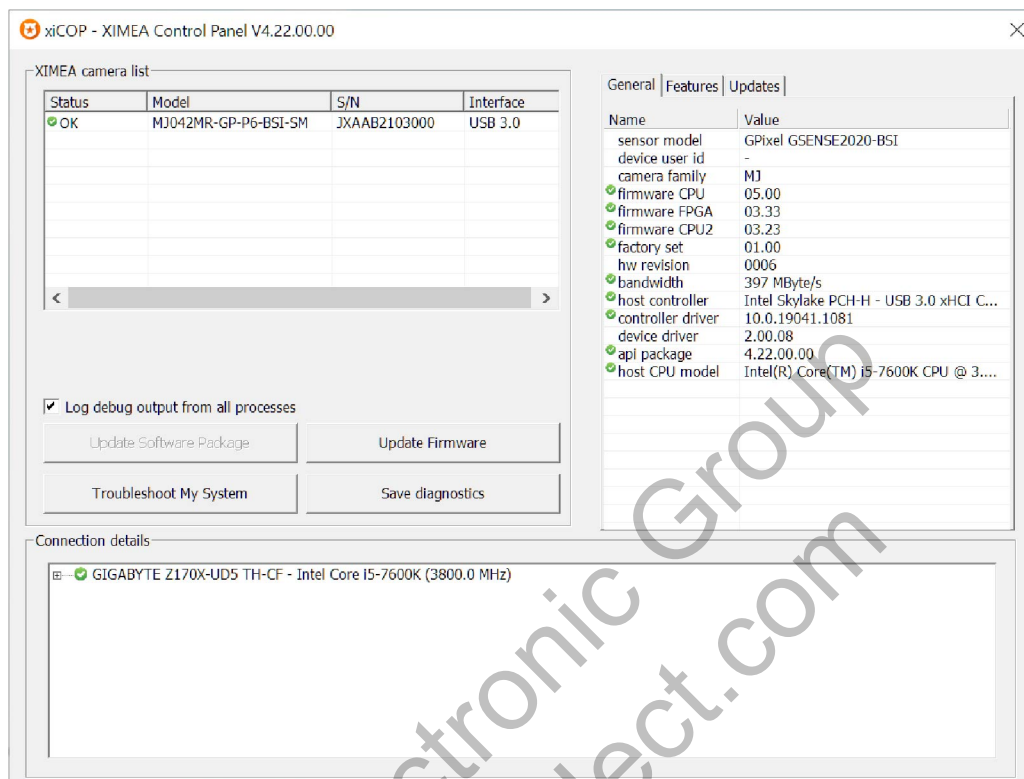

Figure 62: xiCOP example

Features

- Facilitates diagnostics of system performance bottlenecks
xiCOP is capable of retrieving the system's hardware tree, thus problematic hardware configurations can be identified
- Diagnosis of firmware and software compatibility
xiCOP checks relevant firmware and software versions and warns if a component is not up-to-date
- Lists all currently attached XIMEA devices and their features.
- Saves a diagnostic log and debug output which can be reviewed by technical support
- Suggests solution for diagnosed issues
- Allows setting of User IDs to XIMEA cameras
- One click to switch selected XIMEA cameras to USB3 Vision standard and back to XIMEA API
- One click update to the latest XIMEA API Software Package
- One click update of firmware in selected cameras

4.5 Supported vision libraries

All XIMEA cameras are compatible with the most advanced vision and image processing libraries. For GUI based software packages, the cameras can be directly accessed without the need of programming. Code libraries are generally used in conjunction with one of our APIs, in order to add additional functionality (e.g. image processing, communication, data storage).

For an up-to-date listing of the supported vision libraries and software packages, visit our web site:

<http://www.ximea.com/support/projects/vision-libraries/wiki>.

4.5.1 MathWorks MATLAB



MathWorks® is the leading developer and supplier of software for technical computing and Model-Based Design. More: <http://www.mathworks.de/>

https://www.ximea.com/support/wiki/vision-libraries/MathWorks_Matlab

4.5.2 MVTec HALCON



HALCON is the comprehensive standard software for machine vision with an integrated development environment (IDE) that is used world-wide. More: <http://www.mvtec.com/halcon/>

https://www.ximea.com/support/wiki/vision-libraries/MVTec_HALCON

4.5.3 National Instruments LabVIEW vision library



LabVIEW is a graphical programming environment. More: <http://www.ni.com/labview/>

https://www.ximea.com/support/wiki/vision-libraries/National_Instruments_LabVIEW

4.5.4 OpenCV



OpenCV is an open-source library of programming functions mainly aimed at real time computer vision. More: <https://opencv.org/>

<https://www.ximea.com/support/wiki/vision-libraries/OpenCV>

4.6 Programming

Depending on the target application, the user can choose between several ways of accessing and controlling the camera. These can be divided into two categories: a programmatic approach, through programming code, or an integrated approach, through a supported, GUI based software package. The programmatic approach is generally used for the development of a custom application or image processing pipeline. The integrated approach is favored, if the specific toolset of a certain software package is sufficient and the camera serves as an integrated capture device.

4.6.1 Standard interface

As an alternative to the proprietary API, the camera can be accessed through a set of standard interfaces. These interfaces decouple a specific hardware design (e.g. physical interface) of a camera from its control in software. Therefore, multiple camera classes and types can be used in a unified way.

GenICam/GenTL

GenICam/GenTL provides a camera-agnostic transport layer interface to acquire images or other data and to communicate with a device. Each camera serves as a GenTL Producer which can be accessed in all software packages that are compatible with the GenICam standard, as well as through custom developments which implement this standard interface. For more information on programming according to the GenICam standard, please visit the standard's website at <http://www.emva.org/standards-technology/genicam/>

4.6.2 xiAPI

xiAPI stands for XIMEA Application Programming Interface. It is a common interface for all XIMEA cameras.

Architecture

API is a software interface between the camera system driver and application.

- On Windows: xiAPI is compiled into xiapi32.dll or xiapi64.dll
- On Linux: xiAPI is compiled into /usr/lib/libm3api.so

Installation

xiAPI is part of all current XIMEA software packages for Windows, Linux and MacOS. For information on the software packages, see [XIMEA Software Packages](#).

xiAPI functions description

The core of xiAPI consists of the following functions, which allow controlling of the camera functionality.

```
// get the number of discovered devices.
XI_RETURN xiGetNumberDevices(OUT DWORD *pNumberDevices);

// open interface
XI_RETURN xiOpenDevice(IN DWORD DevId, OUT PHANDLE hDevice);

// get parameter
XI_RETURN xiGetParam(IN HANDLE hDevice, const char* prm, void* val,
    DWORD * size, XI_PRM_TYPE * type);

// set parameter
XI_RETURN xiSetParam(IN HANDLE hDevice, const char* prm, void* val,
    DWORD size, XI_PRM_TYPE type);
```

```
// start the data acquisition
XI_RETURN xiStartAcquisition(IN HANDLE hDevice);

// acquire image and return image information
XI_RETURN xiGetImage(IN HANDLE hDevice, IN DWORD TimeOut, INOUT XI_IMG * img);

// stop the data acquisition
XI_RETURN xiStopAcquisition(IN HANDLE hDevice);

// close interface
XI_RETURN xiCloseDevice(IN HANDLE hDevice);
```

xiAPI parameters description

For a complete list of available parameters, please visit the xiAPI online manual at http://www.ximea.com/support/wiki/apis/XiAPI_Manual. All functions in xiAPI return status values in form of the XI_RETURN structure which is defined in xiApi.h. If a parameter is not supported by a certain camera, the return value will represent a respective error code (e.g. 106 - Parameter not supported).

Note: Since xiAPI is a unified programming interface for all of XIMEA's cameras, not all of the described parameters apply for every camera and sensor model.

xiAPI examples

Connect device

This example shows the enumeration of available devices. If any device was found the first device (with index 0) is opened.

```
HANDLE xiH = NULL;

// Get number of camera devices
DWORD dwNumberOfDevices = 0;
xiGetNumberDevices(&dwNumberOfDevices);

if (!dwNumberOfDevices)
{
    printf("No camera found\n");
}
else
{
    // Retrieving a handle to the camera device
    xiOpenDevice(0, &xiH);
}
```

Parameterize device

This example shows how an exposure time is set. Next, the maximum possible downsampling rate is retrieved and the result is set as new downsampling rate.

```
// Setting "exposure" parameter (10ms)
int time_us = 10000;
xiSetParam(xiH, XI_PRM_EXPOSURE, &time_us, sizeof(time_us), xiTypeInteger);

// Getting maximum possible downsampling rate
int dspl_max = 1;
xiGetParamInt(xiH, XI_PRM_DOWNSAMPLING XI_PRM_INFO_MAX, &dspl_max);

// Setting maximum possible downsampling rate
xiSetParamInt(xiH, XI_PRM_DOWNSAMPLING, dspl_max);
```

Acquire images

This example shows how the acquisition is started on the device with the handle xiH, ten images are acquired in a row and the acquisition is stopped.

```

xiStartAcquisition(xiH);

#define EXPECTED_IMAGES 10
for (int images=0;images < EXPECTED_IMAGES;images++)
{
// getting image from camera
xiGetImage(xiH, 5000, &image);
printf("Image %d (%dx%d) received from camera\n", images,
(int)image.width, (int)image.height);
}
xiStopAcquisition(xiH);

```

Hardware trigger and exposure active output

In this setup each image is triggered by a Digital Input Trigger. After the image is triggered, it can be transferred using xiGetImage. This setup ensures a low latency between the trigger signal and image Exposure start.

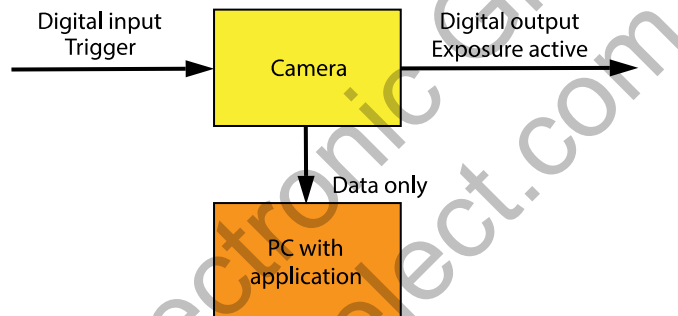

Figure 63: GPIO schematic

```

HANDLE xiH;
xiOpenDevice(0, & xiH);

// select trigger source
xiSetParamInt(xiH, XI_PRM_TRG_SOURCE, XI_TRG_EDGE_RISING);

// select input pin 1 mode
xiSetParamInt(xiH, XI_PRM_GPI_SELECTOR, 1);
xiSetParamInt(xiH, XI_PRM_GPI_MODE, XI_GPI_TRIGGER)

// set digital output 1 mode
xiSetParamInt(xiH, XI_PRM_GPO_SELECTOR, 1);
xiSetParamInt(xiH, XI_PRM_GPO_MODE, XI_GPO_EXPOSURE_ACTIVE);

xiStartAcquisition(handle1);

// Trigger signal should start image exposure within timeout
#define TIMEOUT_IMAGE_WAITING_MS 10000
xiGetImage(handle, TIMEOUT_IMAGE_WAITING_MS, &image);
// process image here...

```

xiAPI Auto Bandwidth Calculation

xiAPI uses Auto Bandwidth Calculation (ABC) before the opening of each camera by default. After the measurement, 90% of the measured value is used as the maximum allowed transfer speed of the camera to ensure the stability of transfer.

It is important to set this parameter to XI_OFF to ensure highest possible data transfer speed.

To disable ABC, the application should set parameter XI_PRM_AUTO_BANDWIDTH_CALCULATION to XI_OFF before the first xiOpenDevice is used. This setting disabled ABC and the camera stream is not limited.

xiAPI.NET

XIMEA Application Programming Interface for Dot Net - Microsoft Visual C#. **xiAPI.NET** is designed as a wrapper around xiAPI and therefore shares most of its functionality.

xiApiPython

Applications in Python can access XIMEA cameras using **xiApiPython** interface. It is a wrapper around xiAPI, which integrates camera features and capabilities into PYTHON.

Aegis Electronic Group
www.aegiselect.com

5 Appendix

5.1 Troubleshooting and support

This chapter explains how to proceed, if you have issues in bringing your camera to proper operation.

At first, please make sure that you have installed the latest version of the following XIMEA software package, based on your OS:

- XIMEA Windows Software Package
https://www.ximea.com/support/wiki/apis/XIMEA_Windows_Software_Package
- XIMEA Linux Software Package
https://www.ximea.com/support/wiki/apis/XIMEA_Linux_Software_Package
- XIMEA macOS Software Package
https://www.ximea.com/support/wiki/apis/XIMEA_macOS_Software_Package

Please make sure, that you have connected your camera with the appropriate XIMEA cable to an appropriate port. Ensure that the connections are carefully locked. Follow the instructions described in section 4.3 (run the camera with the Ximea CamTool). In case that you still have issues, please read the following chapters.

5.1.1 Worldwide support

We offer worldwide first level support to you by our partners. Please refer to your local dealer if you need technical support for your camera.

5.1.2 Before contacting technical support

There are several steps to take before contacting your local dealer for technical support. In case you cannot display images from your camera, please open the XIMEA xiCOP software (please see section 4.4). It will immediately start searching for connected cameras. Your camera will appear in the XIMEA camera list on the upper left side of the xiCOP window if it is connected properly and your USB interface meets the minimum system requirements described in section 4.1. If the camera does not appear, please proceed with the following steps:

- Step 1** Click on the button “Troubleshoot My System” and follow the instructions that are suggested.
- Step 2** If step 1 does not lead to a positive result, please click the button “Save diagnostics”. Keep the diagnostic file ready for providing it to support.
- Step 3** Contact your local dealer where you bought the camera either by phone or by email for first level support. They will decide if they can help you immediately or if more information is necessary for initiating the next steps.

5.2 Frequently Asked Questions

- Frequently Asked Questions
http://www.ximea.com/support/wiki/allprod/Frequently_Asked_Questions
- Knowledge Base
http://www.ximea.com/support/wiki/allprod/Knowledge_Base

5.3 Product service request (PSR)

If you experienced any unexpected behavior of your camera, please, follow the steps described below:

5.3.1 Step 1 – Contact support

If your camera is not working as expected, please, contact your local dealer for troubleshooting the product and determine the eligibility of a Product Service Request (PSR).

In case you were asked to create a PSR by your local contact, please continue to [Step 2](#).

NOTE: Your product must be UNDER WARRANTY in order to qualify for a free repair or replacement.

5.3.2 Step 2 – Create product service request (PSR)

- Read the XIMEA General Terms & Conditions at: <http://www.ximea.com/en/corporate/generaltc>
- Open the XIMEA Helpdesk at: <https://desk.ximea.com/new-ticket>
- Set field Department to “Service”
- Fill in all fields
- Confirm with the button “Submit”

5.3.3 Step 3 – Wait for PSR approval

Our support personnel will verify the PSR for validity.

If your PSR is valid and no further information is required, the PSR will be approved within 3 business days. After that you will get a notification email contains the shipping instructions.

When you received the PSR Approval email – please continue to [Step 4](#).

In case your PSR was rejected – please do not send the product to XIMEA.

5.3.4 Step 4 – Sending the camera to XIMEA

If possible, send the camera back in the original package. If not possible, please pack the camera in a way that it cannot be damaged during shipment and send it back as described in the PSR Approval email that you have received.

5.3.5 Step 5 – Waiting for service conclusion

Once we have received the camera, we will send you a notification. The XIMEA Service will then check the status of the camera that you have sent for a possible repair. Depending on warranty conditions, product status and agreement one of the following operations will be performed:

Operation	Repair costs paid by	Return delivery costs paid by
repaired in warranty	XIMEA	XIMEA
replaced in warranty	XIMEA	XIMEA
repaired for cost	Customer	Customer
not repaired and returned	—	Customer
not repaired and discarded if requested by customer	—	—

Table 57: service operations overview

If the camera will be returned, you will receive the tracking number. In this case, please continue to [Step 6](#).

5.3.6 Step 6 – Waiting for return delivery

After you have received the return shipment, please confirm it by changing the status of the PSR to “Received by customer”.

Aegis Electronic Group
www.aegiselect.com

5.4 Safety instructions and precautions

This chapter describes safety instructions and precautions valid for cameras. In order to avoid harm or damage your camera, please handle it as described in this manual, paying special attention to the following warnings:

5.4.1 Disassembly

There are no switches or parts inside the cameras that requires any kind of mechanical adjustment. Please note that the warranty is voided by opening the camera housing.

Do not disassemble the camera except removing lens mount (or removing cooling element if camera has one), see [Lens mount](#).

5.4.2 Mounting / Screws

Use only the designated threaded holes for mounting the camera. Please note the camera / bracket drawings in chapter [Mechanical characteristics](#).

Use only the specified screws and torques when fastening, see [Mounting points](#).

5.4.3 Connections

Use only recommended connectors and cables. Please check the system requirements described in chapter [System requirements](#).

5.4.4 Power supply

Use only the recommended electrical power supply. Camera can be bus powered or powered from external power supply, for detailed information see section [Power supply](#) .

5.4.5 Environment / protection against water

Use camera in acceptable environment only, please note the descriptions in section [Environment](#). Protect the camera against contact with water. Do not let camera get wet.

Damage may be caused by:

- Overheating
- Contact with water
- Operation in an environment with condensing humidity
- Mechanical shock

5.4.6 Recommended light conditions

Do not expose the camera to light sources with intense energy, e.g. laser beams or X-ray.

Light intensity or exposure time exceeding the saturation of the sensor may damage the sensor irreparably. This may occur e.g. in the following situations:

- High-energy laser light hitting the sensor directly
- Bright light sources hitting the sensor directly (burn-in)
- Camera is exposed to X-rays

The warranty does not cover damaged cameras caused by X-ray applications or very high intensity light / laser light.

5.4.7 Protection of optical components

- Do not touch the optical components with hard or abrasive objects,
- when handling the camera, avoid touching the lenses and filter glasses,
- fingerprints or other impurities may affect the image quality and may damage the surfaces,
- mount / dismount lenses and additional filters only in a dust free environment.
- do not use compressed air as this could push dust into the camera (and lenses).

5.4.8 Mechanical loads

Avoid excessive shaking, throwing, dropping or any kind of mishandling of the device.

5.4.9 Camera / lens cleaning

- Use only optical quality tissue / cloth (dry cotton) a standard camera lens cleaning kit, if you must clean a lens or filter. Do not apply excessive force.
- Use only optics cleaner (e.g. 60 % ethyl alcohol, 40 % ether). Never use aggressive cleaners like gasoline or spirits. Such cleaners may destroy the surface.
- Do not use compressed air.

5.4.10 Protect against static discharge (ESD)

Image sensors and the PCB are easily damaged by static discharge (ESD).

- Please use anti-static gloves, clothes and materials. Also use conductive shoes.
- Wear an ESD protection wrist strap.
- Install a conductive mat on the floor and/or working table to prevent the generation of static electricity.

5.4.11 Safety instruction for board level cameras

Abuse or misapplication of the board level camera may result in limited warranty or cancelation of warranty. Due to the exposed electronics, special rules apply:

- Only qualified personnel are allowed to handle, install and operate the board level cameras.
- Board level cameras are delivered without housing. Handle the PCB and the sensor with care. Do not bend the boards. Do not touch the components or contacts on a board. Hold the board by its edges only.
- Protect the board level camera against static discharge (see **Protect against static discharge (ESD)** discharge (ESD)).
- Do not hold any components of your board level cameras against your clothing, even if you are wearing a wrist strap.
- Do not remove the board level camera from its anti-static packaging unless your body is grounded.
- To protect the boards from radiation of other modules or devices a housing or shielding may be required.
- Be sure that the board level camera has no contact to any electrical source before mounting or making connections to the board level camera.
- Do not connect or disconnect any cables or use the board level camera during an electrical storm.
- Avoid any mechanical forces to the board level cameras, especially torsional, tensile and compressive forces. Any of these forces may result in damage of the board level cameras.
- Always use clean boards.
- To protect the boards from dirt like dust or liquids always use the board level cameras in clean room environment or use a protective housing.

5.5 Warranty

In addition to the provisions of Article VIII of the Standard Terms & Conditions of XIMEA GmbH (see [Standard Terms & Conditions of XIMEA GmbH](#)) the following additions and specifications apply:

XIMEA warrants to the Original Purchaser that the Camera provided is guaranteed to be free from material and manufacturing defects for a period of two years. Should a unit fail during this period, XIMEA will, at its option, repair or replace the damaged unit. Repaired or replaced Products are covered for the remainder of the original Product warranty period.

Warranty is void if any proprietary labeling is removed. This warranty does not apply to units that, after being examined by XIMEA, have been found to have failed due to customer abuse, mishandling, alteration, improper installation or negligence. If the original camera module is housed within a case, removing the case for any purpose voids this warranty. This warranty does not apply to damage to any part of the optical path resulting from removal or replacement of the protective glass or filter over the camera, such as scratched glass or sensor damage. If the camera is disassembled, reworked or repaired by anyone other than a recommended service person, XIMEA or its suppliers will take no responsibility for the subsequent performance or quality of the camera.

XIMEA expressly disclaims and excludes all other warranties, express, implied and statutory, including, but without limitation, warranty of merchantability and fitness for a particular application or purpose. In no event shall XIMEA be liable to the Original Purchaser or any third party for direct, indirect, incidental, consequential, special or accidental damages, including without limitation damages for business interruption, loss of profits, revenue, data or bodily injury or death except in case of willful misconduct by XIMEA or employees of XIMEA.

5.5.1 Disclaimer of Warranty

In addition to the provisions of Article XII of the Standard Terms & Conditions of XIMEA GmbH (see [Standard Terms & Conditions of XIMEA GmbH](#)) the following apply:

Although XIMEA has taken care to ensure the accuracy of the information contained herein it accepts no responsibility for the consequences of any use thereof and also reserves the right to change the specification of goods without notice.

XIMEA does not assume any liability for damage that is the result of improper use of its products or failure to comply with the operating manuals or the applicable rules and regulations.

Aegis Electronic Group
www.aegiselect.com

5.6 Standard Terms & Conditions of XIMEA GmbH

Printed here for your information is the version from May 2021. Please check the most current version at

[XIMEA General Terms and Conditions](#)

General Conditions

for the Supply of Products and Services of the Electrical and Electronics Industry ("Grüne Lieferbedingungen" – GL)*
for commercial transactions between businesses

recommended by ZVEI-Zentralverband Elektrotechnik- und Elektronikindustrie e. V.

as of January 2022 (with 24 months warranty period), and listed below

Article I: General Provisions

1. Legal relations between Supplier and Purchaser in connection with supplies and/or services of the Supplier (hereinafter referred to as "Supplies") shall be solely governed by the present GL. The Purchaser's general terms and conditions shall apply only if expressly accepted by the Supplier in writing. The scope of delivery shall be determined by the congruent mutual written declarations.
2. The Supplier herewith reserves any industrial property rights and/or copyrights and rights of use pertaining to its cost estimates, drawings and other documents (hereinafter referred to as "Documents"). The Documents shall not be made accessible to third parties without the Supplier's prior consent and shall, upon request, be returned without undue delay to the Supplier if the contract is not awarded to the Supplier. Sentences 1 and 2 shall apply mutatis mutandis to the Purchaser's Documents; these may, however, be made accessible to those third parties to whom the Supplier has rightfully subcontracted Supplies.
3. The Purchaser has the non-exclusive right to use standard software and firmware, provided that it remains unchanged, is used within the agreed performance parameters, and on the agreed equipment. Without express agreement the Purchaser may make one back-up copy of standard software.
4. Partial deliveries are allowed, unless they are unreasonable to accept for the Purchaser.
5. The term "claim for damages" used in the present GL also includes claims for indemnification for useless expenditure.

Article II: Prices, Terms of Payment, and Set-Off

1. Prices are ex works and excluding packaging; value added tax shall be added at the then applicable rate.
2. If the Supplier is also responsible for assembly or erection and unless otherwise agreed, the Purchaser shall pay the agreed remuneration and any incidental costs required, e. g. for traveling and transport as well as allowances.
3. Payments shall be made free Supplier's paying office.
4. The Purchaser may set off only those claims which are undisputed or non-appealable.

Article III: Retention of Title

1. The items pertaining to the Supplies ("Retained Goods") for which the purchase price claim is due immediately or for which a payment period of up to and including 30 days after delivery, delivery with installation/assembly or receipt of invoice has been agreed for the due date of the purchase price claim shall remain the property of the Supplier until payment has been made in total.
2. In all other cases, the items pertaining to the Supplies ("Retained Goods") shall remain the Supplier's property until each and every claim the Supplier has against the Purchaser on account of the business relationship has been fulfilled. If the combined value of the Supplier's security interests exceeds the value of all secured claims by more than 20 %, the Supplier shall release a corresponding part of the security interest if so requested by the Purchaser; the Supplier shall be entitled to choose which security interest it wishes to release.
3. For the duration of the retention of title, the Purchaser may not pledge the Retained Goods or use them as security, and resale shall be possible only for resellers in the ordinary course of their business and only on condition that the reseller receives payment from its customer or makes the transfer of property to the customer dependent upon the customer fulfilling its obligation to effect payment.
4. Should Purchaser resell Retained Goods, it assigns to the Supplier, already today, all claims it will have against its customers out of the resale, including any collateral rights and all balance claims, as security, without any subsequent declarations to this effect being necessary. If the Retained Goods are sold on together with other items and no individual price has been agreed with respect to the Retained Goods,

Purchaser shall assign to the Supplier such fraction of the total price claim as is attributable to the price of the Retained Goods invoiced by Supplier.

5. (a) Purchaser may process, amalgamate or combine Retained Goods with other items. Processing is made for Supplier. Purchaser shall store the new item thus created for Supplier, exercising the due care of a diligent business person. The new items are considered as Retained Goods.

(b) Already today, Supplier and Purchaser agree that if Retained Goods are combined or amalgamated with other items that are not the property of Supplier, Supplier shall acquire co-ownership in the new item in proportion of the value of the Retained Goods combined or amalgamated to the other items at the time of combination or amalgamation. In this respect, the new items are considered as Retained Goods.

(c) The provisions on the assignment of claims according to No. 4 above shall also apply to the new item. The assignment, however, shall only apply to the amount corresponding to the value invoiced by Supplier for the Retained Goods that have been processed, combined or amalgamated.

(d) Where Purchaser combines Retained Goods with real estate or movable goods, it shall, without any further declaration being necessary to this effect, also assign to Supplier as security its claim to consideration for the combination, including all collateral rights for the prorate amount of the value the combined Retained Goods have on the other combined items at the time of the combination.

6. Until further notice, Purchaser may collect assigned claims relating to the resale. Supplier is entitled to withdraw Purchaser's permission to collect funds for good reason, including, but not limited to delayed payment, suspension of payments, start of insolvency proceedings, protest or justified indications for overindebtedness or pending insolvency of Purchaser. In addition, Supplier may, upon expiry of an adequate period of notice disclose the assignment, realize the claims assigned and demand that Purchaser informs its customer of the assignment.

7. The Purchaser shall inform the Supplier forthwith of any seizure or other act of intervention by third parties. If a reasonable interest can be proven, Purchaser shall, without undue delay, provide Supplier with the information and/or Documents necessary to assert the claims it has against its customers.

8. Where the Purchaser fails to fulfill its duties, fails to make payment due, or otherwise violates its obligations the Supplier shall be entitled to rescind the contract and take back the Retained Goods in the case of continued failure following expiry of a reasonable remedy period set by the Supplier; the statutory provisions providing that a remedy period is not needed shall be unaffected. The Purchaser shall be obliged to return the Retained Goods. The fact that the Supplier takes back Retained Goods and/or exercises the retention of title, or has the Retained Goods seized, shall not be construed to constitute a rescission of the contract, unless the Supplier so expressly declares.

Article IV: Time for Supplies; Delay

1. Times set for Supplies shall only be binding if all Documents to be furnished by the Purchaser, necessary permits and approvals, especially concerning plans, are received in time and if agreed terms of payment and other obligations of the Purchaser are fulfilled. If these conditions are not fulfilled in time, times set shall be extended reasonably; this shall not apply if the Supplier is responsible for the delay.

2. If non-observance of the times set is due to:

(a) force majeure, such as mobilization, war, terror attacks, rebellion or similar events (e. g. strike or lockout);

(b) virus attacks or other attacks on the Supplier's IT systems occurring despite protective measures were in place that complied with the principles of proper care;

(c) hindrances attributable to German, US or otherwise applicable national, EU or international rules of foreign trade law or to other circumstances for which Supplier is not responsible; or

(d) the fact that Supplier does not receive its own supplies in due time or in due form such times shall be extended accordingly.

3. If the Supplier is responsible for the delay (hereinafter referred to as "Delay") and the Purchaser has demonstrably suffered a loss therefrom, the Purchaser may claim a compensation as liquidated damages of 0.5 % for every completed week of Delay, but in no case more than a total of 5 % of the price of that part of the Supplies which due to the Delay could not be put to the intended use.

4. Purchaser's claims for damages due to delayed Supplies as well as claims for damages in lieu of performance exceeding the limits specified in No. 3 above are excluded in all cases of delayed Supplies, even upon expiry of a time set to the Supplier to effect the Supplies. This shall not apply in cases of liability based on intent, gross negligence, or due to loss of life, bodily injury or damage to health. Rescission of the contract by the Purchaser based on statute is limited to cases where the Supplier is responsible for the delay. The above provisions do not imply a change in the burden of proof to the detriment of the Purchaser.

5. At the Supplier's request, the Purchaser shall declare within a reasonable period of time whether it, due to the delayed Supplies, rescinds the contract or insists on the delivery of the Supplies.

6. If dispatch or delivery, due to Purchaser's request, is delayed by more than one month after notification of the readiness for dispatch was given, the Purchaser may be charged, for every additional month commenced, storage costs of 0.5 % of the price of the items of the Supplies, but in no case more than a total of 5 %. The parties to the contract may prove that higher or, as the case may be, lower storage costs have been incurred.

Article V: Passing of Risk

1. Even where delivery has been agreed freight free, the risk shall pass to the Purchaser as follows:

(a) if the delivery does not include assembly or erection, at the time when it is shipped or picked up by the carrier. Upon the Purchaser's request, the Supplier shall insure the delivery against the usual risks of transport at the Purchaser's expense;

(b) if the delivery includes assembly or erection, at the day of taking over in the Purchaser's own works or, if so agreed, after a successful trial run.

2. The risk shall pass to the Purchaser if dispatch, delivery, the start or performance of assembly or erection, the taking over in the Purchaser's own works, or the trial run is delayed for reasons for which the Purchaser is responsible or if the Purchaser has otherwise failed to accept the Supplies.

Article VI: Assembly and Erection

Unless otherwise agreed in written form, assembly and erection shall be subject to the following provisions:

1. Purchaser shall provide at its own expense and in due time:

(a) all earth and construction work and other ancillary work outside the Supplier's scope, including the necessary skilled and unskilled labor, construction materials and tools;

(b) the equipment and materials necessary for assembly and commissioning such as scaffolds, lifting equipment and other devices as well as fuels and lubricants;

(c) energy and water at the point of use including connections, heating and lighting;

(d) suitable dry and lockable rooms of sufficient size adjacent to the site for the storage of machine parts, apparatus, materials, tools, etc. and adequate working and recreation rooms for the erection personnel, including sanitary facilities as are appropriate in the specific circumstances; furthermore, the Purchaser shall take all measures it would take for the protection of its own possessions to protect the possessions of the Supplier and of the erection personnel at the site;

(e) protective clothing and protective devices needed due to particular conditions prevailing on the specific site.

2. Before the erection work starts, the Purchaser shall unsolicitedly make available any information required concerning the location of concealed electric power, gas and water lines or of similar installations as well as the necessary structural data.

3. Prior to assembly or erection, the materials and equipment necessary for the work to start must be available on the site of assembly or erection and any preparatory work must have advanced to such a degree that assembly or erection can be started as agreed and carried out without interruption. Access roads and the site of assembly or erection must be level and clear.

4. If assembly, erection or commissioning is delayed due to circumstances for which the Supplier is not responsible, the Purchaser shall bear the reasonable costs incurred for idle times and any additional traveling expenditure of the Supplier or the erection personnel.

5. The Purchaser shall attest to the hours worked by the erection personnel towards the Supplier at weekly intervals and the Purchaser shall immediately confirm in written form if assembly, erection or commissioning has been completed.

6. If, after completion, the Supplier demands acceptance of the Supplies, the Purchaser shall comply therewith within a period of two weeks. The same consequences as upon acceptance arise if and when the Purchaser lets the two-week period expire or the Supplies are put to use after completion of agreed test phases, if any.

Article VII: Receiving Supplies

The Purchaser shall not refuse to receive Supplies due to minor defects.

Article VIII: Defects as to Quality

The Supplier shall be liable for defects as to quality (“Sachmängel”, hereinafter referred to as “Defects”), as follows:

1. The Supplies are free from Defects if upon the passing of the risk they comply with the subjective requirements, the objective requirements and the installation requirements pursuant to Sec. 434 German Civil Code (“Bürgerliches Gesetzbuch”). 2 If the parties have agreed on the quality of the Supplies (“Beschaffensvereinbarung”), the question whether the Supplies meet the objective requirements shall be determined exclusively by such agreement. 3 Sentence 2 shall not apply if the last contract in the supply chain is a sale of consumer goods.

2. Defective parts or defective services shall be, at the Supplier’s discretion, repaired, replaced or provided again free of charge, provided that the reason for the Defect had already existed at the time when the risk passed.

3. Claims for repair or replacement are subject to a statute of limitations of 24 months calculated from the start of the statutory statute of limitations; the same shall apply mutatis mutandis in the case of rescission and reduction. This shall not apply: - where longer periods are prescribed by law according to Sec. 438 para. 1 No. 2 (buildings and things used for a building), and Sec. 634a para. 1 No. 2 (defects of a building) German Civil Code (“Bürgerliches Gesetzbuch”),

- in the case of intent,
- in the case of fraudulent concealment of the Defect or
- non-compliance with guaranteed characteristic (“Beschaffensgarantie”).

Claims for the reimbursement of expenses on the part of the Purchaser in accordance with Sec. 445a BGB (entrepreneur’s right of recourse) shall likewise be subject to a statute of limitations of 24 months from the start of the statutory statute of limitations, provided the last contract in the supply chain is not a sale of consumer goods.

4. The legal provisions regarding suspension of the statute of limitations (“Ablaufhemmung”, “Hemmung”) and recommencement of limitation periods shall be unaffected. The suspension of the statute of limitations according to Sec. 445b para. 2 BGB (limitation of right of recourse) shall in any case end no later than 5 years after the date on which the Supplier delivered the concerned item to the seller. This shall not apply if the last contract in the supply chain is a sale of consumer goods or in cases that are according to No. 3 Sentence 2 above.

5. Notifications of Defect by the Purchaser shall be given in written form without undue delay.

6. In the case of claims for Defects, the Purchaser may withhold payments to an amount that is in a reasonable proportion to the Defect. The Purchaser has no right to withhold payments to the extent that its claim of a Defect is time-barred. Unjustified notifications of Defect shall entitle the Supplier to demand reimbursement of its expenses by the Purchaser.

7. The Supplier shall be given the opportunity to repair or to replace the defective good (“Nacherfüllung”) within a reasonable period of time.

8. If repair or replacement is unsuccessful, the Purchaser is entitled to rescind the contract or reduce the remuneration; any claims for damages the Purchaser may have according to No. 10 shall be unaffected.

9. There shall be no claims based on Defect in cases of insignificant deviations from the agreed quality, of only minor impairment of usability, of natural wear and tear, or damage arising after the passing of risk from faulty or negligent handling, excessive strain, unsuitable equipment, defective civil works, inappropriate foundation soil, or claims based on particular external influences not assumed under the contract, or from non-reproducible software errors. Claims based on defects attributable to improper modifications, installation/ removal, or repair work carried out by the Purchaser, or third parties and the consequences thereof are likewise excluded.

10. The Purchaser shall have no claim with respect to expenses incurred in the course of supplementary performance, to the extent that expenses are increased because the subjectmatter of the Supplies has subsequently been brought to another location than the Purchaser’s branch office, unless doing so complies with the normal use of the Supplies. This applies accordingly to claims for the reimbursement of expenses on the part of the Purchaser in accordance with Sec. 445a BGB (entrepreneur’s right of recourse), provided the last contract in the supply chain is not a sale of consumer goods.

11. The Purchaser’s right of recourse against the Supplier pursuant Sec. 445a BGB (entrepreneur’s right of recourse) is limited to cases where the Purchaser has not concluded an agreement with its customers exceeding the scope of the statutory provisions governing claims based on Defects.

12. The Purchaser shall have no claim for damages based on Defects. This shall not apply to the extent that a Defect has been fraudulently concealed, the guaranteed characteristics are not complied with, in the case of loss of life, bodily injury or damage to health, and/or intentionally or grossly negligent breach of contract on the part of the Supplier. The above provisions do not imply a change in the burden of proof to the detriment of the Purchaser. Any other or additional claims of the Purchaser exceeding the claims provided for in this Article VIII, based on a Defect, are excluded.

Article IX: Industrial Property Rights and Copyrights; Defects in Title

1. Unless otherwise agreed, the Supplier shall provide the Supplies in the country of the place of delivery only, without infringing any third-party industrial property rights and copyrights (hereinafter referred to as "IPR"). If a third party asserts a justified claim against the Purchaser based on an infringement of an IPR by the Supplies made by the Supplier and used in conformity with the contract, the Supplier shall be liable to the Purchaser within the time period stipulated in Article VIII No. 2 as follows:

(a) The Supplier shall choose whether to acquire, at its own expense, the right to use the IPR with respect to the Supplies concerned or whether to modify the Supplies such that they no longer infringe the IPR or replace them. If this would be impossible for the Supplier under reasonable conditions, the Purchaser may rescind the contract or reduce the remuneration pursuant to the applicable statutory provisions;

(b) The Supplier's liability to pay damages is governed by Article XII;

(c) The above obligations of the Supplier shall apply only if the Purchaser (i) immediately notifies the Supplier of any such claim asserted by the third party in written form, (ii) does not concede the existence of an infringement and (iii) leaves any protective measures and settlement negotiations to the Supplier's discretion. If the Purchaser stops using the Supplies in order to reduce the damage or for other good reason, it shall be obliged to point out to the third party that no acknowledgement of the alleged infringement may be inferred from the fact that the use has been discontinued.

2. Claims of the Purchaser shall be excluded if it is responsible for the infringement of an IPR.

3. Claims of the Purchaser are also excluded if the infringement of the IPR is caused by specifications made by the Purchaser, by a type of use not foreseeable by the Supplier or by the Supplies being modified by the Purchaser or being used together with products not provided by the Supplier.

4. In addition, with respect to claims by the Purchaser pursuant to No. 1 a) above, Article VIII Nos. 4, 5, 8, and 9 shall apply mutatis mutandis in the event of an infringement of an IPR.

5. Where other defects in title occur, Article VIII shall apply mutatis mutandis.

6. Any other claims of the Purchaser against the Supplier or its agents or any such claims exceeding the claims provided for in this Article IX, based on a defect in title, are excluded.

Article X: Conditional Performance

1. The performance of this contract is conditional upon that no hindrances attributable to German, US or otherwise applicable national, EU or international rules of foreign trade law or any embargos or other sanctions exist.

2. The Purchaser shall provide any information and Documents required for export, transport and import purposes.

Article XI: Impossibility of Performance; Adaptation of Contract

1. To the extent that delivery is impossible, the Purchaser is entitled to claim damages, unless the Supplier is not responsible for the impossibility. The Purchaser's claim for damages is, however, limited to an amount of 10 % of the value of the part of the Supplies which, owing to the impossibility, cannot be put to the intended use. This limitation shall not apply in the case of liability based on intent, gross negligence or loss of life, bodily injury or damage to health; this does not imply a change in the burden of proof to the detriment of the Purchaser. The Purchaser's right to rescind the contract shall be unaffected.

2. Where events within the meaning of Article IV No. 2 (a) to (c) substantially change the economic importance or the contents of the Supplies or considerably affect the Supplier's business, the contract shall be adapted taking into account the principles of reasonableness and good faith. To the extent this is not justifiable for economic reasons, the Supplier shall have the right to rescind the contract. The same applies if required export permits are not granted or cannot be used. If the Supplier intends to exercise its right to rescind the contract, it shall notify the Purchaser thereof without undue delay after having realized the repercussions of the event; this shall also apply even where an extension of the delivery period has previously been agreed with the Purchaser.

Article XII: Other Claims for Damages

1. Unless otherwise provided for in the present GL, the Purchaser has no claim for damages based on whatever legal reason, including infringement of duties arising in connection with the contract or tort.

2. This does not apply if liability is based on:

- (a) the German Product Liability Act (“Produkthaftungsgesetz”);
- (b) intent;
- (c) gross negligence on the part of the owners, legal representatives or executives;
- (d) fraud;
- (e) failure to comply with a guarantee granted;
- (f) negligent injury to life, limb or health; or
- (g) negligent breach of a fundamental condition of contract (“wesentliche Vertragspflichten”).

However, claims for damages arising from a breach of a fundamental condition of contract shall be limited to the foreseeable damage which is intrinsic to the contract, provided that no other of the above case applies.

3. The above provision does not imply a change in the burden of proof to the detriment of the Purchaser.

Article XIII: Venue and Applicable law

1. If the Purchaser is a businessman, sole venue for all disputes arising directly or indirectly out of the contract shall be the Supplier’s place of business. However, the Supplier may also bring an action at the Purchaser’s place of business.
2. This contract and its interpretation shall be governed by German law, to the exclusion of the United Nations Convention on contracts for the International Sale of Goods (CISG).

Article XIV: Severability Clause

The legal invalidity of one or more provisions of this Agreement in no way affects the validity of the remaining provisions. This shall not apply if it would be unreasonably onerous for one of the parties to be obligated to continue the contract.

Aegis Electronic Group
www.aegiselect.com

5.7 List of Trademarks

XIMEA, xiC, xiQ, xiMU, xiB, xiB-64, xiX, xiX-XL, xiX-Xtreme, xSWITCH, xPLATFORM, xEC, xEC2, xiCool, xiRAY, xiCe, xiSpec, xiFLY, xiD, xiJ, xiLAB, xiAPI, xiCamTool, xiCOP and CURRERA are trademarks or registered trademarks of XIMEA GmbH in Germany, Slovakia, USA and other countries.

Microsoft, Windows are either registered trademarks or trademarks of Microsoft Corporation in the United States and/or other countries.

Apple, the Apple logo, Macintosh, MacOS, OS X, Bonjour, the Bonjour logo and the Bonjour symbol are trademarks of Apple Computer, Inc.

Linux is a trademark of Linus Torvalds. The USB3 Vision is trademark owned by the AIA.

All other brands, service provision brands and logos referred to are brands, service provision brands and logos belonging to their respective owners.

5.8 Copyright

All texts, pictures and graphics are protected by copyright and other laws protecting intellectual property. It is not permitted to copy or modify them for trade use or transfer, nor may they be used on websites.

Aegis Electronic Group
www.aegiselect.com

Glossary

- API** Application Programming Interface 71
- CMOS** Complementary Metal-Oxide-Semiconductor 72
- ESD** Electrostatic discharge 7, 47, 97
- FPGA** Field Programmable Gate Array 64
- FPS** Frame Per Second 66
- PCB** Printed Circuit Board (same as PWB) 97
- PSR** Product Service Request 7, 94, 95
- ROI** Region Of Interest 64

Aegis Electronic Group
www.aegiselect.com

List of Figures

1	Standard conformity CE logo	3
2	Standard conformity UKCA logo	3
3	Standard conformity FCC logo	3
4	Standard conformity RoHS logo	4
5	Standard conformity WEEE logo	4
6	Lens mount adapter C/CS-mount	17
7	xiC camera mounting points	18
8	M2 mounting screws	18
9	Cross section of MQ013xG-E2-S7 camera models	19
10	Cross section of MQ013xG-ON-S7 camera models	20
11	Cross section of MQ022/042xG-CM-S7 camera models	20
12	Filter glass BK7 AR2x Transmission Curve	21
13	Filter glass ICR650 Transmission Curve	22
14	Graph quantum efficiency of E2V EV76C560	33
15	Graph quantum efficiency of E2V EV76C661	33
16	Graph quantum efficiency of OnSemi PYTHON1300	34
17	Graph quantum efficiency of CMOSIS CMV2000	34
18	Graph quantum efficiency of CMOSIS CMV4000	35
19	Dimensional drawing of MQ013xG-E2-S7	38
20	Dimensional drawing of MQ013xG-E2-FV	39
21	Dimensional drawing of MQ013xG-E2-S7-NIO	40
22	Dimensional drawing of MQ013xG-ON-S7	41
23	Dimensional drawing of MQ013xG-E2-FL	42
24	Dimensional drawing of MQ022/042xG-CM-S7	43
25	Dimensional drawing of MQ022xG-CM-FL	44
26	Dimensional drawing of MQ022/042xG-CM-S7-NIO	45
27	Position of LEDs on xiQ-S7 camera	46
28	USB Micro-B connector location	47
29	USB Micro-B connector pinning	47
30	Flex connector location	49
31	IO connector location	50
32	IO connector pinning	50
33	Flex / IO connector pinning	51
34	Digital input, interface schematic	52
35	Digital output, interface schematic	54
36	USB type-C cable	55
37	wiring USB3 cable	55
38	USB3 cable angled	56
39	wiring USB3 cable	56
40	CBL-MQ-FL-xM	58
41	CBL-MQ-FL-xM zoom	58
42	CBL-USB3FLEX-xM	58
43	CBL-S-M5-3P-PT-xM	59
44	CBL-S-M5-3P-PT-xM pinout	59
45	CBL-S-PB3-PT-OM30	60
46	board-level camera - connector location	60
47	BOB-MQ-FL dimensions	61
48	BOB-MQ-FL dimensions	61
49	MQ-BRACKET-T	62
50	MQ-BRACKET-T dimensional drawing	62
51	MQ-BRACKET-T thick dimensional drawing	62
52	Acquisition mode - free run	66
53	acquisition mode – triggered with overlap	67
54	acquisition mode – triggered without overlap	69
55	Triggered burst of frames – frame burst start	71
56	Triggered burst of frames – frame burst active	71

57	Exposure defined by trigger pulse length	71
58	Saturation example without HDR	74
59	Saturation example with HDR	75
60	HDR approx logarithmic saturation curve	76
61	Camtool	86
62	xiCOP example.....	87
63	GPIO schematic.....	91

Aegis Electronic Group
www.aegiselect.com

List of Tables

1	List of camera models and their respective sensor models and filters	12
2	list of accessories available for xiC cameras	13
3	Power consumption of: MQ013CG-E2-S7, MQ013MG-E2-S7, MQ013RG-E2-S7, MQ013CG-E2-S7-FL, MQ013CG-E2-S7-FV, MQ013MG-E2-S7-FV, MQ013RG-E2-S7-FL, MQ013RG-E2-S7-FV, MQ013MG-E2-S7-FL, MQ013MG-E2-S7-NIO, MQ013CG-E2-S7-NIO and MQ013RG-E2-S7-NIO	14
4	Power consumption of: MQ013CG-ON-S7, MQ013MG-ON-S7 and MQ013RG-ON-S7	14
5	Power consumption of: MQ022RG-CM-S7, MQ022CG-CM-S7, MQ022MG-CM-S7, MQ022CG-CM-S7-FL, MQ022RG-CM-S7-FL, MQ022MG-CM-S7-FL, MQ042CG-CM-S7, MQ042RG-CM-S7, MQ042MG-CM-S7, MQ042CG-CM-S7-FL, MQ042MG-CM-S7-FL and MQ042MG-CM-S7-NIO	14
6	Environment	16
7	M2 screw description	18
8	BK7 filter window parameter	21
9	IR650 filter window parameter	22
10	Sensor parameters of: MQ013CG-E2-S7, MQ013MG-E2-S7, MQ013RG-E2-S7, MQ013CG-E2-S7-FL, MQ013CG-E2-S7-FV, MQ013MG-E2-S7-FV, MQ013RG-E2-S7-FL, MQ013RG-E2-S7-FV, MQ013MG-E2-S7-FL, MQ013MG-E2-S7-NIO, MQ013CG-E2-S7-NIO and MQ013RG-E2-S7-NIO	23
11	Sensor parameters of: MQ013CG-ON-S7, MQ013MG-ON-S7 and MQ013RG-ON-S7	23
12	Sensor parameters of: MQ022RG-CM-S7, MQ022CG-CM-S7, MQ022MG-CM-S7, MQ022CG-CM-S7-FL, MQ022RG-CM-S7-FL and MQ022MG-CM-S7-FL	23
13	Sensor parameters of: MQ042CG-CM-S7, MQ042RG-CM-S7, MQ042MG-CM-S7, MQ042CG-CM-S7-FL, MQ042MG-CM-S7-FL and MQ042MG-CM-S7-NIO	24
14	Image quality parameters of: MQ013CG-E2-S7, MQ013CG-E2-S7-FL, MQ013CG-E2-S7-FV and MQ013CG-E2-S7-NIO ..	25
15	Image quality parameters of: MQ013MG-E2-S7, MQ013MG-E2-S7-FV, MQ013MG-E2-S7-FL and MQ013MG-E2-S7-NIO	25
16	Image quality parameters of: MQ013RG-E2-S7, MQ013RG-E2-S7-FL, MQ013RG-E2-S7-FV and MQ013RG-E2-S7-NIO...	26
17	Image quality parameters of: MQ013CG-ON-S7	26
18	Image quality parameters of: MQ013MG-ON-S7	27
19	Image quality parameters of: MQ013RG-ON-S7	27
20	Image quality parameters of: MQ022CG-CM-S7 and MQ022CG-CM-S7-FL	28
21	Image quality parameters of: MQ022RG-CM-S7 and MQ022RG-CM-S7-FL	28
22	Image quality parameters of: MQ022MG-CM-S7 and MQ022MG-CM-S7-FL	29
23	Image quality parameters of: MQ042RG-CM-S7	29
24	Image quality parameters of: MQ042CG-CM-S7 and MQ042CG-CM-S7-FL	30
25	Image quality parameters of: MQ042MG-CM-S7, MQ042MG-CM-S7-FL and MQ042MG-CM-S7-NIO	30
26	Sensor read-out modes of: MQ013CG-E2-S7, MQ013MG-E2-S7, MQ013RG-E2-S7, MQ013CG-E2-S7-FL, MQ013CG-E2-S7-FV, MQ013MG-E2-S7-FV, MQ013RG-E2-S7-FL, MQ013RG-E2-S7-FV, MQ013MG-E2-S7-FL, MQ013MG-E2-S7-NIO, MQ013CG-E2-S7-NIO and MQ013RG-E2-S7-NIO	31
27	Sensor read-out modes of: MQ013CG-ON-S7, MQ013MG-ON-S7 and MQ013RG-ON-S7	31
28	Sensor read-out modes of: MQ022RG-CM-S7, MQ022CG-CM-S7, MQ022MG-CM-S7, MQ022CG-CM-S7-FL, MQ022RG-CM-S7-FL and MQ022MG-CM-S7-FL	32
29	Sensor read-out modes of: MQ042CG-CM-S7, MQ042RG-CM-S7, MQ042MG-CM-S7, MQ042CG-CM-S7-FL, MQ042MG-CM-S7-FL and MQ042MG-CM-S7-NIO	32
30	Camera parameters of: MQ013CG-E2-S7, MQ013MG-E2-S7 and MQ013RG-E2-S7	36
31	Camera parameters of: MQ013MG-E2-S7-NIO, MQ013CG-E2-S7-NIO and MQ013RG-E2-S7-NIO	36
32	Camera parameters of: MQ013CG-ON-S7, MQ013MG-ON-S7 and MQ013RG-ON-S7	36
33	Camera parameters of: MQ013CG-E2-S7-FL, MQ013CG-E2-S7-FV, MQ013MG-E2-S7-FV, MQ013RG-E2-S7-FL, MQ013RG-E2-S7-FV and MQ013MG-E2-S7-FL	36
34	Camera parameters of: MQ022CG-CM-S7-FL, MQ022RG-CM-S7-FL and MQ022MG-CM-S7-FL	36
35	Camera parameters of: MQ022RG-CM-S7, MQ022CG-CM-S7, MQ022MG-CM-S7, MQ042CG-CM-S7, MQ042RG-CM-S7 and MQ042MG-CM-S7	37
36	Camera parameters of: MQ042CG-CM-S7-FL and MQ042MG-CM-S7-FL	37
37	Camera parameters of: MQ042MG-CM-S7-NIO	37
38	LED output during power up of: all models in this manual (refer to the table Models and sensors overview)	46
39	LED output description of: all models in this manual (refer to the table Models and sensors overview)	46
40	USB 3.1 micro-B mating connector description	47
41	USB 3.1 micro-B connector pin assignment	48
42	Flex cable interface mating connector description	49

43	GPIO mating connector description	50
44	I/O connector pin assignment	50
45	GPIO mating connector description	51
46	I/O connector pin assignment	51
47	General info for optically isolated digital input	53
48	General info for optically isolated digital output	54
49	CBL-U3-xM pin assignment	56
50	pin assignment	57
51	CBL-S-M5-3P-PT-xM pin assignment	59
52	CBL-S-PB3-PT-0M30 pin assignment	60
53	IO connector (WAGO 218-104), pin assignment	61
54	Image data output formats	65
55	trigger mode with overlap, timing	67
56	trigger mode w/o overlap, timing	69
57	service operations overview	94

Aegis Electronic Group
www.aegiselect.com

