

Lt1245R

12 Megapixel, Global Shutter CMOS Camera with High-Speed USB 3.1 Gen 1



About Pregius® Global Shutter CMOS Camera Technology

Sony's latest Pregius® global shutter CMOS sensors combine beneficial aspects of both CCD and CMOS in a pixel design resulting in impressive performance. The Pregius sensors have an analog pixel design similar to a CCD, but with the back end resembling a CMOS sensor. This architecture takes the advantages of a CCD sensor (excellent imaging performance – including good color reproduction, low noise, and high dynamic range) along with all the digital advantages of a CMOS sensor (built-in analog-to-digital conversion, image correction, digital output and high speed) to produce a low-power, low-cost alternative to traditional CCD sensors.

High Quality Images Coupled with Fast Frame Rates

The Lt1245R camera uses the high performance global shutter CMOS IMX253 sensor from Sony for optimal image output while operating at very fast frame rates. The Lt1245R provides the fastest full resolution images possible from the Sony Pregius® sensors when coupled with Lumenera's proven and reliable USB 3.1 Gen 1 technology.

Image captures can be synchronized using either a hardware or software trigger. FPGA-enabled performance, complemented 128MB onboard memory for low-latency frame buffering, ensure dependable and reliable image delivery even in the most demanding machine vision systems.

Plug-and-Play with No Framegrabber

The compact, robust design of this camera, measuring 44 x 44 x 61 mm, allows for easy integration into tight spaces and systems. The locking USB 3.1 Gen 1 cabling interface ensures delivery of data and power, a simple plug-and-play installation with standard distances of 3 meters, and up to 100 meters with available active copper and optical cable solutions. USB3 Vision compliancy allows for simple third party software integration.

Maximize Camera Performance Within Your Own Application

The Lumenera Camera SDK provides a full suite of features and functions that allow you to maximize the camera's performance within your own vision application with minimal work. The SDK is compatible with all of our USB and GigE-based cameras. Microsoft DirectX/DirectShow, Windows API and .NET API interfaces are provided, allowing you the choice of application development environments from C/C++ to VB.NET or C#.NET.

Technical Assistance Center

All Lumenera cameras are supported by an experienced team of pre-sales and technical support imaging experts widely acclaimed in the industry. We understand your imaging needs and are here to help you get the most out of your camera.

Features

- Color or monochrome Sony IMX253 electronic global shutter CMOS sensor with 1.1" optical format
- High-Speed USB 3.1 Gen 1 interface for fastest image delivery and simplified connectivity
- P-Iris connector for support of precise iris lens control
- Compact, robust form factor measuring 44 x 44 x 61 mm
- Flexible mounting options with one tripod (1/4"-20) mount, eight 4-40 mounting points, and eight 2-56 alignment points
- Locking industrial micro USB (power / data) and Hirose (GPI/O and power) connectors for power and control of peripherals and synchronization of lighting
- 4 GPI/O options: 1 optically isolated output, 1 optically isolated input, and 2 configurable I/O ports controls for synchronization (trigger and strobe) of multiple cameras, peripherals, and lighting
- 128 MB low-latency RAM frame buffer
- Simplified cabling – video and full camera control over a single locking micro USB 3.0 cable
- Region of Interest (ROI) option to provide higher frame rates
- Selectable 8 or 12-bit pixel data
- Multiple data rates supported, each optimized for lowest noise performance
- FCC Class B, CE Certified
- USB3 Vision, DirectShow compatible
- Software compatible with Windows 10, Windows 8.1, Windows 7, Linux, 32 and 64-bit operating systems
- Complete Windows and Linux SDKs available
- Three (3) year warranty

Color Quantum Efficiency

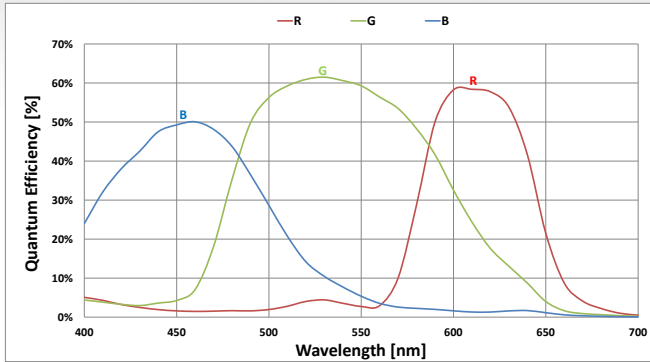

Monochrome Quantum Efficiency

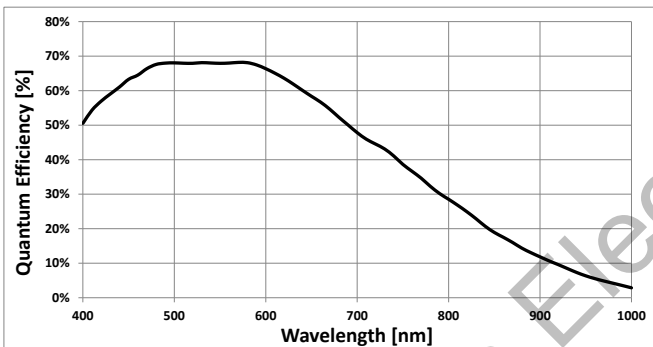

Recommended Applications

- UAV, Aerial Imaging
- Multispectral Imaging
- High Resolution Surveillance
- Machine Vision Inspection
- High Resolution Fluorescence Imaging
- Whole Slide Imaging
- Large Area Scan
- ITS (Intelligent traffic solutions)

Sensor Specifications	
Image Sensor	Sony IMX253, CMOS, color, monochrome
Optical Format	1.1"
Imager Size	Diagonal 17.6 mm
Pixel Size	3.45 x 3.45 μm
Resolution	4112 x 3008 pixels
Region of Interest Control	Yes
Camera Specifications	
Max Frame Rate	~30 fps at full resolution
Bit Depth	8 or 12-bit
Exposure Control	Manual and automatic control
Exposure Range	32μs to 71.6m (snapshot); 14μs to 15.5s (video)
Gain Control	Manual and automatic control
Gain Range	~ 1 to 256 x
White Balance	Manual and automatic control
Trigger Modes	Hardware and software triggerable
Camera Characteristics	
Sensitivity	Mono: 5.0 DN/(nJ/cm ²), Color: 4.5 DN/(nJ/cm ²) (Global and channel gains at unity)
Dynamic Range	~74 dB
Full Well Capacity	~ 10,500 e-
Quantum Efficiency	61% @ 530 nm peak color, 68% @ 570nm peak mono
Read Noise	~2.41 e-
Dark Current	1.2 e-/s (at 22 °C ambient, 35 °C internal camera)
Mechanical Specifications	
Data Interface	USB 3.1, micro locking connector
General Purpose I/O	Locking Hirose MXR-8R-8SA(71)
Lens Mount	C-Mount
Dimensions	44 x 44 x 61 mm
Mass	~140 g
Operating Temperature	0 to 50 °C
Storage Temperature	-30 to 70 °C
Operating Humidity	5 to 95 %, non-condensing
Shock	IEC60721-4-7 Class 7M2 & IEC60068-2-27
Sinusoidal & Random Vibration	IEC60721-4-7 Class 7M2 & IEC60721-4-2 Class 2M2 IEC60068-2-6 & IEC60068-2-64
Ingress Protection Rating	IP51 (Optical Path)
Onboard Memory	Camera has onboard non-volatile memory storage
Camera Software	
Operating Systems	Windows 10, Windows 8.1, Windows 7, Linux, 32 and 64-bit operating systems
Software Interfaces	USB3 Vision, DirectShow
Power and Emissions	
Power Consumption	~4W
Power Requirement	Power over USB or optional La2000PIOK / La2000PK power kit to provide 5 V DC, 1.5 A, power through GPIO
Emissions Compliances	FCC Class B, CE Certified
Hazardous Materials	RoHS, WEEE Compliant
Warranty	Three (3) year
Ordering Options	
Lt1245RM	12 MP Monochrome Camera
Lt1245RC	12 MP Color Camera
La2000PK	Power Supply via GPIO connector (power only)
La2000PIOK	Power Supply with GPIO cable (leads + power)
La050315	Transformer, 5VDC, 15W, 3A, International
La303ML	Cable, USB 3.0, 3m, A-micro B, locking
LuSDK	Software Developer's Kit (Web Download)
Customization Options	
-SCI	Scientific grade
-WOIR	Without IR glass installed - uses AR/AR clear glass within lens mount
-WIR	With IR glass installed for mono cameras
-U3V	USB 3 Vision support

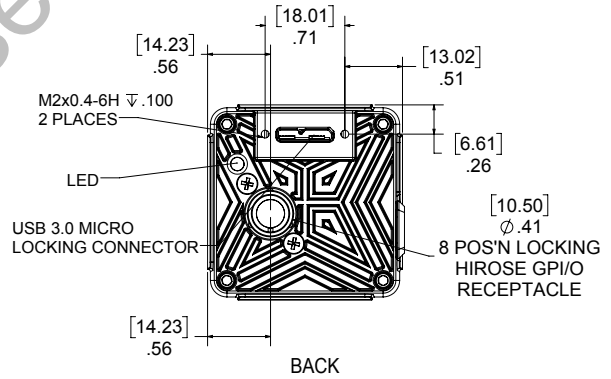
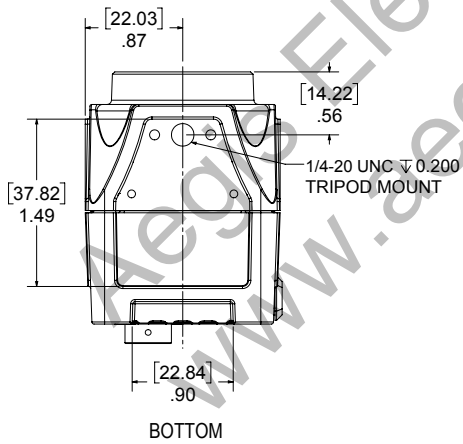
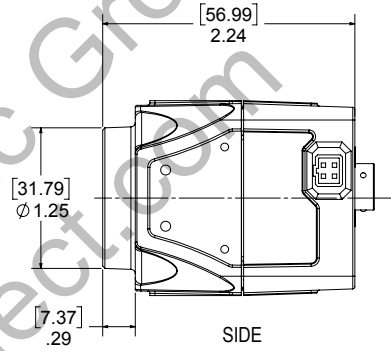
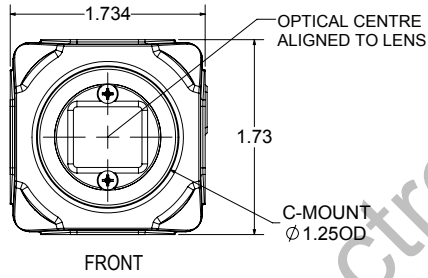
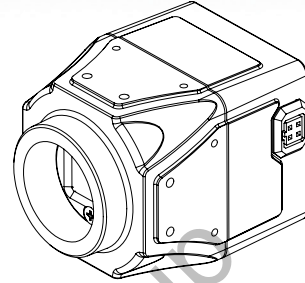
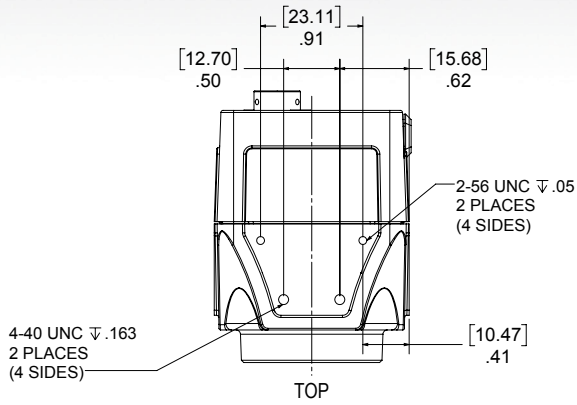

ALL DIMENSIONS DISPLAYED AS INCHES (MM)

ALL DIMENSIONS DISPLAYED AS INCHES (MM)