

Preliminary

# VTS-4K5X-H300A-256

High Speed & High Sensitivity 4k TDI Line Scan Cameras



**CoaXPRESS**<sup>®</sup>

VTS-4K5X-H300A-256, the new hybrid Time Delayed Integration (TDI) line scan camera equipped with four CoaXPRESS channels, provide faster line rates and higher sensitivity than existing line scan cameras. With hybrid TDI line scan technology combining with BSI(Backside-Illuminated) sensor, the VTS-4K5X-H300A-256 camera delivers line rates of up to 300kHz at 4k resolution with 256× higher sensitivity. Even superior sensitivity, up to 4640 pixel resolution at a maximum line rate of 300kHz and 256× greater sensitivity can be achieved using the VTS-4K5X-H300A-256 camera. Featured with high speed and high sensitivity, this camera is ideal for demanding applications such as flat panel inspection, wafer inspection, printed circuit board inspection, and high-performance document scanning.

# VTS-4K5X-H300A-256

High Speed & High Sensitivity 4k TDI Line Scan Cameras

## Mechanical Dimensions

Unit: mm

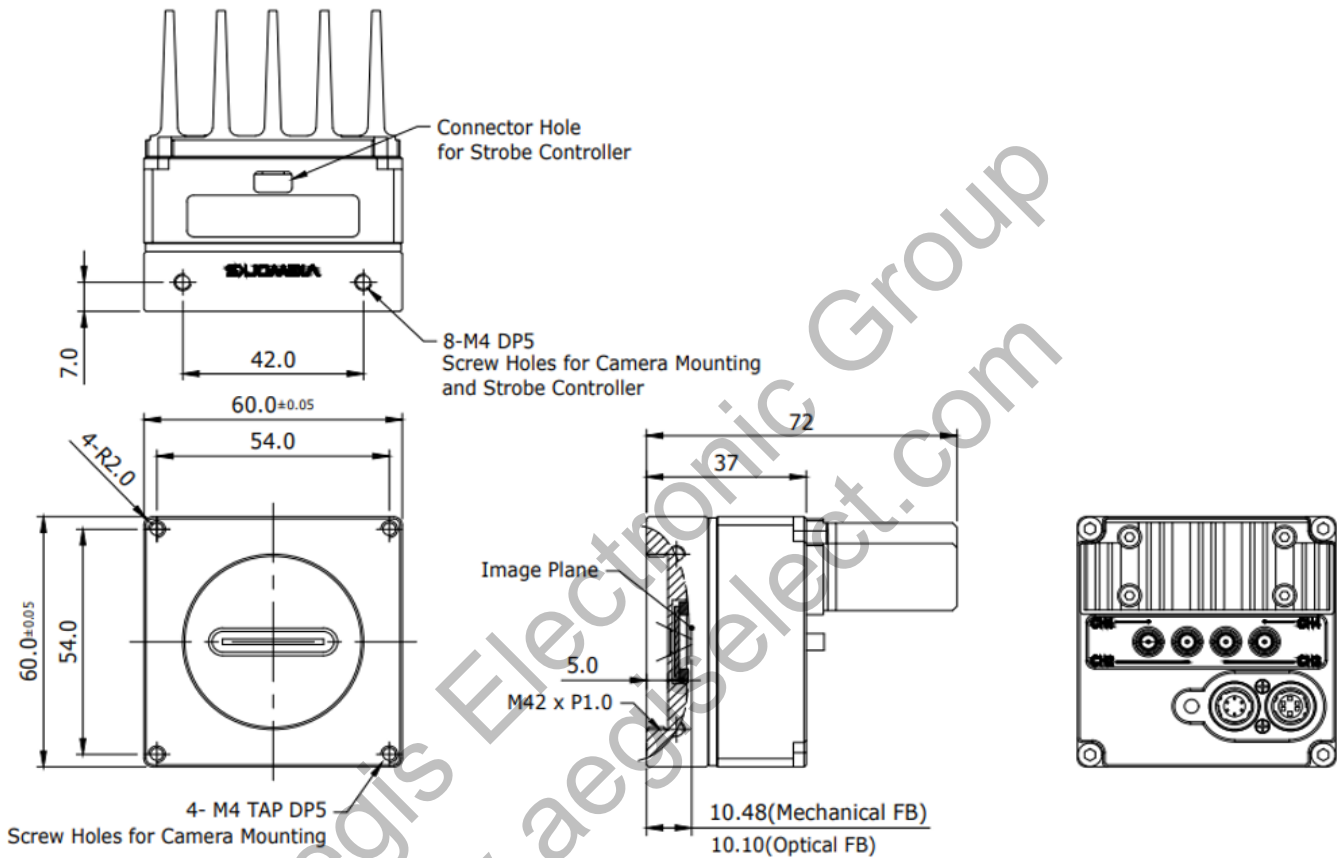

# VTS-4K5X-H300A-256

High Speed & High Sensitivity 4k TDI Line Scan Cameras

## Main Features

- BSI (Backside Illuminated) Sensor
- CoaXPress Interface up to 300kHz at 25Gbps using 4CH
- Bidirectional Operation with up to 256 TDI Stages
- Advanced DSNU and PRNU Correction
- Trigger Rescaler and Strobe Output Control
- GenICam Compatible – XML based Control

## Applications

- Flat Panel Display Inspection
- PCB Inspection
- Machine Vision Inspection
- Microscopy and Metrology

## Specifications

Model	VTS-4K5X-H300A-256	
Resolution (H × V)	4640 × 256	
Sensor	BSI (Backside Illuminated) Sensor	
Pixel Size	5.0 μm × 5.0 μm	
Interface	CoaXPress (CXP1.0), 4 CH	
Max. Line Rate	2 x 2 Binning: 257kHz 3 x 3 Binning: 225kHz 4 x 4 Binning: 200kHz	
Min. Line Rate	1kHz	
Pixel Data Format	8 / 10 / 12 bit	
TDI Stages	64 / 128 / 192 / 256	
Trigger Synchronization	Free-Run, External Trigger Signal, CoaXPress	
Throughput	1.39 Gpix/s	
Gamma Correction	User Defined Lookup Table (LUT)	
Black Level Control	-256 ~ 255 at 8 bit	
Gain Control	Analog Gain: 1×, 2×, 3×, 4× / Digital Gain: 1.0× ~ 32.0×	
Dynamic Range	63dB	
Lens Mount	M42 x 1mm	
Dimension / Weight	60 mm × 60 mm × 72 mm / 280 g	
Temperature	Ambient Operating: 0°C ~ 40°C (Housing: 10°C ~ 55°C) Storage: -40°C ~ 70°C	
Power	External	12 ~ 24 V DC
	Dissipation	Typ. 6.0 W / Max.8.4 W
	PoCXP	24 V DC, Minimum of one PoCXP cable required
Compliance	CE, FCC, KC	
API SDK	Vieworks Imaging Solution 7.X	

# VTS-4K5X-H300A-256

High Speed & High Sensitivity 4k TDI Line Scan Cameras

## Quantum Efficiency

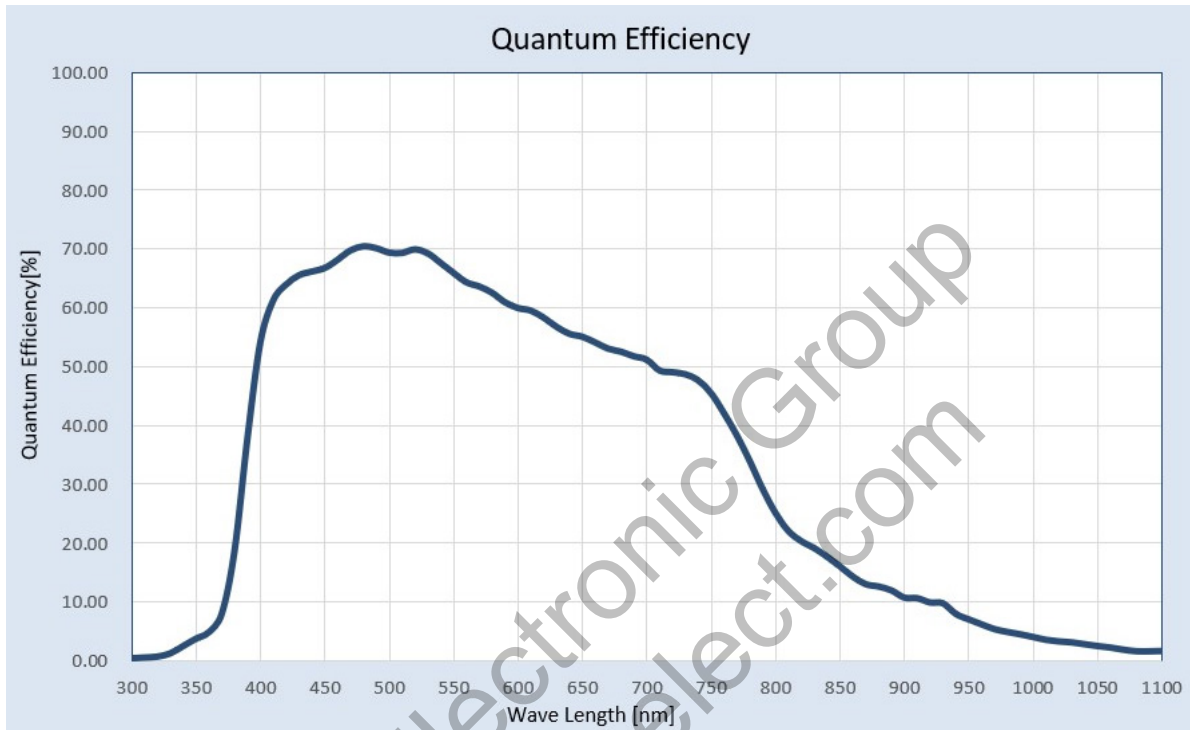

## Ordering Scheme

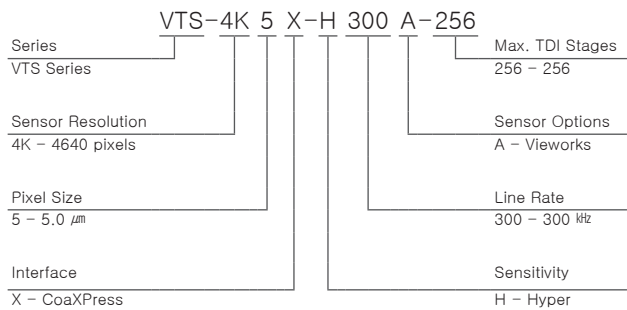

## Connector Specification

### Power



1, 2, 3: +12 V DC  
4, 5, 6: GND  
(HR10A-7R-6PB)

### Control

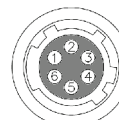

1: Trigger IN  
2: Direction IN  
3: GND  
4: GND  
5: NC  
6: Strobe Out  
(HR10A-7R-6SB)

### Data Transfer / Communications



CH1: Master Connection  
(75  $\Omega$ , DIN 1.0/2.3)

Connectors on camera body