

# VTC Series

2k Color TDI Line Scan Cameras



The VTC-2K10.5C, VTC-2K10.5X and VTC-2K10.5G, the new hybrid color Time Delayed Integration (TDI) line scan cameras, provide faster line rates and higher sensitivity than existing line scan cameras. With hybrid TDI line scan technology combining the strengths of both CCD and CMOS image sensors, the M42 mount-based VTC-2K10.5C/X/G cameras can acquire True Color images at faster line rates with up to 80 times higher sensitivity. These 2k color TDI line scan cameras are available with the Camera Link, GigE or CoaxPress interface standard to meet application-specific requirements. Featured with high speed and high sensitivity, these cameras are ideal for demanding applications such as flat panel inspection, wafer inspection, printed circuit board inspection, and high-performance document scanning.

# VTC-2K10.5C / VTC-2K10.5X / VTC-2K10.5G

2k Color TDI Line Scan Cameras

## Main Features

- Hybrid Color TDI Line Scan
- True Color Imaging
- 2160 × 80 Pixel Resolution
- Bidirectional Operation with up to 80 TDI Stages
- Supports Camera Link, GigE and CoaXPress
- Advanced DSNU and PRNU Correction
- Trigger Rescaler and Strobe Output Control

## Applications

- Flat Panel Display Inspection
- PCB Inspection
- Machine Vision Inspection
- Microscopy and Metrology

## Specifications

Model	VTC-2K10.5C-C100A-80	VTC-2K10.5X-C140A-80	VTC-2K10.5G-C19A-80	
Resolution (H × V)	2160 × 80			
Sensor	Hybrid Color TDI Line Scan			
Pixel Size	10.5 μm × 10.5 μm			
Interface	Camera Link	CoaXPress	GigE	
Max. Line Rate	100 kHz	140 kHz	19 kHz	
Min. Line Rate	1 kHz			
Pixel Data Format	8 / 10 / 12 bit			
TDI Stages	20 / 40 / 60 / 80			
Trigger Synchronization	Free-Run, External, CC1	Free-Run, External, CoaXpress	Free-Run, External	
Throughput	0.22 Gpix/s	0.30 Gpix/s (CXP 2 CH)	0.04 Gpix/s	
Gamma Correction	User Defined LUT (Lookup Table)			
Black Level Control	-255 ~ 255 at 8 bit			
Gain Control	Analog Gain: 1×, 2×, 3×, 4× / Digital Gain: 1.0× ~ 8.0×			
Lens Mount	M42 × 1 mm (C or F-mount available upon request)			
Dimension / Weight	60 mm × 60 mm × 36 mm, 223 g			
Temperature	Ambient Operating: 0°C ~ 50°C (Housing: 10°C ~ 50°C), Storage: -40°C ~ 70°C			
Power	External	10 ~ 30 V DC, Typ. 5.0 W	10 ~ 30 V DC, Typ. 5.5 W	10 ~ 30 V DC, Typ. 4.5 W
	PoCXP	Not supported	24 V DC Minimum of one PoCXP cable required	Not supported
Compliance	CE, FCC, KC		CE, FCC, KC, UKCA	
API SDK	Vieworks Imaging Solution 7.X			
Config. SW for CL	Configurator	Not supported	Not supported	

# VTC-2K10.5C / VTC-2K10.5X / VTC-2K10.5G

2k Color TDI Line Scan Cameras

## Quantum Efficiency Curves

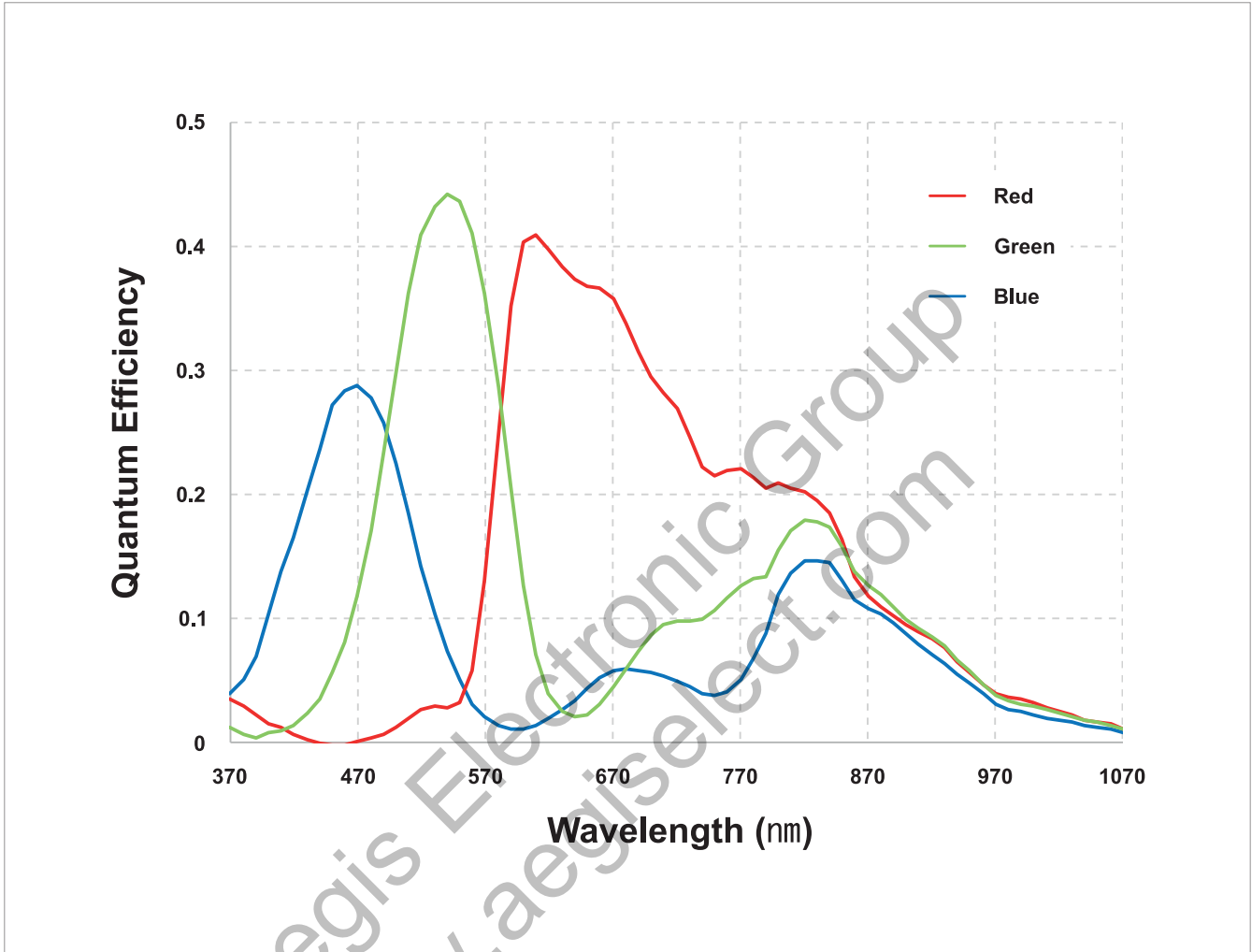

## Ordering Scheme

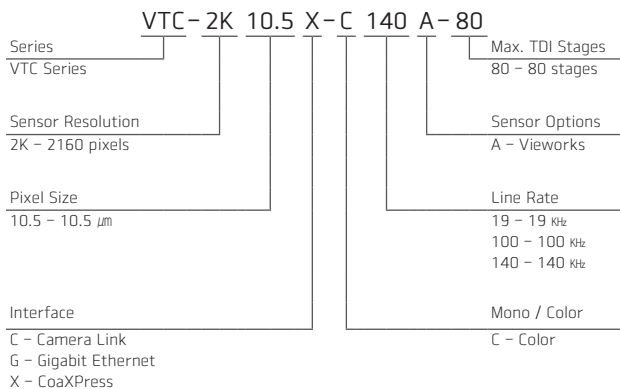

## Connector Specification

### Power Input Receptacle

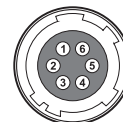

1, 2, 3: +12V DC      4, 5, 6: GND  
(HR10A-7R-6PB)

### Control I/O Receptacle for CL and CXP

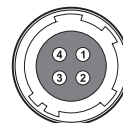

1: Trigger IN+      2: Trigger IN-  
3: Strobe Out-(GND)      4: Strobe OUT+  
(HR10A-7R-4S)

### Control I/O Receptacle for GigE

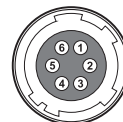

1: Trigger IN1+      2: Trigger IN1-  
3: Strobe Out      4: DC Ground  
5: Trigger IN2+      6: Trigger IN2-  
(HR10A-7R-6SB)

Connectors on camera body

# VTC-2K10.5C / VTC-2K10.5X / VTC-2K10.5G

2k Color TDI Line Scan Cameras

## Mechanical Dimensions

Unit: mm

