

## Blackmagic PYXIS 6K PL



**\$3,195**

Blackmagic PYXIS 6K PL is an advanced digital film camera with an incredibly versatile design that lets you build the perfect camera rig for your production. This new model features a 6048 x 4032 full frame HDR sensor with built in optical low pass filter, dual native ISO, dual CFexpress media slots, all in a customizable body with flexible mounting options and side plates. Blackmagic PYXIS 6K PL features a fixed PL mount that works with high quality professional cinema lenses.

### Camera Features

#### Effective Sensor Size

36mm x 24mm (Full Frame)

#### Lens Mount

PL mount with /i Technology.

#### Lens Control

Iris and focus on supported lenses.

#### Dynamic Range

13 Stops.

#### Dual Native ISO

400 and 3200

#### Shooting Resolutions

6048 x 4032 (Open Gate 3:2) up to 36 fps

4832 x 4032 (Anamorphic 6:5) up to 36 fps

6048 x 3408 (6K 16:9) up to 46 fps

6048 x 3200 (6K DCI 17:9) up to 48 fps

6048 x 2520 (6K 2.4:1) up to 60 fps

4096 x 3072 (Super 35 4:3) up to 50 fps

4096 x 2304 (4K 16:9) up to 60 fps

4096 x 2160 (4K DCI 17:9) up to 60 fps

2112 x 1184 (Super 16 16:9) up to 100 fps

1920 x 1080 (1080 HD 16:9) up to 120 fps

#### Frame Rates

Maximum sensor frame rate dependent on resolution and codec selected. Project frame rates of 23.98, 24, 25, 29.97, 30, 50, 59.94 and 60 fps supported.

Off-speed frame rates up to 60 fps in 6K 2.4:1 and 4K DCI 17:9, 100 fps in Super 16 16:9 and 120 fps in 1080HD.

#### Focus

Manual focus only.

#### Iris Control

Manual iris control only.

#### Screen Dimensions

4" 1920 x 1080.

#### Screen Brightness

1500 nits

#### Screen Type

LCD capacitive touchscreen.

#### Metadata Support

Automatically populated lens data from /i Technology PL lenses.

Automatic recording of camera settings, motion sensor data plus slate data such as project, scene number, take and special notes. A 3D LUT can also be embedded in metadata of Blackmagic RAW files.

#### Controls

Touchscreen menus on 4 inch screen. Push buttons for other controls. 3 assignable shortcut keys.

#### Timecode Clock

Highly accurate timecode clock. Less than 1 frame drift every 8 hours.

---

## Connections

### Total Video Inputs

None

### Total Video Outputs

1 x 12G-SDI up to 2160p60

1 x Viewfinder USB-C with power, data, video and locking connector.

### Analog Audio Inputs

1 x mini XLR analog audio in, switchable between mic with phantom power support and line level (up to +14dBu).

1 x 3.5mm Stereo Input.

### Analog Audio Outputs

1 x 3.5mm headphone jack.

### Reference Inputs

Tri-Sync/Black Burst and Timecode.

### Computer Interface

USB Type-C for external drive recording, PTP camera control and software updates.

### Ethernet

1 x 1Gb/s RJ-45 connector supporting 10/100/1000 BASE-T.

Aegis Electronic Group  
www.aegiselect.com

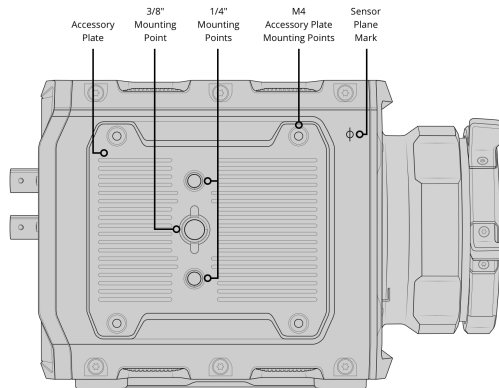
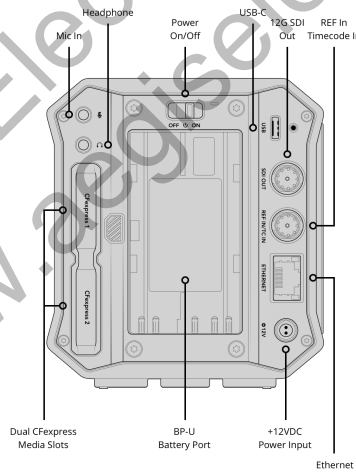
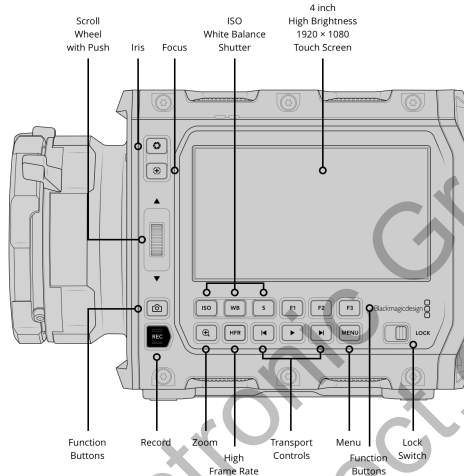
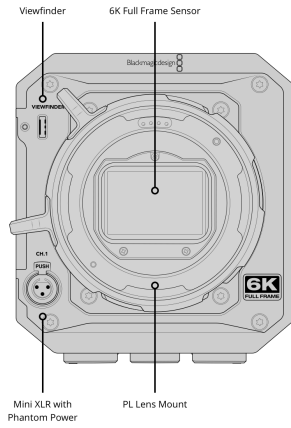

2 x 3/8" and 7 x 1/4"  
Tripod Mounting Points

---

## Standards

### HD Video Standards

1080p23.98, 1080p24, 1080p25,  
1080p29.97, 1080p30, 1080p50,  
1080p59.94, 1080p60

### Ultra HD Video Standards

2160p23.98, 2160p24, 2160p25,  
2160p29.97, 2160p30, 2160p50,  
2160p59.94, 2160p60

### SDI Compliance

SMPTE 424M, SMPTE 425M level A  
and B, SMPTE 2081-1,  
SMPTE 2081-10, SMPTE 2082-1  
and SMPTE 2082-10.

### SDI Audio Sampling

Television standard sample rate of 48  
kHz and 24-bit.

---

## Audio

### Microphone

Integrated stereo microphone.

### Built in Speaker

1 x mono speaker.

---

## Media

### Media

2 x CFexpress Type B card slot,  
1 x USB-C 3.1 Gen 1 expansion port  
for external media for Blackmagic  
RAW and H.264 Proxy Recording.  
Please refer to either the Manual or  
the Information Note at  
[www.blackmagicdesign.com/support](http://www.blackmagicdesign.com/support)  
for compatible media.

### Media Format

Can format media to ExFAT  
(Windows/Mac) or HFS+ (Mac)  
file systems.

---

## Supported Codecs

### Codecs

Blackmagic RAW Constant Bitrate 3:1,  
Blackmagic RAW Constant Bitrate 5:1,  
Blackmagic RAW Constant Bitrate 8:1,  
Blackmagic RAW Constant Bitrate  
12:1,  
Blackmagic RAW Constant Quality Q0,  
Blackmagic RAW Constant Quality Q1,  
Blackmagic RAW Constant Quality Q3,  
Blackmagic RAW Constant Quality Q5,  
H.264 Proxy in 1920 x 1080, 8-bit  
4:2:0

---

## Control

### External Control

iPad control, Bluetooth control, USB PTP camera control. External control of some camera settings, focus, iris and zoom with compatible lenses. Camera Control REST API over Ethernet for external control via HTTP when used with REST client applications such as Postman.

---

## Network Management

### NTP

Network time protocol support allows you to sync the time on your camera, whenever connected to a network with any NTP server of your choice.

### Web Media Manager

Using a browser connected over Ethernet, web media manager allows you to access, browse, download and delete files from any drive connected to the camera.

### FTP

Download files from any drive attached to your camera using FTP.

### SMB

File sharing using SMB

---

## Storage Features

### Storage Type

2 x CFexpress Type B

1 x high speed USB-C expansion port for external media.

### Recording Formats

Blackmagic RAW 3:1, 5:1, 8:1, 12:1, Q0, Q1, Q3 and Q5 at 6048 x 4032, 4832 x 4032, 6048 x 3408, 6048 x 3200, 6048 x 2520, 4096 x 3072, 4096 x 2304, 4096 x 2160, 2112 x 1184 and 1920 x 1080 with film, extended video, video dynamic range or custom 3D LUT embedded in metadata.

Supports recording optional portrait mode metadata for all resolutions in Blackmagic RAW and H.264 Proxies.

### Storage Rates

Storage rates based on 30 frames per second.

---

6048 x 4032 (6K Open Gate 3:2)	Blackmagic RAW 3:1 - 233 MB/s	4096 x 3072 (Super 35 4:3)
Blackmagic RAW 3:1 - 370 MB/s	Blackmagic RAW 5:1 - 140 MB/s	Blackmagic RAW 3:1 - 192 MB/s
Blackmagic RAW 5:1 - 223 MB/s	Blackmagic RAW 8:1 - 88 MB/s	Blackmagic RAW 5:1 - 116 MB/s
Blackmagic RAW 8:1 - 140 MB/s	Blackmagic RAW 12:1 - 59 MB/s	Blackmagic RAW 8:1 - 73 MB/s
Blackmagic RAW 12:1 - 94 MB/s	Blackmagic RAW Q0 - 175 to 348 MB/s	Blackmagic RAW 12:1 - 49 MB/s
Blackmagic RAW Q0 - 278 to 555 MB/s	Blackmagic RAW Q1 - 117 to 279 MB/s	Blackmagic RAW Q0 - 145 to 288 MB/s
Blackmagic RAW Q1 - 186 to 444 MB/s	Blackmagic RAW Q3 - 78 to 199 MB/s	Blackmagic RAW Q1 - 97 to 231 MB/s
Blackmagic RAW Q3 - 124 to 318 MB/s	Blackmagic RAW Q5 - 47 to 117 MB/s	Blackmagic RAW Q3 - 65 to 165 MB/s
Blackmagic RAW Q5 - 75 to 186 MB/s		Blackmagic RAW Q5 - 39 to 97 MB/s
4832 x 4032 (Anamorphic 6:5)		4096 x 2160 (4K 16:9)
Blackmagic RAW 3:1 - 297 MB/s		Blackmagic RAW 3:1 - 144 MB/s
Blackmagic RAW 5:1 - 179 MB/s		Blackmagic RAW 5:1 - 87 MB/s
Blackmagic RAW 8:1 - 112 MB/s		Blackmagic RAW 8:1 - 55 MB/s
Blackmagic RAW 12:1 - 75 MB/s		Blackmagic RAW 12:1 - 37 MB/s
Blackmagic RAW Q0 - 223 to 445 MB/s		Blackmagic RAW Q0 - 108 to 216 MB/s
Blackmagic RAW Q1 - 149 to 356 MB/s		Blackmagic RAW Q1 - 73 to 173 MB/s
Blackmagic RAW Q3 - 100 to 255 MB/s		Blackmagic RAW Q3 - 49 to 124 MB/s
Blackmagic RAW Q5 - 60 to 149 MB/s		Blackmagic RAW Q5 - 30 to 73 MB/s
6048 x 3408 (6K 16:9)		4096 x 2160 (4K DCI 17:9)
Blackmagic RAW 3:1 - 313 MB/s		Blackmagic RAW 3:1 - 136 MB/s
Blackmagic RAW 5:1 - 188 MB/s		Blackmagic RAW 5:1 - 82 MB/s
Blackmagic RAW 8:1 - 118 MB/s		Blackmagic RAW 8:1 - 52 MB/s
Blackmagic RAW 12:1 - 79 MB/s		Blackmagic RAW 12:1 - 35 MB/s
Blackmagic RAW Q0 - 235 to 469 MB/s		Blackmagic RAW Q0 - 102 to 203 MB/s
Blackmagic RAW Q1 - 157 to 375 MB/s		Blackmagic RAW Q1 - 69 to 163 MB/s
Blackmagic RAW Q3 - 104 to 268 MB/s		Blackmagic RAW Q3 - 46 to 117 MB/s
Blackmagic RAW Q5 - 63 to 157 MB/s		Blackmagic RAW Q5 - 28 to 69 MB/s
6048 x 3200 (6K DCI 17:9)		2112 x 1184 (Super 16 16:9)
Blackmagic RAW 3:1 - 295 MB/s		Blackmagic RAW 3:1 - 40 MB/s
Blackmagic RAW 5:1 - 177 MB/s		Blackmagic RAW 5:1 - 24 MB/s
Blackmagic RAW 8:1 - 111 MB/s		Blackmagic RAW 8:1 - 16 MB/s
Blackmagic RAW 12:1 - 75 MB/s		Blackmagic RAW 12:1 - 11 MB/s
Blackmagic RAW Q0 - 221 to 441 MB/s		Blackmagic RAW Q0 - 30 to 59 MB/s
Blackmagic RAW Q1 - 148 to 353 MB/s		Blackmagic RAW Q1 - 21 to 48 MB/s
Blackmagic RAW Q3 - 99 to 253 MB/s		Blackmagic RAW Q3 - 14 to 34 MB/s
Blackmagic RAW Q5 - 60 to 148 MB/s		Blackmagic RAW Q5 - 9 to 21 MB/s
6048 x 2520 (6K 2.4:1)		1920 x 1080
		Blackmagic RAW 3:1 - 33 MB/s
		Blackmagic RAW 5:1 - 20 MB/s
		Blackmagic RAW 8:1 - 13 MB/s
		Blackmagic RAW 12:1 - 9 MB/s
		Blackmagic RAW Q0 - 25 to 49 MB/s
		Blackmagic RAW Q1 - 17 to 40 MB/s
		Blackmagic RAW Q3 - 12 to 29 MB/s
		Blackmagic RAW Q5 - 8 to 17 MB/s

Constant Quality storage rates quoted are indicative only.

Actual storage rates are entirely dependent on image subject matter.

---

## Software

### Software Included

Blackmagic OS  
DaVinci Resolve Studio for Mac and Windows including activation key  
Blackmagic Camera Setup  
Blackmagic RAW Player  
Blackmagic RAW QuickLook Plugin  
Blackmagic RAW SDK  
Blackmagic RAW Speed Test

---

## Operating Systems



Mac 13.0 Ventura,  
Mac 14.0 Sonoma or later.



Windows 10 and 11.

---

## Power Requirements

### Power Supply

1 x External 12V DC 60 W  
power supply.

### External Power Input

1 x 2-pin locking connector.

### Power

11-19.5V

### Battery Type

BP-U series.

---

## Accessories

### Optional Accessories

Blackmagic URSA Cine Handle  
Blackmagic URSA Cine EVF  
Blackmagic PYXIS Rosette Plate

---

---

## Physical Specifications



---

## Environmental Specifications

### Operating Temperature

0° to 40°C (32° to 104°F)

### Storage Temperature

-20° to 45°C (-4° to 113°F)

### Relative Humidity

0% to 90% non-condensing

---

## What's Included

Blackmagic PYXIS 6K PL  
Lens turret dust cap  
PYXIS Standard Plate  
PYXIS SSD Plate  
60W power supply with locking connector and international adapters  
Welcome booklet  
DaVinci Resolve Studio activation key

---

## Warranty

### Product Warranty

1 Year Limited Manufacturer's Warranty.

Blackmagic Design Authorized Reseller

This information is brought to you by:



Aegis Electronic Group  
[www.aegiselect.com](http://www.aegiselect.com)