

Blackmagic Pocket Cinema Camera 6K G2



\$1,995

The Blackmagic Pocket Cinema Camera 6K G2 is an advanced technology, handheld 6K digital film camera with 6144 x 3456 Super 35 high resolution HDR sensor, dual native ISO, EF lens mount and direct recording to USB-C disks! This powerful model adds an adjustable touchscreen, and a larger battery for longer run time. You can even add an optional OLED viewfinder!

Camera Features

Effective Sensor Size

23.10mm x 12.99mm (Super 35)

Lens Mount

Active EF mount.

Lens Control

Iris, focus and zoom on supported lenses.

Dynamic Range

13 Stops.

Dual Native ISO

400 and 3200

Shooting Resolutions

6144 x 3456 (6K) up to 50 fps
 6144 x 2560 (6K 2.4:1) up to 60 fps
 5744 x 3024 (5.7K 17:9) up to 60 fps
 4096 x 2160 (4K DCI) up to 60 fps
 3840 x 2160 (Ultra HD) up to 60 fps
 3728 x 3104 (3.7K 6:5 anamorphic) up to 60 fps
 2880 x 1512 (2.8K 17:9) up to 120 fps
 1920 x 1080 (HD) up to 120 fps

Frame Rates

Maximum sensor frame rate dependent on resolution and codec selected. Project frame rates of 23.98, 24, 25, 29.97, 30, 50, 59.94 and 60 fps supported.

Off-speed frame rates up to 60 fps in 6K 2.4:1, 120 fps in 2.8K 17:9 and 1080HD.

Built in ND Filters

None

Focus

Auto focus available using compatible lenses.

Iris Control

Iris wheel and touchscreen slider for manual iris adjustment on electronically controllable lenses, iris button for instant auto iris settings on compatible lenses.

Screen Dimensions

5" 1920 x 1080.

Screen Type

LCD capacitive touchscreen.

Metadata Support

Automatically populated lens data from electronic EF lenses. Automatic recording of camera settings, motion sensor data plus slate data such as project, scene number, take and special notes. A 3D LUT can also be embedded in metadata of Blackmagic RAW files.

Controls

Touchscreen menus on 5 inch screen. 1 x Power Switch, 1 x Record Button, 1 x Stills Button, 1 x Scroll Wheel with push integrated into handgrip, 1 x ISO Button, 1 x White Balance, 1 x Shutter Button, 3 x software configurable Fn buttons, 1 x IRIS Button, 1 x Focus Button, 1 x High Frame Rate (HFR) Button, 1 x Zoom Button, 1 x Menu Button and 1 x Playback Button.

Timecode Clock

Highly accurate timecode clock. Less than 1 frame drift every 8 hours.

Connections

Total Video Inputs

None

Total Video Outputs

1 x HDMI up to 1080p60

Analog Audio Inputs

2 x mini XLR analog switchable between mic with phantom power support and line level (up to +14dBu).
1 x 3.5mm Stereo Input.
All audio inputs can also be used for Timecode input.

Analog Audio Outputs

1 x 3.5mm headphone jack.

Computer Interface

USB Type-C for external drive recording, PTP camera control and software updates.

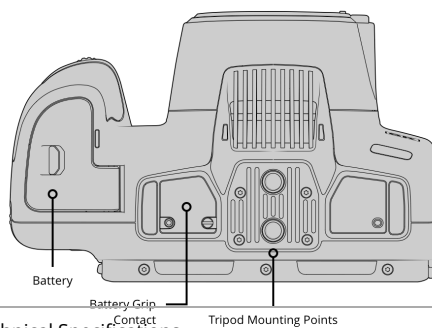
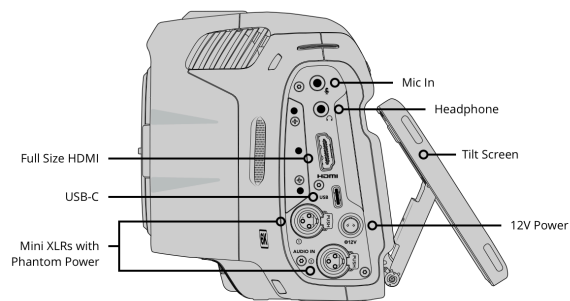
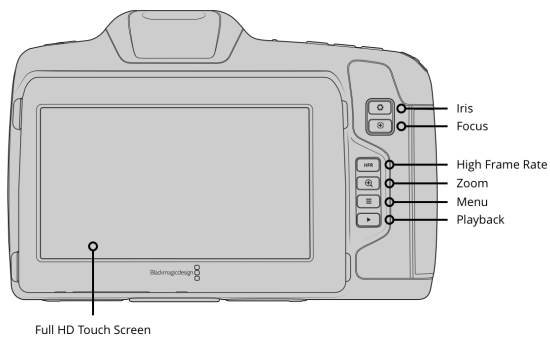
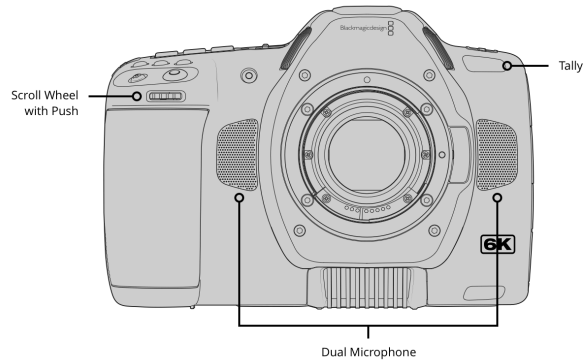
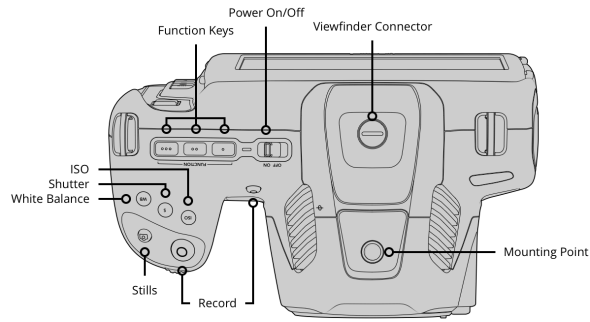

Audio

Microphone

Integrated stereo microphone.

Built in Speaker

1 x mono speaker.

Standards

SD Video Standards

None

HD Video Standards

1080p23.98, 1080p24, 1080p25,
1080p29.97, 1080p30, 1080p50,
1080p59.94, 1080p60

Ultra HD Video Standards

2160p23.98, 2160p24, 2160p25,
2160p29.97, 2160p30, 2160p50,
2160p59.94, 2160p60

4K DCI Standards

4Kp23.98 DCI, 4Kp24 DCI, 4Kp25 DCI,
4Kp29.97 DCI, 4Kp30 DCI, 4Kp50 DCI,
4Kp59.94 DCI, 4Kp60 DCI

Media

Media

1 x CFast card slot, 1 x SD UHS-II card slot, 1 x USB-C 3.1 Gen 1 expansion port for external media for Blackmagic RAW and ProRes Recording. Please refer to either the Manual or the Information Note at www.blackmagicdesign.com/support for compatible media.

Media Format

Can format media to ExFAT (Windows/Mac) or HFS+ (Mac) file systems.

Supported Codecs

Codecs

Blackmagic RAW Constant Bitrate 3:1,
Blackmagic RAW Constant Bitrate 5:1,
Blackmagic RAW Constant Bitrate 8:1,
Blackmagic RAW Constant Bitrate 12:1,
Blackmagic RAW Constant Quality Q0,
Blackmagic RAW Constant Quality Q1,
Blackmagic RAW Constant Quality Q3,
Blackmagic RAW Constant Quality Q5,
ProRes 422 HQ QuickTime,
ProRes 422 QuickTime,
ProRes 422 LT QuickTime,
ProRes 422 Proxy QuickTime.

Control

External Control

Blackmagic Zoom Demand and Blackmagic Focus Demand for controlling your camera and lens from tripod handles.

iPad control, Bluetooth control, USB PTP camera control. External control of some camera settings, focus, iris and zoom with compatible lenses, color corrector, tally and internal record start and stop when used with a compatible ATEM and ATEM Software Control.

Color Corrector

Color Corrector

DaVinci YRGB.

Storage Features

Storage Type

1 x CFast 2.0.

1 x SD UHS-II card.

1 x high speed USB-C expansion port for external media.

Recording Formats

Blackmagic RAW 3:1, 5:1, 8:1, 12:1, Q0, Q1, Q3 and Q5 at 6144 x 3456, 6144 x 2560, 5744 x 3024, 4096 x 2160, 3728 x 3104 and 2880 x 1512 with film, extended video, video dynamic range or custom 3D LUT embedded in metadata.

ProRes at 4096 x 2160, 3840 x 2160 and 1920 x 1080 with film, extended video or video dynamic range or custom 3D LUT.

Supports recording optional portrait mode metadata for all resolutions in Blackmagic RAW and ProRes.

Storage Rates

Storage rates based on 30 frames per second.

6144 x 3456 (6K)	3840 x 2160 (Ultra HD)
Blackmagic RAW 3:1 - 323 MB/s	Apple ProRes 422 HQ - 110 MB/s
Blackmagic RAW 5:1 - 194 MB/s	Apple ProRes 422 - 73.6 MB/s
Blackmagic RAW 8:1 - 121 MB/s	Apple ProRes 422 LT - 51 MB/s
Blackmagic RAW 12:1 - 81 MB/s	Apple ProRes Proxy - 22.4 MB/s
Blackmagic RAW Q0 - 242 to 483 MB/s	3728 x 3104 (3.7K 6:5 anamorphic)
Blackmagic RAW Q1 - 162 to 387 MB/s	Blackmagic RAW 3:1 - 177 MB/s
Blackmagic RAW Q3 - 108 to 277 MB/s	Blackmagic RAW 5:1 - 106 MB/s
Blackmagic RAW Q5 - 65 to 162 MB/s	Blackmagic RAW 8:1 - 67 MB/s
6144 x 2560 (6K 2.4:1)	Blackmagic RAW 12:1 - 45 MB/s
Blackmagic RAW 3:1 - 240 MB/s	Blackmagic RAW Q0 - 133 to 265 MB/s
Blackmagic RAW 5:1 - 144 MB/s	Blackmagic RAW Q1 - 89 to 212 MB/s
Blackmagic RAW 8:1 - 90 MB/s	Blackmagic RAW Q3 - 60 to 152 MB/s
Blackmagic RAW 12:1 - 60 MB/s	Blackmagic RAW Q5 - 36 to 89 MB/s
Blackmagic RAW Q0 - 180 to 359 MB/s	2880 x 1512 (2.8K 17:9)
Blackmagic RAW Q1 - 120 to 287 MB/s	Blackmagic RAW 3:1 - 67 MB/s
Blackmagic RAW Q3 - 80 to 205 MB/s	Blackmagic RAW 5:1 - 41 MB/s
Blackmagic RAW Q5 - 49 to 120 MB/s	Blackmagic RAW 8:1 - 26 MB/s
5744 x 3024 (5.7K 17:9)	Blackmagic RAW 12:1 - 17 MB/s
Blackmagic RAW 3:1 - 264 MB/s	Blackmagic RAW Q0 - 51 to 101 MB/s
Blackmagic RAW 5:1 - 159 MB/s	Blackmagic RAW Q1 - 34 to 81 MB/s
Blackmagic RAW 8:1 - 100 MB/s	Blackmagic RAW Q3 - 23 to 58 MB/s
Blackmagic RAW 12:1 - 67 MB/s	Blackmagic RAW Q5 - 14 to 34 MB/s
Blackmagic RAW Q0 - 198 to 396 MB/s	1920 x 1080
Blackmagic RAW Q1 - 133 to 317 MB/s	Apple ProRes 422 HQ - 27.5 MB/s
Blackmagic RAW Q3 - 89 to 227 MB/s	Apple ProRes 422 - 18.4 MB/s
Blackmagic RAW Q5 - 54 to 133 MB/s	Apple ProRes 422 LT - 12.75 MB/s
4096 x 2160 (4K DCI)	Apple ProRes Proxy - 5.6 MB/s
Blackmagic RAW 3:1 - 136 MB/s	
Blackmagic RAW 5:1 - 82 MB/s	
Blackmagic RAW 8:1 - 51 MB/s	
Blackmagic RAW 12:1 - 35 MB/s	
Blackmagic RAW Q0 - 102 to 203 MB/s	
Blackmagic RAW Q1 - 68 to 163 MB/s	
Blackmagic RAW Q3 - 46 to 116 MB/s	
Blackmagic RAW Q5 - 28 to 68 MB/s	
Apple ProRes 422 HQ - 117.88 MB/s	
Apple ProRes 422 - 78.63 MB/s	
Apple ProRes 422 LT - 54.63 MB/s	
Apple ProRes Proxy - 24.25 MB/s	

Constant Quality storage rates quoted are indicative only.

Actual storage rates are entirely dependent on image subject matter.

Software

Software Included

Blackmagic OS
DaVinci Resolve Studio for Mac and Windows including activation key
Blackmagic Camera Setup
Blackmagic RAW Player
Blackmagic RAW QuickLook Plugin
Blackmagic RAW SDK
Blackmagic RAW Speed Test

Operating Systems



Mac 13.0 Ventura,
Mac 14.0 Sonoma or later.



Windows 10 and 11.

Power Requirements

Power Supply

1 x External 12V power supply.

Battery Type

NP-F570

Power

12V-20V.

External Power Input

1 x 2-pin locking connector.

Battery Life

Approximately 60 minutes
(recording 6K RAW at 24 fps to CFast
2.0 with screen brightness at 50%)

Accessories

Optional Accessories

Blackmagic Pocket Cinema Camera Pro EVF
Blackmagic Pocket Camera Battery Pro Grip

Physical Specifications



Environmental Specifications

Operating Temperature

0° to 40°C (32° to 104°F)

Storage Temperature

-20° to 45°C (-4° to 113°F)

Relative Humidity

0% to 90% non-condensing

What's Included

Blackmagic Pocket Cinema Camera 6K G2
Lens turret dust cap
Camera strap
30W power supply with locking connector and international adapters
NP-F570 battery
NP-F series battery USB charger
Welcome booklet
DaVinci Resolve Studio activation key

Warranty

Product Warranty

1 Year Limited Manufacturer's Warranty.

All items on this website are copyright Blackmagic Design Pty. Ltd. 2025, all rights reserved. All trademarks are property of their respective owners. MSRP includes duties, but excludes sales tax and shipping costs. This website uses remarketing services to advertise on third party websites to previous visitors to our site. You can opt out at any time by changing cookie settings. [Privacy Policy](#)

Blackmagic Design Authorized Reseller