

Blackmagic URSA Cine Immersive



\$29,995

Blackmagic URSA Cine Immersive is the world's first camera system for capturing Apple Immersive Video for Apple Vision Pro. The dual 8K sensors deliver 8160 x 7200 resolution per eye with pixel level synchronization and an incredible 16 stops of dynamic range. The custom lens system is designed exclusively for URSA Cine Immersive's large format imaging sensor. Blackmagic URSA Cine Immersive comes with a massive 8TB of removable high performance media storage built in and also includes high speed 10G Ethernet and WiFi for fast media upload and syncing to Blackmagic Cloud!

Camera Features

Sensors

2 x 8K sensors.
Left eye and right eye.

Effective Sensor Size

23.66 mm x 20.88 mm each.

Pixel Pitch

2.9 microns.

Lens

Fixed focal length, 180°+ field of view,
stereo lens pair.

Dynamic Range

16 Stops.

Shooting Formats

8160 x 7200 x 2 (stereo immersive)

Frame Rates

Project frame rates of 23.98, 24, 25,
29.97, 30, 50, 59.94, 60 and
90 fps supported.

High Speed Frame Rates

8K stereo immersive up to 90 fps.

Built in ND Filters

Button activated ND filters with clear,
2-stop, 4-stop, 6-stop and 8-stop
IR ND filters.

Iris Control

Fixed iris.

Screens

2 x Monitoring Screens.
1 x Camera Status Screen.

Monitoring Screen Dimensions

5 inch.

Monitoring Screen Resolution

1920px x 1080px.

Monitoring Screen Brightness

1500 nits.

Monitoring Screen Type

LCD capacitive touchscreen.

Monitoring Options

Left Eye, Right Eye, Punch In.

Metadata Support

Discrete left and right eye optical
calibration metadata. Automatic
recording of camera settings and
slate data such as project, scene
number, take and special notes.

Controls

Touchscreen menus on 5 inch screen.
Push buttons for other controls.
7 assignable shortcut keys plus
3 assignable shortcut keys on
PYXIS Monitor.

Timecode Clock

Highly accurate timecode clock. Less
than 1 frame drift every 8 hours.

Connections

Total Video Outputs

2

SDI Rates

1.5G, 3G, 6G, 12G.

Analog Audio Inputs

2 x XLR analog switchable between mic, line and AES audio. Phantom power support.

Analog Audio Outputs

1 x 3.5mm headphone jack.

Reference Inputs

Tri-Sync/Black Burst and Timecode.

USB-C Monitor Outputs

2 x USB-C side monitor ports support URSA Cine EVF, PYXIS Monitor or DisplayPort monitors.

Computer Interface

2 x USB-C side expansion ports for camera accessories.

Software updates using side USB-C closer to rear.

Ethernet

1 x 10Gb/s RJ-45 connector supporting 10/100/1000/10G BASE-T for SMB file sharing, Web Media Management, Blackmagic Cloud uploads, camera control and streaming.

Aegis Electronic Group
www.aegiselect.com

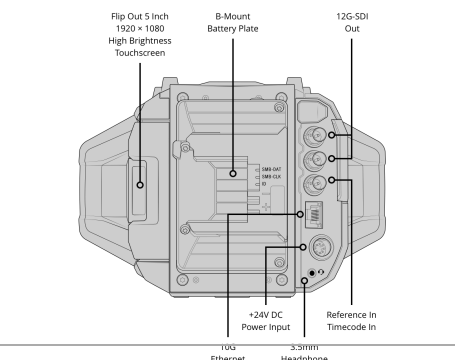
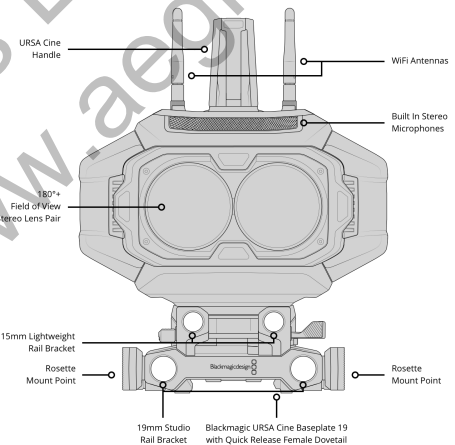
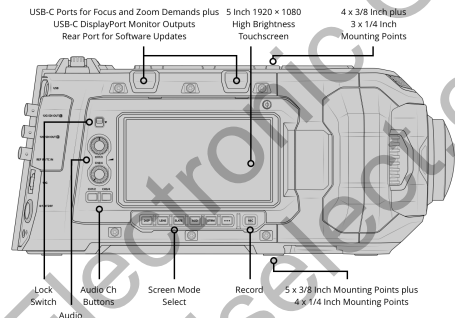
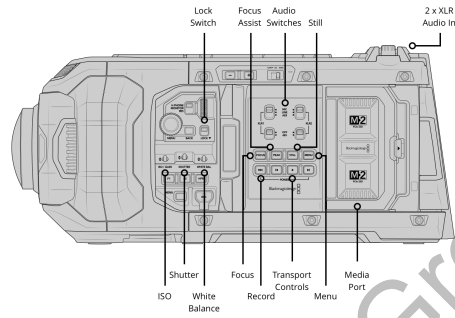
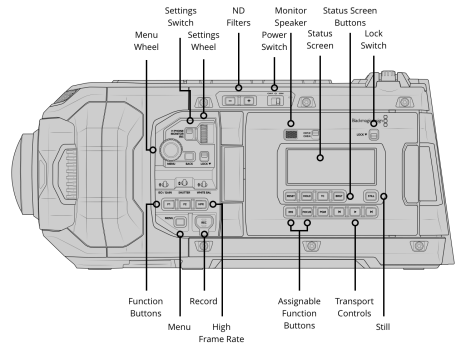

Audio

Microphone

Integrated stereo microphone.

Built in Speaker

1 x mono speaker.

Standards

SD Video Standards

None

HD Video Standards

1080p23.98, 1080p24, 1080p25,
1080p29.97, 1080p30, 1080p50,
1080p59.94, 1080p60, 1080i50,
1080i59.94, 1080i60

Ultra HD Video Standards

2160p23.98, 2160p24, 2160p25,
2160p29.97, 2160p30, 2160p50,
2160p59.94, 2160p60

SDI Compliance

SMPTE 292M, SMPTE 424 Level B,
SMPTE 2081-1, SMPTE 2082-1

SDI Audio Sampling

48 kHz and 24 bit.

Media

Media

1 x Blackmagic Media Module.

Media Format

Blackmagic

Supported Codecs

Codecs

Blackmagic RAW Constant Bitrate 5:1
Blackmagic RAW Constant Bitrate 8:1
Blackmagic RAW Constant Bitrate
12:1
Blackmagic RAW Constant Bitrate
18:1
Blackmagic RAW Constant Quality Q0
Blackmagic RAW Constant Quality Q1
Blackmagic RAW Constant Quality Q3
Blackmagic RAW Constant Quality Q5

Control

External Control

Blackmagic PYXIS Monitor can trigger record plus camera functions assigned to the F1, F2, F3. External Camera Control supported using REST API over Ethernet or WiFi. Blackmagic iPad control and Bluetooth control supported. Blackmagic Zoom Demand for controlling camera.

Network Management

NTP

Network time protocol support allows you to sync the time on your camera, whenever connected to a network with any NTP server of your choice.

FTP

Download files from any drive attached to your camera using FTP.

Web Media Manager

Using a browser connected over Ethernet, web media manager allows you to access, browse, download and delete files from any drive connected to the camera.

SMB

File sharing using SMB.

Storage Features

Storage Type

1 x Blackmagic Media Module 8TB.

Storage Rates

Storage rates based on 90 frames per second.

8K Stereo Immersive

8160 x 7200 x 2

Blackmagic RAW 5:1 - 3,202 MB/s

Blackmagic RAW 8:1 - 2,001 MB/s

Blackmagic RAW 12:1 - 1,334 MB/s

Blackmagic RAW 18:1 - 890 MB/s

Blackmagic RAW Q0 - 1,601 to 5,337 MB/s

Blackmagic RAW Q1 - 1,334 to 4,574 MB/s

Blackmagic RAW Q3 - 801 to 4,003 MB/s

Blackmagic RAW Q5 - 534 to 2,287 MB/s

Constant Quality Rates are: Q0 10:1 - 3:1, Q1 12:1 - 3.5:1, Q3 20:1 - 4:1, Q5 30:1 - 7:1

Actual storage rates are dependent on image subject matter.

Recording Formats

Blackmagic RAW 5:1, 8:1, 12:1, 18:1, Q0, Q1, Q3 and Q5 at 8160 x 7200 resolution for each eye.

Software

Software Included

URSA Cine Blackmagic OS

DaVinci Resolve Studio for Mac and Windows including activation key

Blackmagic Camera Setup

Blackmagic RAW Player

Blackmagic RAW QuickLook Plugin

Blackmagic RAW SDK

Operating Systems



Mac 13.0 Ventura,
Mac 14.0 Sonoma or later.



Windows 10 and 11.

Power Requirements

Power Supply

+24V DC external power supply 100 -
240 AC 50/60Hz compatible with IEC
C14 socket.
Molex connector for rear
battery plate.

External Power Input

1 x 8 pin Lemo compatible socket for
external power or battery use.
B-Mount battery plate.

Power Output

B-Mount battery plate including 2-pin
connector with +12V regulated
output from camera.

Accessories

Optional Accessories

Blackmagic PYXIS Monitor
Blackmagic PYXIS Monitor Kit
Blackmagic URSA Cine EVF
Blackmagic URSA Cine Battery Plate B Mnt
Blackmagic URSA Cine Battery Plate Gold
Blackmagic URSA Cine Battery Plate VLock
Blackmagic URSA Cine Baseplate 15
Blackmagic URSA Cine Baseplate 19
Blackmagic URSA Cine Handle
Blackmagic URSA Cine 5" LCD Sunshade
Blackmagic Media Dock
Blackmagic Media Module 8TB
ATEM Streaming Bridge

Physical Specifications



Environmental Specifications

Operating Temperature
0° to 40°C (32° to 104°F)

Storage Temperature
-20° to 45°C (-4° to 113°F)

Relative Humidity
0% to 90% non-condensing

What's Included

Blackmagic URSA Cine Immersive camera
Blackmagic Media Module 8TB
Blackmagic URSA Cine Handle and bolts
Blackmagic URSA Cine Baseplate 19
Blackmagic URSA Cine Battery Plate B Mount
Blackmagic URSA Cine Rubber Caps for connectors
Blackmagic URSA Cine WiFi antennas
Blackmagic URSA Cine 24V 250W power supply
Blackmagic Immersive Stereo Lens Cover
Plastic folding screen hood for 5" LCD
DaVinci Resolve Studio with activation key
Welcome wallet with QR code for software download
Pelican 1510 Case with custom foam

Warranty

1 Year Limited Manufacturer's
Warranty.

All items on this website are copyright Blackmagic Design Pty. Ltd. 2025, all rights reserved. All trademarks are property of their respective owners. MSRP includes duties, but excludes sales tax and shipping costs. This website uses remarketing services to advertise on third party websites to previous visitors to our site. You can opt out at any time by changing cookie settings. [Privacy Policy](#)

Blackmagic Design Authorized Reseller
