

Digital video camera

Equipped with the Global Shutter Polarization CMOS Sensor

GiGE Vision® XCG-CP Series

Polarization Camera

SDK for NVIDIA Jetson



XCG-CP510/CL (B/W)

- 2/3-type Polarization Image CMOS Sensor with Global Shutter Function (Pregius)
- 5.1MP 23 fps

XPL-SDKLJ

- SDK for Polarization Camera (for NVIDIA Jetson)

*XCG-CP510/CL includes license of XPL-SDKLJ

The following are made possible through the use of edge computing to analyze and process data: (1) More instantaneous processing (2) System downsizing (3) Reduction of data transmission cost.

Canceling car windshield reflection by processing polarization, allows for the inside of cars to be captured clearly, something that proved to be a difficult up until this point in the ITS market. This clarity makes it easy to identify illegal smartphone use while driving or to verify whether drivers or passengers are wearing a seatbelt.

Edge computing is gaining attention as the use of IoT technology spreads.

The XCG-CP510/CL polarization camera and SDK for polarization cameras works with NVIDIA Jetson systems, which are widely used in AI systems incorporating edge computing.

Polarsens

Pregius

Exmor



PoE support

Features

Capture a polarized image with one shot

Each individual pixel has one of four different linear polarization filters which enables four different polarization images to be captured simultaneously. Each calculation unit composed of four-pixel block supports calculation of "Polarization directions" and "Degree of Polarization (DoP)" based on luminance value on each pixel.

Feature-rich

The polarization camera SDK enables the following polarization image processing.

- Degree of Polarization (DoP)
- Surface Normal
- Reflection Removal
- Reflection Enhancement.

Work efficiency

- The polarization camera SDK enables easy polarization application development.
- Sony provides a viewer application, library, and sample source code.

Polarization Camera

XCG-CP510/CL

Four directional polarization signals

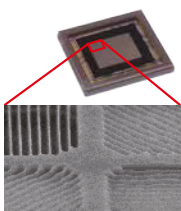

Polarizer image



SDK for Polarization Camera (for NVIDIA Jetson)

XPL-SDKLJ

Polarization processing based on polarization signals

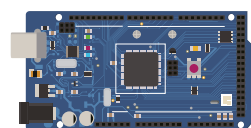

* image

Features

What is polarization?

Light is a vibrating electromagnetic wave that has four components: amplitude, wavelength, vibration direction, and radio wave direction. Of these components, Sony polarization technology focuses on vibration direction.

Unpolarized light

Normally, natural light, fluorescent light, and other kinds of light vibrate in random directions. Such light is called "natural light" or "unpolarized light" (Figure A).

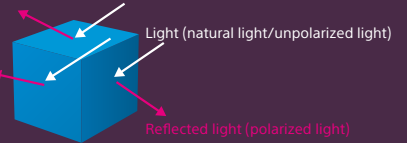

Figure A

Polarized light

Light vibrates in specific directions when it is reflected off the surface of an object. Such light is called "polarized light."

Passing light through a polarization plate can remove or extract light in specific vibration directions. Passing natural light (unpolarized light) through a polarizer can extract light polarized in specific directions (Figure B).

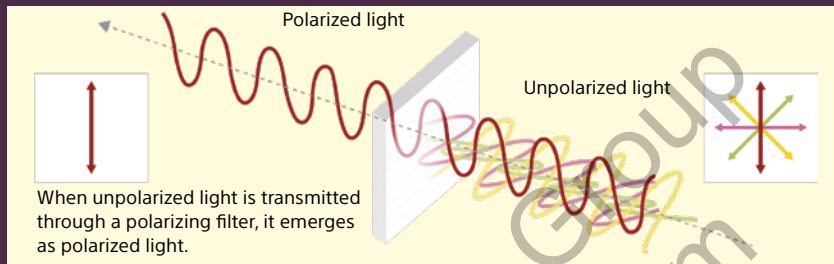

Figure B

Using the polarization phenomenon above, the shape of a subject can be estimated by analyzing luminance information from multiple images that have passed through polarization plates at different angles.

Example of an app. incorporating the polarization camera SDK (NVIDIA Jetson version) [ITS Solution Proposal]

*The image recognition AI needs to be developed by the client

Reflection (Cancel)

Reflected components calculated from four direction polarized images are removed.

Images reflected off transparent objects such as glass are reduced, making objects on the other side more visible. Reflections can be removed by both automatic calculation and manual angle adjustment.

Identification of number of individuals in vehicle



Eliminates windshield glare to clearly determine the number of individuals in a vehicle *Image

Seatbelt detection

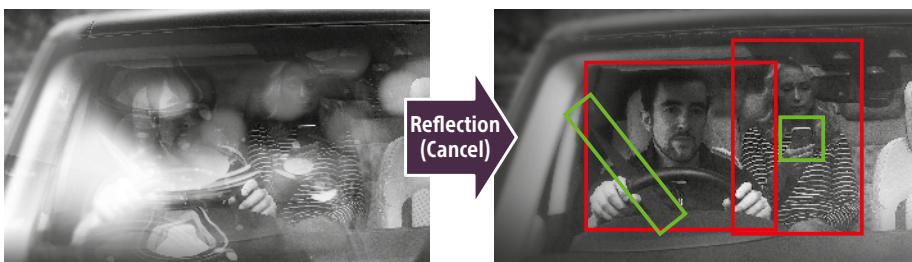

Eliminates windshield glare to detect whether individuals in a vehicle are wearing their seatbelts *Image

Why Polarization SDK for NVIDIA Jetson?

NVIDIA Jetson is widely utilized from Edge Computing point of view because it gives us following benefits.

Real Time Operation

"Recognition processing by using GPU" at edge realizes Real Time Operation.

Downsizing

It enables downsizing of the system at the edge.

Low Cost

By processing imaging data at edge, data transmission cost will be extremely low.

Applications of Polarization Cameras and SDK <Processing examples>

Degree of Polarization (DoP)

The degree of polarization (DoP) is calculated for each pixel and displayed as a degree of polarization image. This feature makes it easier to see low-contrast objects or objects that are difficult to recognize when they are the same colour as the background.



[Input Image]

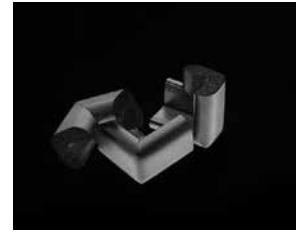

[DoP]

Surface Normal

The plane direction is estimated from the polarized state of each pixel and displayed as a surface normal image.

The object plane direction is displayed with different colours by using a colour map.

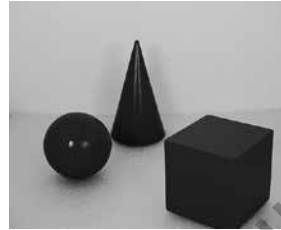

[Input Image]



[Surface Normal]

Reflection (Cancel)

Reflected components calculated from four direction polarized images are removed.

Images reflected off transparent objects such as glass are reduced, making objects on the other side more visible.

Reflections can be removed by both automatic calculation and manual angle adjustment.



[Input Image]



[Reflection (Cancel)]

Reflection (Enhance)

Reflected components calculated from four direction polarized images are enhanced.

Images reflected off transparent objects such as glass are enhanced when displayed.

A transparent object can also be made more visible.

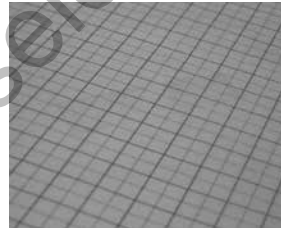

[Input Image]

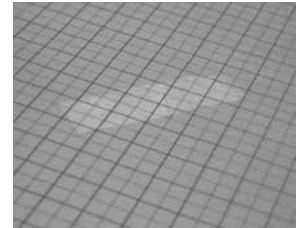

[Reflection (Enhance)]

Demosaic

Our unique demosaic function is optimally designed for the polarizer array.

The demosaic process reconstructs full resolution image from the original pixels output of 4 directional polarizer array.

With our SDK, polarization processing happens after demosaicing to create an image with a higher resolution.

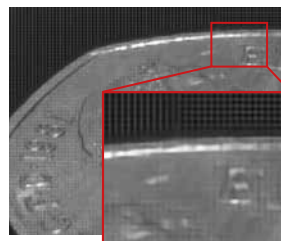

[Raw Image]



[After Demosaic]

* Expected results may not be obtained depending on measurement environments or conditions.

Performance Specifications of Jetson

Jetson AGX Xavier (16GB)

Demosaic Type	Power mode			
	MAXN	MODE_30W_*	MODE_15W	MODE_10W
Full	23.4 fps	23.4 fps	23.4 fps	not support
Quarter	23.4 fps	23.4 fps	23.4 fps	not support

*Camera : drive mode : 0, pixel format : 8bit (max. 23.4 fps)

*Measures the frame rate after polarization processing with "Reflection (Cancel)"

Jetson TX2 (8GB)

Demosaic Type	Power mode				
	MAXN	Max-Q	Max-P CORE ALL	Max-P CORE ARM	Max-P Denver
Full	23.4 fps	20.6 fps	23.4 fps	23.4 fps	not support
Quarter	23.4 fps	23.4 fps	23.4 fps	23.4 fps	not support

XCG-CP510/CL Specifications (Polarization Camera) includes license of XPL-SDKLJ

Basic Specifications	XCG-CP510/CL
B/W / Colour	B/W
Image Size	5.1 MP
Image Sensor	IMX250 (Polarization image sensor) 2/3-type CMOS Image sensors with a global shutter function (Pregius)
Number of Effective Pixels (H x V)	2,464 x 2,056
Cell Size (H x V)	3.45 μm x 3.45 μm
Standard Output Pixels (H x V)	2,448 x 2,048
Frame Rate	23 fps (8 bit, Mono/Raw)
Minimum Illumination	1.5 lx (iris: F1.4, Gain: +18 dB, Shutter: 1/23 s)
Sensitivity	F4 (400 lx, Gain: 0 dB, Shutter: 1/23 s)
SNR	More than 50 dB (Lens close, Gain: 0 dB, 8 bit)
Gain	Auto, Manual : 0 dB to 18 dB
Shutter Speed	Auto, Manual : 60 to 1/100,000 s

Camera features

Readout Modes	Normal, Partial scan	
Readout Features	Test pattern	
Synchronization	Hardware trigger, Software trigger, PTP (IEEE1588)	
Trigger Modes	OFF (Free run), ON (Edge detection, Trigger width detection), Special trigger (Burst trigger, Bulk trigger, Sequential trigger, Free set sequence)	
Userset	16	
User Memory	64 kbytes + 64 bytes x 16 ch	
Partial Scan	W (Pixel)	16 to 2,464
	H (Line)	16 to 2,056
GPO	EXPOSURE/Strobe/Sensor lead out/Trigger through/Pulse generation signal/User defined 1, 2, 3 (selectable)	
Other Features	Area gain, Defect correction, Shading correction, Temperature readout	

Interface

Video Data Output	digital Mono8, 10, 12 bit (default setting 8 bit)
Digital Interface	Gigabit Ethernet (1000BASE-T/100BASE-TX)
Camera Specification	GigE Vision® Version 2.0/1.2
Digital I/O	ISO IN (x1), TTL IN/OUT (x2, selectable)

General

Lens Mount	C mount
Flange Back	17.526 mm
Power Requirements	DC +12 V (10.5 V to 15.0 V), IEEE802.3af (37 V to 57 V)
Power Consumption	DC+12 V 3.3 W (max.)
	IEEE802.3af 3.7 W (max.)
Operating Temperature	-5 °C to +45 °C (23 °F to 113 °F)
Performance Guarantee Temperature	0 °C to 40 °C (32 °F to 104 °F)
Storage Temperature	-30 °C to +60 °C (-22 °F to +140 °F)
Operating Humidity	20% to 80% (no condensation)
Storage Humidity	20% to 80% (no condensation)
Vibration Resistance	10 G
	(20 Hz to 200 Hz 20 minutes for each direction -x, y, z)
Shock Resistance	70 G
Dimensions (W x H x D)	29 x 29 x 42 mm (1 3/16 x 1 3/16 x 1 11/16 inches) (excluding protrusions)
Mass	Approx. 65 g (2 oz)
MTBF	62,042 hours (Approx. 7.1 years)
Regulations	UL60950-1, FCC Class A, CSA C22.2-No.60950-1, IC Class A Digital Device, CE : EN61326 (Class A), AS EMC: EN61326-1, VCCI Class A, KCC, CISPR22/24+IEC61000-3-2/-3
Supplied Accessories	Lens mount cap (1), Safety Regulations (1)

XPL-SDKLJ Specifications (SDK for Polarization Camera (for NVIDIA Jetson))

	XPL-SDKLJ
Supported languages	C++
Development environment	NVIDIA Jetpack 4.3 • GCC 7.4.0 • CUDA 10 • OpenCV 4.1
Feature	Degree of Polarization Surface Normal Reflection Control Demosaic Virtual Polarizer FFC (Flat Field Correction)
Components	XPL-SDK XCG-SDK Sample viewer Sample source code API document
Device	NVIDIA Jetson TX2 series NVIDIA Jetson AGX Xavier

Camera Functions

IEEE1588 compliant

Area Gain

Defect Correction

Shading Correction

Image Flip

Temperature Readout

Bulk Trigger

Burst Trigger

Sequential Trigger

Trigger Range

For details of each function, refer to the technical manual.

Dimensions

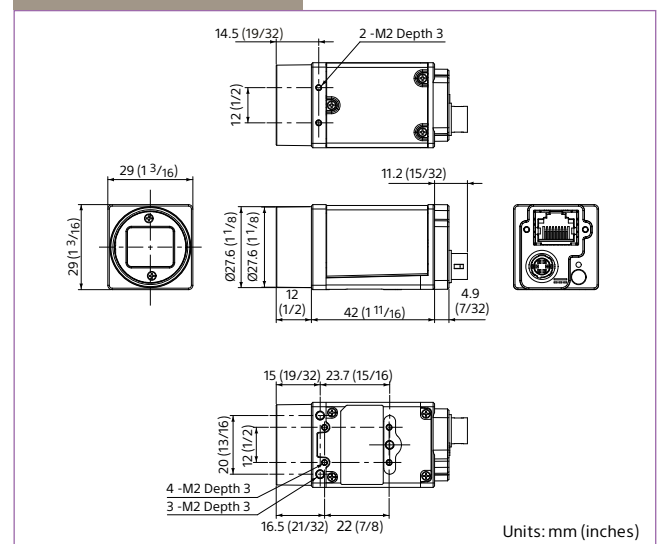

Distributed by