

# VC-50MC

50 MEGAPIXEL CMOS DIGITAL CAMERA WITH CAMERA LINK INTERFACE



The VC-50MC, the latest member of the industrial proven VC series, is a 50 megapixel resolution CMOS camera with the Camera Link interface. The VC-50MC uses the latest 50 megapixel CMOS imaging sensor (CMV50000) technology from AMS CMOSIS, and offers up to 17.5 frames per second at 7920 × 6004 resolution. Equipped with the Vieworks' innovative technologies proved by world's top FPD manufacturers, the VC-50MC camera offers not only highly uniformed images but also high speed image processing capabilities. Featured with high quality image uniformity and high resolution, this camera is ideal for demanding applications such as FPD, PCB and semiconductor inspections.

# VC-50MC

50 MEGAPIXEL CMOS DIGITAL CAMERA WITH CAMERA LINK INTERFACE

## Main Features

- \* 50 Megapixel Resolution (AMS CMOSIS)
- \* High Speed Progressive Scan CMOS Imager
- \* Global Shutter CMOS Technology
- \* Camera Link (Base / Medium / Full) Interface
- \* Pixel Defect Correction
- \* Flat Field Correction
- \* DSNU and PRNU Correction

## Applications

- \* Flat Panel Display Inspection
- \* PCB Inspection
- \* Machine Vision Inspection
- \* Microscopy and Metrology

## Specifications

Model	VC-50MC-M/C 18
Resolution (H × V)	7920 × 6004
Sensor	AMS CMOSIS CMV 50000
Sensor Size	36.43 mm × 27.62 mm (Diagonal: 45.72 mm, Optical Format: 35 mm)
Sensor Type	High Speed CMOS Image Sensor
Pixel Size	4.6 μm × 4.6 μm
Interface	Camera Link Base / Medium / Full
Max. Frame Rate (@ 85 MHz)	2 Tap: 3.5 fps
	3 Tap: 5.2 fps
	4 Tap: 7.1 fps
	8 Tap: 14.1 fps
	10 Tap: 17.5 fps
Exposure Time (1 μs step)	1 μs – 60 s
Pixel Data Format	8 bit (2/3/4/8/10 Tap), 10 bit (2/4/8 Tap), 12 bit (2/4 Tap)
Data Output Pixel Clock Speed	85 MHz / 65 MHz
Electronic Shutter	Global Shutter
Exposure Mode	Free-Run, Timed and Trigger Width
Dynamic Range	64 dB
Gain Control	1 × ~ 30 × (1/1024 step)
Black Level Control	0 ~ 256 LSB at 12 bit (1 LSB step)
Dimension / Weight	68 mm × 68 mm × 102 mm, 432 g
Temperature	Operating: -5°C ~ 40°C, Storage: -40°C ~ 70°C
Vibration / Shock	3G (20 ~ 200 Hz) XYZ / 10G 6 ms
Lens Mount	F-mount, Custom mount available upon request
Power	10 ~ 24 V DC, Typ. 9.0 W
Compliance	CE, FCC, KC
Configuration Software	Configurator

# VC-50MC

50 MEGAPIXEL CMOS DIGITAL CAMERA WITH CAMERA LINK INTERFACE

## Quantum Efficiency Curves

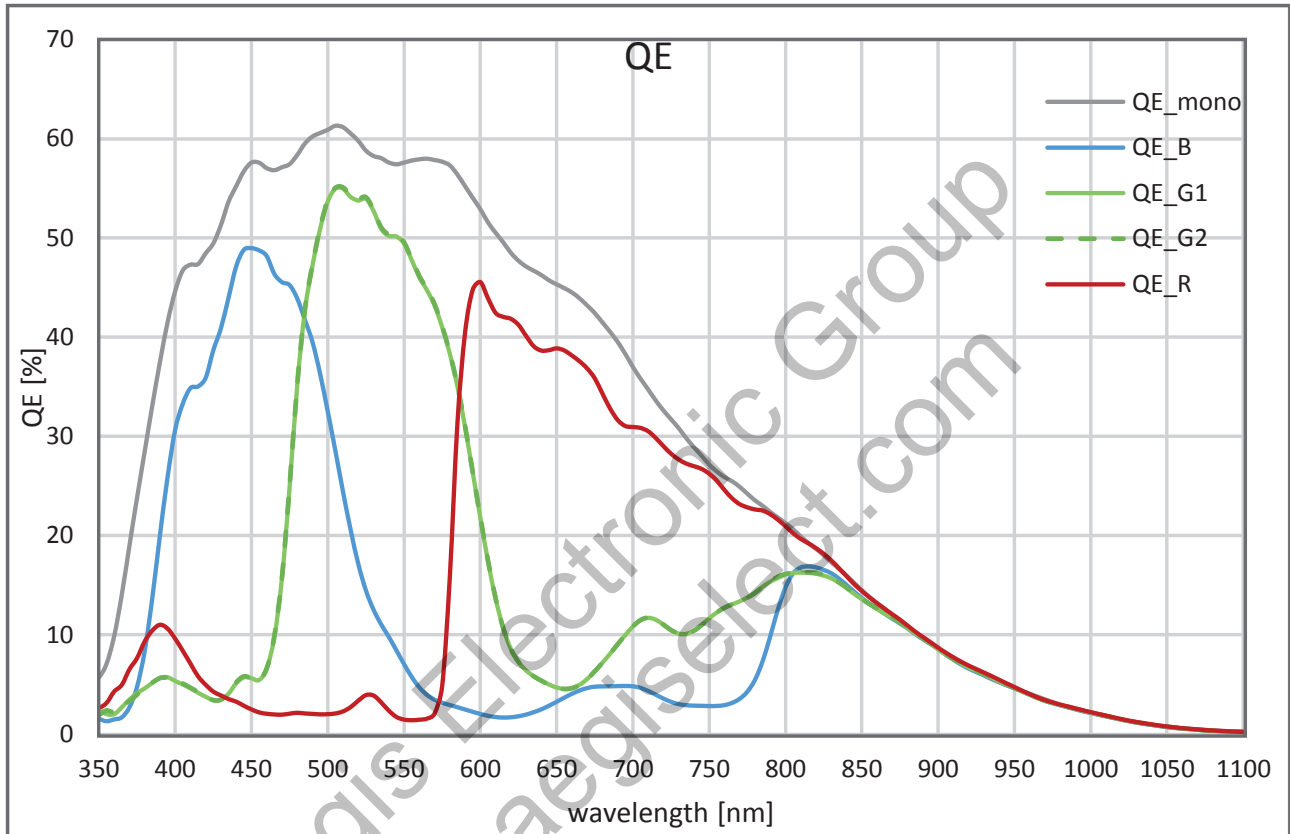

## Ordering Scheme

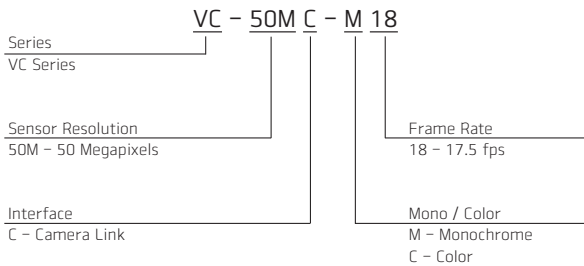

## Connector Specification

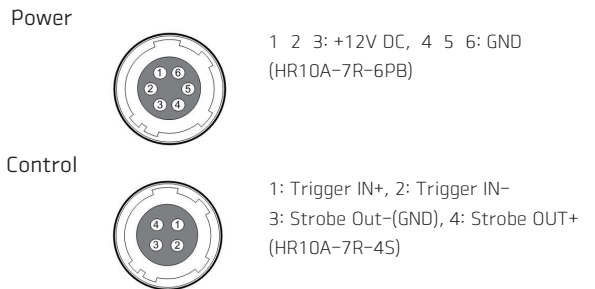

Connectors on camera body

# VC-50MC

50 MEGAPIXEL CMOS DIGITAL CAMERA WITH CAMERA LINK INTERFACE

## Mechanical Dimensions

Unit: mm

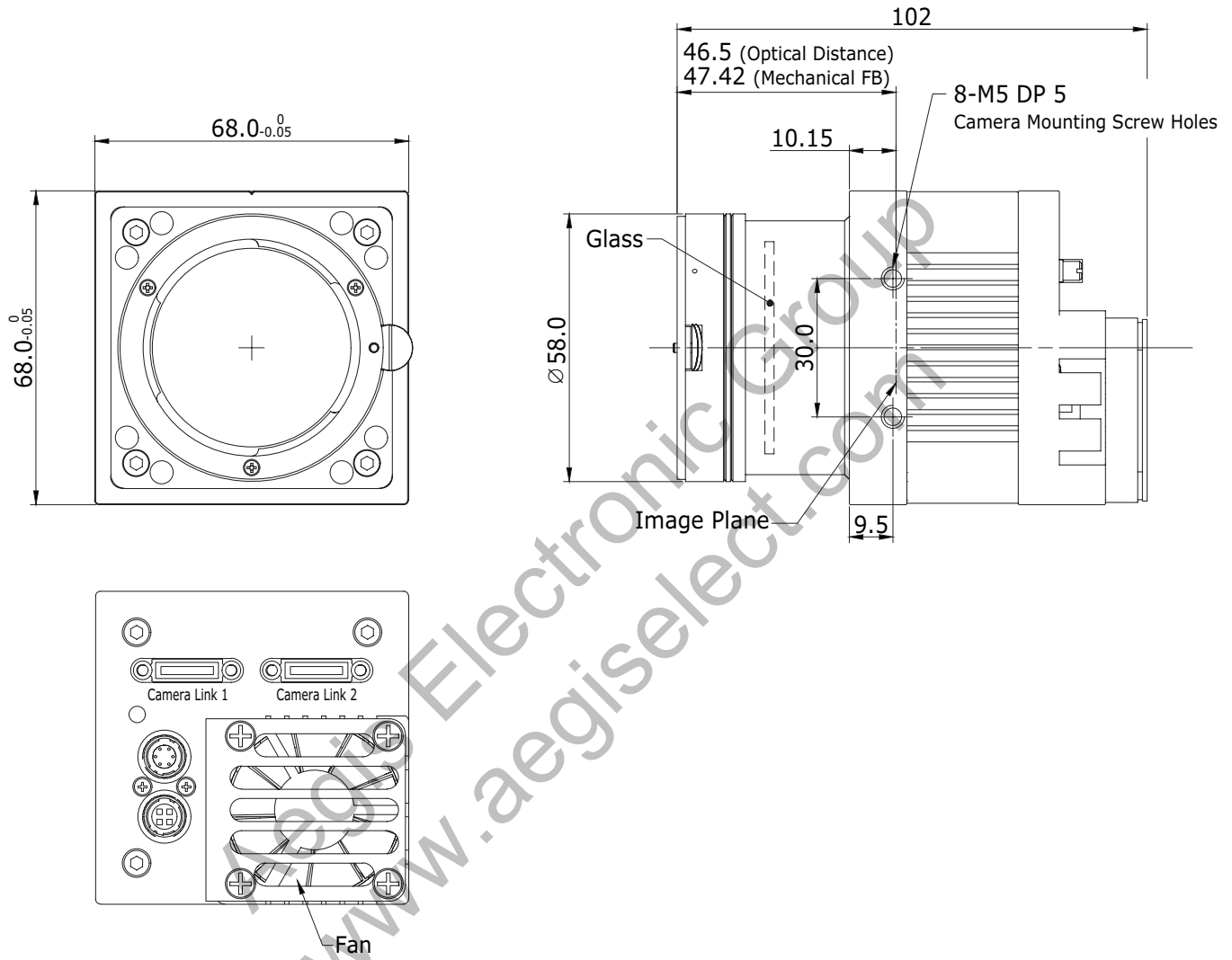

For more information please contact local distributor or visit our website at <http://www.vieworks.com>.

Reproduction in whole or in part without written permission is prohibited. Vieworks Co., Ltd. is not responsible for any technical or typographical errors and reserves the right to make changes to products, specifications and documentation without prior notice.

D-18-278