

VNP-576/1152MX2 Series

576/1152 Megapixel Pixel Shifting Camera
Equipped with Thermoelectric Peltier



CoaXPress®

The VNP-576/1152MX2, pixel shifting cameras equipped with Thermo-electric Peltier (TEC) cooled, are designed not only for applications where extremely high resolution is required but also where high quality image is essential. The TEC maintains the operating temperature of the image sensor at up to $10\pm 2^{\circ}\text{C}$ below ambient temperature to reduce noise significantly. Pixel shifting technology based on a precise piezoelectric stage allows image captures as high as 576/1152 million pixels at 3.75 fps. The CoaXPress 2.0 interface adopted by this camera supports transmitting image data at up to 50 Gbps using four coaxial cables. This new camera delivers unique and unparalleled performance in the most demanding applications such as FPD, PCB and semiconductor inspections.

VNP-576/1152MX2 Series

576/1152 Megapixel Pixel Shifting Camera Equipped with Thermoelectric Peltier

Mechanical Dimensions

Unit: mm

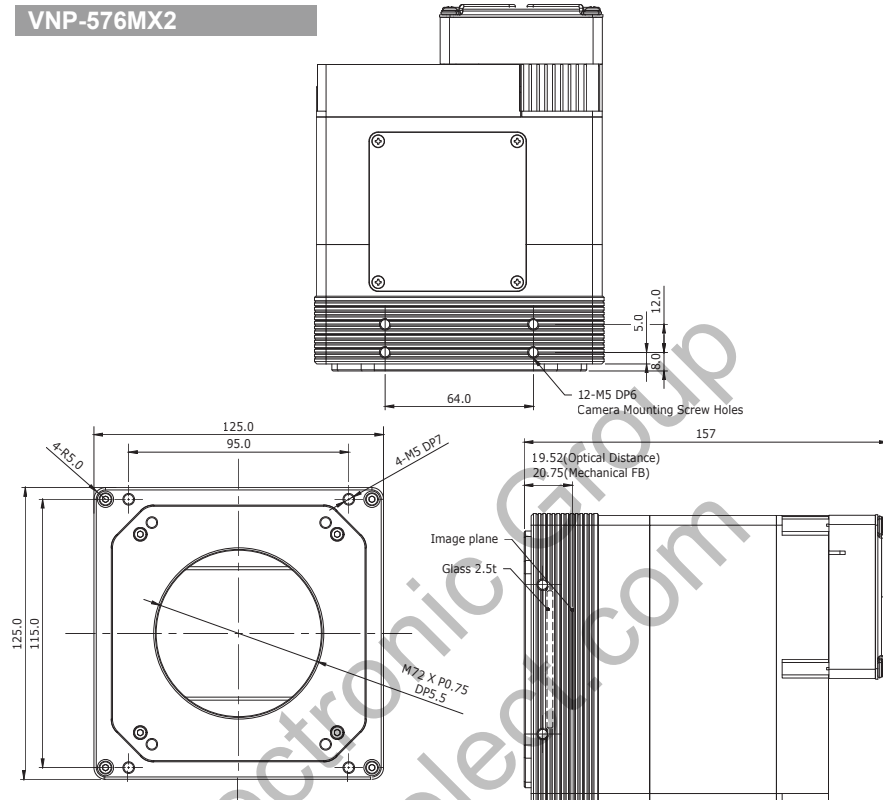

Unit: mm

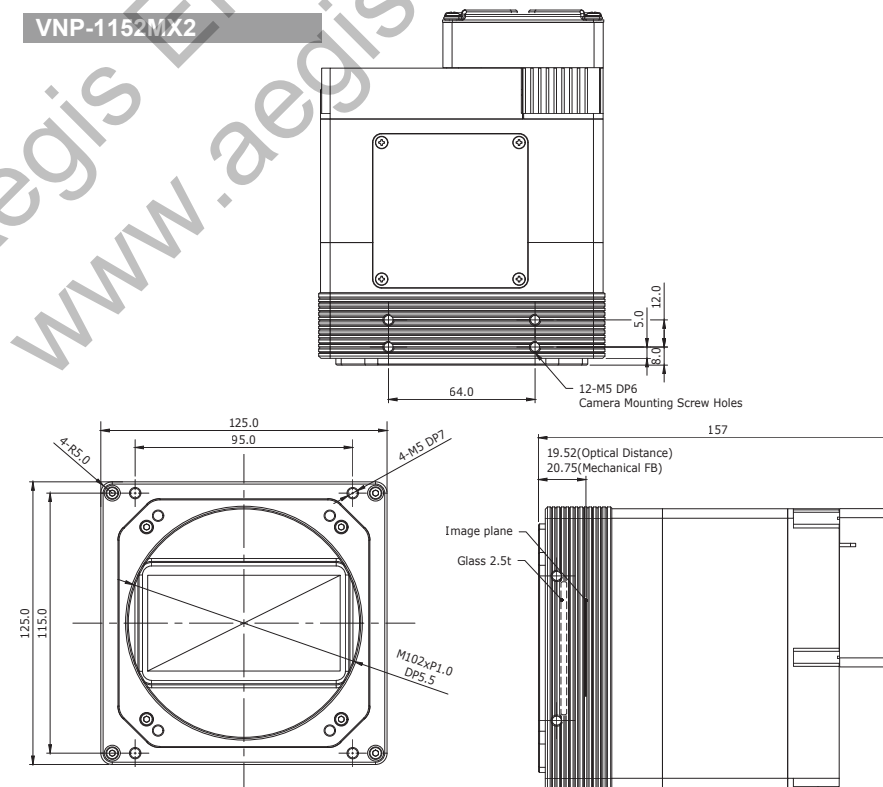

VNP-576/1152MX2 Series

576/1152 Megapixel Pixel Shifting Camera Equipped with Thermoelectric Peltier

Main Features

- Nano Stage Pixel Shifting Mechanism
- Thermoelectric Peltier Cooled – $10\pm 2^{\circ}\text{C}$ below
- CoaXPress 2.0 Interface up to 15 fps at 50 Gbps using 4 Channels
- Global Shutter CMOS Technology
- DSNU and PRNU Correction
- Pixel by Pixel PRNU Correction
- Flat Field Correction with Sequencer Control
- Hot Pixel Correction
- Defective Pixel Correction

Applications

- Flat Panel Display Inspection
- Electronics Inspection
- Semiconductor Inspection
- Document / Film Scanning

Specifications

Model		VNP-576MX2-M15K	VNP-1152MX2-M15K
Resolution (H×V)	1× (1 Shot)	12000 × 12000	24000 × 12000
	4× (4 Shot)	24000 × 24000	48000 × 24000
Sensor		Vieworks 144M Sensor	Vieworks 288M Sensor
Sensor Size (Diagonal)		42.0 mm × 42.0 mm	84.0 mm × 42.0 mm
Pixel Size		3.5 μm × 3.5 μm	
Interface		CoaXPress 2.0 (CXP-6/10/12)	
Max. Frame Rate		15 fps at 8bit	
Exposure Time (1 μs step)		1 μs – 60 s	
Pixel Data Format		Mono 8/10/12 bit	
Electronic Shutter		Global Shutter	
Trigger Synchronization		Free-Run, Hardware Trigger, Software Trigger, UserOutput0, CXP, Timer	
Dynamic Range		60 dB at 12 bit	
Gain Control	Analog	1× ~ 4×	
	Digital	1× ~ 32×	
Black Level Control		0 ~ 255 LSB at 12 bit	
Shift Range		0 ~ 14 μm, 1 nm step	
Shift Resolution		0.001 μm	
Shift Control		Manual Mode or Sequence Mode	
Shift Latency		< 5 ms	
Cooling Method		Thermoelectric Peltier Cooling	
Cooling Performance		$10\pm 2^{\circ}\text{C}$ below ambient temperature – Standard cooling with a fan	
Dimension / Weight		125 mm × 125 mm × 157 mm, 3.4 kg (with the mount)	
Temperature		Operating: 0°C ~ 40°C , Storage: -40°C ~ 70°C	
Lens Mount		M72-mount, Custom mount available upon request	M102-mount, Custom mount available upon request
Power	External	11 ~ 24 VDC	
	Dissipation	Typ. 40.0 W	
API SDK		Vieworks Imaging Solution 7.X	

VNP-576/1152MX2 Series

576/1152 Megapixel Pixel Shifting Camera Equipped with Thermoelectric Peltier

Spectral Response

* The sensitivity data may not match the measurement on the finished product necessarily because it is measured based on the wafer.

Monochrome

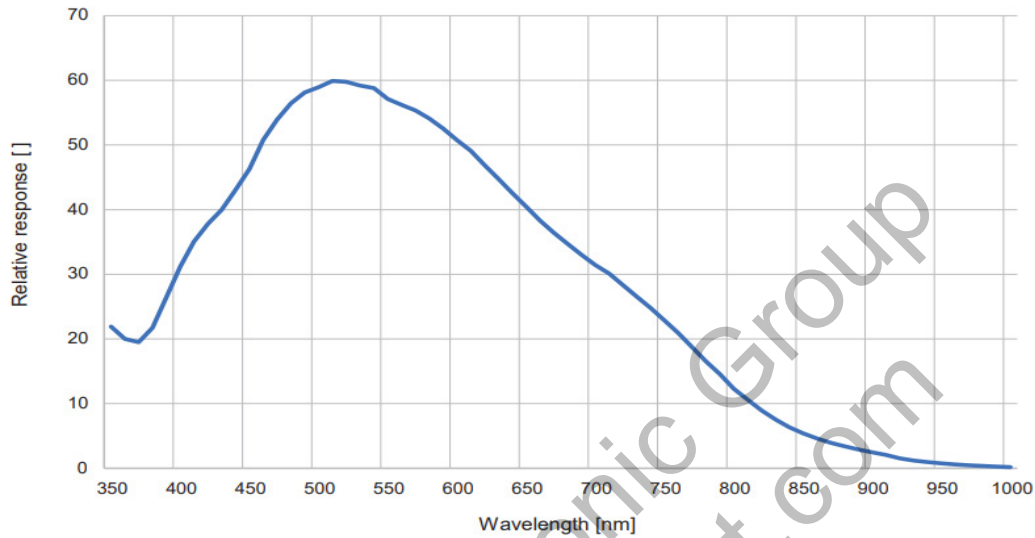

Ordering Scheme

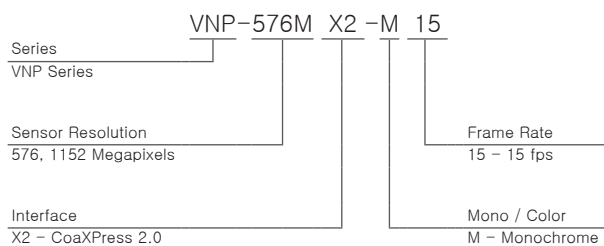

Connector Specification

Power



1, 2, 3: +12 VDC
4, 5, 6: GND
(HR10A-7R-6PB)

Control

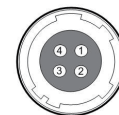

1: Trigger IN+
2: Trigger IN-
3: Strobe Out-(GND)
4: Strobe Out+
(HR10A-7R-4S)

Data Transfer / Communications

Micro-BNC

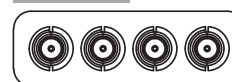

CH1: Master Connection
75 Ω, Micro-BNC (HD-BNC)

CH1 CH2 CH3 CH4

Connectors on camera body