

M5028-MPX

f=50mm F2.8

**for 2/3 Type 16 Megapixel cameras, Fixed-focal
C-Mount**

Model No.	M5028-MPX		Effective	Front	ϕ 17.5mm		
Focal Length	50mm		Lens Aperture	Rear	ϕ 11.8mm		
Max. Aperture Ratio	1:2.8		Distortion (Inf.)	2/3 Type	0.04%		
Image Circle Diameter	ϕ 11.8mm		Back Focal Length		13.2mm		
Operation Range	Iris	F2.8 - F16.0	Flange Back Length		17.526mm		
	Focus	0.2m - Inf.	Mount		C-Mount		
Control	Iris	Manual	Filter Size		M30.5 P=0.5mm		
	Focus	Manual	Dimensions		ϕ 31.8mm \times 46mm		
Operating Temperature	-10°C - +50°C		Weight		85g		
Angle of View	Sensor Size	2/3 Type		1/2 Type		1/3 Type	
	Diagonal	8.8mm \times 6.6mm	12.6°	6.4mm \times 4.8mm	9.1°	4.8mm \times 3.6mm	6.9°
	Horizontal	(ϕ 11.0mm)	10.1°	(ϕ 8.0mm)	7.3°	(ϕ 6.0mm)	5.5°
	Vertical		7.5°		5.5°		4.1°

Dimensions

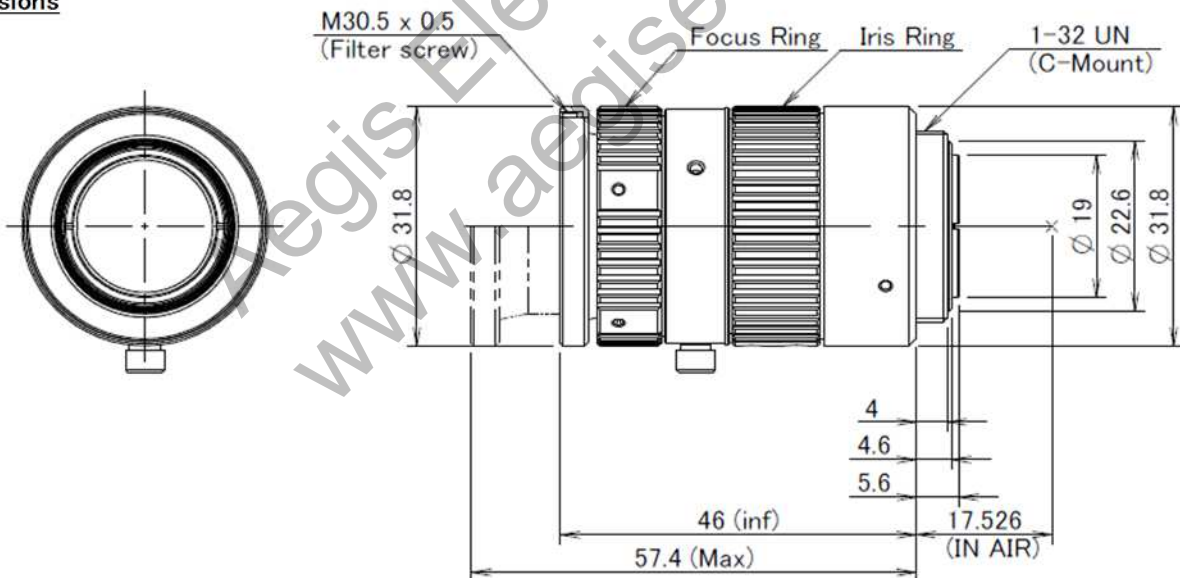

Specification is subject to change without any notice.

2024.03