

M3528-MPX

f=35mm F2.8

for 2/3 Type 16 Megapixel cameras, Fixed-focal

C-Mount

Model No.		M3528-MPX		Effective	Front	ϕ 14.0mm	
Focal Length		35mm		Lens Aperture	Rear	ϕ 12.0mm	
Max. Aperture Ratio		1:2.8		Distortion (Inf.)	2/3 Type	0.10%	
Image Circle Diameter		ϕ 11.8mm		Back Focal Length		10.9mm	
Operation Range	Iris	F2.8 - F16.0		Flange Back Length	17.526mm		
	Focus	0.15m - Inf.		Mount	C-Mount		
Control	Iris	Manual		Filter Size	M30.5 P=0.5mm		
	Focus	Manual		Dimensions	ϕ 31.8mm \times 46mm		
Operating Temperature		-10°C - +50°C		Weight	82g		
Angle of View	Sensor Size	2/3 Type		1/2 Type		1/3 Type	
	Diagonal	8.8mm \times 6.6mm	17.8°	6.4mm \times 4.8mm	13.0°	4.8mm \times 3.6mm	9.8°
	Horizontal	(ϕ 11.0mm)	14.3°	(ϕ 8.0mm)	10.4°	(ϕ 6.0mm)	7.8°
	Vertical		10.8°		7.8°		5.9°

Dimensions

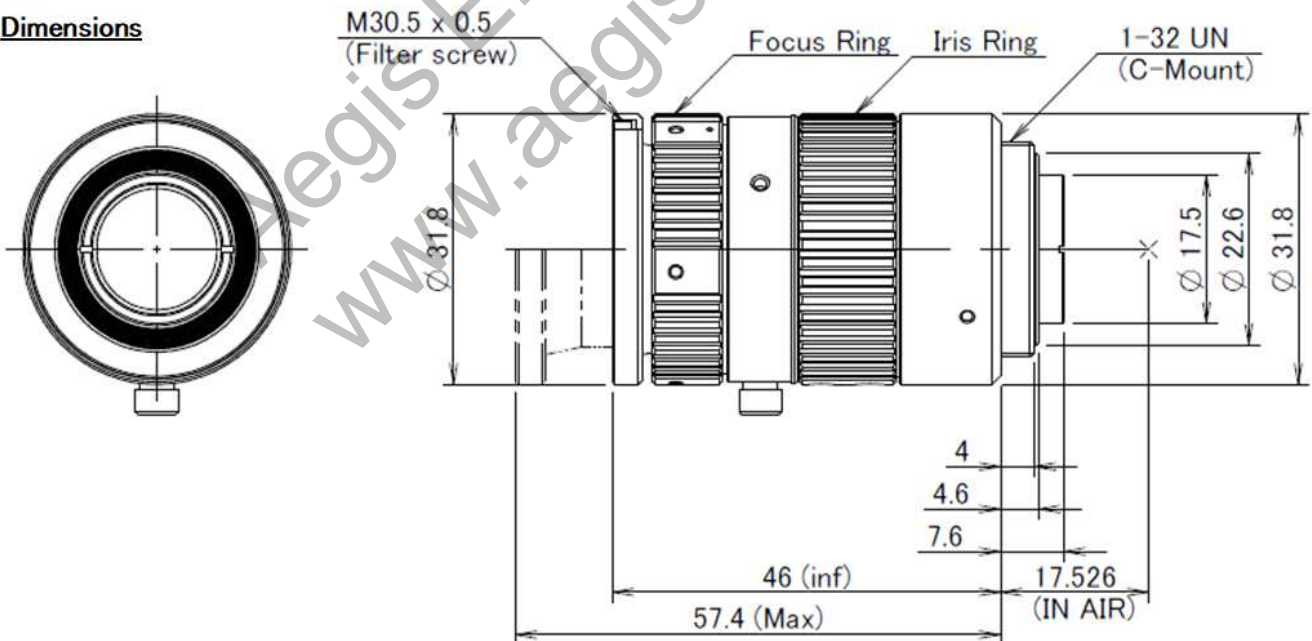

Specification is subject to change without any notice.

2024.03