

CIS

3G-SDI/HD-SDI

FULL HD CMOS Color Camera

VCC-HD3N

Product Specifications
& Operational Manual

CIS Corporation

Table of Contents

1.	Handling Precautions	2
2.	Product Outline	3
3.	Accessories	3
3.1.	Standard Accessories	3
3.2.	Optional Accessory	3
4.	Specifications	4
4.1.	General Specifications	4
5.	Part Names and Functions	6
6.	External Connector Specifications	7
6.1.	6pins Circular Connector	7
6.2.	BNC	7
6.3.	DC IRIS Connector	7
6.4.	ϕ 3.5mm 4poles (RS-232C) Connector	7
7.	GenLock	8
8.	LTC (Longitudinal Time Code)	8
9.	Defective Pixel Correction	9
9.1.	Notes for Defective Pixel Correction	9
9.2.	How to Operate Defective Pixel Correction	9
10.	Serial Communication	9
10.1.	Serial Communication Settings:	9
10.2.	Command	9
10.3.	Command List	11
10.4.	Quick Reference Table	18
10.4.1	Quick Reference Table for Gain Settings	18
10.4.2	Quick Reference Table for Shutter Settings	19
10.4.3	Actual Shutter Value Limited by Video Output Format	19
11.	How to Operate the Camera with OSD Function	20
11.1.	How to Operate OSD Menu by Remote Controller	20
11.2.	Indication of OSD Menu	20
11.3.	The List of OSD Menu	20
12.	Factory Settings	26
13.	Dimensions	27
14.	Case for Indemnity (Limited Warranty)	28
15.	CMOS Defective Pixels	28
16.	Product Support	28

1. Handling Precautions

Our warranty does not apply to damage or defects caused by neglecting the instructions and precautions explained in this manual.

The camera module must not be used for any nuclear equipment or aerospace equipment with which mechanical failure or malfunction could result in serious bodily injury or loss of human life.

Do not use the camera under conditions or environments other than those specified in this manual.

- Do not use or store the camera in dusty or humid places.
- Do not apply excessive force, vibration, or static electricity that could damage the camera. Please handle camera with care.
- Do not shoot direct images that are extremely bright (e.g., light source, sun, etc.) When extremely strong light source was shot, smear or blooming may occur. Put the lens cap on when camera is not in use.
- Follow the instructions in [Chapter 6. External Connector Specifications](#) for connecting the camera module. Improper connection may cause damages not only to the camera module but also to the connected devices.
- Confirm mutual ground potential carefully before connecting camera to other equipment. Any AC leak from the connected devices may cause damages or destroy the camera.
- Do not apply excessive voltage. (Use only the specified voltage.) Unstable or improper power supply voltage may cause damages or malfunction of the camera module.
- Since VCC-HD3N is a highly dense camera module, please apply appropriate heat dissipation such as installing a metal base to the camera.

2. Product Outline

VCC-HD3N is a 3G-SDI interface, full HD color camera using a 1/1.8" global shutter CMOS image sensor. Features CIS proprietary ISP, Clairvu™ image processing engine, for superb imaging quality and high speed processing. Supports AE, auto white balance, color correction, edge enhancement, noise reduction, gamma, GenLock, external sync, and other function. Complies with BT.2020 (Wide color gamut) and BT.2100 (Hybrid Log-Gamma). With its compact footprint, 29x29x77mm, VCC-HD3N is suitable for broadcasting, ROV, drone and vehicle, traffic surveillance, medical imaging, microscopy, and other life science equipment and systems.

Features

- CIS original Image Signal Processor, "Clairvu™" for superb imaging quality.
- Small footprint: 29mm×29mm×77mm (without projection)
- Corresponds to video output 1080 60p/59.94p/50p (3G-SDI), 1080 60i/59.94i/50i/30p/29.97p/25p/24p/23.97p (HD-SDI), 720 60p/59.94p/50p (HD-SDI).
- GenLock function (3-value analog signal or black burst)
- Supports RS-232C control.
- LTC (Longitudinal Time code)
- Supports OSD (On Screen Display) function via optional remote controller.

3. Accessories

3.1. Standard Accessories

- C/CS conversion ring (attached to the camera)
- Lens mount cap (attached to the camera)
- 6pins connector for power source

3.2. Optional Accessory

- RU-100 remote controller (OSD control, RS-232C to USB conversion).

4. Specifications

4.1. General Specifications

(1) Image sensor	Image sensor type	1/1.8" CMOS sensor (Color)	
	Effective pixels	2064(H) × 1544(V)	
	Unit cell size	3.45μm(H) × 3.45μm(V)	
	Chip size	7.121mm(H) × 5.327mm(V) (Entire pixel area) 6.624mm(H) × 3.726mm(V) (Video output area)	
(2) Resolution	1080p, 1080i:	1920(H) × 1080(V)	
	720p:	1280(H) × 720(V)	
(3) Aspect ratio	16 : 9		
(4) Video output format	1920 x 1080p @60fps(Level A)	3G-SDI	
	1920 x 1080p @60fps(Level B)	3G-SDI	
	1920 x 1080p @59.94fps(Level A)	3G-SDI	
	1920 x 1080p @59.94fps(Level B)	3G-SDI	
	1920 x 1080p @50fps(Level A)	3G-SDI	
	1920 x 1080p @50fps(Level B)	3G-SDI	
	1920 x 1080i @60fps	HD-SDI	
	1920 x 1080i @59.94fps	HD-SDI	
	1920 x 1080i @50fps	HD-SDI	
	1920 x 1080p @30fps	HD-SDI	
	1920 x 1080p @29.97fps	HD-SDI	
	1920 x 1080p @25fps	HD-SDI	
	1920 x 1080p @24fps	HD-SDI	
	1920 x 1080p @23.97fps	HD-SDI	
	1280 x 720p @60fps	HD-SDI	
	1280 x 720p @59.94fps	HD-SDI	
1280 x 720p @50fps	HD-SDI		
(5) Sync system	Internal sync. / External sync.		
(6) Video output standard	3G-SDI/HD-SDI: Y/Pb/Pr(4:2:2 10bit) BNC 75Ω terminal		
(7) Sensitivity	F5.6 2000lx		
(8) Minimum illumination	F1.4 5lx		
	Conditions: VIDEO 50%, AGC 30dB, electric shutter OFF		
(9) Power requirements	DC+9~+15V		
(10) Power consumption (typ.)	4W with DC+12V IN		
(11) Dimensions	Refer to overall dimensional drawing.		
(12) Weight	Approx. 92g		
(13) Lens mount	C/CS mount (C/CS is selectable with a conversion ring.)		
	※Please refer to the drawing.		
(14) Gain variable range	AGC (Max. gain: 0dB~48dB)	*Noise may increase with high gain setting.	
	MANUAL: 0dB~48dB		
(15) Shutter speed variable range	MANUAL: 1/13600s~1/25s		
	*Shutter slower than 1/60s will be limited depending on frame rate setting.		
(16) White balance adjustment	AUTO, AUTO(Outdoor), ATW, Preset (7 types)*, MANUAL, User preset 1~5, OnePush Preset (7 types):		
	Daylight(5500K), Cloudy(6500K), Shade(8000K), Tungsten(3200K), Fluorescent(White), Fluorescent(Neutral White), Fluorescent(Daylight)		
(17) Auto exposure detection	Average, Center-Weighted, Spot, Backlight Compensation		

(18) Flicker cancellation	ON, OFF (typ.) *Effective at 60fps, 59.94fps, 30fps, and 29.97fps.	
(19) Edge enhancement	OFF, 1~7 (typ.2)	
(20) Color correction	Standard, Fluorescent Light, Tungsten Lamp	
(21) Saturation adjustment	0% (B/W) ~ 100% (typ.) ~ 200%	
(22) Color saturation suppression	OFF, 1~7 (typ.5)	
(23) Noise reduction	ON, OFF	
(24) Gamma (Contrast)	BT.709 -2, BT.709 -1, BT.709, BT.709 +1, BT.709 +2	
(25) Master pedestal	-100 ~ 0 ~ +100	
(26) Pedestal(R,G,B)	RGB independent: -100 ~ 0 (typ.) ~ +100	
(27) Color balance	RGB independent: 50 ~ 100 (typ.) ~ 150	
(28) Pixel defect correction (white spot)	Corrected upon shipment.	
(29) LTC	OFF, ON Accepts external SMPTE Time code in the LTC IN terminal. (Supports resetting internal self-counting time code.)	
(30) Camera preset settings	1, 2, 3, 4 (Four kinds of preset to store.)	
(31) DC IRIS output	Auto/Open switchable. Can be used with electric shutter. (with priority to electric shutter)	
(32) Remote control communications	Supports RS-232C communications via ϕ 3.5 plug (4 poles) to control camera settings. Supports OSD function with connecting the optional remote controller, RU-100.	
(33) Safety/Quality standards	Conform to UL Standard.	
	CE EMC 2014/30/EU Emission: EN61000-6-3:2007+A1:2011 Immunity: EN61000-6-2:2005	
	RoHS 2011/65/EU EN50581(RoHS2)	
	FCC Class A Digital Device This device complies with Part 15 of the FCC Rules. Operation is subject to the following two conditions: (1) this device may not cause harmful interference, and (2) this device must accept any interference received, including interference that may cause undesired operation.	
(34) Durability	Vibration	
	Acceleration:	98m/s ² (10G)
	Frequency:	20~200 Hz
	Direction:	X, Y, and Z 3 directions
	Testing time:	120 minutes for each direction
Shock	No malfunction with 980m/s ² (100G) for \pm X, \pm Y, and \pm Z, 6 directions without packaging.	
(35) Operational conditions	Operational temperature: -5 ~ +45°C Humidity: 20 ~ 80%RH with no condensation.	
(36) Storage conditions	Storage temperature: -25 ~ +60°C Humidity: 20 ~ 80%RH with no condensation.	

[3G-SDI output Level A and Level B]

The difference between Level A and Level B is the way of mapping Y signal and Cb/Cr signal onto 3G-SDI standard signal. The difference does not affect the resolution of the video signal. Some 3G-SDI receivers correspond to either Level A or B, whereas other receivers correspond to both Levels, so please set the camera mode to match your 3G-SDI receiver.

5. Part Names and Functions

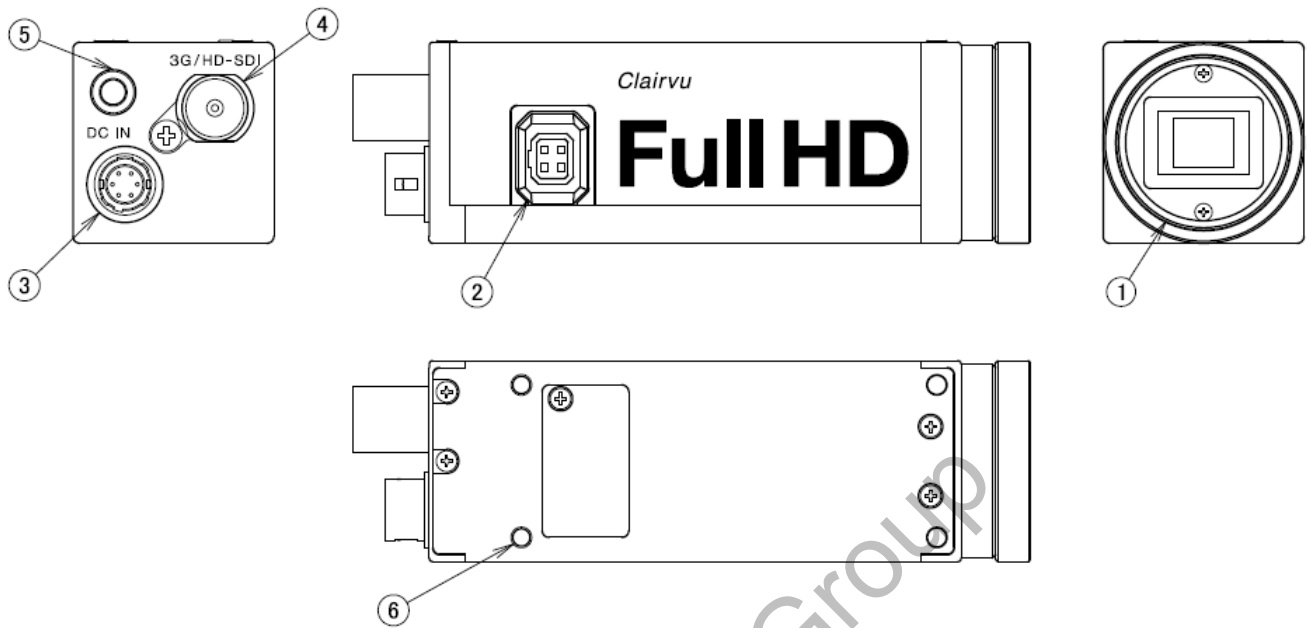

① C/CS mount

To mount a C mount lens, keep the C/CS conversion ring attached. (This product is shipped from our factory with conversion ring attached.) To mount a CS mount lens, remove the C/CS conversion ring.

Screw length from the lens mount surface must be 6mm or less, and protrusion of the lens must be 8mm or less. When a lens is not mounted, put the attached lens mount cap on.

② Connection terminal for DC-IRIS lens

③ Connector for power input, GenLock, and LTC signal input

Please refer to the external connector pin assignment.

④ Video signal output

With a BNC cable, connect to a 3G-SDI input monitor or HD-SDI input monitor.

Please use BNC cable with high frequency characteristics correspond to 3G-SDI or HD-SDI.

⑤ $\phi 3.5(4 \text{ poles})$ connector (RS-232C)

Connector for RS-232C signals.

Please refer to the external connector pin assignment to connect.

*Do not connect to any audio equipment such as earphones and headsets. Connecting to such equipment may cause malfunction.

⑥ Screw holes for camera installation

Screw holes to install camera.

Please note that depth of the front screw holes and the rear screw holes are different.

6. External Connector Specifications

6.1. 6pins Circular Connector

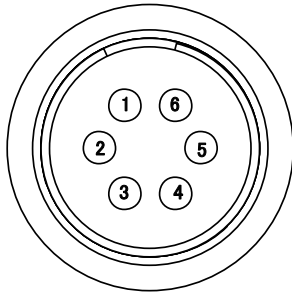

Model name: HR10-7R-6PA (HIROSE)

Pin No.	Description
1	Power IN DC+12V
2	EXT SYNC IN
3	LTC IN
4	N.C.
5	GND
6	GND

6.2. BNC

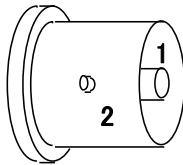

Model name: BCJ-BPLHA (CANARE)

Pin No.	Description
1	3G-SDI/HD-SDI output
2	GND

6.3. DC IRIS Connector

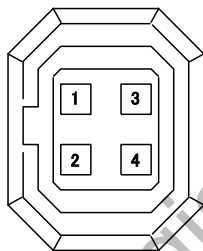

Model name: D4-156N-200A (Technical Electron. Co. LTD)

Pin No.	Description
1	DAMP-
2	DAMP+
3	DRIVE+
4	DRIVE-(GND)

6.4. φ3.5mm 4poles (RS-232C) Connector

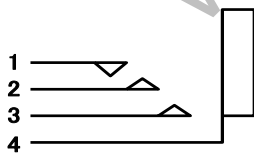

Model name: MJ

Pin No.	Description
1	Power(+5V) *For optional
2	TXD(Camera)
3	RXD(Camera)
4	GND

Connection of φ3.5 (4 poles) connector (RS-232C)

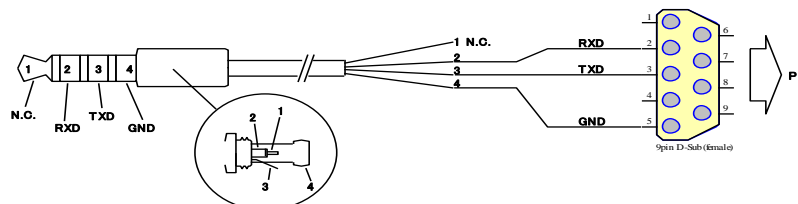

7. GenLock

- Input analog external sync signals (black burst or 3-value SYNC) to the EXT SYNC IN terminal of 6pins connector to enable GenLock function.
- The corresponding external sync signals depend on its video output format, therefore, please refer to the chart below and input appropriate signals.

		EXT SYNC IN				
CAMERA FORMAT	1080p60A			1080i60	720p60	1080p30
	1080p59.9A	NTSC		1080i59.9	720p59.9	1080p29.9
	1080p50A		PAL	1080i50	720p50	1080p25
	1080p60B			1080i60	720p60	1080p30
	1080p59.9B	NTSC		1080i59.9	720p59.9	1080p29.9
	1080p50B		PAL	1080i50	720p50	1080p25
	1080i60			1080i60	720p60	1080p30
	1080i59.94	NTSC		1080i59.9	720p59.9	1080p29.9
	1080i50		PAL	1080i50	720p50	1080p25
	1080p30			1080i60	720p60	1080p30
	1080p29.9	NTSC		1080i59.9	720p59.9	1080p29.9
	1080p25		PAL	1080i50	720p50	1080p25
	1080p24					1080p24
	1080p23					1080p23.9
	720p60			1080i60	720p60	1080p30
	720p59.9	NTSC		1080i59.9	720p59.9	1080p29.9
	720p50		PAL	1080i50	720p50	1080p25

[Note]

- Input Black Burst signals for NTSC/PAL signals. Input 3-value SYNC signals for other than NTSC/PAL signals.
- EXT SYNC IN is terminated with 75Ω. (When camera power is OFF, mode becomes high impedance.)
- When an external signal specified in the chart above is input, the camera will automatically be in external sync mode.
- When there is no external signal, the camera will operate in internal sync mode.
- Disturbance images occur immediately after inputting external signals, however this is normal.
- Disturbance images may occur or there will be no image when inputting a signal other than those specified in the chart above to the EXT SYNC IN terminal.

8. LTC (Longitudinal Time Code)

- Supports Time code insertion to 3G/HD SDI signals.
- Input LTC signals (time code) to the LTC IN terminal of the 6pins connector to insert external time code.

When there is no signal input to the LTC IN terminal, user can insert internal time code.

Internal time code starts with 00:00:00.00 when power is ON, and when signals are input to the LTC IN terminal, time code switches to the external time code. Under this condition, if no signal is input to the LTC IN terminal, internal time code starts.

Signal format: SMPTE Timecode

Signal level: 0.5~2[Vp-p]

9. Defective Pixel Correction

9.1. Notes for Defective Pixel Correction

- When user executed and saved defective pixel correction, INIT command (SU 700) does not restore defective pixel correction data since the values corrected upon shipment are over-written.
- When saved after executing INIT command, the selected preset values (CameraSetting) will be over-written with factory setting data. If you do not want to overwrite preset values, load preset values before saving. Also, defective pixels data will be saved in one place regardless of its preset number.
- Defective pixel correction only correspond to white defects. Also, please note that all white defects are not necessarily able to be corrected.
- Correction result may not always be the same due to temperature, noises, and other causes.
- If the light leakage occurs to the image sensor, or neglect instructions explained above, it may cause not only incorrect pixel defect correction, but also failure of acquiring proper images.

9.2. How to Operate Defective Pixel Correction

- ① Execute INIT command to restore the camera to factory setting data.
- ② Put the lens mount cap on to avoid light leakage to the image sensor, then wait for 5 seconds.
- ③ Execute defective pixel correction, and save. (Please make sure to execute with the lens mount cap on).

10. Serial Communication

10.1. Serial Communication Settings:

Baud rate : 9600 bps
 Data : 8bit
 Start bit : 1bit
 Parity : None
 Stop bit : 1bit

10.2. Command

Command	Parameter 1	Parameter 2	Description
GU	Command number	Normally none	To obtain information from the camera. ("G" for "Get")
SU	Command number	Data 1, Data 2 ...	To send settings and instructions to the camera. ("S" for "Set")
SAVE	None	None	To save camera settings.
INIT	None	None	To initialize camera settings.

[How to set a command]

- Separate between a command and a parameter by single space.
- Input command in upper-case letter.
- Parameters start with 0x are regarded as hexadecimal, parameters start with 0 are regarded as octal, and others are regarded as decimal.
- Do not input other than the number (0~9), decimal point, and hexadecimal (0~9 and a~f).
- Commands analyze parameters from the head to identifiable letters.
- From the head of the input character to the linefeed code (¥r) (or (¥n)) is defined as a single serial command.
- Camera receives the returned command from host, and echoes the command back. At this time, linefeed codes will be [¥r] and [¥n].

- Determine the end of the command with >[sp].
- The next command must be issued after completion of the prior command.

【Example of GU command】

To get the information of the address 10

[Send]	GU[sp]10[¥r]	
[Returned value]	GU[sp]10[¥r][¥n]	[Echo back]
[Returned value]	50[¥r][¥n]	[Obtained data + Linefeed]
[Returned value]	[¥r][¥n]	[Linefeed]
[Returned value]	>[sp]	[Prompt + Space]

[¥r]=CR(0x0D)
[¥n]=LF(0x0A)
[sp]=Space(0x20)

【Example of SU command】

To set 30 to the address 10

[Send]	SU[sp]10[sp]30[¥r]	
[Returned value]	SU[sp]10[sp]30[¥r][n]	[Echo back]
[Returned value]	[¥r][¥n]	[Linefeed]
[Returned value]	>[sp]	[Prompt + Space]

【Example of SAVE command】

[Send]	SAVE[¥r]	
[Returned value]	SAVE[¥r][¥n]	[Echo back]
[Returned value]	[¥r][¥n]	[Linefeed]
[Returned value]	>[sp]	[Prompt + Space]

Aegis Electronic Group
www.aegiselect.com

10.3. Command List

Video Format				
Function	Address	Set Value	Initial Value	Description
Video Format	1	0: 1080p 60fps (LevelA)	6	This is to set video output format.
		1: 1080p 59.94fps (LevelA)		
		2: 1080p 50fps (LevelA)		
		3: 1080p 60fps (LevelB)		
		4: 1080p 59.94fps (LevelB)		
		5: 1080p 50fps (LevelB)		
		6: 1080i 60fps		
		7: 1080i 59.94fps		
		8: 1080i 50fps		
		9: 1080p 30fps		
		10: 1080p 29.97fps		
		11: 1080p 25fps		
		12: 1080p 24fps		
		13: 1080p 23.97fps		
		14: 720p 60fps		
		15: 720p 59.94fps		
16: 720p 50fps				

AE related				
Function	Address	Set Value	Initial Value	Description
Gain Mode	2	0: Manual 1: Auto	1	This is to set gain control mode.
Gain Value	3	Magnification×0x10000 x1(0dB) ~ x251(48dB)	0x10000 (65536)	This is to set gain value when gain mode is Manual. e.g.) To set x2 (approx. 6dB): SU 3 0x00020000 ※Please refer to Section 10.4.1 Quick Reference Table for Gain Settings.
Gain Max Value	4	Magnification×0x10000 x1(0dB) ~ x251(48dB)	0x200000 (2097152)	This is to set the max gain value when gain mode is Auto. ※Please refer to Section 10.4.1 Quick Reference Table for Gain Settings.
Shutter Mode	5	0: Manual 1: Auto	1	This is to set shutter control mode.
Shutter Value	6	Exposure time [s]×0x100000 1/25s ~ 1/13600s	0x4444 (17476) 1/60s	This is to set shutter value (exposure time) when shutter mode is Manual. Shutter slower than 1/60s will be limited depending on frame rate setting. ※Please refer to Section 10.4.2 Quick Reference Table for Shutter Settings. (*1)

Shutter Limit	7	The 1 st Param: Max value Exposure time [s]×0x100000 1/25s ~ 1/13600s	0x4444 (17476) 1/60s	This is to set shutter limit when shutter mode is Auto. e.g.)To set Max=1/60s, Min=1/8000s: SU 7 0x4444 0x83 Shutter slower than 1/60s will be limited depending on frame rate setting. ※ Max<Min is invalid. ※ Please refer to Section 10.4.2 Quick Reference Table for Shutter Settings . (*1)
		The 2 nd Param: Min value Exposure time [s]×0x100000 1/25s ~ 1/13600s	0x4D (77)	
Metering Mode	8	0: Average	1	This is to set metering mode.
		1: Center-Weighted		
		2: Spot		
		3: Backlight Compensation		
Spot Block	9	The 1 st Param: X value: 0~15	7	This is to set X, Y, W, and H values for Spot metering. X: Far left of metering field Block, X coordinate Y: Top of metering field Block, Y coordinate W: Width of metering field (number of block) H: Height of metering field (number of block) e.g.) SU 9 7 7 2 2
		The 2 nd Param: Y value: 0~15	7	
		The 3 rd Param: W value: 1~16	2	
		The 4 th Param: H value: 1~16	2	
AE Speed	10	0~15	10	This is to set AE convergence speed.
Exposure Compensation Value	11	0(-18dB) ~ 18(0dB) ~36(18dB) /per 1dB	18	This is to set exposure compensation value.
Flicker Cancel	12	0: OFF	0	This is to set ON/OFF of flicker cancel. (*2)
		1: ON		
Gain Value, Plus Minus	13	-1: decrease 1dB 1: increase 1dB	None	This is to change gain value by ±1dB from the current setting. Valid when gain mode is Manual. (Write Only)
Shutter Speed, Plus Minus	14	-1: decrease 1step (1/4EV) 1: increase 1step (1/4EV)	None	This is to change shutter speed by ±1 step (1/4EV) from the current value. When shutter speed decreases by 1step, shutter value becomes bigger. Valid when shutter mode is Manual. (Write Only) (*1)

(*1) There is a difference between set shutter value and the actual shutter value. Please refer to [Section 10.4.3 Actual Shutter Value Limited by Video Output Format](#).

(*2) Flicker cancel function is invalid when frame rate is either 50fps, 25fps, 24fps, or 23.97fps regardless of the camera settings.

WB related				
Function	Address	Set Value	Initial Value	Description
WB Mode	20	0: Auto	0	This is to set White Balance (WB) mode.
		1: Auto (Outdoor)		
		2: DayLight (Sunlight)		
		3: Cloudy		
		4: Shade		
		5: Tungsten (Light bulb)		
		6: Flw (Fluorescent light/ White)		
		7: Fln (Fluorescent light/ Daytime white)		
		8: Fld (Fluorescent light/Daylight color)		
		9: Auto (ATW)		
		10: OnePush		
		11: Manual		
		12: Preset1		
		13: Preset2		
		14: Preset3		
		15: Preset4		
16: Preset5				
Preset	21	1: Preset1	None	This is to store the current white balance value as preset value. To save the stored value, please execute SAVE. (Write Only)
		2: Preset2		
		3: Preset3		
		4: Preset4		
		5: Preset5		
Blue Gain	22	0~800(%)	190	This is to set blue gain when WB mode is
Red Gain	23	0~800(%)	199	This is to set red gain when WB mode is Manual and Preset.
One Push Trigger	24	1: Trigger Start	None	This is to start trigger when WB mode is One Push. (Write Only)

Image Quality related				
Function	Address	Set Value	Initial Value	Description
Edge Level	30	0: Off	2	This is to set the strength of edge enhancement.
		1:1		
		2:2		
		3:3		
		4:4		
		5:5		
		6:6		
Gamma	35	0: BT.709 -2	2	This is to set gamma type and contrast. 0~4 are the curves that comply with BT.709.
		1: BT.709 -1		
		2: BT.709		
		3: BT.709 +1		
		4: BT.709 +2		
Master Pedestal	37	-100~+100	0	This is to set Master pedestal.
Red Pedestal	38	-100~+100	0	This is to set Red pedestal.
Green Pedestal	39	-100~+100	0	This is to set Green pedestal.
Blue Pedestal	40	-100~+100	0	This is to set Blue pedestal.
Red Balance	41	0~200	100	This is to set Red balance.
Green Balance	42	0~200	100	This is to set Green balance.
Blue Balance	43	0~200	100	This is to set Blue balance.
Color Saturation	45	0~200	100	This is to set color saturation.
Noise Reduction	50	0: Off 1: On	0	This is to set the level of noise reduction.
Color Correction	52	0: Auto	0	This is to set color correction.
		1: Standard		
		2: Fluorescent light		
		3: Tungsten lamp		
Color Suppression	53	0~7	5	This is to set color suppression.

Lens Control related				
Function	Address	Set Value	Initial Value	Description
DC Iris Mode	61	0: Open	0	Set to Open when a DC Iris Lens is NOT in use. (*3)
		1: Auto		
DC Iris Response Speed	77	0: Low	1	This is to set the speed of DC Iris response when DC Iris Mode is Auto. The higher the value, the slower the DC Iris response speed becomes.
		1: Mid		
		2: High		

(*3) When shooting a high luminance object with DC iris function, hunting may occur under some conditions.

In such cases, please adjust DC Iris Response Speed or Exposure Compensation Value.

©2018 CIS Corporation. All rights reserved.

OSD related				
Function	Address	Set Value	Initial Value	Description
OSD UP button	90	0: 1 push 1: continuous push	None	Commands to operate OSD. Send commands every 60ms for continuous push.
OSD DOWN button	91	0: 1 push 1: continuous push	None	
OSD R button	92	0: 1 push 1: continuous push	None	
OSD L button	93	0: 1 push 1: continuous push	None	
OSD CENTER button	94	0: 1 push 1: continuous push	None	This is to use as Set button.
Menu Color	95	0: Black 1: Blue 2: Red 3: Magenta 4: Green 5: Cyan 6: Yellow 7: White	7	This is to set the text color of OSD menu.
Select Color	96	0: Black 1: Blue 2: Red 3: Magenta 4: Green 5: Cyan 6: Yellow 7: White	5	This is to set the selected letter's font color of OSD menu. If user specifies the same color as the text color, error will occur because the selected letters cannot be recognized.

Others				
Function	Address	Set Value	Initial Value	Description
Camera Setting Store	100	0~3	0 at initial operation	User can store four kinds of camera settings. Execute SAVE command to save the registered values. The stored data and setting values are not subject to INIT command.
Camera Setting Load	101	0~3	0 at initial operation	This is to readout and reflect the registered values set by Camera Setting Store to the camera. Settings values are not subject to INIT command. *When executed Camera Setting Store, the setting value will become the value set by Camera Setting Store.
LTC OFF/ON	103	0: OFF 1: ON	0	This is to set OFF/ON of LTC signals insertion.
LTC Reset	104	1: Reset		This is to reset internal free-run timer of LTC. (Write only)
VPHASE	106	-1024~1023	0	This is to set V phase of GenLock.
HPHASE	107	-2048~2047	0	This is to set H phase of GenLock. (*4)
H Flip	110	0: OFF 1: ON	0	This is to set horizontal flip of the output image.
V Flip	111	0: OFF 1: ON	0	This is to set vertical flip of the output image.

(*1) Some differences may occur to the setting values by rebooting power, changing format, and V/H phase adjustment.

No Command Numbers				
Function	Address	Set Value	Initial Value	Description
SAVE	None	None	None	This is to save camera settings. SAVE with capital letters. *Only single table can be saved with defective pixels correction.
INIT	None	None	None	This is to initialize camera settings. Execute INIT with capital letters.
GVI	None	1: Microcomputer version 2: FPGA version	None	This is to obtain firmware version. The letter strings such as 0.1 will be responded.
SDDW	None	512	0	This is to start defective pixel correction. (Please refer to Section 9. Defective Pixel Correction for how to use this function.)

10.4. Quick Reference Table

10.4.1 Quick Reference Table for Gain Settings

	Magnification	dB	GainValue (Magnification×0x10000)	
			DEC	HEX
0	1.000	0.000	65536	00010000
1	1.122	1.003	73561	00011F59
2	1.260	2.007	82570	0001428A
3	1.414	3.010	92681	00016A09
4	1.587	4.014	104031	0001965F
5	1.782	5.017	116771	0001C823
6	2.000	6.021	131072	00020000
7	2.245	7.024	147123	00023EB3
8	2.520	8.027	165140	00028514
9	2.828	9.031	185363	0002D413
10	3.175	10.034	208063	00032CBF
11	3.564	11.038	233543	00039047
12	4.000	12.041	262144	00040000
13	4.490	13.045	294246	00047D66
14	5.040	14.048	330280	00050A28
15	5.657	15.051	370727	0005A827
16	6.350	16.055	416127	0006597F
17	7.127	17.058	467087	0007208F
18	8.000	18.062	524288	00080000
19	8.980	19.065	588493	0008FACD
20	10.079	20.069	660561	000A1451
21	11.314	21.072	741455	000B504F
22	12.699	22.076	832255	000CB2FF
23	14.254	23.079	934175	000E411F
24	16.000	24.082	1048576	00100000
25	17.959	25.086	1176986	0011F59A
26	20.159	26.089	1321122	001428A2
27	22.627	27.093	1482910	0016A09E
28	25.398	28.096	1664510	001965FE
29	28.509	29.100	1868350	001C823E
30	32.000	30.103	2097152	00200000
31	35.919	31.106	2353974	0023EB36
32	40.317	32.110	2642246	00285146
33	45.255	33.113	2965821	002D413D
34	50.797	34.117	3329021	0032CBFD
35	57.018	35.120	3736700	0039047C
36	64.000	36.124	4194304	00400000
37	71.838	37.127	4707947	0047D66B
38	80.635	38.130	5284492	0050A28C
39	90.510	39.134	5931642	005A827A
40	101.594	40.137	6658043	006597FB
41	114.035	41.141	7473400	007208F8
42	128.000	42.144	8388608	00800000
43	143.675	43.148	9415894	008FACD6
44	161.270	44.151	10568984	00A14518

©2018 CIS Corporation. All rights reserved.

45	181.019	45.154	11863283	00B504F3
46	203.187	46.158	13316085	00CB2FF5
47	228.070	47.161	14946800	00E411F0
48	251.189	48.000	16461899	00FB304B

10.4.2 Quick Reference Table for Shutter Settings

Exposure time [s]	ShutValue (Exposure time[s]×0x100000)	
	DEC	HEX
1/25	41943	0000A3D7
1/30	34952	00008888
1/60	17476	00004444
1/90	11650	00002D82
1/100	10485	000028F5
1/125	8388	000020C4
1/180	5825	000016C1
1/250	4194	00001062
1/350	2995	00000BB3
1/500	2097	00000831
1/725	1446	000005A6
1/1000	1048	00000418
1/1500	699	000002BB
1/2000	524	0000020C
1/3000	349	0000015D
1/4000	262	00000106
1/6000	174	000000AE
1/8000	131	00000083
1/9600	109	0000006D
1/11200	94	0000005E
1/13600	77	0000004D

10.4.3 Actual Shutter Value Limited by Video Output Format

Set Value	Shutter Value	Actual shutter value							
		60fps	59.94fps	50fps	30fps	29.97fps	25fps	24fps	23.976fps
1/4000	262	1/3988	1/3984	1/4084	1/3988	1/3984	1/3808	1/4238	1/4234
1/4800	218	1/4847	1/4842	1/4778	1/4522	1/4518	1/5222	1/5027	1/5023
1/5600	187	1/5660	1/5654	1/5756	1/5222	1/5217		1/6177	1/6172
1/6800	154	1/6800	1/6794	1/7237	1/7562	1/7555	1/6412	1/8010	1/8003
1/8000	131	1/7562	1/8508	1/8306			1/8306		
1/9600	109	1/9745	1/9736	1/9745	1/9745	1/9736	1/11787	1/11389	1/11379
1/11200	94	1/11389	1/11379	1/11787					
1/13600	77	1/13701	1/13690	1/14911	1/13701	1/13689			

11. How to Operate the Camera with OSD Function

In addition to operation by serial communication explained earlier, you can operate the camera with OSD menu on a monitor screen by connecting an optional remote controller (RU-100).

11.1. How to Operate OSD Menu by Remote Controller

[CENTER] To indicate OSD top menu on your monitor screen when OSD menu does not appear.

Also, use this button to choose the selected menu.

[▲] Move up.

[▼] Move down.

[◀] Change options.

[▶] Change options.

11.2. Indication of OSD Menu

Menu with ▼ at the line end indicates that there are submenus to open with CENTER button.

Menu with ▶ at the line head indicates that CENTER button can execute command for the chosen item.

11.3. The List of OSD Menu

Top Menu	Setting Menu	Selected Items	Description
EXIT	None	None	Push Center button to finish OSD menu.
Output Format	Set Video Format	1080p 60fps (Level A)	This is to set video format. Select video format with ◀/▶ button and push CENTER button to confirm.
		1080p 59.94fps (Level A)	
		1080p 50fps (Level A)	
		1080p 60fps (Level B)	
		1080p 59.94fps (Level B)	
		1080p 50fps (Level B)	
		1080i 60fps	
		1080i 59.94fps	
		1080i 50fps	
		1080p 30fps	
		1080p 29.97fps	
		1080p 25fps	
		1080p 24fps	
		1080p 23.97fps	
		720p 60fps	
		720p 59.94fps	
720p 50fps			

Top Menu	Setting Menu	Selected Items	Description	
Gain/Shutter/IRIS	Gain Mode	Manual/Auto	This is to set Gain Mode.	
	Gain Value	0~48dB	This is to set Gain Value when Gain Mode is Manual. (*1)/(*2)	
	Gain Max Value	0~48dB	This is to set Max Gain Value when Gain Mode is Auto. (*1)/(*2)	
	Shutter Mode	Manual/Auto	This is to set Shutter Mode.	
	Shutter Value		1/25	This is to set Shutter Value when Shutter Mode is Manual. Shutter slower than 1/60s will be limited depending on frame rate setting (*1)/(*2)/(*3)
			1/30	
			1/36	
			1/42	
			1/50	
			1/60	
			1/75	
			1/90	
			1/100	
			1/105	
			1/120	
			1/125	
			1/150	
			1/180	
			1/210	
			1/250	
			1/300	
			1/350	
			1/420	
			1/500	
			1/600	
			1/700	
			1/840	
			1/1000	
1/1200				
1/1400				
1/1700				
1/2000				
1/2400				
1/2800				
1/3400				
1/4000				
1/4800				
1/5600				
1/6800				
1/8000				
1/9600				

		1/11200		
		1/13600		
Gain/Shutter/IRIS	Shutter Min Limit	Same as Shutter Value	This is to set Min Shutter Limit when Shutter Mode is Auto. (*1)/(*2)	
	Shutter Max Limit	Same as Shutter Value	This is to set Max Shutter Limit when Shutter Mode is Auto. (*1)/(*2)	
	Set Shutter Limit	None	Push CENTER button to confirm shutter limit. When Max < Min is set, the setting will not be reflected.	
	Iris Mode	OPEN		Set it to Open when DC Iris is not in use. (*5)
		AUTO		
	Iris Response Speed	0: Low		This is to set the speed of DC Iris response when DC Iris Mode is Auto. The higher the value, the slower the DC Iris response speed becomes.
		1: Mid		
		2: High		
	AE Speed	0~15		This is to set AE convergence speed.
	ExpCompValue	-18~0~18[dB]		This is to set exposure compensation value.
	Metering Mode	Average		This is to set metering mode. Average : Averaging metering Center Weighted : Center-weighted metering Spot : Spot metering Backlight Comp: Backlight Compensation
		Center Weighted		
		Spot		
		Backlight Comp		
Spot Block X	0~15		This is to select X coordinate value of the left edge Block in the metering area when Metering Mode is "Spot".	
Spot Block Y	0~15		This is to select Y coordinate value of the top Block in the metering area when Metering Mode is "Spot".	
Spot Block W	1~16		This is to select width (Block number) of the metering area when Metering Mode is "Spot".	
Spot Block H	1~16		This is to select height (Block number) of the metering area when Metering Mode is "Spot".	
Set Spot Block	None		Push CENTER button to confirm Spot Block X, Y, W, and H.	
Flicker Cancel	ON/OFF		This is to set flicker cancel. (*4)	

(*1) If you prefer setting further detail, please set them via serial commands.

(*2) The values set via serial commands will be reflected to key operation.

(*3) There may be differences between the set shutter value and the actual shutter value. Please refer to [Section 10.4.3 Actual Shutter Value Limited by Video Output Format](#) for the actual shutter value.

(*4) Flicker cancel is invalid when the frame rate is either 50fps, 25fps, 24fps, or 23.97fps regardless of the camera settings.

(*5) When shoot a high luminance object with DC iris function, hunting may occur under some conditions. In such cases, adjust Iris Response Speed or ExpCompValue.

Top Menu	Setting Menu	Selected Items	Description
White Balance	WB Mode	Auto	This is to select and set WB Mode with ◀/▶ button.
		Auto (Outdoor)	
		Daylight (Sunlight)	
		Cloudy	
		Shade	
		Tungsten (Light bulb)	
		Flw (Fluorescent light/White)	
		Fln (Fluorescent light/Daytime white)	
		Fld (Fluorescent light/Daylight color)	
		Auto (ATW)	
		One push	
		Manual	
		Preset1	
		Preset2	
	Preset3		
	Preset4		
	Preset5		
WB Red Gain	0~800	This is to set Red/Blue Gain when WB Mode is Manual.	
WB Blue Gain	0~800		
One Push Start	None	Valid only when WB mode is One Push. Push CENTER button to execute One Push WB	
Set Preset Number	1~5	This is to select the preset number with ◀ / ▶ button, and push CENTER button to save the current WB value.	

Top Menu	Setting Menu	Selected Items	Description	
Image Control	Red Balance	50~150	This is to set Red Balance. (*3)	
	Green Balance	50~150	This is to set Green Balance. (*3)	
	Blue Balance	50~150	This is to set Blue Balance. (*3)	
	Master Pedestal	-100~100	This is to set Master Pedestal.	
	Red Pedestal	-100~100	This is to set Red Pedestal.	
	Green Pedestal	-100~100	This is to set Green Pedestal.	
	Blue Pedestal	-100~100	This is to set Blue Pedestal.	
	Edge Level	0~7	This is to set edge enhancement level. 0 is OFF.	
	Gamma		BT.709 -2	This is to set contrast of BT.709.
			BT.709 -1	
			BT.709	
			BT.709 +1	
			BT.709 +2	
	Noise Reduction	OFF/ON	This is to set Noise Reduction. Noise reduction OFF/ON	
Color Saturation	0~200	This is to set Color Saturation.		
Color Correction		Auto	This is to set Color Correction.	
		Standard		
		Fluorescent light		
		Tungsten lamp		
Color Suppression	0~7	This is to set Color Suppression.		
LTC	LTC	ON/OFF	LTC ON/OFF	
	Set LTC Reset	None	This is to reset LTC with CENTER button.	
GenLock	V Phase Offset	-1024~1023	This is to set V phase of GenLock.	
	H Phase Offset	-2048~2047	This is to set H phase of GenLock.	

(*3) 0~200 can be set via serial command.

(*4) Slight differences may occur to the set value by rebooting the camera, changing format, and adjusting V phase and H phase.

Top Menu	Setting Menu	Selected Items	Description
OSD Color Change	Default Set(White & Cyan)	None	This is to restore OSD color to default setting with CENTER button.
	User Setting		This is to set the color to indicate OSD menu.
	Menu Color	Black	This is to select the text color of OSD menu with ◀/▶ button.
		Blue	
		Green	
		Cyan	
		Red	
		Magenta	
	Yellow		
	White		
	Highlight Color	Same as Menu Color	This is to set the selected letter's font color of OSD menu with ◀/▶ button.
	Set Color	None	This is to confirm Menu Color and Highlight Color with CENTER button. If user specifies the same color for both Menu Color and Highlight Color, they will not be settled.
Flip	Horizontal Flip	OFF/ON	Horizontal flip (right and left) OFF/ON
	Vertical Flip	OFF/ON	Vertical flip (top and bottom) OFF/ON
INIT	None	None	This is to restore the camera to factory settings with CENTER button.
Save/Load	Set Save Data	0~3	This is to save data to the selected preset number with CENTER button.
	Really?	NO/YES	This is to confirm saving to the selected preset number.
	Enter	None	This is to execute SAVE or NOT SAVE and return to the original screen.
	Get Save Data	0~3	This is to load data of the selected preset number and reflect it to the image with CENTER button.

12. Factory Settings

Item	Factory Setting
Video Format Setting	1920 x 1080i @60fps
Gain Mode	Auto
Gain Value (Manual Gain)	65536(0dB)
Max Gain	2097152 (30dB)
Shutter Mode	Auto
Shutter Limit Max	17476(1/60s)
Shutter Limit Min	77(1/13600s)
Shutter Value (Manual Shutter)	17476(1/60s)
DC Iris Mode	Open
DC Iris Response Speed	Mid
Metering Mode	Center-Weight
Spot Block	X=7,Y=7, W=2, H=2
Exposure Compensation Value	18 (0dB)
AE Speed	10
Flicker Cancel	OFF
White Balance Setting	Auto
Manual Red Gain	199
Manual Blue Gain	161
Color Correction	Standard
Color Suppression	5
Color Saturation	100
Edge Enhancement	2
Noise Reduction	0
Gamma	BT.709
Master Pedestal	0
Pedestal(RGB)	0
Color Balance (RGB)	100
LTC	OFF
OSD Menu Color	White
OSD Select Color	Cyan
H Flip	OFF
V Flip	OFF
GenLock V Offset	0
GenLock H Offset	0

13. Dimensions

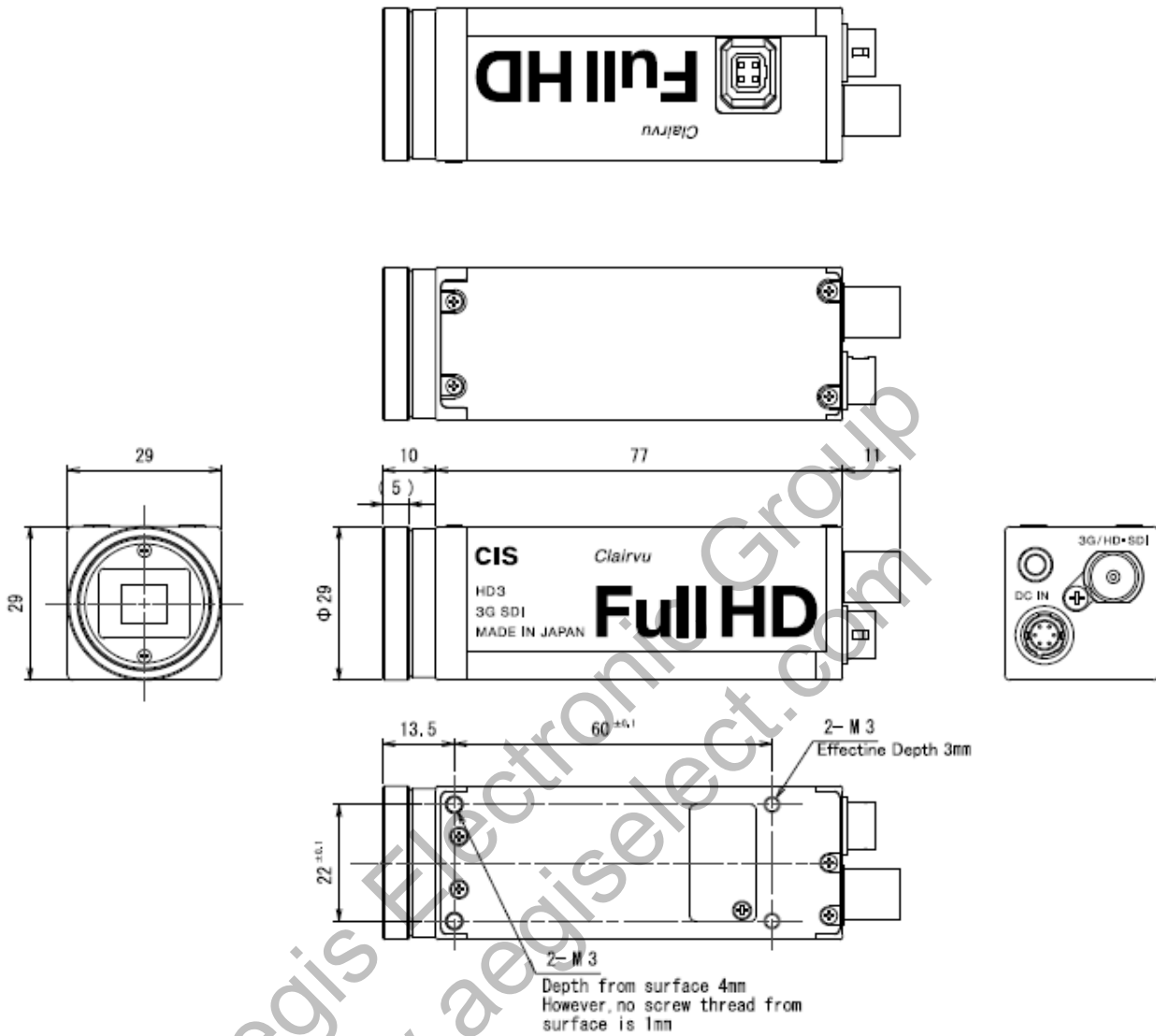

935-0065-00
(Unit: mm)

14. Case for Indemnity (Limited Warranty)

The term of warranty of this product is within 1.5 years from the date of shipping out from our factory. If you use the product properly and discover a defect during the warranty period, and if that was caused by designing or manufacturing, CIS Corporation, at its option, repairs or replaces it at no charge to you. Products out of warranty period will be subject to charge. CIS repairs the products as long as it is repairable.

CIS should not hold responsible for damages or losses if;

- damages or losses are caused by earthquake, lightning strike, fire, flood or other acts of God.
- damages or losses are caused by deliberate or accidental misuse by the user, or failure to observe the information contained in the instructions in this Product Specification and Operational Manual.
- damages or losses are caused by repair or modification conducted by the customer or any unauthorized party.

15. CMOS Defective Pixels

CIS applies defective pixel correction prior to the shipment of the product. However, the number of defective pixels are subject to increase due primarily to the effect of cosmic rays. Due to this nature, CIS should not hold responsible for the natural increase of defective pixels.

16. Product Support

Should you have any problems with the product, and if you need our further analysis and/or repair, please contact your local distributor.

- Camera Control Sample Software

Camera Control Sample Software is downloadable via our web. However, please note that CIS will be exempted from taking responsibility for any damages or malfunction that could cause to your hardware and software by using this control software.

The purpose of the control software is for you to check operation and evaluate our products. Please note that CIS does not customize the program nor provide source code.

URL: <http://www.ciscorp.co.jp/>