

VZ-3MU-M/C 56H

Industrial Digital Cameras with USB3.0 Interface



USB[®]
VISION

GEN<i>i>CAM

VZ-3MU-M/C 56H is a monochrome/color USB3.0 Vision camera with the Sony IMX265 CMOS sensor. Thanks to the extremely compact design (29mm x 29mm x 29mm), robust metal housings and locking screw connectors, the VZ-3MU-M/C 56H camera has an outstanding price and performance ratio. VZ-3MU-M/C 56H is ideal for machine vision applications such as industrial inspection, medical, scientific research, education, security and so on.

VZ-3MU-M/C 56H

Industrial Digital Camera with USB3.0 Interface

Mechanical Dimensions

Unit: mm

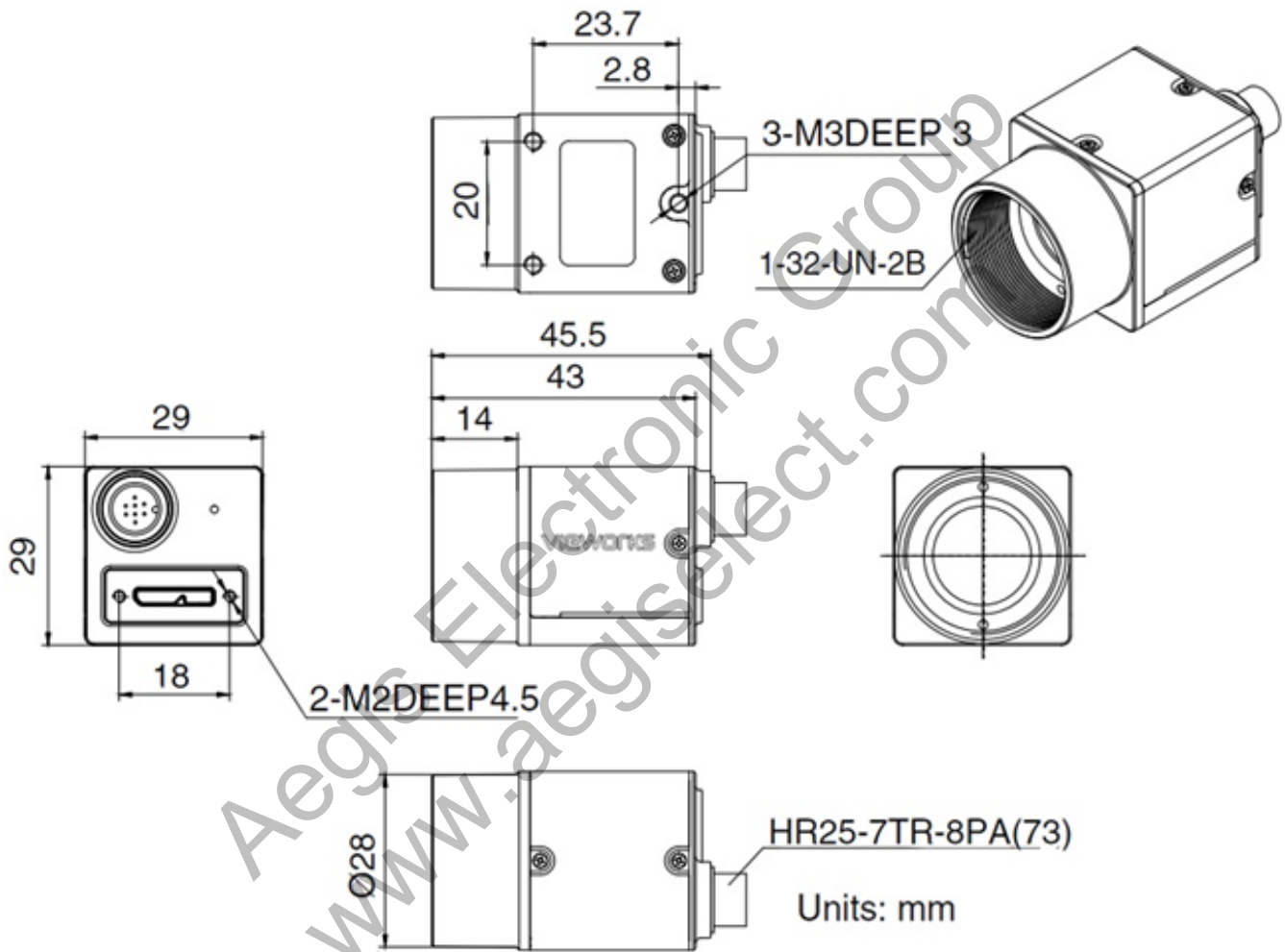

VZ-3MU-M/C 56H

Industrial Digital Camera with USB3.0 Interface

Main Features

- Trigger mode: Frame Start / Frame Burst Start
- Programmable LUTs and User Set Control
- Sequencer Control
- 16KB data storage area for saving algorithm coefficients and parameter configuration
- Multiple samples and easy-to-integrate SDKs for various programming tools
- Support Storable user sets, Timer and Counter
- Support Remove Parameter Limit to expand the range of exposure, gain, white balance, etc.
- Compatible with GenICam™ and USB3 Vision®

Applications

- Industrial Inspection
- Medical Research
- Scientific Research
- Education
- Security

Specifications

Model	VZ-3MU-M/C 56H00	
Resolution (H x V)	2048 x 1536	
Sensor	Sony IMX265 Global Shutter CMOS	
Pixel Size	3.45 μm x 3.45 μm	
Data Interface	USB 3.0	
Frame Rate	56fps@2048 x 1536	
ADC Bit Depth	12 bit	
Pixel Bit Depth	8 bit, 10 bit	
Exposure Time	UltraShort: 1 μs ~100 μs , Actual Steps: 1 μs Standard: 20 μs ~ 1 s, Actual Steps: 1 row period	
Gain	0dB ~ 24dB, Default: 0dB, Steps: 0.1dB	
Mono / Color	Color	Mono
Pixel Formats	Bayer RG8, Bayer RG10	Mono8, Mono10
Single Noise Ratio	40.09dB	40.76dB
Synchronization	Hardware trigger, Software trigger	
I/O	1 input and 1 output with opto-isolated, 2 programmable GPIOs	
Temperature	Operating: 0°C ~ 45°C, Storage: -20°C ~ 70°C	
Operating Humidity	10% ~ 80%	
Power Requirements	5 VDC via USB cable	
Power Consumption	< 2.7W@5V	
Lens Mount	C	
Dimensions and Weight	29mm x 29mm x 29mm (without lens adapter or connectors), 65g	
Programmable Control	Image size, Gain, Exposure time, Trigger polarity, Flash polarity	
Conformity	CE, RoHS, FCC, USB3 Vision, GenICam, KC	

VZ-3MU-M/C 56H

Industrial Digital Camera with USB3.0 Interface

Spectral Response

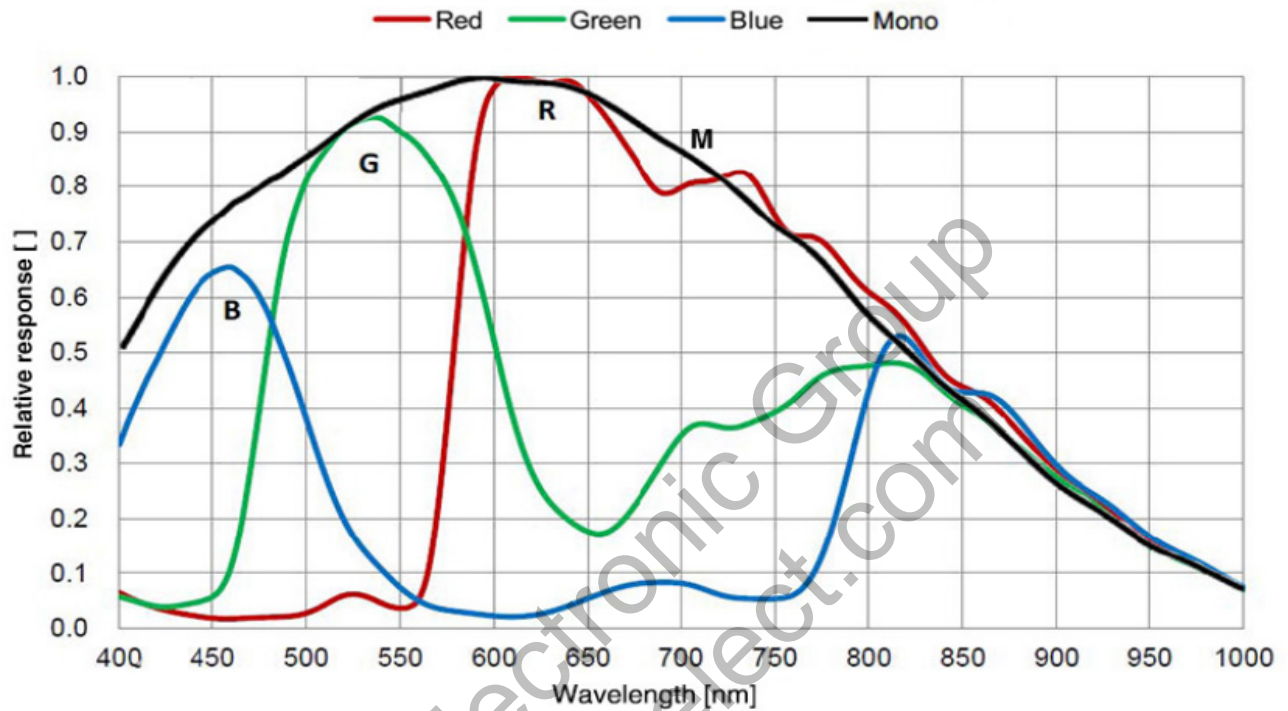

Ordering Scheme

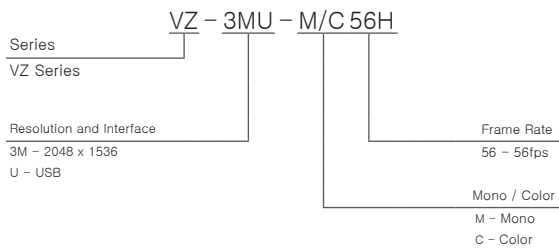

Connector Specification

Power/Control



- 1: Line0+ Opto-isolated input+
- 2: Ground GPIO GND
- 3: Line0- Opto-isolated input-
- 4: NC
- 5: Line2 GPO input/output
- 6: Line3 GPO input/output
- 7: Line1- Opto-isolated input-
- 8: Line1+ Opto-isolated input+

Connectors on camera body