

# VZ-5MG-M/C 23C

Industrial Digital Cameras with GigE Interface



VZ-5MG-M/C23C, the new industrial GigE vision camera with improved built-in ISP algorithms provides multiple acquisition controls. Thanks to the extremely compact design (29mm x 29mm x 40.3mm), robust metal housings and locking screw connectors, the VZ-5MG-M/C23C camera can secure the reliability of cameras deployed in harsh environments.

VZ-5MG-M/C23C has opto-isolated I/Os, and the GPIOs give the camera maximum flexibility to adapt to specific needs. The VZ-5MG-M/C23C camera is ideal for machine vision applications such as industrial inspection, medical, scientific research, education, security and so on.

# VZ-5MG-M/C 23C

Industrial Digital Camera with GigE Interface

## Mechanical Dimensions

Unit: mm

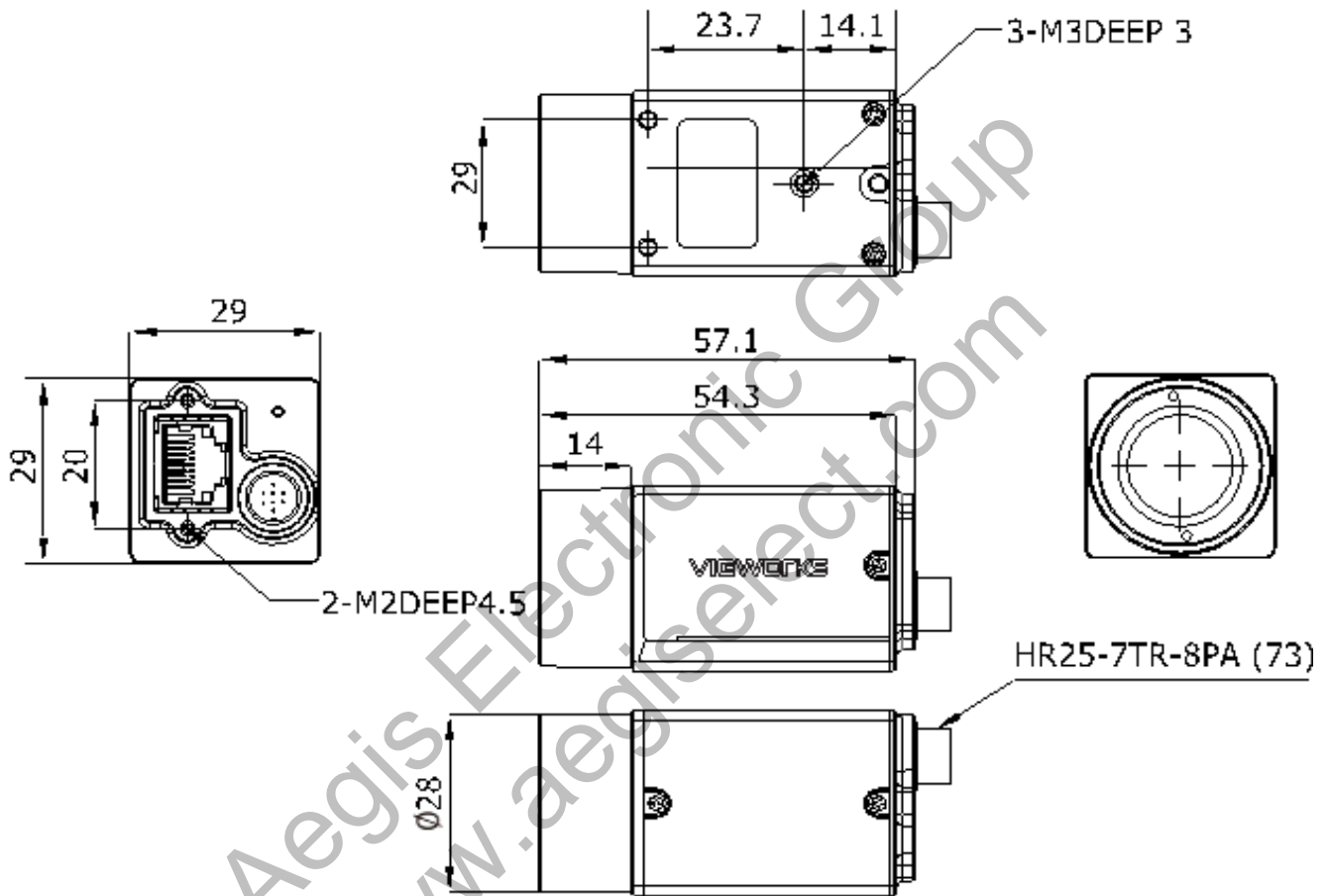

# VZ-5MG-M/C 23C

Industrial Digital Camera with GigE Interface

## Main Features

- Power over Ethernet (IEEE802.3af)
- Programmable ROI, increased frame rate with partial scan
- Programmable LUTs and storable user sets
- 4 acquisition controls: single frame, continuous, software trigger, external trigger
- Adjustable Gamma and Sharpness for optimizing the brightness and sharpness of images
- Support Remove Parameter Limit to expand the range of exposure, gain, white balance, etc.
- Compatible with GenICam™ and GigE Vision

## Applications

- Industrial Inspection
- Medical Research
- Scientific Research
- Education
- Security

## Specifications

Model	VZ-5MG-M/C 23C00	
Resolution (H x V)	2448 x 2048	
Sensor	2/3" Sony IMX264 Global Shutter CMOS	
Pixel Size	3.45 $\mu\text{m}$ x 3.45 $\mu\text{m}$	
Data Interface	Fast Ethernet (100 Mbit/s) or Gigabit Ethernet (1000 Mbit/s)	
Frame Rate	23.5 fps @ 2448 x 2048 (Adjust the packet size to 8192 and reserved bandwidth to 5)	
ADC Bit Depth	12 bit	
Pixel Bit Depth	8 bit, 12 bit	
Exposure Time	UltraShort: 1 $\mu\text{s}$ ~ 100 $\mu\text{s}$ , Actual Steps: 1 $\mu\text{s}$ Standard: 20 $\mu\text{s}$ ~ 1 s, Actual Steps: 1 row period	
Gain	0dB ~ 24dB	
Mono / Color	Color	Mono
Pixel Formats	Bayer RG8, Bayer RG12	Mono8, Mono12
Single Noise Ratio	40.69dB	40.79dB
Synchronization	Hardware trigger, Software trigger	
I/O	1 input and 1 output with opto-isolated, 2 programmable GPIOs	
Temperature	Operating: 0°C ~ 45°C, Storage: -20°C ~ 70°C	
Operating Humidity	10% ~ 80%	
Power Requirements	PoE (Power over Ethernet, IEEE802.3af compliant) or 12 VDC-10% ~ 24 VDC+10% supplied via the camera's Hirose connector	
Power Consumption	< 3 W @ 24 VDC, < 3.75 W @ PoE	
Lens Mount	C	
Dimensions and Weight	29mm x 29mm x 40.3mm, 85g	
Programmable Control	Image size, Gain, Exposure time, Trigger polarity, Flash polarity	
Conformity	CE, RoHS, FCC, GigE Vision, GenICam, KC	

# VZ-5MG-M/C 23C

Industrial Digital Camera with GigE Interface

## Spectral Response

- VZ-5MG-M23C00 (Mono)

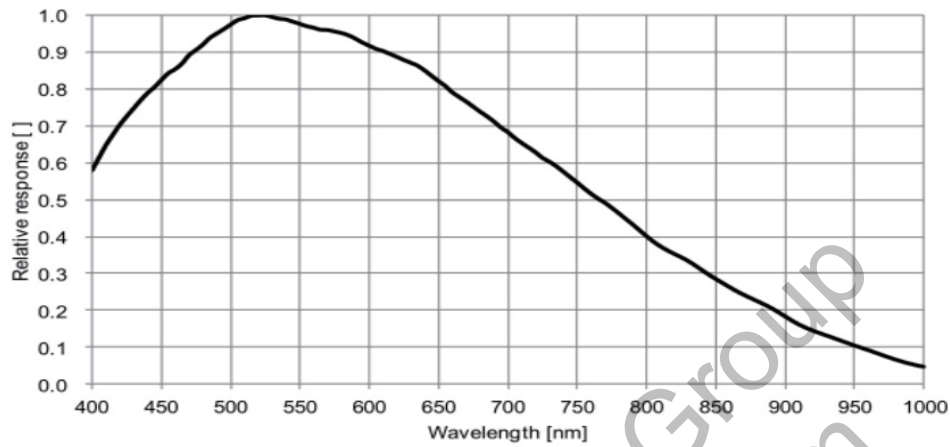

- VZ-5MG-C23C00 (Color)

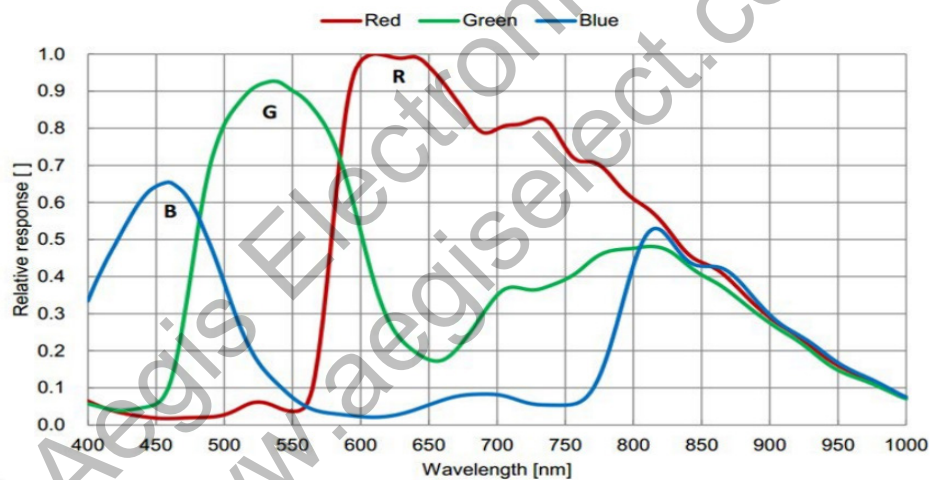

## Ordering Scheme

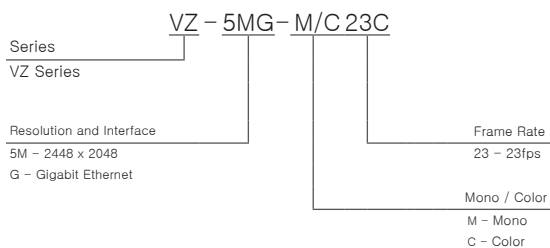

## Connector Specification

Power/Control



- |             |   |
|-------------|---|
| 1: Line0+   | Opto-isolated input+                      |
| 2: Ground   | GND & GPIO GND                            |
| 3: Line0-   | Opto-isolated input-                      |
| 4: POWER_IN | Camera external power (+12 VDC ~ +24 VDC) |
| 5: Line2    | GPO input/output                          |
| 6: Line3    | GPO input/output                          |
| 7: Line1-   | Opto-isolated input-                      |
| 8: Line1+   | Opto-isolated input+                      |

Connectors on camera body