



VZ-7IPTM

TOUCH SCREEN / WiFi IP LED TEST MONITOR



VZ-7IPTM ADVANTAGES

- 7" IPS with 1280 x 800 Resolution
- **Wifi** Connection & **Touch Screen**
- **H.265, H.264** and **4K** Support
- Hybrid - 5MP **TVI**, 4MP **CVI**, 4MP **AHD** & **HD-SDI/EX-SDI** Test
- Support **Analog (CVBS) Video Test** with NTSC/PAL, CVBS Loop Test
- **Onvif**, IP (DHCP, manual IP Setup), IPC, IPC Viewer, Rapid Video, RTSP, IP Discovery, RJ45 TDR Test
- Support Ethernet 10/100/1000 Connection and Packet Loss Test
- Video Streaming Record, Playback & Screen Shot (built-in 8GB Micro SD)
- Color Bar Generator
- **P.o.E. Test - PD & PSE**
- Provides the Ability to Troubleshoot Camera Viewing angle, Focus, Zoom, and Display Setting on Installation Site
- Support RS485 (Pelco **PTZ Control**)
- Portability, PoE and DC12V 2A Power Out
- High Capacity Power with Lithium Battery (10 hours)
- Built to run 24/7/365

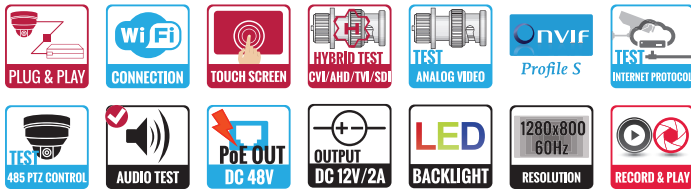

MODEL #		VZ-7IPTM
DISPLAY		
Screen Size	7"	
Max. Resolution	1280 x 800 @60 Hz pixel	
Display Color	16.7 Million	
INTERFACE		
HD/EX-SDI	1	
AHD/TVI/CVI/CVBS In	1	
CVBS Out	1	
HDMI In / Out	1 / 1	
RS485 (PTZ Control)	1	
Micro SD In	1	
Audio In / Out	1 / 1	
Ethernet 10/100/1000 with P.o.E. In / Out	1 / 1	
UTP	1	
DC 5V (2A) Out - USB Type	1	
DC 12V (2A) In / Out	1 / 2	
WEIGHT & DIMENSIONS		
Product Outline Dimension (W x H x D)	9.09" x 6.77" x 2.05"	
	230.866 mm x 171.95 mm x 52.07 mm	
Net Weight	1.95 lbs (884 g)	
GENERAL		
Battery	- Capacity	7.4V 5400mAh
	- Type	Replaceable Lithium Polymer Battery
	- Operation Time	10 Hours
P.o.E. Injector	48V/15W Output	
Power Supply	DC 12V, 2A	
	Full Charging Time - 5 to 6 Hours	
Power Saving Mode	Working, Standby & Shutdown	
Automatic Standby	Adjustable Time Interval - 5 to 30 Minutes	
Operating Temperature	14 ~ 114°F / -10 ~ 45°C	
Storage Temperature	-4 ~ 158°F / -20 ~ 70°C	
Operating Humidity	30% ~ 90%	
Warranty	- Parts / Labor	2 Year / 2 Year
Regulation	CE, FCC	
Language	English, Korean, Russian, Italian, French, Polish, Spanish, Japanese	
Package Include	VZ-70ISM x 1, US 12v DC Charger x 1, Carrying Strap x 3, BNC to BNC Cable x 1, Audio Tester Lead x 1, RJ45 Cable Tester x 1, RS485 Cable Test Lead x 1, Carrying Bag x 1, 12V Power Output Cable x1, User Manual x 1	

INTERFACE

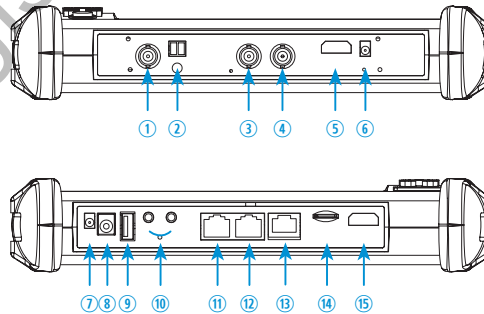

- | | | |
|---------------------------|--------------------|--------------|
| 1. HD/EX-SDI IN | 8. DC 12V IN | 15. HDMI OUT |
| 2. RS485 PTZ | 9. USB(DC 5V) OUT | |
| 3. AV(CVBS) OUT | 10. AUDIO IN / OUT | |
| 4. AV(CVBS/AHD/TVI/CIV IN | 11. LAN/PoE | |
| 5. HDMI IN | 12. PoE PSE IN | |
| 6. DC 12V OUT | 13. UTP | |
| 7. DC 12V OUT | 14. Micro SD IN | |

VZ-7IPTM

TOUCH SCREEN / WiFi IP LED TEST MONITOR

DIMENSION

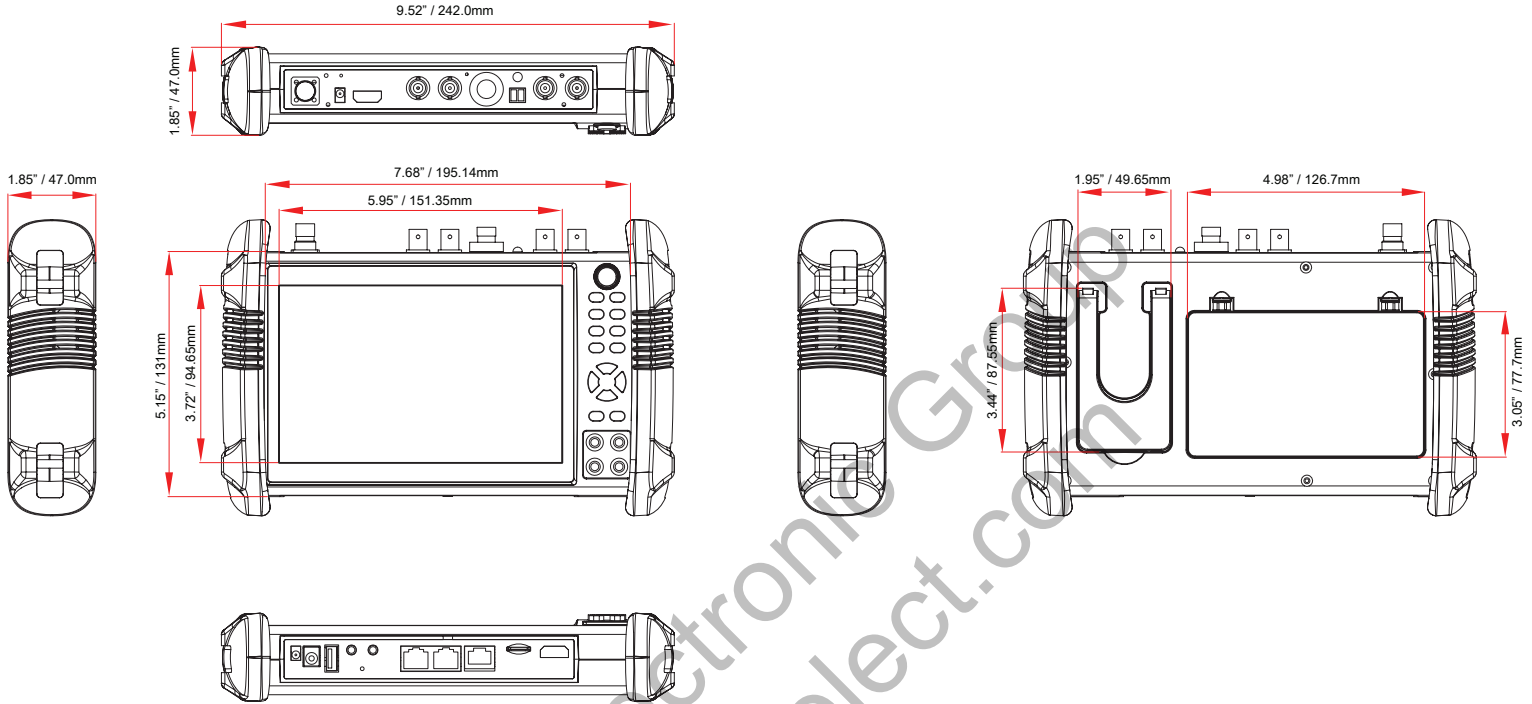

AVAILABLE TEST MODES

IPC TEST	
Ethernet test	IPC test / IPC viewer / Rapid video / RTSP / ONVIF
ONVIF camera Test	Support 2592*1520, Network PTZ controller (ONVIF)
Rapid Video	Auto view the video, create testing report
IP& CVBS Test	At the same time ,converter test from analog to digital with dual test window name, password and IP parameters
Traffic monitoring	Traffic monitoring of the tester "LAN port", display network port or WIFI connection real-time upload and download speeds and other network parameters
COAXIAL HD TEST	
TVI	5MP TVI camera test, 2560x1944p 12.5FPS, UTC control/ call OSD menu
CVI	4MP CVI camera test, 2560x1440p 25F/30F, UTC control d call OSD menu
AHD	4MP AHD test, 2560x1440P 15F/25F/30F, UTC control d call OSDmenu
HD SDI/EX-SDI	HD SDI/EX-SDI camera test, support 1080P 50/60 FPS
CVBS	1 channel BNC input & 1 channel BNC looped output, NTSC/PAL (Auto adapt)
CVBS loop test	The tester send and receive color bar generator signal, check BNC cable

PoE TEST	
PD/PSE test	Measurement POE switch or PSE power supply voltage and cable connection status
PTZ CONTROL TEST	
Communication interface	RS485
Communication protocol	PELCO-D/P, Samsung, Panasonic and over 30 Protocols
Baud rate	600-115200bps
AUDIO TEST	
Audio Test	1 channel audio signal input, test whether sound normal, 1 channel audio signal, to connect headphone