

Network

KNC-FMST947-iB

QHD 5.14MP High Resolution
IP Camera



features

- 1/2.8" Progressive Scan STARVIS CMOS
- 2592x1944@30(25)fps
- H.264 High Profiles
- Fixed lens 3.6mm
- Electronic Day&Night
- 3D DNR, DSS, BLC, DWDR, Defog
- PoE / 12VDC

1/2.8"

30/25fps
QHD

CMOS

1944 p

MOTION



DNR



DSS



VIDEO

Rolling
Shutter

Specifications

Image Sensor	1/2.8" Progressive Scan STARVIS CMOS	
Effective Pixels	2616(H) x 1964(V)	
Scanning	Progressive scan	
Video Output	Network	
	Analog	NIL
Lens	Type	Fixed lens
	Focal Length	3.6mm, F2.0
Board Lens	Angle of View	-
	2.8mm	-
	3.6mm	112.2°(D) x 67.5°(H) x 52.5°(V)
	6.0mm	-
	8.0mm	-
4.3mm	-	
White Balance	Automatic, Outdoor, Cloudy sky, Light bulb, Flames, Manual	
Dynamic Range	Method	DOL-HDR
	Level(dB)	171dB (Estimated)
Electronic Shutter Speed	1/25(30)~1/100,000	
Auto Gain Control(AGC)	Max.50dB	
Day&Night	Automatic/Day/Night (Electronic D&N)	
Digital Slow Shutter(DSS)	Off~30	
Noise Reduction	2D, 3D DNR	
Motion Detection	4 Zones	
Privacy Masking Zone	8 Zones	
Image Rotation	Off/Flip/Mirror	
Lens Distortion Correction (LDC)	On/Off	
Image Stabilization (DIS)	NIL	
Defog	Off/On(Level:1~3)	
Alarm	Alarm In/Out	NIL
	Alarm Triggers	Motion, AI, Tamper, System, Manual, Network, Timer, Day/Night
	Alarm Events	E-Mail, FTP, Video Boost, Image(AE), Notification Server

Ethernet	10/100 Base-T LAN	
Video Compression Format	H.264 (High,Main,Base) Profile, MJPEG	
Video Resolution	2592x1944, 2560x1920, 2048x1536, 1920x1440, 1600x1200, 1280x960, 800x600, 640x480, 480x360, 388x216	
Max. Frame Rate	First: 2592x1944 30(25)fps (H.264, MJPEG) Second : 1280x960 30(25)fps (H.264, MJPEG) Third : 640x480 30(25)fps (H.264, MJPEG)	
Streaming Capability	Simultaneously H.264 and MJPEG (Multi Streaming)	
Streaming Method	Unicast, Multicast	
Bitrate Control	H.264:CBR, VBR	
Max. User Access	10 clients	
Audio	Audio In/Out	1CH Audio in
	Compression Format	G.711
IP	Communication	2way
	IP	IPv4,IPv6
Protocol	TCP/IP, UDP, IPv4/v6, HTTP, HTTPS, FTP, UPnP, RTP, RTSP, RTCP, DHCP, ARP, Zeroconf, Bonjour	
Security	-	
Web Viewer	Web Browser	Internet Explorer
	Language	English, 한국어, Tiếng Việt Nam, 日本語, 中文
External Storage	NIL	
SW Integration API	API, Onvif (Profile S/T Compliant)	
Ingress Protection Grade	NIL	
Color/Material	Black / Aluminum	
Dimension(mm)	47.5mmX47.5mm	
Weight	Approx. 112g (with PoE DC12V) / Approx. 98.6g (with DC12V Cable)	
Operating Temperature	-10°C~+50°C, Humidity(Less than 90%)	
Storage Temperature	-20°C~+60°C, Humidity(Less than 90%)	
Vandal Resistance	NIL	
Supply Voltage	12VDC(±10%), PoE(IEEE802.3af)	
Power Consumption	12VDC(Max.300mA), PoE(Max.5.0w)	

Dimension

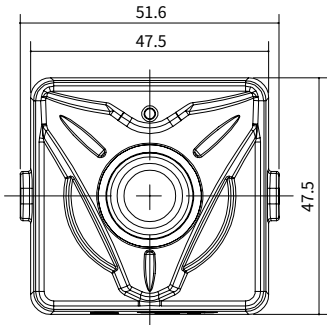

Top

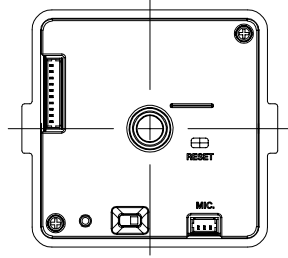

Bottom

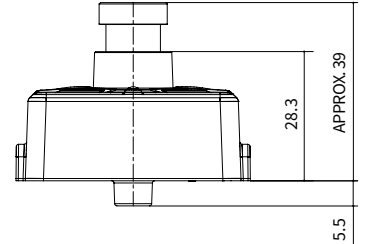

Side

Aegis Electronic Group
www.aegiselect.com