CIS

CoaXPress I/F

5M CMOS

Color (RAW) Camera

VCC-5CXP7R

Product Specifications & Operational Manual

(Preliminary)

CIS Corporation

Table of Contents

1.	Handling Precautions	1
1.1.	Camera Handling Precautions	1
1.2.	Restrictions on Applications	1
1.3.	Disclaimers (Exception Clause).....	1
2.	Product Outline	2
2.1.	Features.....	2
2.2.	Accessories	2
3.	Specifications.....	3
3.1.	General Specifications	3
3.2.	Input and Output Specifications	5
3.2.1	TRIGGER_IN Input (6pins connector No.5 pin)	5
3.2.2	SIGNAL_OUT Output (6pins connector No.3pin).....	5
3.3.	External Connector Pin Assignment	6
3.3.1	6pins Circular Connector	6
3.3.2	75Ω BNC Connector	6
3.3.3	LED Indicator.....	6
3.4.	Spectral Response	7
3.5.	Output Timing	8
3.5.1	Horizontal Sync. Timing	8
3.5.2	Vertical Sync. Timing	9
4.	Camera Functions	10
4.1.	Camera Interface.....	10
4.2.	How to Save and Initialize Settings	10
4.3.	Link Speed and Link Count	11
4.4.	Pixel Format	11
4.5.	Flip.....	12
4.6.	Internal Sync. Mode (Free Run Mode)	13
4.7.	External Trigger Sync. Mode.....	14
4.8.	Trigger Sync Mode and Delay Time to Start Exposure	16
4.9.	Delay Time to Read Out (Read Out Delay).....	16
4.10.	Restrictions on Timing of Trigger Pulse Input	17
4.11.	Fixed Trigger Shutter Mode (LineSync) H Sync Trigger	17
4.12.	FAST Fixed Trigger Shutter Mode (CbckSync) CLK Sync Trigger	18
4.13.	Pulse Width Trigger Shutter Mode (LineSync) H Sync Trigger.....	19
4.14.	FAST Pulse Trigger Shutter Mode (CLK Sync) CLK Sync Trigger	20
4.15.	Exposure Time.....	21
4.16.	Calculation Formula for Manual Shutter with H Sync Mode.....	22
4.17.	Manual Shutter Setting with CLK Sync Mode (FAST Trigger Mode)	22
4.18.	Gain	22
4.19.	Gamma Correction.....	22
4.20.	Sensor Black Level Adjustment.....	23
4.21.	Partial Scan (ROI)	23
4.22.	White Balance	26
4.23.	Image Quality Selection Mode.....	27
4.24.	Shading Correction	27
4.25.	Impulse Noise Filter	28

4.26.	Defective Pixel Correction.....	28
4.27.	Test Pattern Indication	32
4.28.	Cursor Indication.....	32
4.29.	LED Operational Mode.....	32
4.30.	Camera Timing Output	33
4.31.	User ID.....	33
4.32.	Temperature Indication	33
5.	Factory Settings	34
6.	Dimensions	35
6.1.	Camera Dimensions	35
6.2.	Optical Axis Accuracy	36
7.	Case for Indemnity (Limited Warranty).....	37
7.1.	Product Warranty	37
7.2.	CMOS Defective Pixels.....	37
7.3.	Product Support.....	37

PRELIMINARY

1. Handling Precautions

1.1. Camera Handling Precautions

- Do not use or store camera in dusty or humid places.
- Do not apply excessive force, vibration, or static electricity that could damage camera. Please handle camera with care.
- Do not shoot direct images that are extremely bright (e.g., strong light source, sun, etc.). When extremely strong light source is shot, smear or blooming may occur. Put the lens cap on when camera is not in use.
- Follow the instructions in [Chapter 3.3, "External Connector"](#) for connecting camera. Improper connection may cause damages not only to the camera but also to the connected devices.
- Confirm mutual ground potential carefully before connecting camera to monitors or computers. Any AC leak from the connected devices may cause damages or destroy the camera.
- Do not apply excessive voltage. (Use only the specified voltage.) Unstable or improper power supply voltage may cause damages or malfunction of the camera.
- VCC-5CXP7R is a highly dense camera in a small foot print. CIS recommends you to install the camera on a metal plate to avoid heat.
- Our warranty does not apply to damages or defects caused by irregular and/or abnormal use of the product.

Our warranty does not apply to damages or defects caused by neglecting the instructions and precautions explained in this manual.

1.2. Restrictions on Applications

- The camera must not be used for any nuclear equipment or aerospace equipment with which mechanical failure or malfunction could result in serious bodily injury or loss of human life.
- The camera must not be used under conditions or environments other than those specified in this manual.

1.3. Disclaimers (Exception Clause)

CIS should not be liable for any damages or losses if;

- damages or losses are caused by earthquake, lightning strike, fire, flood, or other acts of God.
- damages or losses are caused by deliberate or accidental misuse by user, or failure to observe information and instructions explained in this manual.
- damages or losses are caused by repair or modification conducted by user or any unauthorized party.

2. Product Outline

VCC-5CXP7R is a small color (RAW) camera with CoaxPress interface.

Using 1/1.8", global shutter type 5M pixels CMOS image sensor, frame rate reaches 101fps with CXP6 8bit. Complies with CoaxPress Version 1.1.1 and transfers data up to 100m with CXP-3 and approx. 40m with CXP-6.

Must have function ready for Machine Vision applications such as trigger shutter, ROI, Gain, shading correction, and defective pixels correction. Suitable for various Machine Vision inspection systems and others.

2.1. Features

- Global shutter type, CMOS sensor
- Complies with CoaxPress Ver. 1.1.1 and supports CXP-3 and CXP6.
- Supports 1 lane
- Maximum cable length: 30m
- ROI function
- Exposure setting, Gain setting
- External trigger mode (Fixed trigger shutter mode/Pulse width trigger shutter mode)
- Complies with GenICam
- C lens mount
- Small foot print, 29x29x55mm

2.2. Accessories

- Standard accessory
 - Lens cap (TBD)

3. Specifications

3.1. General Specifications

Electrical Specifications			
Image sensor	Sensor type	1/1.8", Global shutter type CMOS sensor	
	Effective pixels	2472 (H) × 2064 (V)	
	Unit cell size	2.74μm (H) × 2.74μm (V)	
Interface		Complies with CoaXPress Ver. 1.1.1. Supports CXP6_x1, and CXP3_x1	
Pixel Clock Frequency		74.25MHz	
Video output format		BayerRG8 / BayerRG10 / BayerRG12 BayerGR8 / BayerGR10 / BayerGR12 (Horizontal flip) BayerGB8 / BayerGB10 / BayerGB12 (Vertical flip) BayerBG8 / BayerBG10 / BayerBG12 (Horizontal and Vertical Flip)	
Frame rate	CXP3 8bit/10bit/12bit	50fps / 40fps / 34fps	
	CXP6 8bit/10bit/12bit	101fps / 82fps / 68fps	
Sync. system		Internal sync.	
Resolution (maximum resolution)		2472 (H) × 2064 (V)	
Video signals (Gain 0dB)	White clip level	255	with 8bit
	Set up level	0~2	with 8bit
	Dark shading	Under 4 for both vertical and horizontal	with 8bit
Sensitivity		F11 2000lx (Shutter speed 1/30s, Gain 0dB, 8 bit) F5.6 2000lx (Shutter speed 1/30s, Gain 0dB, 10/12 bit)	
Minimum illumination		F1.4, 3.6lx (Shutter speed 1/30s, Gain +18dB, level=50%, 8 bit) F1.4, 16lx (Shutter speed 1/30s, Gain +18dB, level=50%, 10/12 bit)	
Gain variable range		x1 ~ x64 (0dB ~ +36dB) [guarantee range]	
Shutter speed		Manual	
Gamma correction		Valid ($\gamma=0.10\sim1.80$)	
Trigger mode		Free run mode (Camera internal trigger) Trigger mode (Host, External terminal) <ul style="list-style-type: none"> • Fixed trigger shutter • Pulse width trigger shutter 	
Partial scan		8 areas with Horizontal and Vertical	
Flip	Horizontal		
	Vertical		
Power requirements		PoCXP: 18.5 ~ 26V	
Power consumption		3.3W typ. (CXP-3), 3.9W (CXP-6) [with free run]	

Mechanical Specifications	
Dimensions	H: 29mm W: 29mm D: 55mm excluding projection.
Weight	Approx. 70g
Lens mount	C mount

Environmental Specifications			
Safety/Quality standard			
CE EMC: 2014/30/EU Emission: EN61000-6-4:2007+A1:2011 Immunity: EN61000-6-2:2019 RoHS: 2011/65/EU (EU)2015/863 Complies with EN50581 (RoHS2) KC Standard			
Durability	Vibration	Acceleration	: 98m/s ² (10G)
		Frequency	: 20 ~ 200Hz
		Direction	: X, Y, and Z 3 directions
		Testing time	: 120min for each direction
	Shock	No malfunction with 980m/s ² (100)G for ±X, ±Y, and ±Z 6 directions without packaging.	
Operational temperature		0 ~ +45°C Humidity: 20 ~ 80%RH with no condensation.	
Storage temperature		-25 ~ +60°C Humidity: 20 ~ 80%RH with no condensation.	

3.2. Input and Output Specifications

3.2.1 TRIGGER_IN Input (6pins connector No.5 pin)

- 5.0V, 3.3V CMOS level / TTL level
- Input voltage Low: 0.5Vdc (Max.), High: 2.1Vdc (Min.)
- This is to directly input a trigger from an external equipment. To use this terminal, set Trigger Source of AcquisitionControl to Line0.

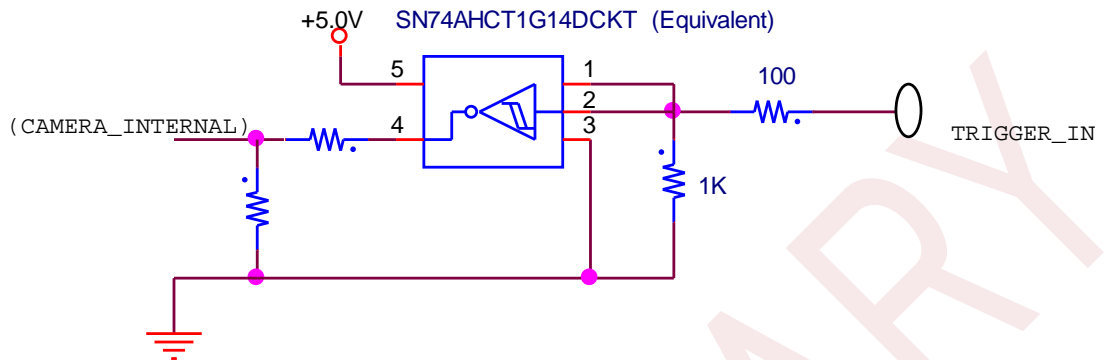

3.2.2 SIGNAL_OUT Output (6pins connector No.3pin)

- 5.0V CMOS logic level output
- Output voltage Low: 0.35Vdc (Max.), High: 4.5Vdc (Min.)
- This is to output a timing signal of the camera. Set a signal with Line Source of Digital IO Control.

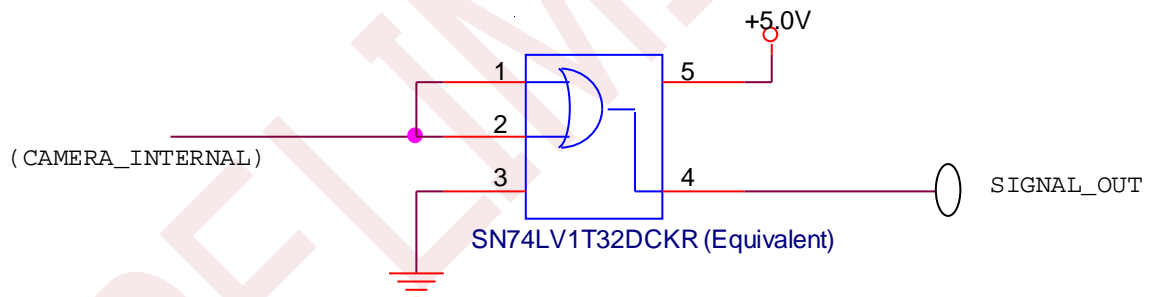

3.3. External Connector Pin Assignment

3.3.1 6pins Circular Connector

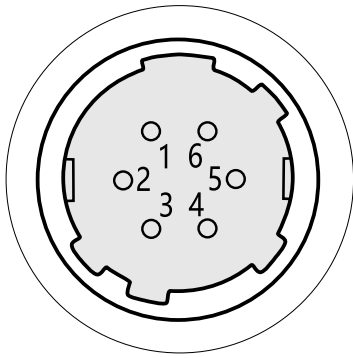

HR10-7R-6PA
(HIROSE or equivalent)

Pin No.	Signals	Note
1	NC	
2	NC	
3	SIGNAL_OUT	Exposure / FVAL / LVAL / Link Trigger
4	NC	
5	TRIGGER_IN	Trigger input
6	GND	Ground camera chassis

※NC=Non-Connection. Do not connect anything to the terminal.

3.3.2 75Ω BNC Connector

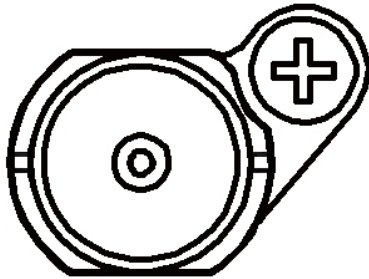

(BCJ-BPLHA: CANARE)

3.3.3 LED Indicator

With LED indicator ON, lighting patterns show the camera status by its way of lighting.

OFF	No Power supply.
Green Lighting	Completion of connection between device and host.
Green Fast Blinking [12.5Hz]	Transmitting video data.
Orange Slow Blinking [1Hz]	Waiting for a trigger input.
Red Fast Blinking [12.5Hz]	System error / Trigger error

3.4. Spectral Response

※ Excludes characteristics of lens, IR cut filter, and light source.

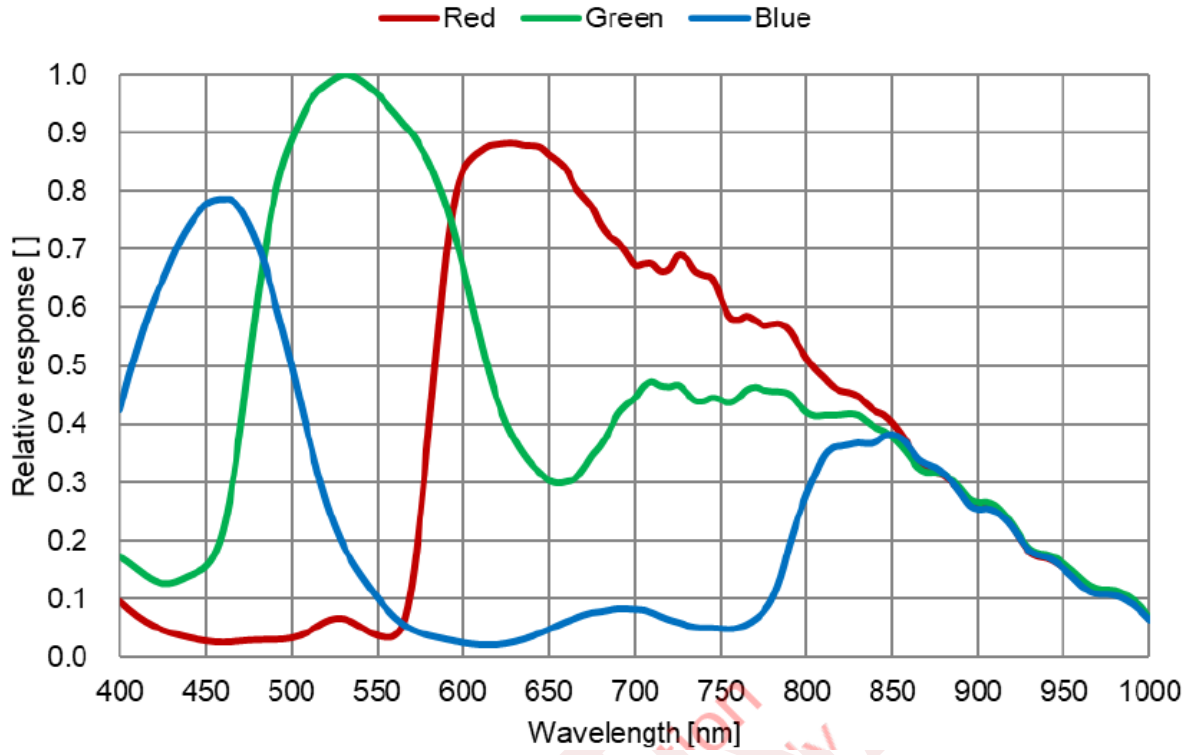

PRELIMINARY

3.5. Output Timing

3.5.1 Horizontal Sync. Timing

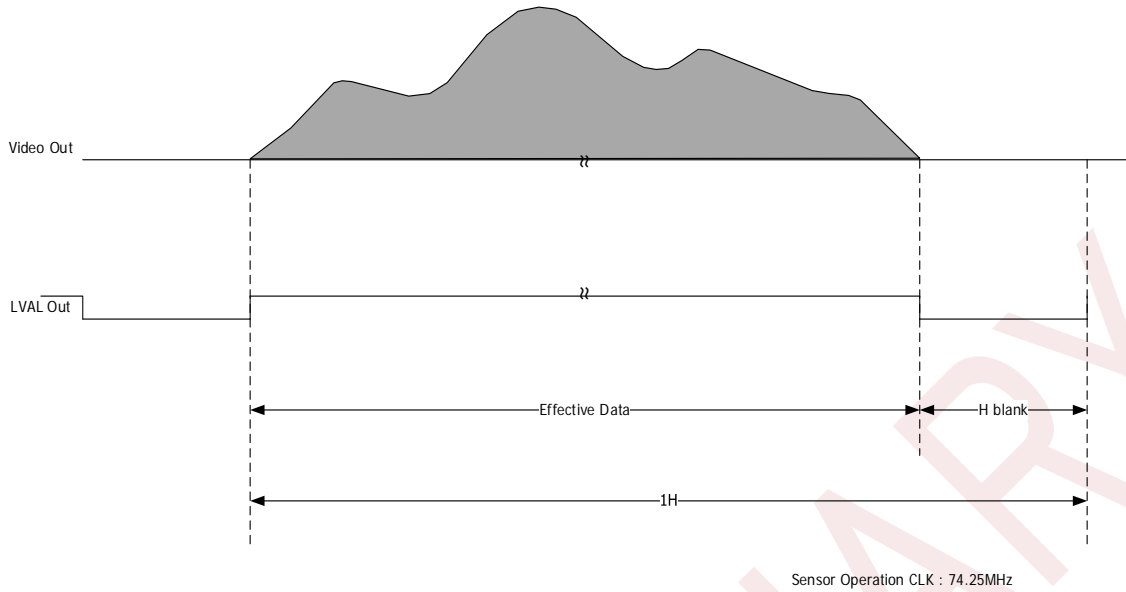

※Time for 1H varies according to video output format.

※The number of blanking pixels with 1H varies according to video output format.

Chart 3.5.1.1- Number of effective pixels and number of blanking pixels (with full frame)

Link rate	Video output format	Effective Data / 8ch	H Blank / 8ch	Total pixel number for 1H / 8ch	Time for 1H [us]
CXP-3	BayerRG/GR/GB/BG 8	309	343	652	8.781
	BayerRG/GR/GB/BG 10	309	506	815	10.976
	BayerRG/GR/GB/BG 12	309	669	978	13.172
CXP-6	BayerRG/GR/GB/BG 8	309	17	326	4.391
	BayerRG/GR/GB/BG 10	309	98	407	5.481
	BayerRG/GR/GB/BG 12	309	180	489	6.586

Sensor Operation CLK = 74.25MHz

3.5.2 Vertical Sync. Timing

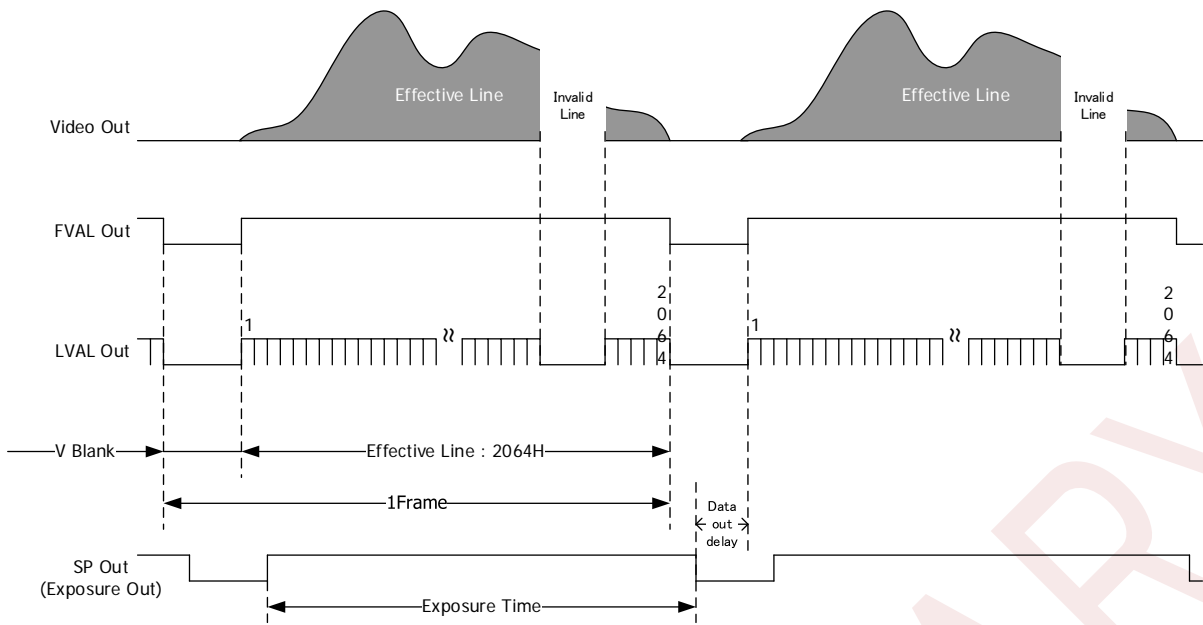

※Time for frame varies according to video output format.

※For data out delay, refer to Section 4.9 Delay Time to Read Out (Read Out Delay).

Chart 3.5.2.1- Number of effective pixels and number of blanking pixels (with full frame)

Link rate	Video output format	Effective Line	Invalid Line	V Blank	Total line number for 1 Frame	Time for 1H [ms]
CXP-3	BayerRG/GR/GB/BG 8	2064	24	148	2236	19.635
	BayerRG/GR/GB/BG 10	2064	20	140	2224	24.412
	BayerRG/GR/GB/BG 12	2064	16	128	2208	29.083
CXP-6	BayerRG/GR/GB/BG 8	2064	24	148	2236	9.817
	BayerRG/GR/GB/BG 10	2064	20	140	2224	12.191
	BayerRG/GR/GB/BG 12	2064	16	128	2208	14.542

Sensor Operation CLK = 74.25MHz

4. Camera Functions

4.1. Camera Interface

- Complies with CoaXPress1.1.1 standard.

4.2. How to Save and Initialize Settings

- This is a function to save camera settings in operation into nonvolatile memory and to load setting values saved in the nonvolatile memory.
- There are two types of setting values.
 - User setting values: Setting values that user can arbitrary save and read out.
 - Factory setting: Initial setting values upon shipment from factory.

UserSets	
UserSetSelector	Default UserSet0
UserSetLoad	(Execute)
UserSetSave	(Execute)

- UserSetSelector: This is to save the current setting values or to select setting values saved in nonvolatile memory to read out.
 - Default: Factory setting upon shipment from factory.
 - UserSet0: User settings.

※ Default (Factory setting) is not subject to save.
 ※ Values of UserSetSelector are not subject to save with UserSetSave. The values always become Default.
 Please set values before executing UserSetLoad or UserSetSave.
- UserSetLoad: This is to load setting values selected with UserSetSelector.
- UserSetSave: This is to save the current setting values to the area selected with UserSetSelector.

Note)

- Do not execute UserSetLoad while grabbing (acquiring images).
- Shading correction values, defective pixel correction values, DeviceUserID, and DeviceUserString are not subject to UserSetLoad for Default. (Camera keeps those values)
- ConnectionConfig, PixelFormat, ImageQualityMode, Reverse X, and Reverse Y are not subject to UserSetLoad so that camera keeps values in operation. If you wish to change those values, set values with each command.

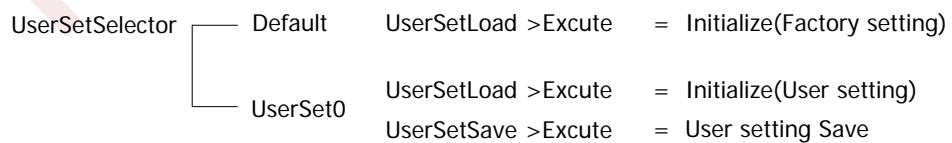

4.3. Link Speed and Link Count

Transfer Control	
ConnectionConfig	CXP3_X1 CXP6_X1

- ConnectionConfig: Selection of Link speed and Link count
CXP3_X1: Link speed=3.125Gbps, Link count=1
CXP6_X1: Link speed=6.250Gbps, Link count=1

※ Do not change ConnectionConfig while grabbing (acquiring images).

4.4. Pixel Format

ImageFormatControl	
PixelFormat	BayerRG8 BayerRG10 BayerRG12 BayerGR8(ReverseX = On) BayerGR10(ReverseX = On) BayerGR12(ReverseX = On) BayerGB8(ReverseY = On) BayerGB10(ReverseY = On) BayerGB12(ReverseY = On) BayerBG8(ReverseX= On, ReverseY = On) BayerBG10(ReverseX= On, ReverseY = On) BayerBG12(ReverseX= On, ReverseY = On)

- PixelFormat: Selection of Pixel format
BayerRG8: Bayer 8 bit
BayerRG10: Bayer 10 bit
BayerRG12: Bayer 12 bit
BayerGR8: Bayer 8 bit (ReverseX = On)
BayerGR10: Bayer 10 bit (ReverseX = On)
BayerGR12: Bayer 12 bit (ReverseX = On)
BayerGB8: Bayer 8 bit (ReverseY = On)
BayerGB10: Bayer 10 bit (ReverseY = On)
BayerGB12: Bayer 12 bit (ReverseY = On)
BayerBG8: Bayer 8 bit (ReverseX= On, ReverseY = On)
BayerBG10: Bayer 10 bit (ReverseX= On, ReverseY = On)
BayerBG12: Bayer 12 bit (ReverseX= On, ReverseY = On)



Bayer Pattern of VCC-5CXP7R is "RGGB" as shown in the picture left. Refer to section 4.5 Flip. When image is flipped in X and Y direction, Bayer Pattern flips. Pixel format also changes RG, GR, GB, and BG.
※ Do not change PixelFormat while grabbing (acquiring images).

4.5. Flip

- This is a function to flip images in X direction or Y direction.
- With True, function flips image with normal rotation. With False, function flips image with reversal rotation.

ImageFormatControl	
ReverseX	True/False
ReverseY	True/False

- ReverseX: Flip the image in X direction.
- ReverseY: Flip the image in Y direction.
- ※ Do not change FLIP while grabbing (acquiring images)
- ※ When image is flipped in X and Y direction, Bayer Pattern flips. Pixel format also changes RG, GR, GB, and BG.

【Note】

- With ROI, the origin coordinates (0, 0) of OffsetX/OffsetY appears on the left top corner of the display screen regardless On/Off of flipping.
- The following illustration shows coordinates according to the setting order of ReverseX/ReverseY and ROI.

• Flipping with ROI

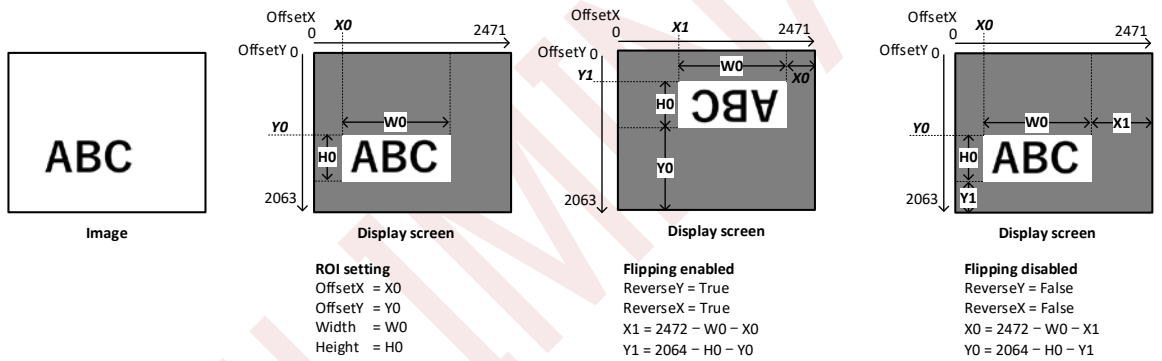

• ROI with Flipping

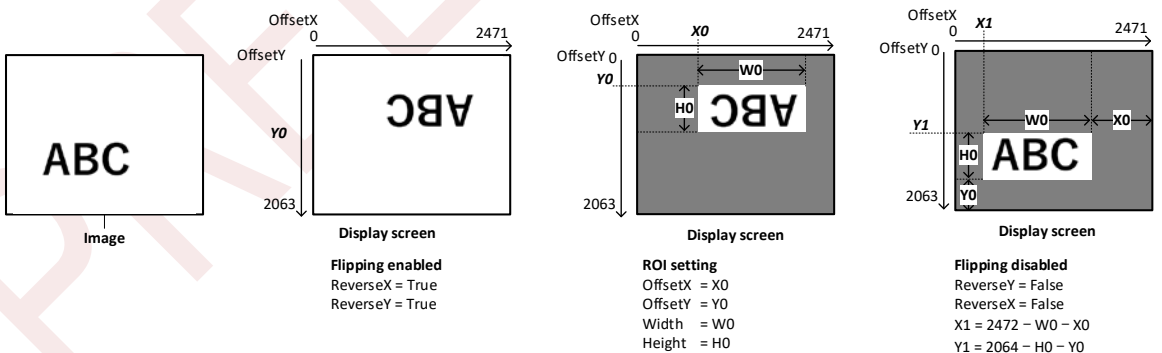

4.6. Internal Sync. Mode (Free Run Mode)

- This is a mode to use internal triggers continuously generated.
- Turn off TriggerMode and set TriggerSelector to AcquisitionStart.
- The table below shows frame rate with full frame.

Chart 4.6.1-Frame rate with full frame scan

PixelFormat	CXP6_X1	CXP3_X1
BayerRG/GR/GB/BG8	101.8	50.9
BayerRG/GR/GB/BG10	82.0	40.9
BayerRG/GR/GB/BG12	68.7	34.3

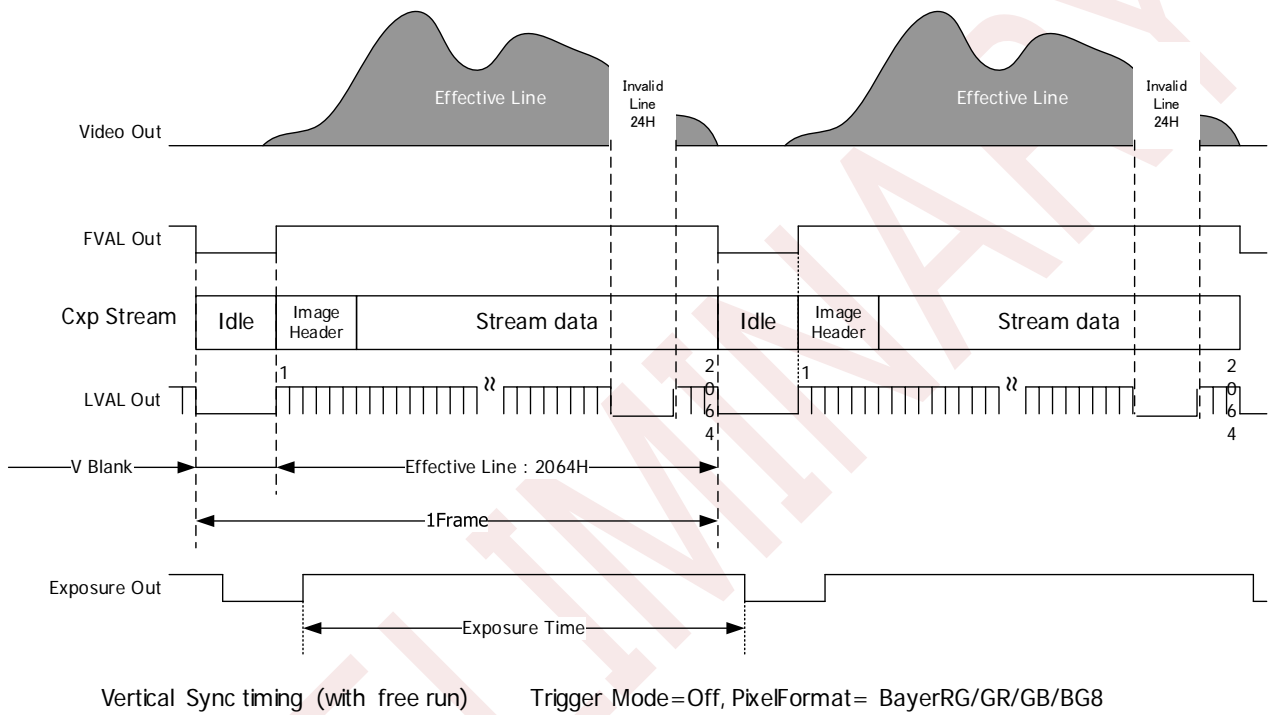

4.7. External Trigger Sync. Mode

- This is a mode to input external trigger signals to capture images by any preferred timings.
- Set TriggerSelector to FrameStart, or turn on TriggerMode, and set TriggerSource to either one of Software/LinkTrigger0/Line0.

AcquisitionControl	
TriggerMode	On/Off
TriggerSyncMode	LineSync ClockSync
TriggerSelector	AcquisitionStart FrameStart
TriggerActivation	RisingEdge FallingEdge LevelHigh LevelLow
TriggerSource	Software LinkTrigger0 Line0
TriggerSoftware	Execute
AcquisitionFrameRate	(Read Only)

- TriggerMode: TriggerMode links with TriggerSelector.
 - Off: Free run mode. (TriggerSelector = AcquisitionStart)
 - On: External trigger mode. (TriggerSelector = FrameStart)
 - ※ Do not change Trigger Mode while grabbing (acquiring images).
- TriggerSelector: TriggerSelector links with TriggerMode.
 - AcquisitionStart: Free run mode (TriggerMode = Off)
 - FrameStart: External trigger mode (TriggerMode = On)
 - ※ Do not change TriggerSelector while grabbing (acquiring images).
- TriggerSyncMode:
 - LineSync: H Sync trigger mode (Controls exposure time per line)
Fixed/Pulse width trigger shutter mode
Enables overlap operation (enables exposure while reading out video)
 - ClockSync: CLK sync trigger mode (Controls exposure per sensor clock)
FAST fixed/FAST pulse width trigger shutter mode
Disables overlap operation (disables exposure while reading out video)
 - ※ Change TriggerSyncMode when there is no trigger input.
 - ※ Set LineSync mode to change the mode to free run mode.

- TriggerSource: This is to select where to send external triggers.
 - LinkTrigger0: External trigger input from CoaXPress Host Device.
Please refer to specification manuals of the Host Device such as frame grabber board to know how to generate triggers.
 - Line0: External trigger input from 6pins circular connector.
 - Software: TriggerSoftware
- ※ Change TriggerSelector to FrameStart, or turn on TriggerMode, to set either one of TriggerSource.
 ※ Software Trigger becomes valid with Rising Edge.

- TriggerSoftware: Software trigger
Camera generates a trigger to capture one frame image by executing this command.
※ Set TriggerSource to Software.

- TriggerActivation: This is to select how to start capturing video or its polarity out of the followings.
 - RisingEdge: Fixed trigger shutter mode: Rising edge (Timed).
 - FallingEdge: Fixed trigger shutter mode: Falling edge (Timed).
 - LevelHigh: Pulse-width trigger shutter mode: High active. (TriggerWidth).
 - LevelLow: Pulse-width trigger shutter mode: Low active (TriggerWidth).
- ※ Change TriggerSelector to FrameStart, or turn on TriggerMode, to set either one of TriggerActivation.

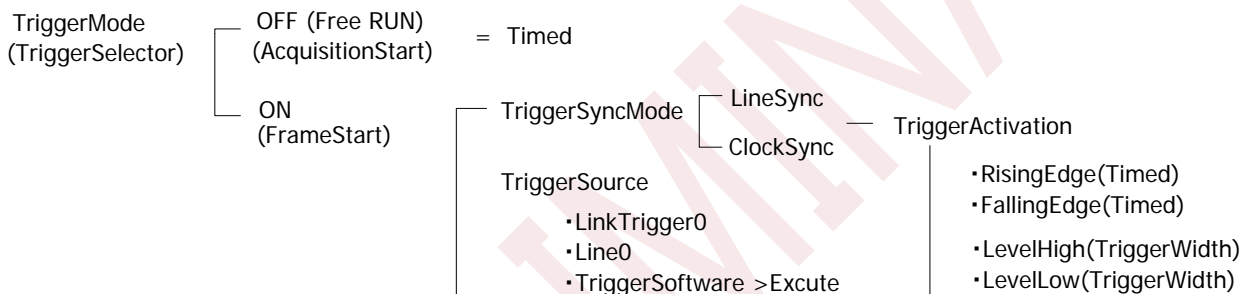

- AcquisitionFrameRate: This is to show frame rate for internal sync mode (free run mode).
 ※ Even with external trigger mode, this function shows frame rate for internal sync mode.

4.8. Trigger Sync Mode and Delay Time to Start Exposure

- H Sync Trigger Mode (LineSync): 1H jitter occurs between trigger input and exposure. (enables overlap operation).
- CLK Sync Trigger Mode (ClockSync): There are few delay from trigger input and exposure. Useful for precise trigger operation. (disables overlap operation).

Chart 4.8.1- Delay Time to Start Exposure

Mode	PixelFormat	CXP6_X1 CXP3_X1
Delay time to start exposure with H Sync Trigger (LineSync) (Full frame)	BayerRG/GR/GB/BG 8	Approx.12H~13H
	BayerRG/GR/GB/BG 10	Approx.12H~13H
	BayerRG/GR/GB/BG 12	Approx.10H~11H
Delay time to start exposure with CLK Sync Trigger (ClockSync) (Full frame)	BayerRG/GR/GB/BG 8	Approx.0.1us
	BayerRG/GR/GB/BG 10	Approx.0.1us
	BayerRG/GR/GB/BG 12	Approx.0.1us

4.9. Delay Time to Read Out (Read Out Delay)

Chart 4.9.1-Delay Time to Read Out

Mode	PixelFormat	CXP6_X1 CXP3_X1
Delay time to read out with H Sync Trigger (LineSync) (Full frame)	BayerRG/GR/GB/BG 8	77H
	BayerRG/GR/GB/BG 10	69H
	BayerRG/GR/GB/BG 12	57H
Delay time to read out with CLK Sync Trigger (ClockSync) (Full frame)	BayerRG/GR/GB/BG 8	73H
	BayerRG/GR/GB/BG 10	65H
	BayerRG/GR/GB/BG 12	53H

4.10. Restrictions on Timing of Trigger Pulse Input

- User can input a trigger for the next frame while camera is reading out signals. However, do not input a trigger pulse to end exposure while camera is reading out signals. In other words, a trigger pulse to start reading out signals for the next frame before completion of reading out signals for the current frame is restricted.

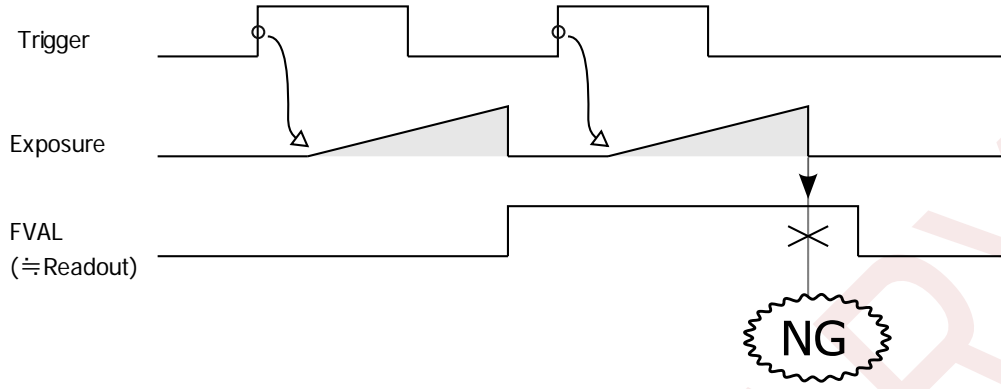

- If there is a trigger input with restricted timing explained in the above, "IllegalTriggerFlag" becomes "1".

Acquisition Control	
IllegalTriggerFlag	0 or 1

Device Control	
ErrorFlagReset	Execute

- This is to reset IllegalTriggerFlag to "0".

4.11.Fixed Trigger Shutter Mode (LineSync) H Sync Trigger

(TriggerMode=On, TriggerSyncMode=LineSync, TriggerActivation= RisingEdge)

- This is a mode to start exposure with external trigger input and expose for a period set by Exposure Time.
- Trigger operation is H Sync. V-sync. Reset.
- Delay time from detecting the trigger edge in the camera to start exposure (Exposure Time Delay) is 10H~13H with full frame scan.
- Since external trigger signals sync with camera internal H signals, 1H jitter occurs with Exposure Time Delay.
- Input more than 1H width pulse with trigger signals. Please refer to chart below for Time for 1H.
 - Full frame / ROI: Chart 3.5.1.1
- Exposure output means exposure period.

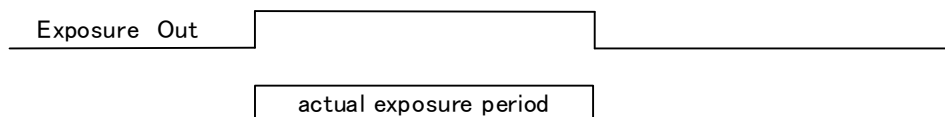

- Accepts trigger input while outputting video images. However, do not input a trigger pulse to start reading out signals for the next frame before completion of reading out signals for the current frame.
- Camera ignores trigger inputs during exposure period (Exposure Time). Refer to the chart A) below. However, trigger cycle must be more than 1 frame.

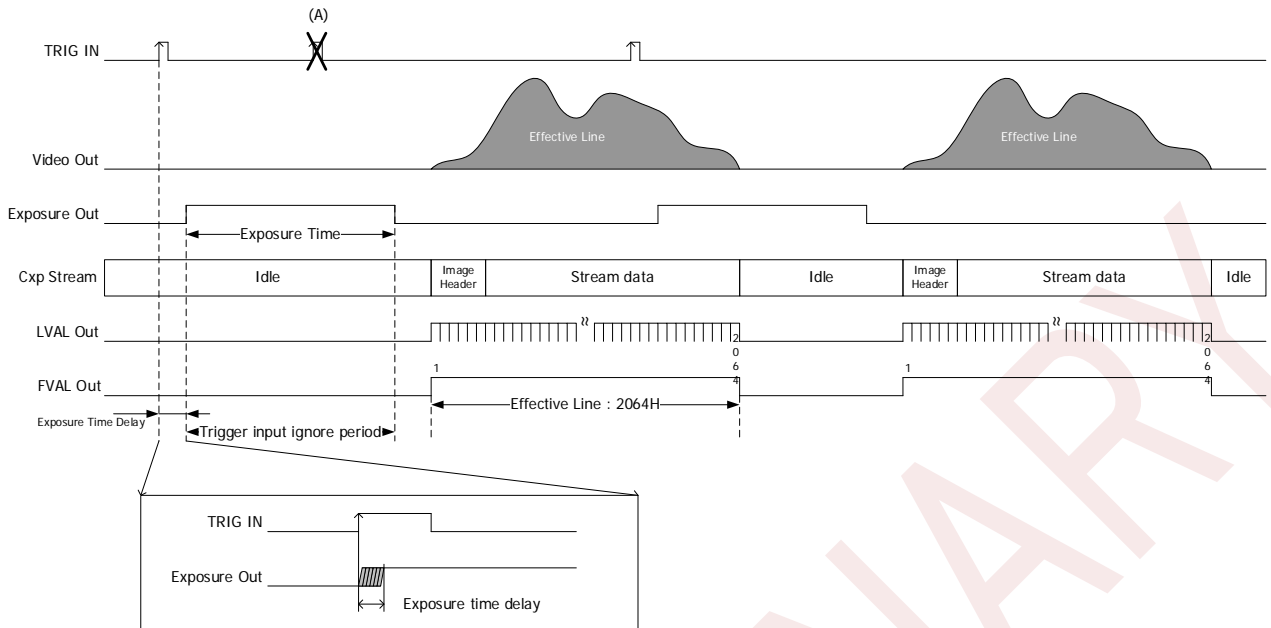

4.12. FAST Fixed Trigger Shutter Mode (ClockSync) CLK Sync Trigger

(TriggerMode=On, TriggerSyncMode=ClockSync, TriggerActivation= RisingEdge)

- This is a mode to start exposure with external trigger input and expose for a period set by Exposure Time.
- Trigger operation is CLK Sync. V-sync. Reset.
- Delay time from detecting the trigger edge in the camera to start exposure (Exposure Time Delay) is approx. 0.1 μ s.
- Input more than 1 μ s width pulse with trigger signals.
- Exposure output means exposure period.

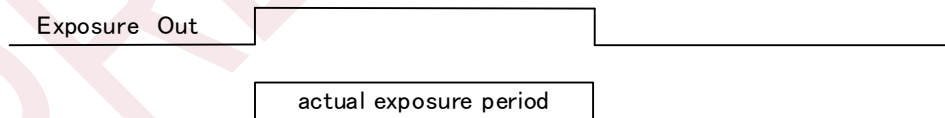

- Accepts no trigger input while outputting video images.

- Camera ignores trigger inputs during exposure period (Exposure Time) and during reading out signals. Refer to the chart A) and B) below.

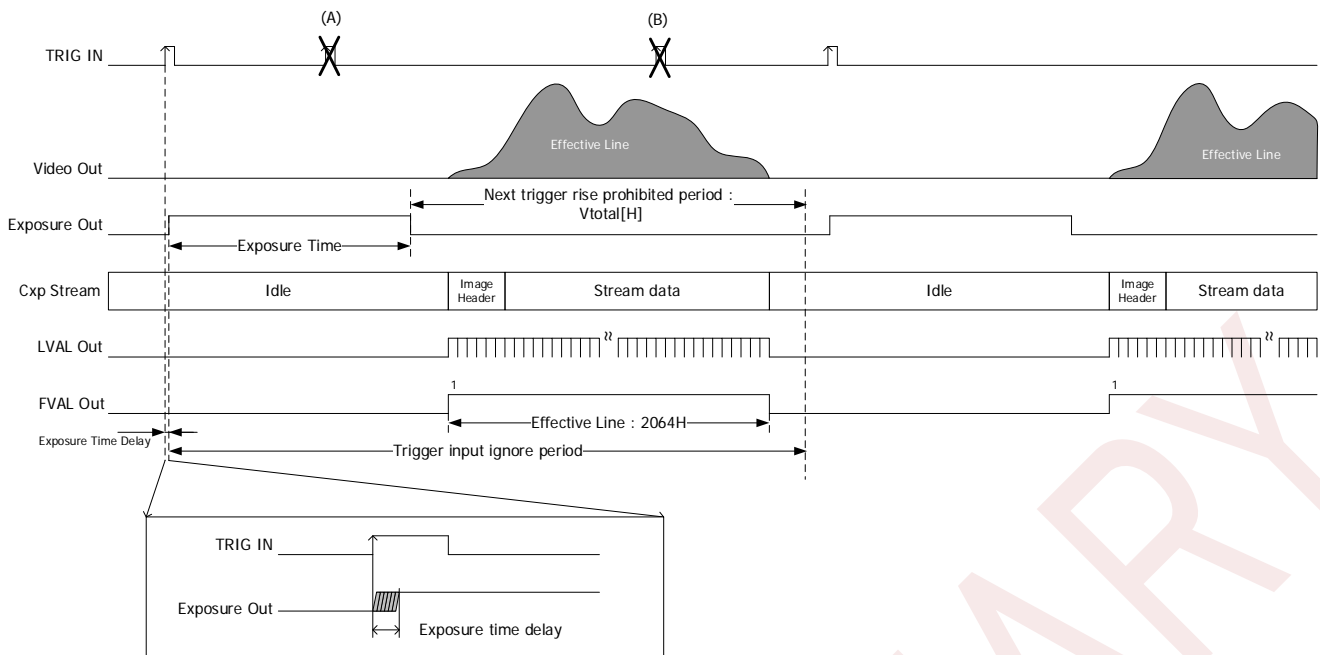

4.13. Pulse Width Trigger Shutter Mode (LineSync) H Sync Trigger

(TriggerMode=On, TriggerSyncMode=LineSync, TriggerActivation= LevelHigh)

- This is a mode to start exposure with external trigger input and expose for a period of pulse width.
- Trigger operation is H sync. V-sync. reset.
- Delay time from detecting the trigger edge in the camera to start exposure (Exposure Time Delay①):
Exposure Time Delay ① = Exposure Start Time Delay (Refer to Chart 4.8.1 for Exposure Start Time Delay)
- Delay time from detecting the trigger end edge in the camera to end exposure (Exposure Time Delay②):
Exposure Time Delay ② = Exposure Start Time Delay + 2.47μs
(Refer to Chart 4.8.1 for Exposure Start Time Delay)
- Since external trigger signals sync with camera internal H signals, 1H jitter occurs with Exposure Time Delay ① and ②. With Pulse Width Trigger mode, jitter may occur at both start and end edges. In this case, exposure time changes and flicker may be noticeable especially with high speed shutter. Fixed trigger shutter mode could improve the situation but you can solve this issue by synchronizing trigger pulse with camera H cycle (LVAL) to input.
- Pulse width is 1H (minimum) ~ approx. 2 frames. Functionally, there is no upper limitation but noises such as dark noise and shading noise may become noticeable with long timer exposure.

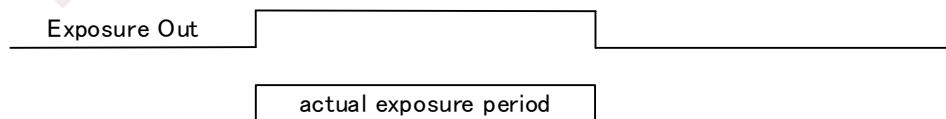

- Camera ignores trigger inputs during exposure period (Exposure Time). Input more than 1 frame cycle with trigger signals.

- Accepts trigger input while outputting video images. However, do not input a trigger pulse to start reading out signals for the next frame before completion of reading out signals for the current frame. Refer to chart A).
- Note)
- With some frame grabber boards, A)below may occur when stop grabbing.
 - With some frame grabber boards, A)below may occur while grabbing and when changing exposure time.
 - LED lights red blinking when an inappropriate trigger occurs as explained in the above.
- You can clear this with ErrorFlagReset.

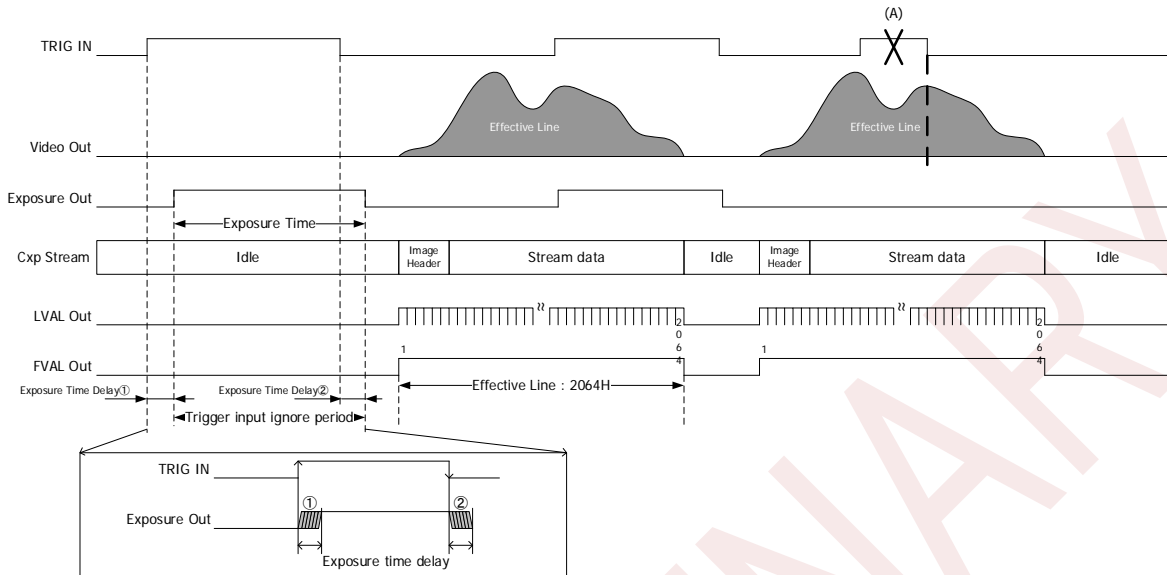

4.14. FAST Pulse Trigger Shutter Mode (CLK Sync) CLK Sync Trigger

(TriggerMode=On, TriggerSyncMode=ClockSync, TriggerActivation= LevelHigh)

- This is a mode to start exposure with external trigger input and expose for a period of pulse width.
- Trigger operation is CLK sync. V-sync. reset.
- Delay time from detecting the trigger edge in the camera to start exposure (Exposure Time Delay①) is approx. 0.1μs.
- Delay time from detecting the trigger end edge in the camera to end exposure (Exposure Time Delay②):

Chart 4.14.1-Exposure End Delay Time with ClockSync

Video output mode	Video output format	Exposure Time Delay②
Full frame scan	BayerRG/GR/GB/BG 8	8H + 2.63us
Virtual scan	BayerRG/GR/GB/BG 10	8H + 2.63us
	BayerRG/GR/GB/BG 12	6H + 2.63us

※ Time for 1H: Full frame/ROI (Chart 3.5.1.1)

2x2 Binning Ave (Chart 3.5.1.3), 1/2 Decimation (Chart 3.5.1.4)

- Pulse width is 1μs (minimum) ~ approx. 2 frames. Functionally, there is no upper limitation but noises such as dark noise and shading noise may become noticeable with long timer exposure.
- Exposure output means exposure period.

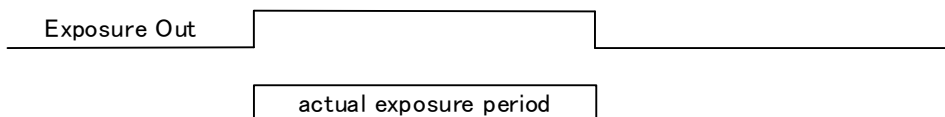

□ Camera ignores trigger inputs during reading out period. Refer to A) below.

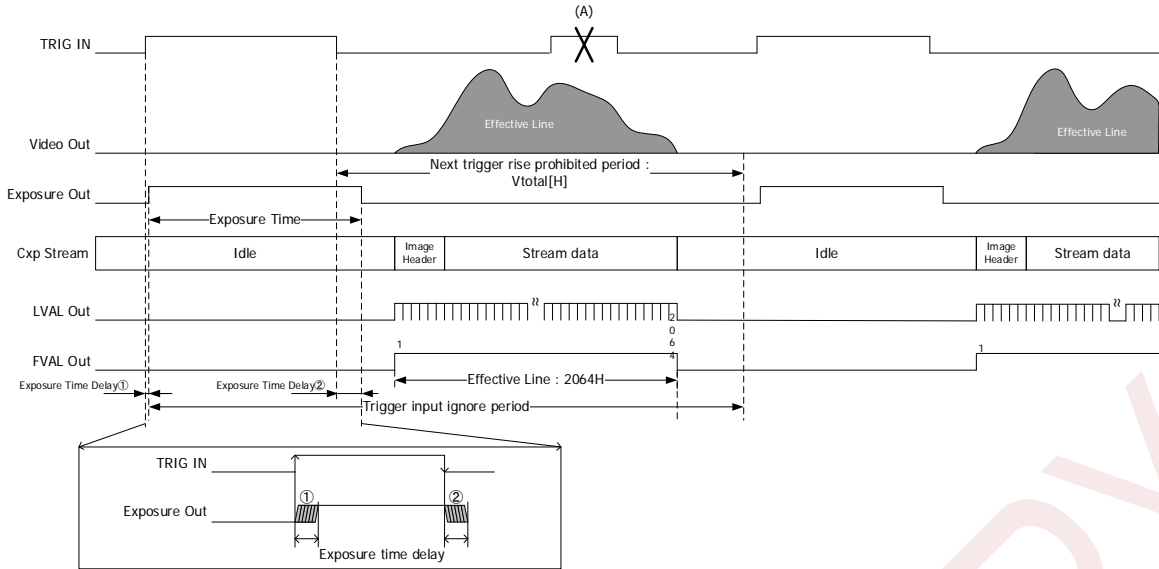

4.15. Exposure Time

AcquisitionControl	
ExposureMode	Timed Trigger Width
ExposureTime (us)	5us ~ Maximum exposure time: LineSync 91us ~ 200ms : ClockSync
ExposureTimeMax	(Read Only)

- ExposureMode: You can check if the current mode is Timed or Trigger Width (PWC).
- ExposureTime: Exposure time (Valid when ExposureMode is Timed)
 - With H sync trigger, exposure time becomes the rounded values (us) per 1H for each mode. Exposure time depends on ConnectionConfig and PixelFormat.
 - With CLK sync trigger, exposure time is set per approx. 1us.
 - Refer to calculation formula for manual shutter in Section 4.16 and 4.17.
- ExposureTimeMax: Maximum exposure time
 - With H sync trigger, the maximum exposure time depends on partial scan setting (ROI), ConnectionConfig and PixelFormat.
 - With CLK sync trigger, the maximum exposure time is 200 [ms] fix.
 - Refer to calculation formula for manual shutter in Section 4.16 and 4.17.

Note)

- With internal sync mode, set a smaller value than ExposureTimeMax.
- With H sync trigger mode (LineSync), effective line count (including with Partial setting) clips Exposure Time.
- With CLK sync trigger mode (ClockSync), you can set Exposure Time from 91us to 200ms.

4.16. Calculation Formula for Manual Shutter with H Sync Mode

- Calculation formula: Exposure Time = Time for 1 Line x Exposure Line Number + **2.47 μ s**
- ※ Time for 1H: Full Frame/ROI (Chart 3.5.1.1)
- ※ The minimum setting value is 1. The maximum setting value is clipped with 2064 or total line count with Partial setting.

4.17. Manual Shutter Setting with CLK Sync Mode (FAST Trigger Mode)

- The minimum setting value: **91 μ s** (approximate value)
- The maximum setting value: **200ms** (approximate value)
- ※ Not clipped by total line count.
- ※ Bright point may be noticeable with long exposure time.
- Setting unit: per 1 μ s (approximate value)
- ※ Slight differences occur because 74.25MHz clock generates shutter value.
- Calculation Formula: Exposure Time = Setting Value + Delay Time – 0.1 μ s
(Refer to Chart 4.14.1 for Delay Time.)

4.18. Gain

AnalogControl	
Gain	1.00~256.00

- Gain: Preferred gain settings per 0.01 from 1.00 to 256.00.
User can set gain values up to x256 but guaranteed range is up to x64.
With high gain settings, noise will increase and image quality deteriorates.

4.19. Gamma Correction

AnalogControl	
Gamma	0.10~1.80 coefficient

- Gamma : This is to set gamma correction value per 0.01 step from 0.10 to 1.80.
[Note] Camera updates gamma table at the timing of image output.
With continuous operation mode, camera applies the updated gamma table at the timing of image output after completion of rewriting gamma table (approx. 20ms: refer to Command ACK as a rough guide).
If user changes gamma coefficient while waiting for a trigger input, camera outputs images with updated gamma table with a trigger after completion of rewriting gamma table.

4.20. Sensor Black Level Adjustment

- This is to adjust black level of image sensor.

AnalogControl	
BlackOffset	-64~63

[Note]

- This is not to set the absolute black level value, but to change black level settings relatively.
- Values are 12 bit converted. With 10bit, values become equivalent to ± 16 .
With 8bit, values become equivalent to ± 4 .
- With 10-bit images, set values with 4 times of signal level. With 8-bit images, set values with 16 times of signal level.
- User can change settings while capturing but images may be disturbed.

4.21. Partial Scan (ROI)

- This is to vertically and horizontally cut and reduce read out area.
- User can set up to 8 partial areas.
- User can increase frame rate by vertically cutting and reducing read out area.

Frame rate does not change when user horizontally cut and reduce read out area.

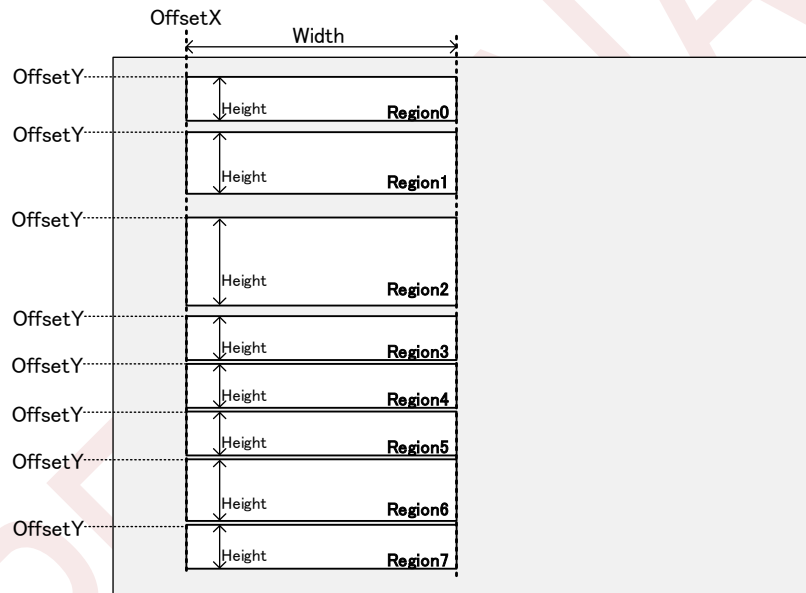

Chart 4.2.1. ROI with full frame setting

ImageFormatControl	
RegionSelector	EffectiveRegion , Region 0~7
RegionMode	On/Off
RegionDestination	Stream0 (fix)
Width	640~2472 (Multiple of 8)
Height	8~2064 (Multiple of 8)
OffsetX	0~1832 (Multiple of 8) ^[1]
OffsetY	0~2056 (Multiple of 8) ^[1]

^[1]: When number of effective region is 1, user can set multiple of 4.

- RegionSelector: This is to select Region to set.
User can set 8 partial areas with Region 0~7.
Select EffectiveRegion to output video.
By selecting EffectiveRegion, user can check Width and Height of effective partial area.
- RegionMode: On/Off of the selected Region.
Enables regions with Region 0~7.
※ Enabled only when Width, Height, OffsetX, and OffsetY are effective.
- RegionDestination: Selection of Stream to output. Fixed with Stream0.
- Width: Width of Region.
- Height: Height of Region.
- OffsetX: Offset for X direction of Region.
- OffsetY: Offset for Y direction of Region.

[Note]

- Height and OffsetY should be as follows.
When region count is 1: $4 \leq \text{OffsetY} + \text{Height} \leq 2064$
When region count is more than 2: $8 \leq \text{OffsetY} + \text{Height} \leq 2064$
※ Make sure that OffsetY and Height do not overlap with other regions.
- Width and OffsetX should be as follows.
 $640 \leq \text{OffsetX} + \text{Width} \leq 2472$
※ OffsetX of all effective regions must be the same.
※ Width of all effective regions must be the same.
- With shading correction ON, effective region must be 1.
- With impulse noise filter ON, effective region must be 1.

Setting example: 3 partial areas

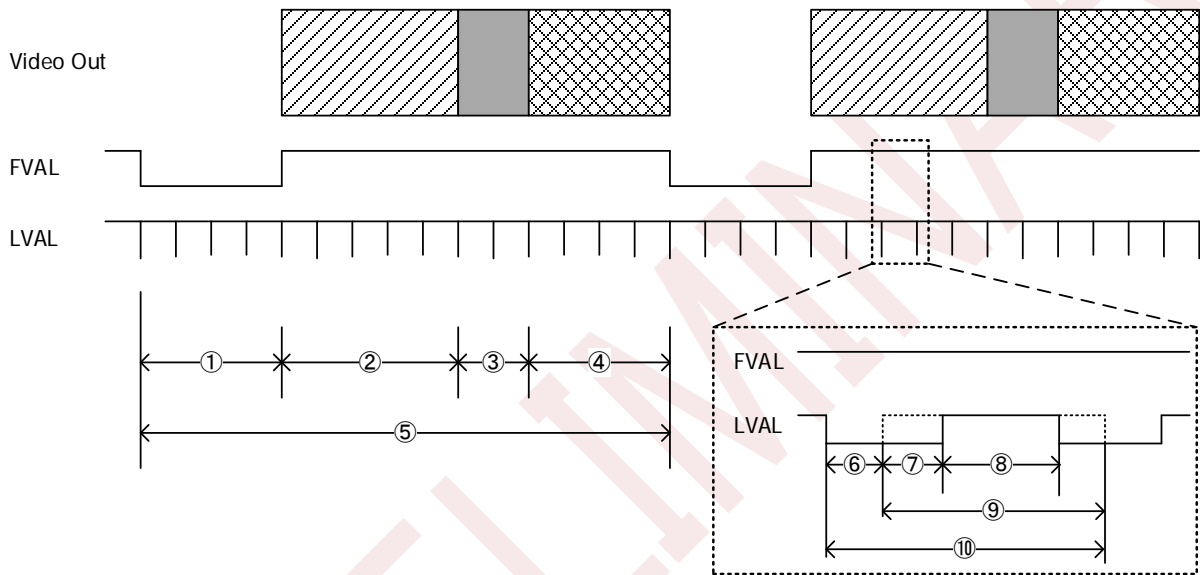
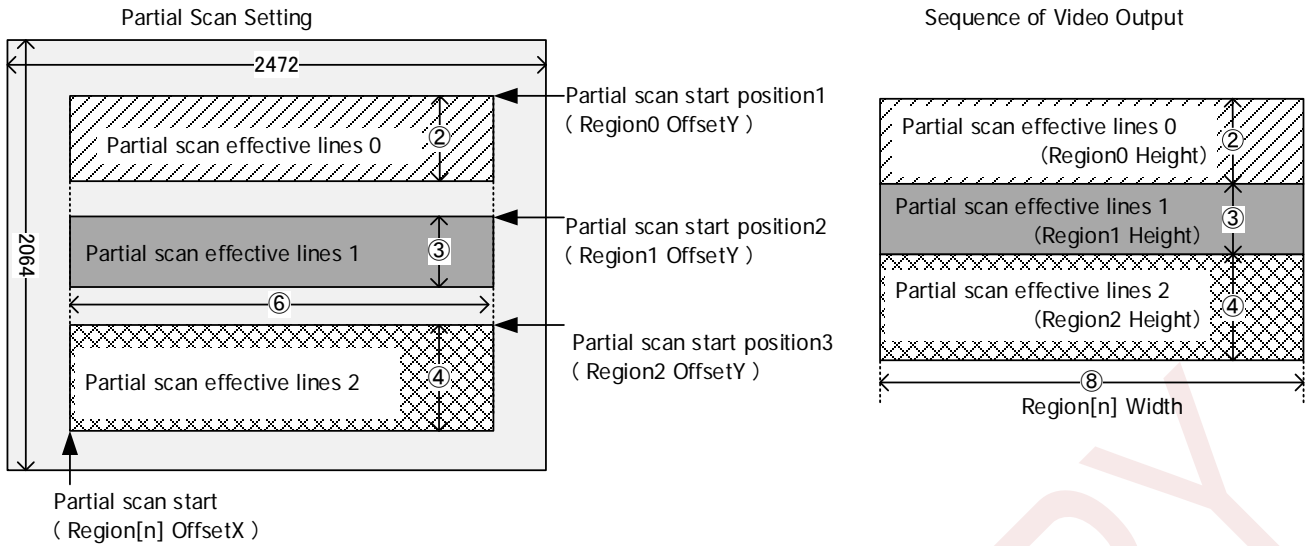

- ① : V blanking line
- ② : Partial area 0 line
- ③ : Partial area 1 line
- ④ : Partial area 2 line
- ⑤ : Entire frame line
- ⑥ : H blanking (before ROI)
- ⑦ : OffsetX
- ⑧ : Effective pixels for 1 line (after ROI)
- ⑨ : Entire effective pixels for 1 line (before ROI)
- ⑩ : Entire pixels for 1 line

To set several partial scan areas, make sure to set start positions and effective lines not to overlap with other areas.

- Frame Total Line Count = V Blanking Line Count + Partial Effective Line Count
Partial effective line count (excluding V blanking line count) must be ≤ 2064 .
(V blanking line count is Invalid Line + V Blank of Chart 3.5.2.1).
- Frame rate = $1 / (\text{Entire frame line count} \times \text{Time for 1 line})$
For Time for 1 line, refer to Chart 3.5.1.1.
- User can set partial scan settings with multiple of 8 from the Height 8.
- For manual shutter setting value with partial scan, effective line count becomes the maximum value (except for CLK sync trigger setting).
- 1 frame immediately after changing partial scan settings will become invalid frame. Especially with fixed trigger shutter mode and pulse width trigger shutter mode, input a dummy trigger once and use the second and after as regular video signals.

4.22. White Balance

AnalogControl	
BalanceRatioSelector	Red Blue
BalanceWhiteAuto	Off Once
BalanceRatio	0.00~8.00

- BalanceWhiteAuto: This is to adjust white balance gain automatically.
 - Off : Waiting
 - Once : Adjust white balance automatically with one push.

Select "Once" of BalanceWhiteAuto to adjust white balance once and return to off.

New gain of color composition selected by BalanceRatioSelector appears to BalanceRatio.

Shoot an object with achromatic color to full screen to execute BalanceWhiteAuto.

Recommendation is approx. 50% of signal level to execute.

The following commands are valid only when BalanceWhiteAuto is OFF.

- BalanceRatioSelector: This is to select color composition to change with BalanceRatio.
- BalanceRatio: User can set any values in the range of x0~x8 per 0.01 step for gain of the selected color composition. When BalanceRatioSelector = Red/Blue, white balance will be invalid if user sets 1.0 for both BalanceRatioRed and BalanceRatioBlue.

[Note]

- Please adjust white balance gain while camera is in operation. (White balance adjustment become invalid when camera is not outputting video).

4.23. Image Quality Selection Mode

- This is a function to select image quality of output images.

AnalogControl	
ImageQualityMode	StandardMode LowFrameRateMode

- Image Quality Mode: Image quality selection mode
 - StandardMode: Standard mode
 - LowFrameRateMode: This mode improves S/N compared to standard mode.

However, frame rate and sensitivity decrease. Frame rate will be the same value as 10bit. Enabled only when PixelFormat is BayerRG/GR/GB/BG 8.

With BayerRG/GR/GB/BG 10/12, mode will become StandardMode.

4.24. Shading Correction

- This is a function to correct the drop in the amount of peripheral light caused by lens and others.

AnalogControl	
ShadingCorrectionDataSelector	Off/Table1/Table2/Table3
DetectShading	(Execute)

- ShadingCorrectionDataSelector: This is to select a correction data and select where to save the detected correction data.
- Off: Disable shading correction.
- Table1~3: Enable shading correction with the selected correction value. Select Table from 1-3 and execute DetectShading to acquire correction data to the specified Table.

Before shading correction

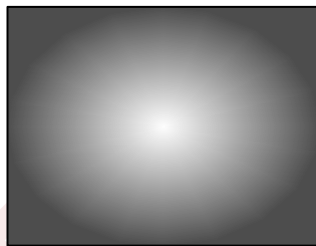

After shading correction

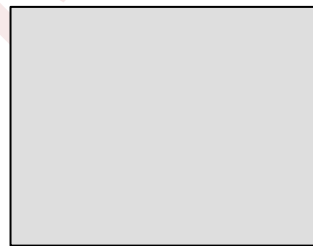

- DetectShading: Shoot an object with stable brightness such as pattern box to full screen to execute DetectShading. Function automatically calculates shading correction data and saves the calculated correction data in the selected table with ShadingCorrectionDataSelector.

[Note]

- Make sure to set full frame (1 region) to execute shading detection.
- Shading correction is disabled with multiple ROI (more than 2 effective regions).
- Acquire correction data when camera is in operation.
- Execute UserSetSave to save correction data of Table1~Table 3 to non-volatile memory at the same time.
- Correction data is not subject to Default of UserSetLoad.
- Make sure to turn ON ShadingCorrectionDataSelector.

4.25. Impulse Noise Filter

- This is a function to detect and remove impulse noises.

AnalogControl	
ImpulseNoiseFilter	On/Off
ImpulseNoiseFilterThreshold	0~4095

- ImpulseNoiseFilter: On/Off impulse noise filter.
Recommended ON when it is difficult to remove noises with defective pixels correction function explained in Section 4.26.
- ImpulseNoiseFilterThreshold: This is to specify strength of noise detection and removal function.
Recommendation is approx.256. Smaller values are effective but too small values may cause negative effect. 4095 setting is equivalent to function OFF.

[Note]

- ImpulseNoiseFilter is disabled with multiple ROI (more than 2 effective regions).

4.26. Defective Pixel Correction

- This is a function to detect, add, and correct defective pixels in output data from the sensor.
- There are two types of defective pixel data.
 - Defective data registered at factory
Black and white defective pixel data registered upon shipment from our factory. These data cannot be over-written.
 - Defective data registered by user
Data registered by user. In addition to the correction of defective pixel data registered upon shipment, we provide a method to update the defective pixel data. With DefectPixelDefault command, user can delete these user-registered data. This is not subject to UserSetDefault.
- User can register up to 256 points. (Note: Up to 64 points per CH.)

[CH (Channel)]

Camera performs image processing with 4 CH interleave.

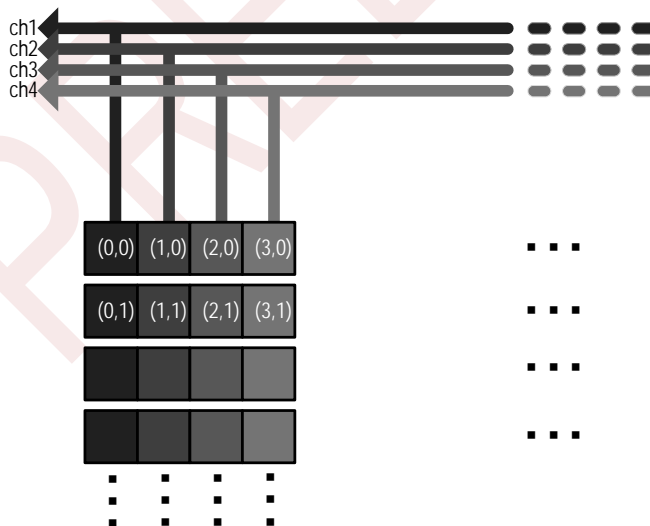

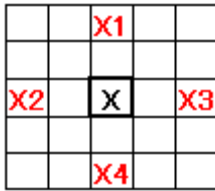

※With color model, defective pixel correction function calculates value for X pixel referring to the one separated peripheral pixels (in the same color elements).

When all peripheral pixels, shown as X1, X2, X3, and X4, are already registered as defective pixels, user cannot correct the X pixel.

Enable or disable Defective Pixel Correction

This is to enable or disable defective pixel correction function. Function controls both defective pixel correction data registered at factory and registered by user at one time.

AnalogControl	
DefectPixelCorrection	On/Off
DefectPixelAdd	(Execute)
DefectPixelAddOffsetY	0~2471
DefectPixelAddOffsetX	0~2063
DefectPixelDelete	(Execute)

Updating defective pixel data with coordinates X and Y.

This is to update defective pixel data by specifying coordinates to add or delete.

- DefectPixelCorrection: Enable or disable defective pixel correction function.
- DefectPixelAddOffsetX: Specify X coordinate
- DefectPixelAddOffsetY: Specify Y coordinate.
- Execute DefectPixelAdd to register the specified coordinates as defective pixels.
- Execute DefectPixelDelete to delete the specified coordinates from registered defective pixels.
- When user specify the same coordinates as those registered at factory, function ignores them.
- DefectPixelDelete command deletes only added pixels by user with DefectPixelAdd or DefectDetection.
- Data registered at factory is not subject to delete with DefectPixelDelete command.
- Registration and deletion of defective pixels by user is enabled only with full frame (1 Region, 2472x2064)
- When DefectDetectionStatus is error (0x000e0001 and 0x000e0002), DefectPixelAdd and DefectPixelDelete are disabled. Execute DefectPixelDefault to re-execute, or execute DefectDetection when DefectCorrectionMode is with Reacquire.

Updating defective pixel data with detection function

This is for user to detect and register correction data of white defect pixels.

AnalogControl	
DefectDetectionThesholdValue	0~4095
DefectDetection	(Execute)
DefectDetectionStatus	(Read Only)
DefectPixelDefault	(Execute)
DefectCorrectMode	Reacquire/Add

- DefectDetectionThesholdValue: This is to set a threshold value (0 ~ 4095: 12bit equivalent) for user defective pixel detection. Function registers data with luminance level that exceeds the threshold value specified here. With 10 bit images, specify a value of 4 times of signal level as a threshold value. With 8 bit images, specify a value of 16 times of signal level as a threshold value.
- DefectDetection: This is to detect defective pixels. Function automatically registers pixels that exceed the level specified with DefectDetectionThesholdValue.

- ※ Make sure to shield light from image sensor to execute.
- ※ Function reflects defective pixel correction registered by user immediately after execution.
- ※ Execute UserSetSave after DefectDetection to save data into non-volatile memory.
- ※ When DefectCorrectMode = Add and DefectDetectionStatus is error (0x000e0001 and 0x000e0002), DefectDetection command is disabled. Execute DefectPixelDefault or execute when DefectCorrectionMode is with Reacquire.

- DefectDetectionStatus: This is to indicate results of defective pixel detection proceeded by user.

0	No defective pixel correction data registered by user.
Value (Under 256)	Number of defective pixels detected and registered by user.
[Error code]	
0x000e0001 (917505)	Total number of defective pixel correction data exceeds the maximum number to register in one CH. (64)
0x000e0002 (917506)	Total number of defective pixel correction data exceeds the maximum number to register. (256 points) ※With some frame grabber board, error may be shown as decimal.

When an error code returns, check if user threshold value (DefectDetectionThresholdValue) is appropriate, as well as DefectivePixelCorrection.

- DefectPixelDefault: This is to delete entire defective pixel correction data registered by user.
 - ※ Function keeps defective pixel data for vertical flip OFF/ON in different tables separately. DefectPixelDefault deletes entire defective pixel correction data of the table currently in use. In other words, when user executes DefectPixelDefault when vertical flip is ON, function deletes entire defective pixel correction data of the table with vertical flip ON. The defective pixel correction data in the table of vertical flip OFF remains as it is.
- DefectCorrectMode: This is to select detection mode of defective pixels out of the followings.
 - Reacquire mode: This mode deletes defective pixel data except those registered by specifying coordinates and reacquire defective pixels.
 - Add mode: This mode acquires defective pixels in addition to the current pixels registered.

[Note]

- Make sure to acquire defective pixel correction data when camera is in operation.
- Make sure to turn OFF ROI mode to execute defective pixel correction. (Number of region must be 1 and the size must be 2472 x 2064 to execute).
- With high temperature, defective pixels increase. If defective pixels remain even when changing threshold value with DefectDetectionThresholdValue command, we recommend Impulse Noise Filter function explained in Section 4.25 as well.
- When DefectDetectionStatus becomes error (0x000e0001 and 0x000e0002), re-acquire defect pixels correction data as follows.
 - (1) Select DefectCorrectMode = Reacquire, change threshold value, and execute DefectDetection.
 - (2) Execute DefectPixelDefault to delete user-defect pixel correction data, change threshold value, and execute DefectDetection.

- Maximum number of defective pixels to register and to correct may not always be the same due to following reasons.
 - (1) With white defects detection, if one of interleave channel reaches the maximum number of defective pixels to register, correction stops. Function registers data up to that point, outputs error, and ends operation.
 - (2) When there is no effective pixel around the pixel to add (on the left, right, top, and bottom), user can register but cannot correct that pixel.

□ Indication of defective pixel coordinates

This is to indicate the coordinates of registered defective pixels by user and factory.

AnalogControl	
RegisteredDefectSelector	UserState/InitialState
DefectPixelNumber	1~256/1~768
DefectPixelOffsetX	(Read Only)
DefectPixelOffsetY	(Read Only)
DefectPixelType	(Read Only)

- RegisteredDefectSelector: Selection of defective pixel data to indicate.
 - UserState: Defective pixel correction data registered by user.
 - InitialState: Defective pixel correction data registered upon shipment from factory.
- DefectPixelNumber: This is to set a number of the registered defective pixels. Specify Table number of defective pixel data registered at factory and registered by user.
- DefectPixelOffsetX: This is to indicate X coordinate of the defective pixel specified with DefectPixelNumber. When user specifies a table number with no defective pixel data, it shows 65535.
- DefectPixelOffsetY: This is to indicate Y coordinate of the defective pixel specified with DefectPixelNumber. When user specifies a table number with no defective pixel data, it shows 65535.
- DefectPixelType: This is to indicate defect type of the pixel specified with DefectPixelNumber.
 - 1: White defects registered upon shipment from factory
 - 2: Black defects registered upon shipment from factory
 - 6: Defects registered by user
 - 7: Defects additionally registered by user
 - 65535: Table without defects

AnalogControl	
ChannelNumber	1~4
DefectPixelChannelCount	(Read Only)

- ChannelNumber: This is to specify channel number of defective pixel correction.
- DefectPixelChannelCount: Defective pixel count for the channel specified with ChannelNumber. This is the sum total of defective pixel with factory count and user register count.

4.27. Test Pattern Indication

- This is to display test pattern from camera. This is useful to check if your system is operating properly.

ImageFormatControl	
TestPattern	Off ColorBar ColorBarMoving

※ Displaying test pattern and cursor are mutually exclusive.

4.28. Cursor Indication

- This is to show cursor on your display screen.

ImageFormatControl	
CursorPattern	On/Off
CursorOffsetX	X coordinate
CursorOffsetY	Y coordinate
CursorColor	White/Black

※ Displaying test pattern and cursor are mutually exclusive.

- CursorPattern: Cursor indication On/Off.
- CursorOffsetX: X coordinate of vertical cursor.
- CursorOffsetY: Y coordinate of horizontal cursor.
- CursorColor: This is to select the color of cursor (black or white).

[Note]

- With partial scan (ROI), the left top of effective area becomes the origin (0,0) of cursor coordinates.
- With zooming out, cursor may be out of view .
- Due to color interpolation processing with grabber board, the cursor may be colored.

4.29. LED Operational Mode

- This is to change operational mode of LED at the rear of camera. For information on lighting patterns, refer to Section 3.3.3. LED Indicator.

DeviceControl	
DeviceIndicatorMode	Active ErrorStatus Inactive

- Active: Indication of communication status of CoaXPress.
- ErrorStatus: OFF with normal operation.
Lights only with system error.
- Inactive: ALL LED OFF

4.30. Camera Timing Output

- According to LineSource settings, camera outputs the following signals through pin No. 3 of 6pins circular connector.

Digital IO Control	
LineSelector	Line0
LineMode	Output
LineSource	OFF ExposureActive FrameActive LineActive TriggerPacketActive

- LineSource: Selection of output signals.
 - ExposureActive: This is to indicate exposure period of image sensor with Hi Active.
 - FrameActive: This is to indicate effective period of frame with Hi Active. (FVAL)
 - LineActive: This is to indicate effective period of video output line with Hi active. (LVAL)
 - TriggerPacketActive: This is to decode and output packet signals of uplink trigger from frame grabber. (LINK Trigger)

4.31. User ID

DeviceControl	
DeviceUserID	Manual
DeviceUserString	Manual

- Set a letter string as DeviceUserID with up to 16 characters and up to 256 characters as DeviceUserString including terminal NUL letter (\0). Execute UserSetSave to save these letter strings to camera non-volatile memory. These data are not subject to "UserSetLoad" with "Default."

※With some capture boards, characters more than 251 may not be indicated correctly.

4.32. Temperature Indication

- This is to indicate temperature of image sensor (°C). (converted value from temperature register value).

DeviceControl	
DeviceTemperatureSelector	Sensor (fixed)
DeviceTemperature	(Read Only)

- DeviceTemperatureSelector: This is to select the point of the device to measure temperature. Fixed with sensor (Sensor temperature) for VCC-5CXP7R.
- DeviceTemperature: This is to indicate temperature of the image sensor.

[Note]

- This is a reference temperature and not the actual temperature.

5. Factory Settings

Function	Data	Explanation
TriggerSelector	AcquisitionStart	Equivalent to TriggerMode=Off
TriggerMode	Off	Links with TriggerSelector
TriggerSyncMode	LineSync	Horizontal sync mode
TriggerSource	LinkTrigger0	CXP UP Link trigger
TriggerActivation	RisingEdge	Rising edge
ExposureTime	4999.0	Exposure time (4999us)
ExposureTimeMax	18126.0	Maximum value of exposure time (18126us)
Gain	1.00	x1.00
Gamma	1.00	Gamma coefficient =1.00
BalanceRatioSelector	Red	White balance gain color composition = Red
BalanceWhiteAuto	Off	White balance gain auto adjustment Off
BalanceRatio	1.00	White balance gain = x 1.00
DefectPixelCorrection	On	Defective pixel correction On
DefectPixelAddOffsetX	0	X coordinate of defective pixel correction
DefectPixelAddOffsetY	0	Y coordinate of defective pixel correction
DefectDetectionThresholdValue	200	Threshold value of defective pixel detection
ShadingCorrectionDataSelector	Off	Shading correction Off
ImageQualityMode	StandardMode	Image quality mode (Standard)
ImpulseNoiseFilter	Off	Impulse noise filter On/Off
ImpulseNoiseFilterThreshold	256	Threshold value of impulse noise filter
BlackOffset	0	Initial value of black level
PixelFormat	BayerRG8	RAW model
ConnectionConfig	CXP3_X1	CxpLinkConfiguration
TestMode	NormalOperation	Link test OFF to use
RegionSelector	EffectiveRegion	Partial area (ROI) number (Region0)
RegionMode	On	Partial area (ROI) On/Off
Width	2472	Partial area (ROI) width
Height	2064	Partial area (ROI) height
OffsetX	0	Partial area (ROI) X start position
OffsetY	0	Partial area (ROI) Y start position
ReverseX	False	Horizontal flip OFF
ReverseY	False	Vertical flip OFF
TestPattern	Off	Mutually exclusive with cursor indication
CursorPattern	Off	Mutually exclusive with test pattern
CursorOffsetX	1236	Cursor position X
CursorOffsetY	1032	Cursor position Y
CursorColor	White	Cursor color White/Black
DeviceIndicatorMode	Active	LED indicator
LineSource	Off	Circular connector 6P-3pin output
DeviceUserID		User set letter string (16 letters)
DeviceUserString		User set letter string (256 letters)

※ ConnectionConfig, PixelFormat, and ImageQualityMode are not subject to UserSetLoad.

6. Dimensions

6.1. Camera Dimensions

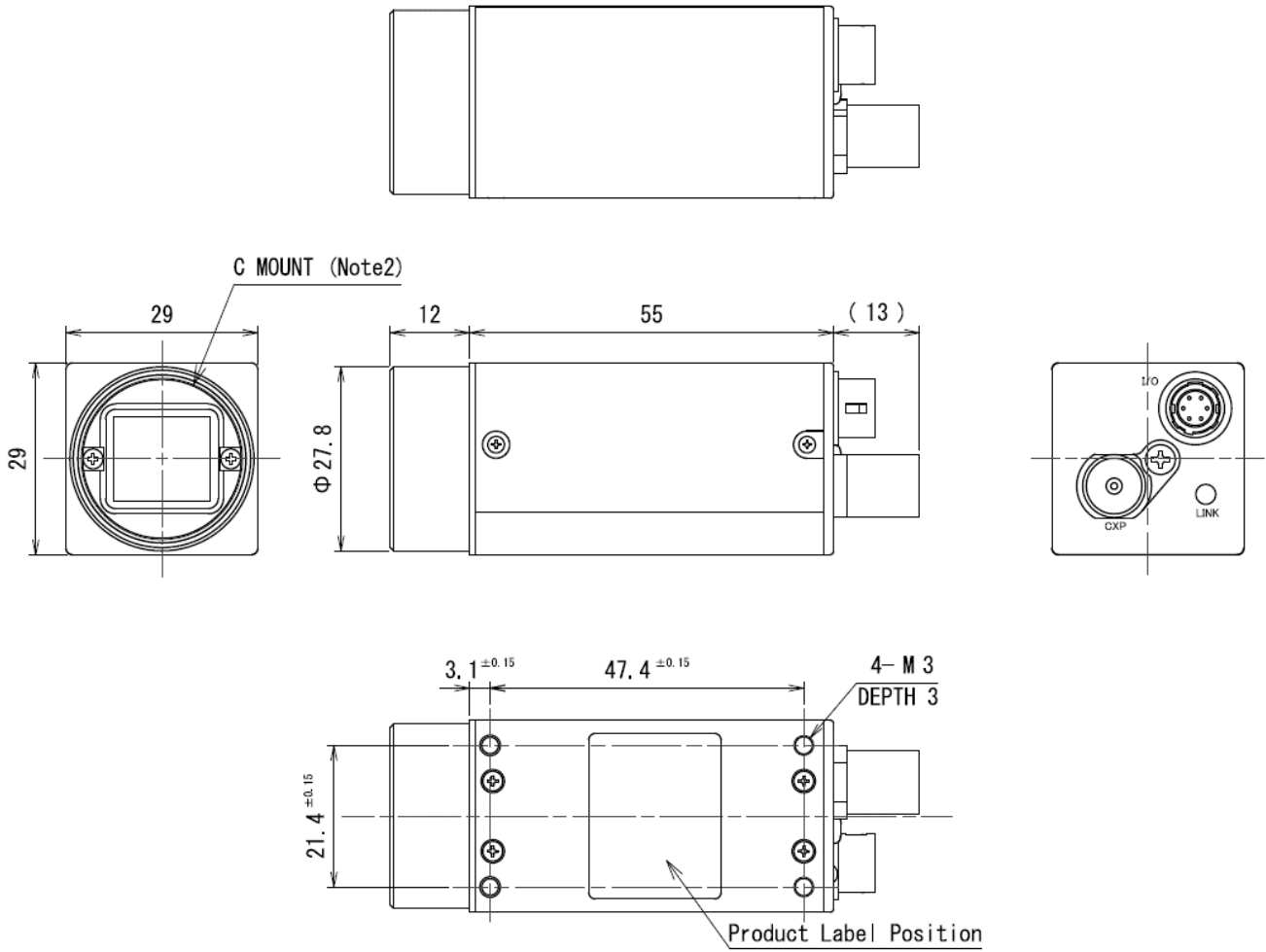

Note2) C mount screws comply with ANSI/ASME B1.1.1-32UN(2B).

Note1) Screw length from the lens mount surface shall be less than 6mm.
 And protruding portion of the C mount lens shall be less than 10mm.

PREVIEW

6.2. Optical Axis Accuracy

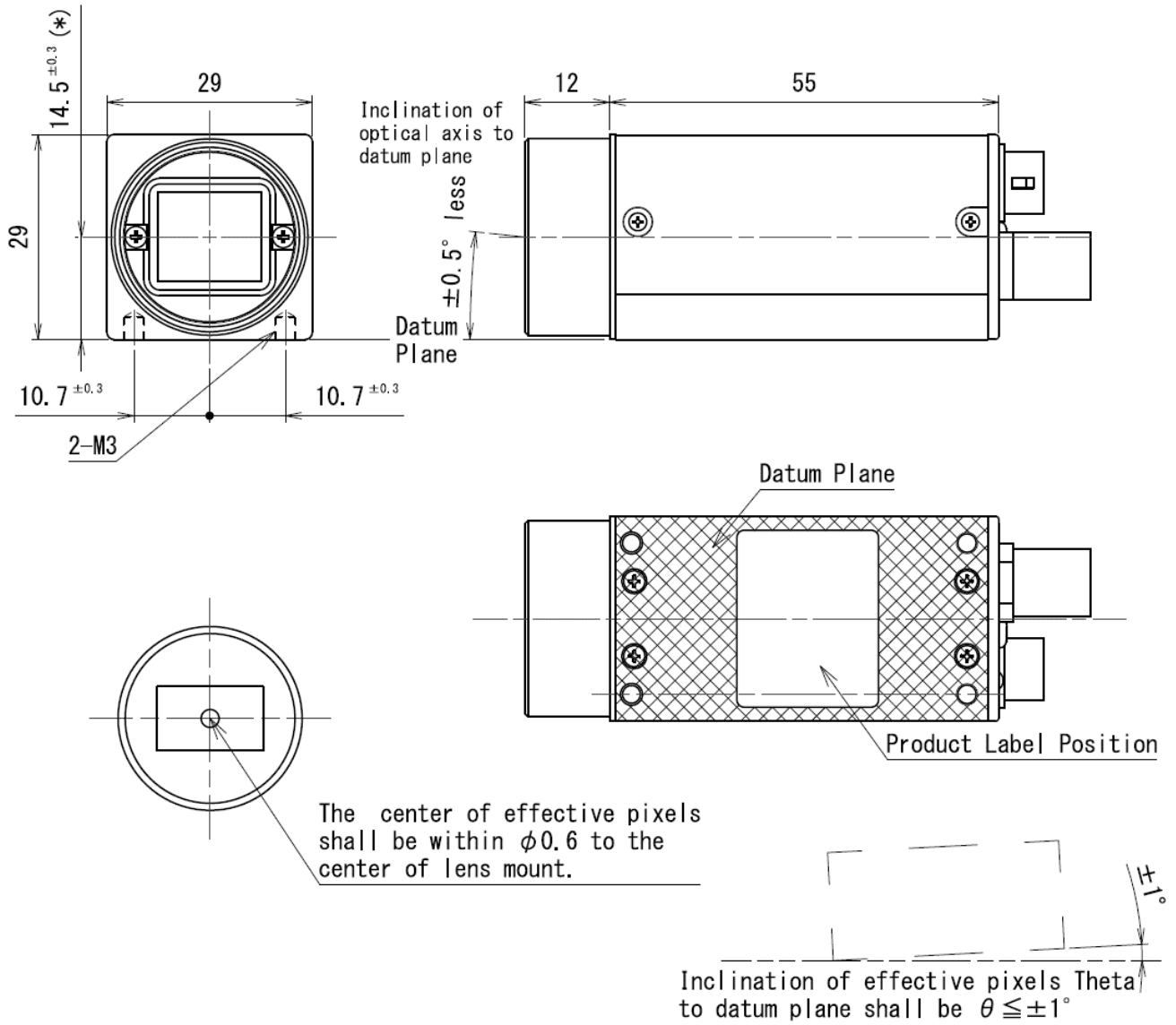

7. Case for Indemnity (Limited Warranty)

7.1. Product Warranty

The term of warranty of this product is within 3 years from the date of shipping out from our factory.

If you use the product properly and discover a defect during the warranty period, and if that was caused by designing or manufacturing, CIS Corporation, at its option, repairs or replaces it at no charge to you. Products out of warranty period will be subject to charge.

CIS should not hold responsible for damages or losses if;

- damages or losses are caused by earthquake, lightning strike, fire, flood or other acts of God.
- damages or losses are caused by deliberate or accidental misuse by user, or failure to observe the information contained in the instructions in this Product Specification and Operational Manual.
- damages or losses are caused by repair or modification conducted by customer or any unauthorized party.

7.2. CMOS Defective Pixels

CIS applies defective pixel correction prior to shipment of the product. However, the number of defective pixels are subject to increase due primarily to the effect of cosmic rays. Due to this nature, CIS should not hold responsible for the natural increase of defective pixels.

7.3. Product Support

Should you have any problems in function of the product you purchased, and if you need our further analysis and/or repair, please contact your local distributor.