CIS

CoaXPress I/F
1.6M pixels CMOS (B/W) Camera

VCC-SXCXP5M

Product Specifications
& Operational Manual

(Preliminary)

CIS Corporation

Table of Contents

1.	Handling Precautions	1
1.1.	Camera Handling Precautions.....	1
1.2.	Restrictions on Applications.....	1
1.3.	Disclaimers (Exception Clause)	1
2.	Product Outline	2
2.1.	Features.....	2
3.	Specifications.....	3
3.1.	General Specifications	3
3.2.	Input and Output Specifications	4
3.2.1	TRIGGER_IN (6pins circular connector, No.5 pin)	4
3.2.2	SIGNAL_OUT (6pins circular connector, No.3 pin)	4
3.3.	External Connector Pin Assignment.....	5
3.3.1	6pins Circular Connector (I/O).....	5
3.3.2	75Ω BNC Connector	5
3.3.3	LED Indicator	5
3.4.	Spectral Response.....	6
3.5.	Frame Rate	6
3.5.1	Frame rate of Internal Trigger Sync. Mode.....	6
3.5.2	Frame rate of External Trigger Sync. Mode	7
4.	Camera Functions.....	7
4.1.	Camera Interface	7
4.2.	How to Save and Initialize Settings	7
4.3.	Link Speed and Link Count.....	8
4.4.	Pixel Format	8
4.5.	Flip	8
4.6.	Trigger Mode	9
4.6.1	Internal Sync. Mode (Free run mode)	10
4.6.2	External Trigger Sync Mode.....	10
4.6.3	Fixed trigger shutter mode + H sync trigger (LineSync)	11
4.6.4	Fixed trigger shutter mode + CLK sync. trigger (ClockSync)	12
4.6.5	Pulse width trigger shutter mode + H sync. trigger (LineSync)	13
4.6.6	Pulse Width Trigger Shutter Mode + CLK Sync. Trigger (ClockSync)	14
4.6.7	Restrictions on Trigger Pulse Input Timing.....	15
4.7.	Exposure Time.....	17
4.7.1	Formula to Calculate Manual Shutter Values with H Sync Mode	17
4.8.	Gain.....	17
4.9.	Black Level Adjustment.....	17
4.10.	Partial Scan (ROI)	18
4.11.	Defective Pixel Correction	19
4.12.	Test Pattern Indication.....	22
4.13.	Cursor Indication	23
4.14.	LED Operational Mode	23
4.15.	Camera Timing I/O	23
4.16.	User ID	24
4.17.	Temperature Indication.....	24
4.18.	Connection Reset	24
4.19.	Gamma Correction	25
4.20.	Image Quality Selection Mode	25
4.21.	Shading Correction.....	25
5.	Factory Settings	27

6	Dimensions.....	28
6.1	Camera Dimensions.....	28
6.2	Optical Axis Accuracy.....	29
7	Case for Indemnity (Limited Warranty).....	30
7.1	Product Warranty.....	30
7.2	CMOS Defective Pixels.....	30
7.3	Product Support.....	30

PRELIMINARY

1. Handling Precautions

1.1. Camera Handling Precautions

- Do not use or store camera in dusty or humid places.
- Do not apply excessive force, vibration, or static electricity that could damage camera. Please handle camera with care.
- Do not shoot direct images that are extremely bright (e.g., strong light source, sun, etc.). When extremely strong light source is shot, smear or blooming may occur. Put the lens cap on when camera is not in use.
- Follow the instructions in [Chapter 3.3., "External Connector Pin Assignment"](#) for connecting camera. Improper connection may cause damages not only to the camera but also to the connected devices.
- Confirm mutual ground potential carefully before connecting camera to monitors or computers. Any AC leak from the connected devices may cause damages or destroy the camera.
- Do not apply excessive voltage. (Use only the specified voltage.) Unstable or improper power supply voltage may cause damages or malfunction of the camera.
- Our warranty does not apply to damages or defects caused by irregular and/or abnormal use of the product.

Our warranty does not apply to damages or defects caused by neglecting the instructions and precautions explained in this manual.

1.2. Restrictions on Applications

- The camera must not be used for any nuclear equipment or aerospace equipment with which mechanical failure or malfunction could result in serious bodily injury or loss of human life.
- The camera must not be used under conditions or environments other than those specified in this manual.

1.3. Disclaimers (Exception Clause)

CIS should not be liable for any damages or losses if;

- damages or losses are caused by earthquake, lightning strike, fire, flood, or other acts of God.
- damages or losses are caused by deliberate or accidental misuse by user, or failure to observe information and instructions explained in this manual.
- damages or losses are caused by repair or modification conducted by user or any unauthorized party.

2. Product Outline

VCC-SXCXP5M is B/W camera with CoaXPress interface. Using 1/2.9", global shutter type 1.6M pixels CMOS image sensor. Complies with CoaXPress Version 1.1.1. Must have function ready for Machine Vision applications such as trigger shutter, ROI, Gain, black level adjustment, defective pixel correction, and PoCXP. Suitable for various FA/Machine vision applications.

2.1. Features

- Small footprint: 29mm (H) x 29mm (W) x 29mm (D)
- Global shutter type CMOS sensor
- Complies with CoaXPress CXP-3 and CXP-6
- 1 lane
- Cable length: Max. 30m
- Exposure setting, Gain setting
- External trigger mode (Internal sync. / Fixed trigger shutter mode / Pulse width trigger shutter mode)
- Complies to GenICam
- C mount

PRELIMINARY

3. Specifications

3.1. General Specifications

Electrical Specifications			
Image sensor	Sensor type	1/2.9", Global shutter type CMOS sensor	
	Effective pixels	1456(H) × 1088(V)	
	Unit cell size	3.45μm(H) × 3.45μm(V)	
Interface		Complies with CoaXPress ver, 1.1.1 Supports CXP6/CXP3 x1 lane	
Video output format		Mono8/Mono10/Mono12	
Frame rate	CXP-3 8/10/12bit	172fps/138fps/115fps	
	CXP-6 8/10/12bit	276fps/226fps/165fps	
Sync. system		Internal sync.	
Resolution (The maximum pixel size)		1456 (H) × 1088(V)	
Video signals (Gain 0dB)	White clip level	255dig	with Mono 8bit
	Set up level	0~2dig	with Mono 8bit
	Dark shading	4dig or less for both horizontal and vertical	with Mono 8bit
Sensitivity		TBD 12bit/10bit Mode F8 400lx 3200K 1/30s Gain 0dB 8bit Mode F16 400lx 3200K 1/30s Gain 0dB	
Minimum illumination		TBD 12bit/10bit Mode 0.06lx (F1.4, Gain 42dB, 1/30s, Level=50%) 8bit Mode 0.02lx (F1.4, Gain 42dB, 1/30s, Level=50%)	
Gain variable range		x1~x256 (0dB~+48dB)	
Shutter speed		Manual setting	
Gamma correction		Coefficients of 0.10~1.80 are valid.	
Trigger mode		Free run mode (Camera internal trigger) Trigger mode (Host, External terminal) • Fixed trigger shutter • Pulse width trigger shutter	
Partial scan		User can set vertical/horizontal 1 area.	
Power requirements		PoCXP: 18.5~26V	
Power consumption (Max)		2.95W(CXP-3), 3.15W(CXP-6) [with free run]	
Mechanical Specifications			
Dimensions		H:29mm W:29mm D:29mm excluding projection.	
Weight		Approx. 50g	
Lens mount		C mount	

Environmental Specifications			
Safety/Quality Standards			
CE: EMC: 2014/30/EU Emission: EN61000-6-4:2007+A1:2011 Immunity: EN61000-6-2:2019			
RoHS: 2011/65/EU (EU)2015/863 EN50581 (RoHS2)			
Durability	Vibration	Acceleration	: 98m/s ² (10G)
		Frequency	: 20~200Hz
		Direction	: X, Y, and Z 3 directions
		Testing time	: 120min for each direction
	Shock	No malfunction with 980m/s ² (100) G for ±X, ±Y, and ±Z, 6 directions without packaging.	
Operational temperature		0 ~ +45°C Humidity: 20 ~ 80%RH with no condensation.	
Storage temperature		-30 ~ +60°C Humidity: 20 ~ 80%RH with no condensation.	

3.2. Input and Output Specifications

3.2.1 TRIGGER_IN (6pins circular connector, No.5 pin)

- 5.0V, 3.3V CMOS level / TTL level
- Input voltage Low: 0.5Vdc (Max), High: 2.1Vdc (Min)
- Triggers can be input directly from the external equipment. To use this terminal, set TriggerSource of AcquisitionControl to Line0.

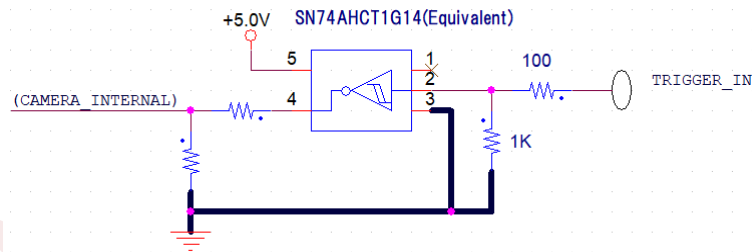

3.2.2 SIGNAL_OUT (6pins circular connector, No.3 pin)

- 5.0V CMOS logic level output
- Output voltage Low: 0.55Vdc (Max), High: 3.8Vdc (Min)
- This is to output timing signals generated in the camera. Set the signal to output with LineSource of DigitalIOControl.

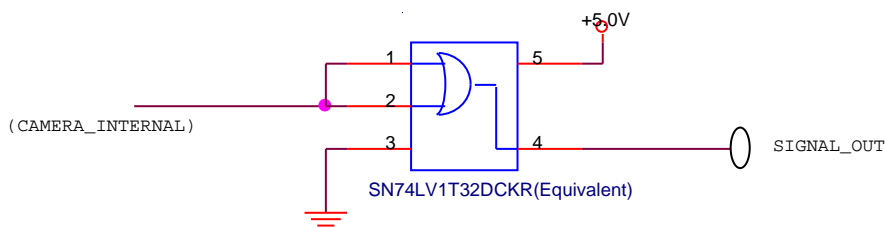

3.3. External Connector Pin Assignment

3.3.1 6pins Circular Connector (I/O)

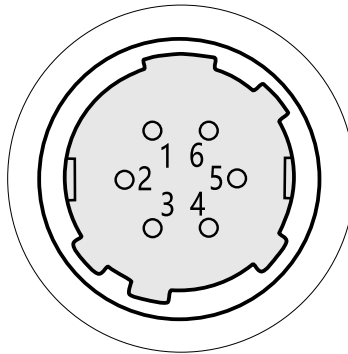

HR10-7R-6PA (Hirose) or equivalent

Pin No.	Signals	Description
1	NC	
2	NC	
3	Line1	SIGNAL_OUT (Exposure/FVAL/LVAL/LinkTrigger)
4	NC	
5	Line0	TRIGGER_IN
6	GND	Electrically connected with camera chassis.

※NC=Non-Connection. Do not connect anything to the terminal.

3.3.2 75Ω BNC Connector

- CoaXPress video output signal.

CXP (For PoCXP)

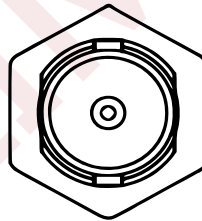

3.3.3 LED Indicator

With LED indicator Active, lighting patterns show the camera status by its way of lighting.

LED	Camera status
OFF	No power supply.
Green lighting	Completion of connection between device and host.
Green fast blinking [12.5Hz]	Transmitting video data.
Orange slow blinking [1Hz]	Waiting for a trigger input.
Red fast blinking [12.5Hz]	System error or inappropriate trigger input.

3.4. Spectral Response

※ Excludes characteristics of lens, optical glass, and light source.

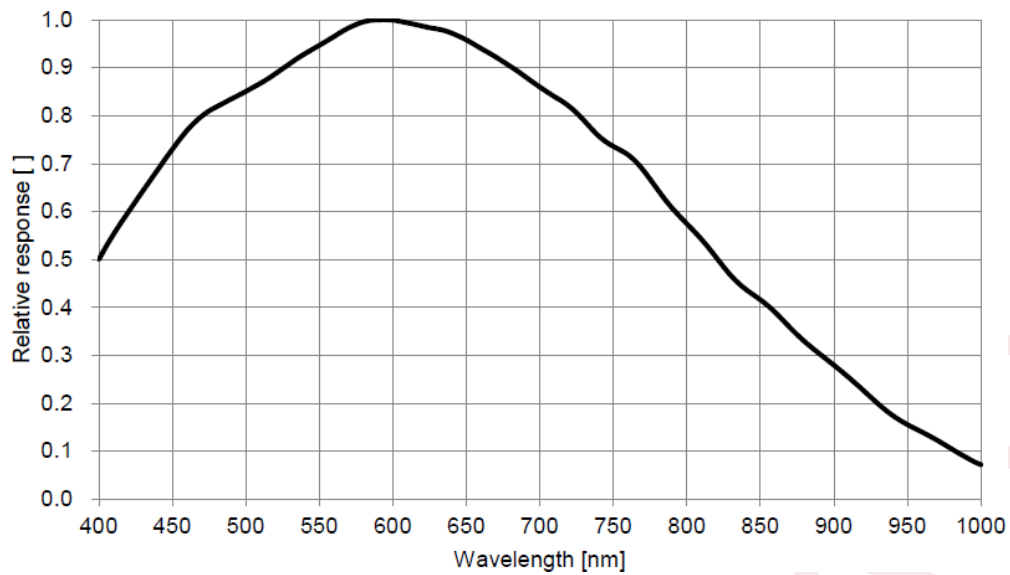

3.5. Frame Rate

3.5.1 Frame rate of Internal Trigger Sync. Mode

[Formula for calculating frame rate]

$$\text{Frame rate} = 1/(\text{Time for 1 line} \times (\text{Output video line number} + 42)) \text{ [fps]}$$

Please refer to the following table for the time for 1 line and frame rate value with full size output.

※ Frame rate with full size = 1/(Time for 1 line x (1088 + 42))

LinkConfig	PixelFormat	Time for 1 line [μs]	Frame rate with full size [fps]	Frame time with full size [ms]
CXP-6	Mono8	3.21	276.1	3.63
	Mono10	3.91	226.6	4.41
	Mono12	5.33	165.9	6.03
CXP-3	Mono8	5.12	172.9	5.78
	Mono10	6.41	138.0	7.25
	Mono12	7.68	115.3	8.67

The following command enables to readout frame rate of internal sync. mode.

AcquisitionControl	
AcquisitionFrameRate	(ReadOnly)

◆ AcquisitionFrameRate: This is to indicate the frame rate with internal sync. mode (free run mode).

※ Even with external trigger mode, frame rate with internal sync. mode will be shown.

3.5.2 Frame rate of External Trigger Sync. Mode

The maximum frame rate with H sync. trigger (LineSync) mode is the value of the internal sync. mode in the previous page.

User can calculate the maximum frame rate with CLk sync. trigger (ClkSync) mode with the formula below.

$$\text{Max. frame rate} = 1/(\text{Exposure time} + (\text{Time for 1 line} \times (\text{Output image line number} + 42)))$$

※ Set trigger input with the cycle less than the Max. frame rate above.

※ Please refer to [Section 3.5.1. Frame rate of Internal Trigger Sync. Mode](#) for the time for 1 line.

※ Please refer to [Section 4.6.2. External Trigger Sync Mode](#) for the details on external sync .mode.

4. Camera Functions

4.1. Camera Interface

- Complies with CoaXPress 1.1.1 standard.

4.2. How to Save and Initialize Settings

- Execute "UserSetSave" to save settings into camera non-volatile memory. Camera loads the saved settings upon next rebooting.

UserSetControl	
UserSetSelector	Default UserSet0
UserSetLoad	(Execute)
UserSetSave	(Execute)

- ◆ UserSetSelector : This is to save the current setting values or to select setting values saved in non-volatile memory to readout.
 - Default : Factory settings (User can execute UserSetLoad only. UserSetSave is not subject to save.)
 - UserSet0 : User settings
 - ※ Default (Factory setting) is not subject to save.

Values of UserSetSelector are not subject to save with UserSetSave. The values always become Default upon next rebooting. Please set values before executing UserSetLoad or UserSetSave.

- ◆ UserSetLoad : Load the saved settings from the area selected with UserSetSelector.
- ◆ UserSetSave : This is to save the current setting values to the area selected with UserSetSelector. Make sure to set UserSetSelector to UserSet0 before executing.
 - Do not execute UserSetLoad while grabbing (acquiring images).
 - Defective pixel correction values, DeviceUserID, and DeviceUserString are not subject to UserSetLoad for Default. (Camera keeps those values.)
 - ConnectionConfig, PixelFormat, and ImageQualityMode are not subject to UserSetLoad so that camera keeps values in operation. If you wish to change those values, set values with each command.

Please refer to the table below for the combination for save settings and execute calling.

UserSetSelector	UserSetLoad/Save	Status
Default	UserSetLoad	Call factory settings.
	UserSetSave	- (Not subject to execute.)
UserSet0	UserSetLoad	Call user settings.
	UserSetSave	Save user settings.

4.3. Link Speed and Link Count

Transfer Control	
ConnectionConfig	CXP3_X1 CXP6_X1

- ConnectionConfig : Selection of link speed and link count
 CXP3_X1 : Link speed=3.125Gbps, Link count=1
 CXP6_X1 : Link speed=6.250Gbps, Link count=1
 ※ Do not change ConnectionConfig while grabbing (acquiring images).

4.4. Pixel Format

ImageFormatControl	
PixelFormat	Mono8 Mono10 Mono12

- PixelFormat : Selection of pixel format.
 Mono8 : Monochrome 8bit
 Mono10 : Monochrome 10bit
 Mono12 : Monochrome 12bit
 ※ Do not change PixelFormat while grabbing (acquiring images).

4.5. Flip

ImageFormatControl	
ReverseX	True/False
ReverseY	True/False

- ReverseX : Flip the image in X direction.
- ReverseY : Flip the image in Y direction.
- ※ Do not change ReverseX/Y while grabbing (acquiring images).
- ※ When executing Flip operation with ROI at the same time, the origin coordinate (0) will be on the displaying screen regardless of On/Off of flip setting. The coordinates associated with the setting order of ReverseY and ROI are shown in the next page.

• Flip operation with ROI

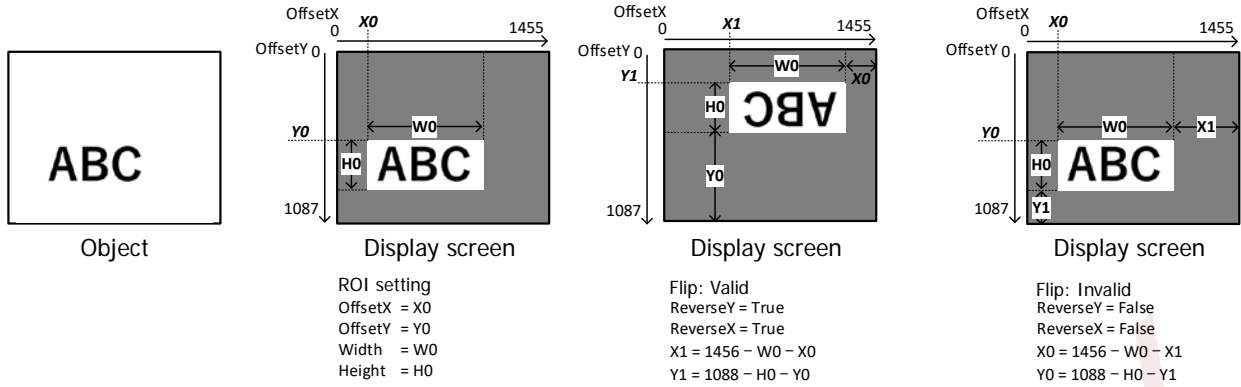

• ROI operation with flip

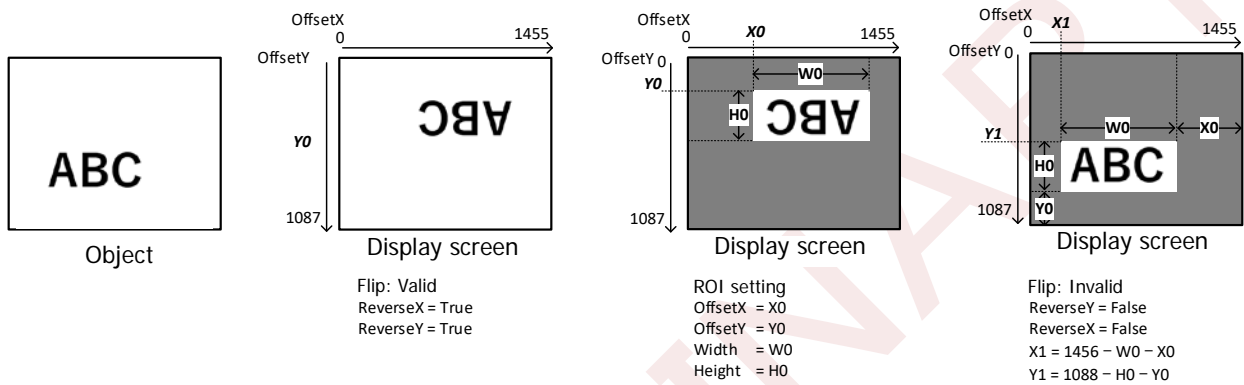

4.6. Trigger Mode

There are 2 types of trigger mode; internal sync. mode and external trigger mode. Trigger mode is selectable from the following command.

Acquisition Control	
TriggerMode	Off/On
TriggerSelector	AcquisitionStart FrameStart

- TriggerMode: Trigger mode (Link with TriggerSelector)
 - Off: Operates with internal sync. mode (free run mode) (TriggerSelector = AcquisitionStart)
 - On: Operates with external trigger mode. (TriggerSelector = FrameStart)
 - ※ Do not change TriggerMode while grabbing (acquiring image).
- TriggerSelector: Trigger selector (Link with TriggerMode)
 - AcquisitionStart: Operates with internal sync. mode (Free run mode) (TriggerMode = Off)
 - FrameStart: Operates with external trigger mode (TriggerMode = On)
 - ※ Do not change TriggerSelector while grabbing (acquiring image).

4.6.1 Internal Sync. Mode (Free run mode)

- This is a mode to use internal triggers continuously generated in the camera.
- Set TriggerMode Off, and set TriggerSelector to AcquisitionStart.
 - ※ When TriggerSyncMode is ClockSync, user cannot turn TriggerMode Off. Make sure to set TriggerSyncMode to LineSync.
- Please refer to [Section 3.5.1. Frame rate of Internal Trigger Sync. Mode](#) for frame rate.
- Set exposure time with ExposureTime command. Please refer to [Section 4.7. Exposure Time](#).
- The following shows the timing chart and the timing parameter with internal sync. mode.

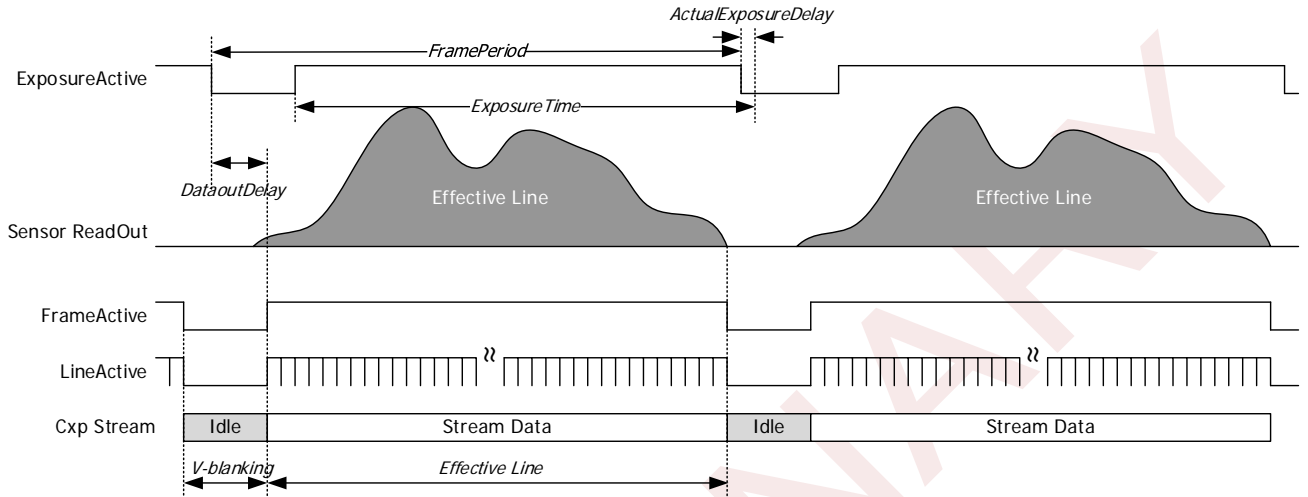

Vertical sync. timing chart (with free run) TriggerMode=Off

Timing Parameter	Value	Description
Dataout Delay	39	Time from ExposureActive falling to FrameActive rising [H]
V-blanking	42	Vertical blanking line number [H]
Actual Exposure Delay	14.26	Delay time from ExposureActive falling to completion of exposure inside the sensor. [μ s]

- ※ Please refer to the time for 1 line in [Section 3.5.1. Frame rate of Internal Trigger Sync. Mode](#) for time for 1H.
- ※ ExposureActive is output for the amount of time obtained by subtracting the Actual Exposure Delay from the ExposureTime setting.

4.6.2 External Trigger Sync Mode

- This is a mode to input external trigger signals to capture images by any preferred timings.
- Turn on TriggerMode, and set TriggerSelector to FrameStart. When TriggerMode is off, the camera will become internal sync. mode.
- User can select detailed function with following commands. (Make sure to stop inputting triggers while selecting function.)

Acquisition Control	
TriggerSyncMode	LineSync ClockSync
TriggerSource	LinkTrigger0 Line0 Software
TriggerSoftware	(Execute)
TriggerActivation	RisingEdge FallingEdge LevelHigh LevelLow

- ♦ TriggerSyncMode:
 - LineSync: H sync. trigger mode (Control exposure time per line)
 - ※ High frame rate operation is valid by overlapping operation (exposure while readout images).
 - ※ Since it synchronizes with H, 1 line of jitter may occur for external trigger input.
 - ClockSync: CLK sync. trigger mode (Control exposure time per sensor clock)
 - ※ Overlapping operation (exposure while readout images) is invalid.
 - ※ Since it synchronizes with CLK, this mode can start exposure with low-latency for external trigger input.

- ♦ TriggerSource: This is to select where to send external triggers.
 - LinkTrigger0: External trigger input from CoaXPress Host Device.
 - Please refer to specification manuals of the Host Device such as frame grabber board to know how to generate triggers.
 - Line0: External trigger input from 6pins circular connector.
 - Software: Input trigger with TriggerSoftware command.
- ※ Software Trigger is valid when TriggerActivation is Rising Edge.

- ♦ TriggerSoftware: Camera generates a trigger to capture one frame image by executing this command.
 - Make sure to set TriggerSource to Software.

- ♦ TriggerActivation: This is to select how to start capturing video or its polarity.
 - RisingEdge: Fixed trigger shutter mode: Start exposure (Timed) with rising edge.
 - FallingEdge: Fixed trigger shutter mode: Start exposure (Timed) with falling edge. (※)
 - LevelHigh: Pulse width trigger shutter mode: Exposure during high active period. (TriggreWidth)
 - LevelLow: Pulse width trigger shutter mode: Exposure during low active period. (TriggreWidth) (※)
- ※ When set FallingEdge and LevelLow with LinkTrigger0, disturbance images may occur at the first time grabbing after setting.

Combination of trigger mode

※ Please refer to the next section for the detail on each combination.

No	TriggerMode	TriggerSyncMode	TriggerActivation	TriggerSource
1	Off	LineSync	-	-
2	On	LineSync	RisingEdge/FallingEdge	LinkTrigger0/Line0/Software
3	On	ClockSync	RisingEdge/FallingEdge	LinkTrigger0/Line0/Software
4	On	LineSync	LevelHigh/LevelLow	LinkTrigger0/Line0
5	On	ClockSync	LevelHigh/LevelLow	LinkTrigger0/Line0

4.6.3 Fixed trigger shutter mode + H sync trigger (LineSync)

(TriggerMode=On, TriggerSyncMode=LineSync, TriggerActivation= RisingEdge)

- This is a mode to start exposure with external trigger input and expose for a set period.
- Trigger operation is H sync. Also, high speed operation is valid since user can input next trigger while reading out images (=overlap). However, 1H jitter will occur to exposure timing due to H sync. operation.
- Set Frame rate (=trigger input cycle) lower than Max. frame rate explained in [Section 3.5.2. Frame rate of External Trigger Sync. Mode.](#)
- There is a restriction for trigger input. Please refer to [Section 4.6.7. Restrictions on Trigger Pulse Input Timing.](#)
- The diagram in the next page shows the timing chart and the timing parameter with internal sync. mode + H sync trigger (LineSync).

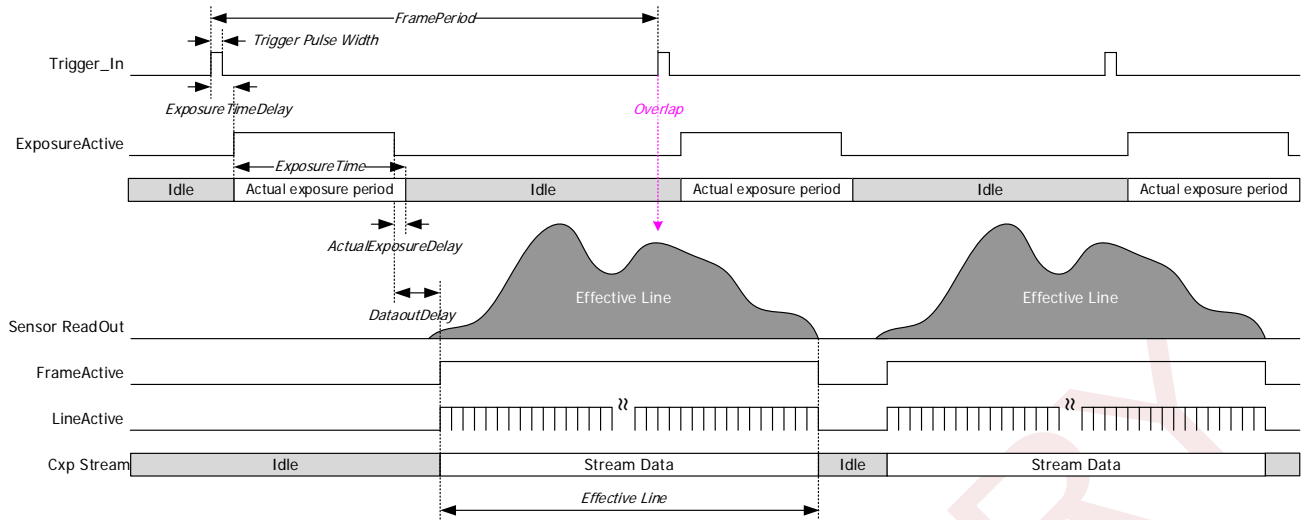

Vertical sync. timing chart (Fixed trigger shutter mode + H sync. trigger (LineSync))

Timing Parameter	Value	Description
Trigger Pulse Width	1	Trigger input pulse width (Min. value) [H]
Exposure Time Delay	2 ~ 3	Delay time from trigger input rising to ExposureActive rising [H]
Actual Exposure Delay	14.26	Delay time from ExposureActive falling to completion of exposure inside the sensor [μ s]
Dataout Delay	39	Time from ExposureActive falling to FrameActive rising [H]

※ Please refer to the time for 1 line in [Section 3.5.1. Frame Rate of Internal Trigger Sync. Mode](#) for time for 1H.

※ ExposureActive is output for the amount of time obtained by subtracting the Actual Exposure Delay from the ExposureTime setting.

4.6.4 Fixed trigger shutter mode + CLK sync. trigger (ClockSync)

(TriggerMode=On, TriggerSyncMode=ClockSync, TriggerActivation= RisingEdge)

- This is to start exposure with external trigger input, and expose for a set period.
- Since it synchronizes with CLK, this mode can start exposure with low-latency for external trigger input. However, user cannot input the next trigger while reading out images.
- Set Frame rate (=trigger input cycle) lower than Max. frame rate explained in [Section 3.5.2. Frame rate of External Trigger Sync. Mode](#).
- There is a restriction for trigger input. Please refer to [Section 4.6.7. Restrictions on Trigger Pulse Input Timing](#).
- The following shows the timing chart and the timing parameter with fixed trigger shutter mode + CLK sync trigger (ClockSync).

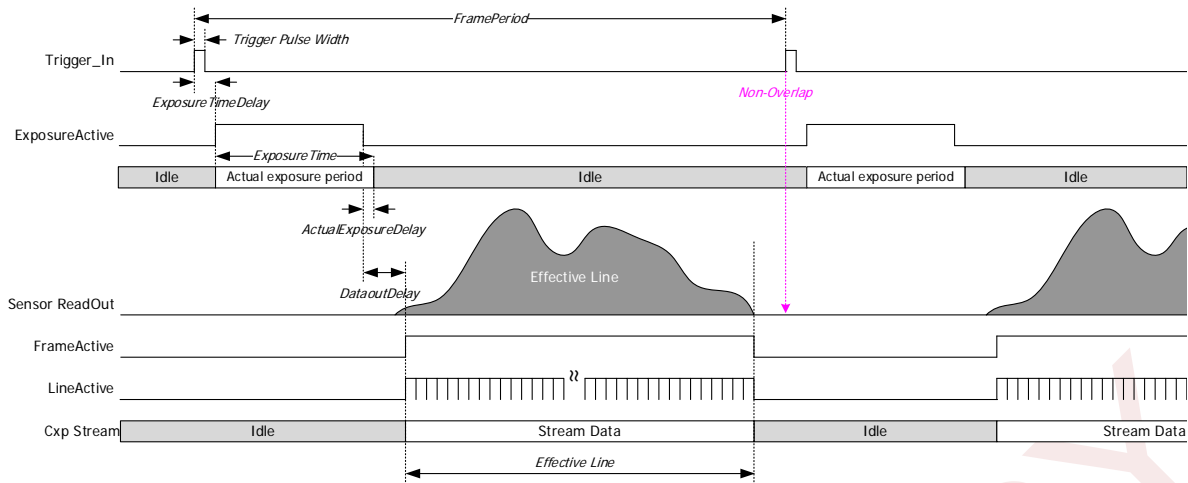

Vertical sync. timing chart (Fixed trigger shutter mode + CLK sync. trigger (ClockSync))

Timing Parameter	Value	Description
Trigger Pulse Width	1	Trigger input pulse width (Min. value) [μ s]
Exposure Time Delay	0.013	Delay time from trigger input rising to ExposureActive rising [μ s]
Actual Exposure Delay	14.26	Delay time from ExposureActive falling to completion of exposure inside the sensor [μ s]
Dataout Delay	39	Time from ExposureActive falling to FrameActive rising [H]

- ※ Please refer to the time for 1 line in [Section 3.5.1. Frame rate of Internal Trigger Sync. Mode](#) for time for 1H.
- ※ ExposureActive is output for the amount of time obtained by subtracting the Actual Exposure Delay from the ExposureTime setting.

4.6.5 Pulse width trigger shutter mode + H sync. trigger (LineSync)

(TriggerMode=On, TriggerSyncMode=LineSync, TriggerActivation=LevelHigh)

- This is to start exposure with external trigger input, and control exposure time with trigger pulse width.
- Trigger operation is H sync. Also, high speed operation is valid since user can input next trigger while reading out images (=overlap). However, 1H jitter will occur to exposure timing due to H sync. operation.
 - ※ 1H jitter may occur at the equivalent of exposure start and exposure end.
- Camera can operate long time exposure by extending trigger pulse width. However, noises such as dark noise and shading noise may be noticeable.
- Set Frame rate (=trigger input cycle) lower than Max. frame rate explained in [Section 3.5.2. Frame rate of External Trigger Sync. Mode](#).
- There is a restriction for trigger input. Please refer to [Section 4.6.7. Restrictions on Trigger Pulse Input Timing](#).
- The diagram in the next page shows the timing chart and the timing parameter with pulse width trigger shutter mode + H sync. trigger (LineSync)

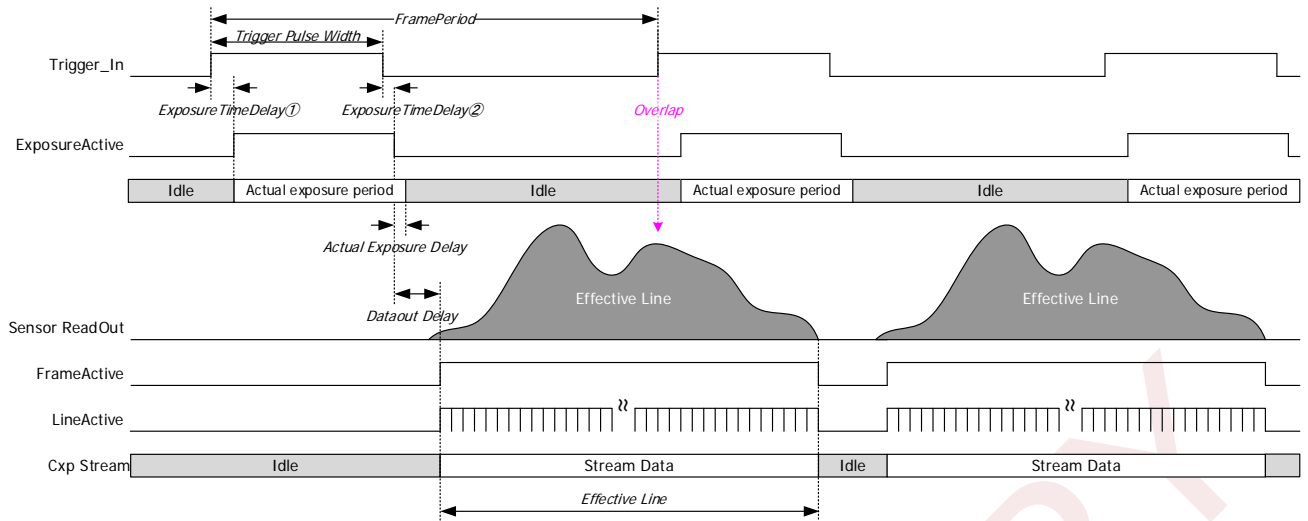

Vertical sync. timing chart (Pulse width trigger shutter mode + H sync. trigger (LineSync))

Timing Parameter	Value	Description
Trigger Pulse Width(min) (max)	1	Trigger input pulse width (Min. value) [H]
	200	Trigger input pulse width (Max. value) [ms]
Exposure Time Delay ①	2 ~ 3	Delay time from trigger input rising to ExposureActive rising [H]
Exposure Time Delay ②	2 ~ 3	Delay time from trigger input falling to ExposureActive falling [H]
Actual Exposure Delay	14.26	Delay time from ExposureActive falling to completion of exposure inside the sensor [μs]
Dataout Delay	39	Time from ExposureActive falling to FrameActive rising [H]

※ Please refer to the time for 1 line in [Section 3.5.1. Frame rate of Internal Trigger Sync. Mode](#) for time for 1H.

4.6.6 Pulse Width Trigger Shutter Mode + CLK Sync. Trigger (ClockSync) (TriggerMode=On, TriggerSyncMode=ClockSync, TriggerActivation=LevelHigh)

- This is to start exposure with external trigger input, and control exposure time with trigger pulse width.
- Since it synchronizes with CLK, this mode can start/end exposure with low-latency for external trigger input. User cannot input next trigger while reading out images.
- Set Frame rate (=trigger input cycle) lower than Max. frame rate explained in [Section 3.5.2. Frame rate of External Trigger Sync. Mode](#).
- There is a restriction for trigger input. Please refer to [Section 4.6.7. Restrictions on Trigger Pulse Input Timing](#).
- The diagram in the next page shows the timing chart and the timing parameter with pulse width trigger shutter mode + CLK sync. trigger (ClockSync)

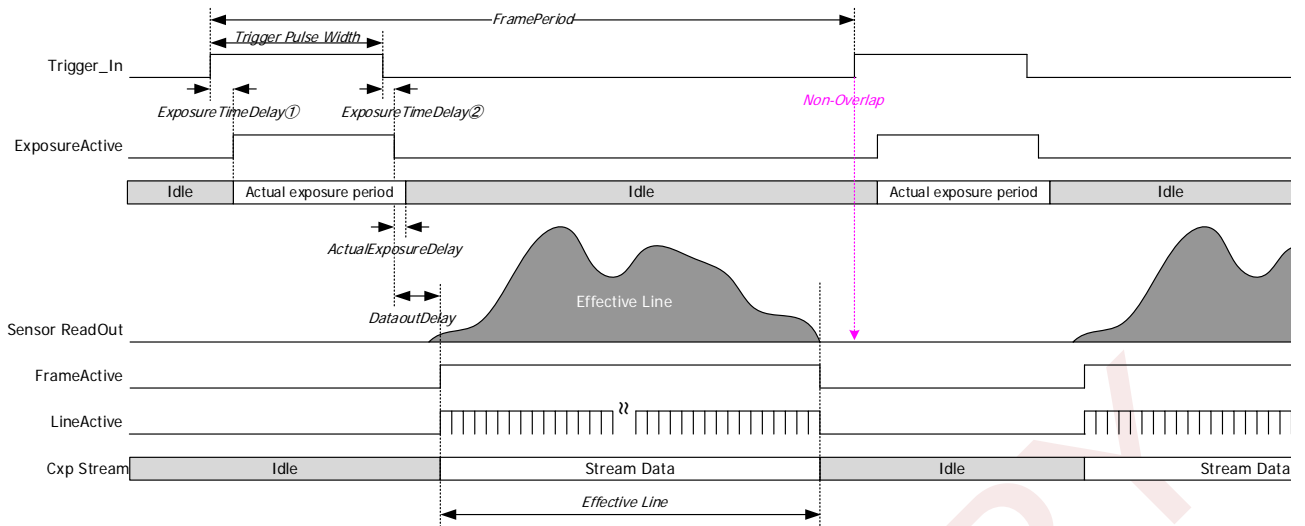

Vertical sync. timing chart (Pulse width trigger shutter mode + CLK sync. trigger (ClockSync))

Timing Parameter	Value	Description
Trigger Pulse Width(min) (max)	15	Trigger input pulse width (Min. value) [μ s]
	200	Trigger input pulse width (Max. value) [ms]
Exposure Time Delay ①	0.013	Delay time from trigger input rising to ExposureActive rising [μ s]
Exposure Time Delay ②	0.013	Delay time from trigger input falling to ExposureActive falling [μ s]
Actual Exposure Delay	14.26	Delay time from ExposureActive falling to completion of exposure inside the sensor [μ s]
Dataout Delay	39	Time from ExposureActive falling to FrameActive rising [H]

※ Please refer to the time for 1 line in [Section 3.5.1. Frame rate of Internal Trigger Sync. Mode](#) for time for 1H.

4.6.7 Restrictions on Trigger Pulse Input Timing

Please refer to the following restrictions for external trigger input timing. Error will occur if these restrictions are not met.

- (1) With TriggerSyncMode=ClockSync, user cannot input next trigger until completion of readout images. Input triggers after completed readout.

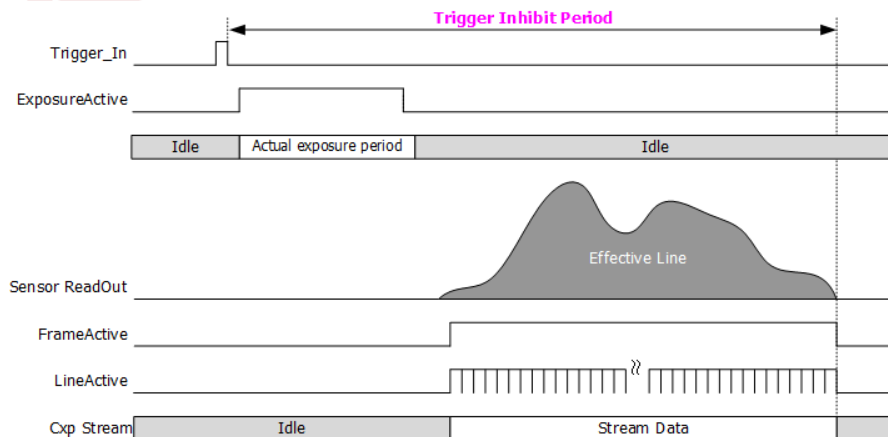

- (2) User can input the next trigger while reading out images with TriggerSyncMode=LineSync, However, end exposure before completion of readout is invalid. Make sure to end exposure after completion of readout, then start readout.

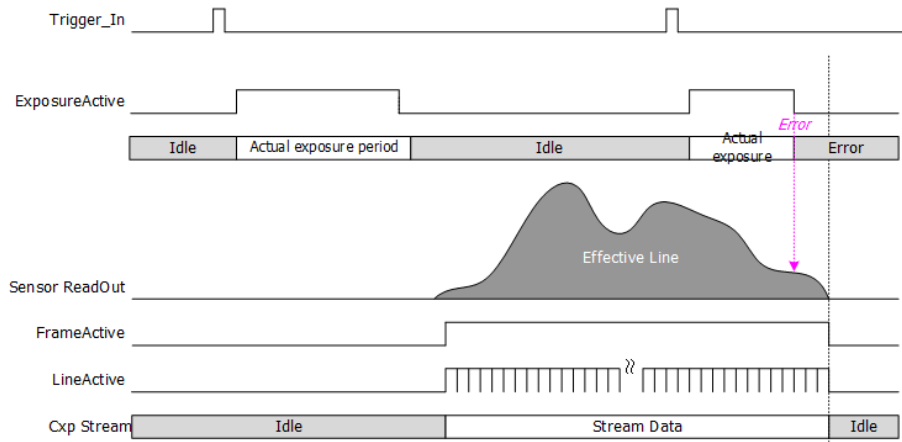

- (3) Do not input the next trigger during exposure period with TriggerSyncMode=LineSync and TriggerActivation=RisingEdge/FallingEdge.

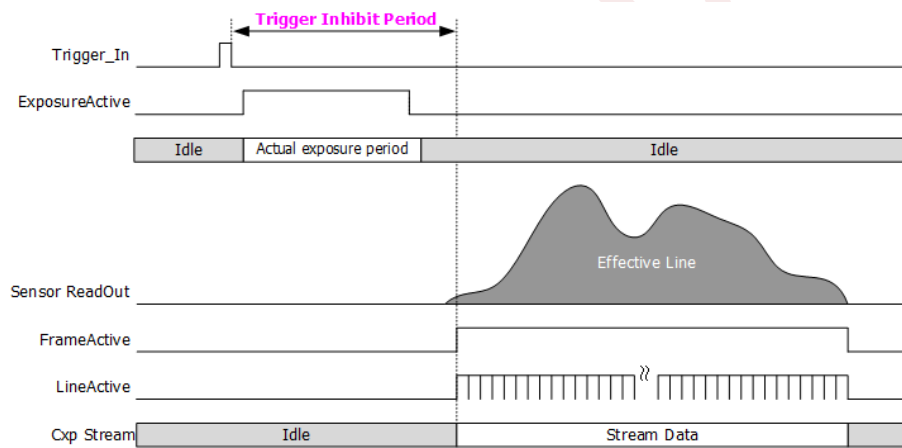

When there is an external trigger input during restricted period, camera LED emission status becomes error. User can check the error status with the following command as well.

Acquisition Control	
IllegalTriggerFlag	0 or 1 (ReadOnly)

- IllegalTriggerFlag: If there is a trigger input with restricted timing explained in the above, "IllegalTriggerFlag" becomes "1".

Device Control	
ErrorFlagReset	(Execute)

- ErrorFlagReset: This is to reset IllegalTriggerFlag to "0".

4.7 Exposure Time

Acquisition Control	
ExposureMode	Timed TriggerWidth
ExposureTime (us)	LineSync: 17us~ExposureTimeMax ClockSync: 15μs~200ms
ExposureTimeMax	(ReadOnly)

- ExposureMode : This is to check if current mode is Timed or TriggerWidth.
- ExposureTime : Set exposure time with us unit. Valid when ExposureMode is Timed.
 - Set per 1H when the trigger operation is H sync. It will return the value (us) rounded by 1H.
 - Set per approx. 1us when the trigger operation is CLK sync.
- ExposureTimeMax : Settable Max. exposure time (us).

4.7.1 Formula to Calculate Manual Shutter Values with H Sync Mode

ExposureTime will be rounded to the value corresponds to the following formula.

$$\text{Exposure time} = \text{Time for 1 line} \times \text{Exposure line count} + 14.26\mu\text{s}$$

- The Min. value for exposure line count is 1 line.
- The Max. value will be clipped with 1088 or with the total line count of partial mode.

4.8 Gain

AnalogControl	
Gain	1.00 ~ 256.00

- Gain: User can set gain value in the range of x1.00~x256.00. However, with high gain settings (x64.00 or more), noise will increase and image quality deteriorates. (With 8bit mode, image quality deteriorates with x16.00 or more gain due to x4 offset gain.)

4.9 Black Level Adjustment

AnalogControl	
BlackOffset	-64 ~ 63

- BlackOffset : This is not a function to set absolute value of black level.
User can adjust black level of image sensor proportionally.
This is a value converted by 12bit. The value will be equivalent to 1/4 of setting value with 10bit, and equivalent to 1/16 of setting value with 8bit.

4.10 Partial Scan (ROI)

- This is to increase frame rate by cutting and reducing read out area with vertical direction. When cutting and reducing read out area with horizontal direction, frame rate will not change.
- Please refer to [3.5. Frame Rate](#) for the frame rate corresponds to the cutting out image size.

ImageFormatControl	
RegionSelector	EffectiveRegion , Region0
RegionMode	On (Fixed)
RegionDestination	Stream0 (Fixed)
Width	640~1456 (Multiples of 4)
Height	4~1088 (Multiples of 4)
OffsetX	0~816 (Multiples of 4)
OffsetY	0~1084 (Multiples of 4)

- RegionSelector:
 - EffectiveRegion: This is to check Width and Height of the effective Region.
 - Region0: VCC-SXCXP5M is Region0 only.
 - ※ Make sure to select EffectiveRegion when acquire images.
 - ※ When there is no effective Region, user cannot select EffectiveRegion.
- RegionMode: Set valid/invalid of selected Region. With this model VCC-SXCXP5M, RegionMode is always valid (On).
- RegionDestination: Select Stream to output. VCC-SXCXP5M is fixed to Stream0.
- Width: Width of Region. Set with multiples of 4.
- Height: Height of Region. Set with multiples of 4.
- OffsetX: Offset for X direction of Region. Set with multiples of 4.
- OffsetY: Offset for Y direction of Region. Set with multiples of 4.
 - ※ Set Width, OffsetX, Height, and OffsetY to satisfy the following conditions.
 - $640 \leq \text{OffsetX} + \text{Width} \leq 1456$
 - $4 \leq \text{OffsetY} + \text{Height} \leq 1088$
- ※ When changed partial scan settings, disturbance images may occur for 8 frames after changed settings. In this case, input dummy trigger for 8 times with external trigger mode, then use from 9th trigger as an actual trigger signal.

4.11 Defective Pixel Correction

- This is a function to detect and correct defective pixels in output data from the sensor.
- There are two types of defective pixel data.
 - Defective data registered at factory
Black and white defective pixel data registered upon shipment from our factory. These data cannot be over-written.
 - Defective data registered by user
Data registered by user. In addition to the correction of defective pixel data registered upon shipment, we provide a method to update the defective pixel data. With DefectPixelDefault command, user can delete these user-registered data.
- Camera keeps defective pixel correction information with normal mode and with vertical flip separately. (The position and number of defective pixel are different between with normal mode and vertical flip mode.)
- User can register up to 128 points. (Note: Up to 32 points per CH.)

[CH (Channel)] Camera performs image processing with 4CH interleave.

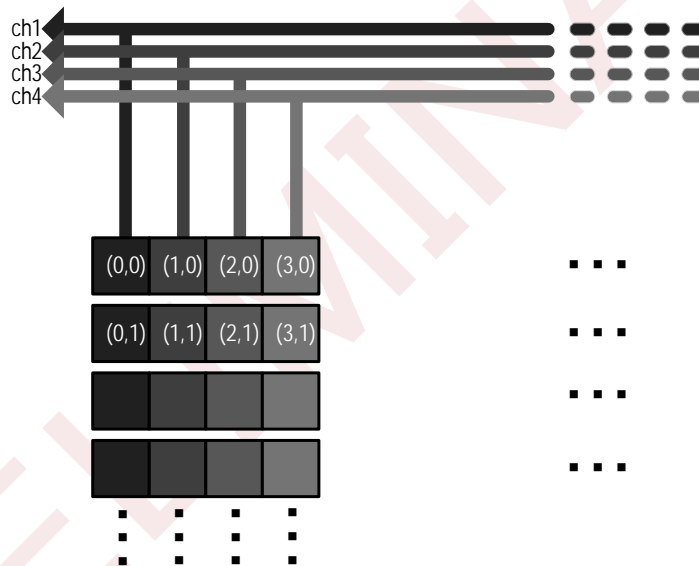

- How to control defective pixel correction

AnalogControl	
DefectPixelCorrection	On/Off

- DefectPixelCorrection: This is to turn On/Off defective pixel correction processing.
- ※ Defective pixel correction data at factory and defective pixel correction data registered by user will be both controlled at the same time.

- Defective data registered by user

This is to add/delete the designated X and Y coordinate.

AnalogControl	
DefectPixelAdd	(Execute)
DefectPixelAddOffsetY	0~1087
DefectPixelAddOffsetX	0~1455
DefectPixelDelete	(Execute)

- DefectPixelAdd: This is to register the designated coordinate as defective pixel correction point.
- DefectPixelAddOffsetY: Designate Y coordinate to register.
- DefectPixelAddOffsetX: Designate X coordinate to register.
- DefectPixelDelete: This is to delete the designated coordinate registered as defective pixel correction point.

※ Only the defects registered by user can be deleted. If the coordinate same as defective data at factory is designated, it will be ignored.

※ Make sure to execute UserSetSave to save data into camera non-volatile memory. (Not saved in camera non-volatile memory at the time of registration with DefectPixelAdd command.)

※ User cannot execute DefectPixelAdd and DefectPixelDelete when DefectDetectionStatus is error (0x000e0001 and 0x000e0002). Execute DefectPixelDefault, or execute DefectDetection to remove error with DefectCorrectMode = Reacquire and execute DefectPixelAdd and DefectPixelDelete again.

※ Defective pixel correction function calculates value for X pixel referring to peripheral pixels (up and down, left and right). When all peripheral pixels, X1, X2, X3, and X4, are already registered as defective pixels, user cannot correct the X pixel.



Defective pixel detection registered by user

This is to detect and register data of white defect caused by image sensor.

Make sure to shield light from image sensor to acquire images and detect defects.

AnalogControl	
DefectDetectionThresholdValue	0~4095
DefectDetection	(Execute)
DefectDetectionStatus	(ReadOnly)
DefectCorrectMode	Reacquire/Add

- DefectDetectionThresholdValue:

This is to set a threshold value (12bit equivalent) for user defective pixel detection. Data which exceeds the signal level designated here will be registered. With 8bit images, designate a value of 16 times of signal level as a threshold value.

- DefectDetection:

This is to execute defective pixel detection. If it executed normally, the detection result coordinate will be registered .

※ Make sure to execute UserSetSave to save data into camera non-volatile memory. (Not saved in camera non-volatile memory at the time of registration with DefectDetection command.)

※ Make sure to execute this command while grabbing (acquiring images).

※ Make sure to execute with full frame (1456×1088).

- DefectDetectionStatus: This is to indicate results of defective pixel detection.

0	No defective pixel correction data registered by user.
Value (128 or less)	The number of detected defective pixels registered by user.
0x000e0001 (917505)	Total number of defective pixel correction data exceeds the maximum number to register in one CH. (32)
0x000e0002 (917506)	Total number of defective pixel correction data exceeds the maximum number to register. (128 points)

※ When the value 129 or more is indicated, check if user threshold value (DefectDetectionThresholdValue) or the conditions of environment and camera settings are appropriate.

※ Please note that the value may be indicated in decimal depends on the grabber board to use.

- DefectCorrectMode: This is to select detection mode of defective pixels out of the followings.

Reacquire: This mode deletes defective pixel data except those added by designating coordinate and reacquire defective pixels.

Add: This mode acquires defective pixels in addition to the current pixels registered.

[Note]

Maximum number of defective pixels to register and to correct may not always be the same due to following reasons.

(1) With white defects detection, if one of interleave channel reaches the maximum number of defective pixels to register, correction stops. Function registers data up to that point, outputs error, and ends operation.

(2) When there is no effective pixel around the pixel to add (on the left, right, top, and bottom), user can register but cannot correct that pixel.

User cannot execute DefectDetection when the camera is set to DefectCorrectMode = Add and DefectDetectionStatus is error (0x000e0001 and 0x000e0002).

Execute it after executed DefectPixelDefault, or when the camera is set to DeffectCorrectMode = Reacquire.

- Entire deletion of data registered by user

User can delete entire data (data registered by designating coordinate and by defect detection) with the following command.

AnalogControl	
DefectPixelDefault	(Execute)

※ Camera keeps defective pixel information with vertical flip ON/OFF in separate table. With DefectPixelDefault, camera deletes only the user registered defective pixel information of the table in use. When vertical flip is ON, camera deletes user registered defective pixel information entirely with DefectPixelDefault. When vertical flip is OFF, camera does not delete user registered defective pixel information.

□ Indication of defective pixel data

This is to indicate the information of defective pixels registered at factory and by user.

AnalogControl	
RegisteredDefectSelector	UserState/InitialState
DefectPixelNumber	1~128/1~384
DefectPixelOffsetY	(ReadOnly)
DefectPixelOffsetX	(ReadOnly)
DefectPixelType	(ReadOnly)
ChannelNumber	1~4
DefectPixelChannelCount	(ReadOnly)

- ♦ RegisteredDefectSelector: This is to select the types of registered defects.
 - UserState: Data registered by user
 - InitialState: Data registered at factory
- ♦ DefectPixelNumber: This is to designate a table number of the defective data registered at factory and by user.
- ♦ DefectPixelOffsetY: This is to indicate Y coordinate of the defective pixel designated with DefectPixelNumber. When user designated a table number with no defective pixel data, it shows 65535.
- ♦ DefectPixelOffsetX: This is to indicate X coordinate of the defective pixel designated with DefectPixelNumber. When user designated a table number with no defective pixel data, it shows 65535.
- ♦ DefectPixelType: This is to indicate the types of defects designated with DefectPixelNumber.
 - 1: White defects registered upon shipment from factory
 - 2: Black defects registered upon shipment from factory
 - 6: Defects registered by user (Defective pixel detection)
 - 7: Defects registered by user (Designating coordinates)
 - 65535: Table without defects

User can indicate the number of defective pixels registered for each channel with following command.

- ♦ ChannelNumber: This is to designate channel number of defective pixel correction.
- ♦ DefectPixelChannelCount: This is to indicate defective pixel count for the channel designated with ChannelNumber.
(This is the sum total of defective pixel with factory count and user register count.)

4.12 Test Pattern Indication

This is to display test pattern from camera. This is useful to check if your system is operating properly.

ImageFormatControl	
TestPattern	Off GrayHorizontalRamp GrayHorizontalRampMoving

※ Displaying test pattern and cursor are mutually exclusive.

4.13 Cursor Indication

This is to show cursor on your display screen.

ImageFormatControl	
CursorPattern	Off/On
CursorOffsetX	0 ~ 1455
CursorOffsetY	0 ~ 1087
CursorColor	White/Black

※ Displaying test pattern and cursor are mutually exclusive.

- CursorPattern: Cursor indication On/Off.
- CursorOffsetX: X coordinate of vertical cursor.
- CursorOffsetY: Y coordinate of horizontal cursor.
- CursorColor: This is to select the color of cursor (black or white).

[Note]

- With partial (ROI) indication, the top left of the active area will be the origin coordinate (0,0) for the coordinate of the cursor.
- Cursor may not be indicated when reduced the size of indicated image.

4.14 LED Operational Mode

This is to change operational mode of LED at the rear of camera. For information on lighting patterns, refer to [Section 3.3.3. LED Indicator](#).

DeviceControl	
DeviceIndicatorMode	Active ErrorStatus Inactive

Active: Indication of communication status of CoaXPress.

ErrorStatus: OFF with normal operation. Lights only with system error.

Inactive: ALL LED OFF

4.15 Camera Timing I/O

Camera indicates/selects the functions through pin No. 3 and 5 of 6pins circular connector.

Digital IO Control	
LineSelector	Line0 Line1
LineMode	Input / Output (ReadOnly)
LineSource	[With Line0] FrameTrigger (Fixed) [With Line1] OFF ExposureActive FrameActive LineActive TriggerPacketActive

- LineSelector: Select line to set/select.
Line0: No.5 pin of 6pins circular connector
Line1: No.3 pin of 6pins circular connector
- LineMode: Indicate the I/O direction of the selected line.

- LineSource: Select signal out of followings for the selected line.
 - FrameTrigger: Input trigger to the camera. (Dedicated to Line0.)
 - ExposureActive: Indicate exposure period of image sensor with Hi active.
 - FrameActive: Indicate effective period of frame with Hi active.
 - LineActive: Indicate effective period of line with Hi active.
 - TriggerPacketActive: Decode and output packet signals of uplink trigger from frame grabber.

4.16 User ID

DeviceControl	
DeviceUserID	Manual
DeviceUserString	Manual

- DeviceUserID: Set a letter string as DeviceUserID with up to 16 characters including terminal NUL letter (\0).
 - DeviceUserString: Set a letter string as DeviceUserString with up to 256 characters including terminal NUL letter (\0).
- Execute UserSetSave to save these letter strings to camera non-volatile memory.
 These data are not subject to "UserSetLoad" with "Default."

4.17 Temperature Indication

This is to indicate temperature of image sensor (°C).

DeviceControl	
DeviceTemperatureSelector	Sensor (Fixed)
DeviceTemperature	(ReadOnly)

- DeviceTemperatureSelector: This is to select the point of the device to measure temperature. Fixed with sensor for VCC-SXCXP5M.
 - DeviceTemperature: This is to indicate the image sensor temperature of selected point.
- ※ This is a reference temperature and not the actual temperature.

4.18 Connection Reset

When troubles occurred with CXP connection, user can reset the device with the following command.

Transfer Control	
ConnectionReset	1(Execute)

- ConnectionReset: Reset the device and reconnect it automatically.
 - ※ Please note that it takes few seconds to reconnect the device.
 - ※ Until completed reconnecting the device, error might be indicated temporary with DeviceTemperature, IllegalTriggerFlag etc. Reacquire the values after completed reconnection.

4.19 Gamma Correction

AnalogControl	
Gamma	0.10~1.80 coefficient

- ◆ Gamma : This is to set gamma correction value per 0.01 step from 0.10 to 1.80.

[Note]

Camera updates gamma table at the timing of image output.

With continuous operation mode, camera applies the updated gamma table at the timing of image output after completion of rewriting gamma table (approx. 20ms: refer to Command ACK as a rough guide).

If user changes gamma coefficient while waiting for a trigger input, camera outputs images with updated gamma table with a trigger after completion of rewriting gamma table.

4.20 Image Quality Selection Mode

This is a function to select image quality of output images.

AnalogControl	
ImageQualityMode	StandardMode LowFrameRateMode

- ◆ Image Quality Mode: Image quality selection mode

- ◆ StandardMode: Standard mode

- ◆ LowFrameRateMode: This mode improves S/N compared to standard mode.

However, frame rate and sensitivity decrease. Frame rate will be the same value as 10bit. Enabled only when PixelFormat is Mono8. With Mono10/12, mode will become StandardMode.

4.21 Shading Correction

- This is a function to correct the drop in the amount of peripheral light caused by lens and others.

AnalogControl	
ShadingCorrectionDataSelector	Off/Table1/Table2/Table3
DetectShading	(Execute)

- ◆ ShadingCorrectionDataSelector : This is to select shading correction data and select where to save the detected correction data.

Off: Disable shading correction.

Table1- 3: Enable shading correction with the selected correction value. Select Table from 1-3 and execute DetectShading to acquire correction data to the specified Table.

Before shading correction

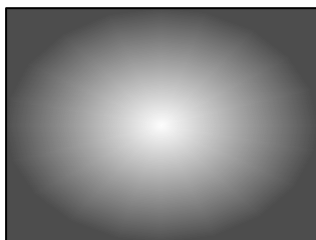

After shading correction



- DetectShading:

Shoot an object with stable brightness such as pattern box to full screen to execute DetectShading. Function automatically calculates shading correction data and saves the calculated correction data in the selected table with ShadingCorrectionDataSelector.

[Note]

- Make sure to set full frame (1456x1088) to execute shading detection.
- Acquire correction data when the camera is in operation.
(When the camera does not output anything, user cannot acquire shading correction data.)
- Execute UserSetSave to save the correction data of Table1~Table3 into non-volatile memory at the same time.
- Even execute Default with UserSetLoad, camera maintains correction data.
- User cannot execute shading detection when ShadingCorrectionDataSelector is Off.

PRELIMINARY

5 Factory Settings

Function	Data	Explanation
TriggerSelector	AcquisitionStart	Internal sync. mode (Free run)
TriggerMode	Off	Internal sync. mode (Free run)
TriggerSyncMode	LineSync	H sync. mode
TriggerSource	LinkTrigger0	CXP UpLink trigger
TriggerActivation	RisingEdge	Rising edge
ExposureTime	3502	Exposure time 3502 μ s
Gain	1.00	Gain x1.00
Gamma	1.00	Gamma correction value 1.00
BlackOffset	0.0	Initial value of black level
DefectPixelCorrection	On	Defective pixel correction On
DefectPixelAddOffsetX	0	X coordinate of defective pixel correction
DefectPixelAddOffsetY	0	Y coordinate of defective pixel correction
DefectDetectionThresholdValue	200	Threshold value of defective pixel detection
PixelFormat	Mono8	Monochrome 8bit
ConnectionConfig	CXP6_X1	CXP-6(6.25Gbps), 1 link
ImageQualityMode	Standard	Image quality mode (Standard)
TestMode	NomalOperation	Normal mode (= Link test mode Off)
RegionSelector	EffectiveRegion	Partial area (ROI) Region0 Effective status
RegionMode	On	Partial area (ROI) On
Width	1456	Partial area (ROI) Horizontal 1456 pixels (with full size)
Height	1088	Partial area (ROI) Vertical 1088 lines (with full size)
OffsetX	0	Partial area (ROI) Horizontal starting position 0
OffsetY	0	Partial area (ROI) Vertical starting position 0
ReverseX	FALSE	Horizontal flip OFF
ReverseY	FALSE	Vertical flip OFF
TestPattern	Off	Test pattern indication Off
CursorPattern	Off	Cursor indication Off
CursorOffsetX	728	Vertical cursor X coordinate = 728
CursorOffsetY	544	Horizontal cursor Y coordinate = 544
CursorColor	White	Cursor color = White
DeviceIndicatorMode	Active	CoaXPress connection status indication mode
LineSelector	Line0	Line0
LineSource	FrameTrigger	Trigger input
DeviceUserID		User set letter string (16 letters)
DeviceUserString		User set letter string (256 letters)

※ ConnectionConfig, PixelFormat, and ImageQualityMode are not subject to UserSetLoad.

6 Dimensions

6.1 Camera Dimensions

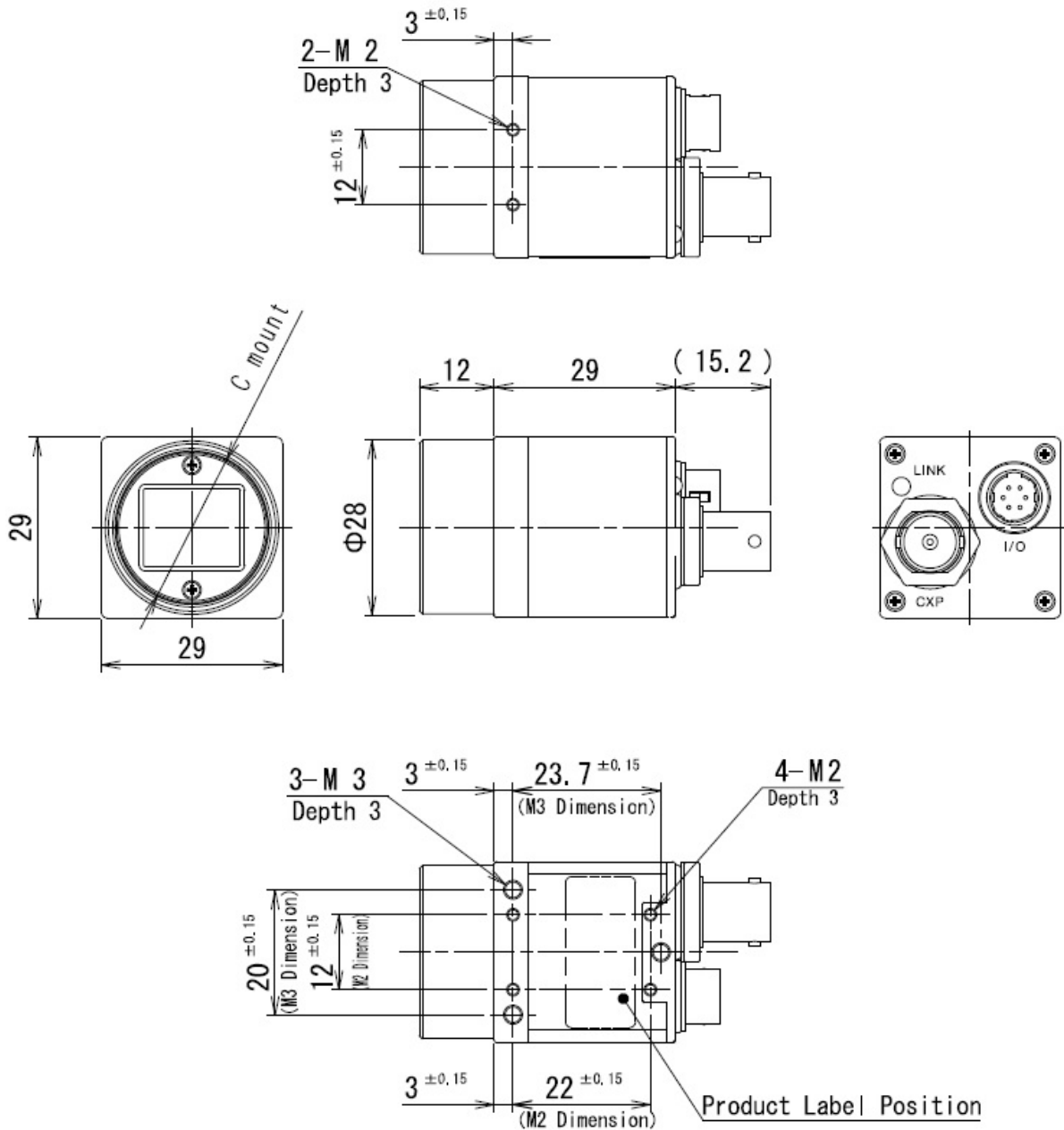

Note 2) C mount screws comply with ANSI/ASME B1.1, 1-32UN (2B).

Note 1) Screw length from the lens mount surface shall be less than 6 mm. And protruding portion of the C mount lens shall be less than 10 mm.

935-0178-00

(Unit: mm)

6.2 Optical Axis Accuracy

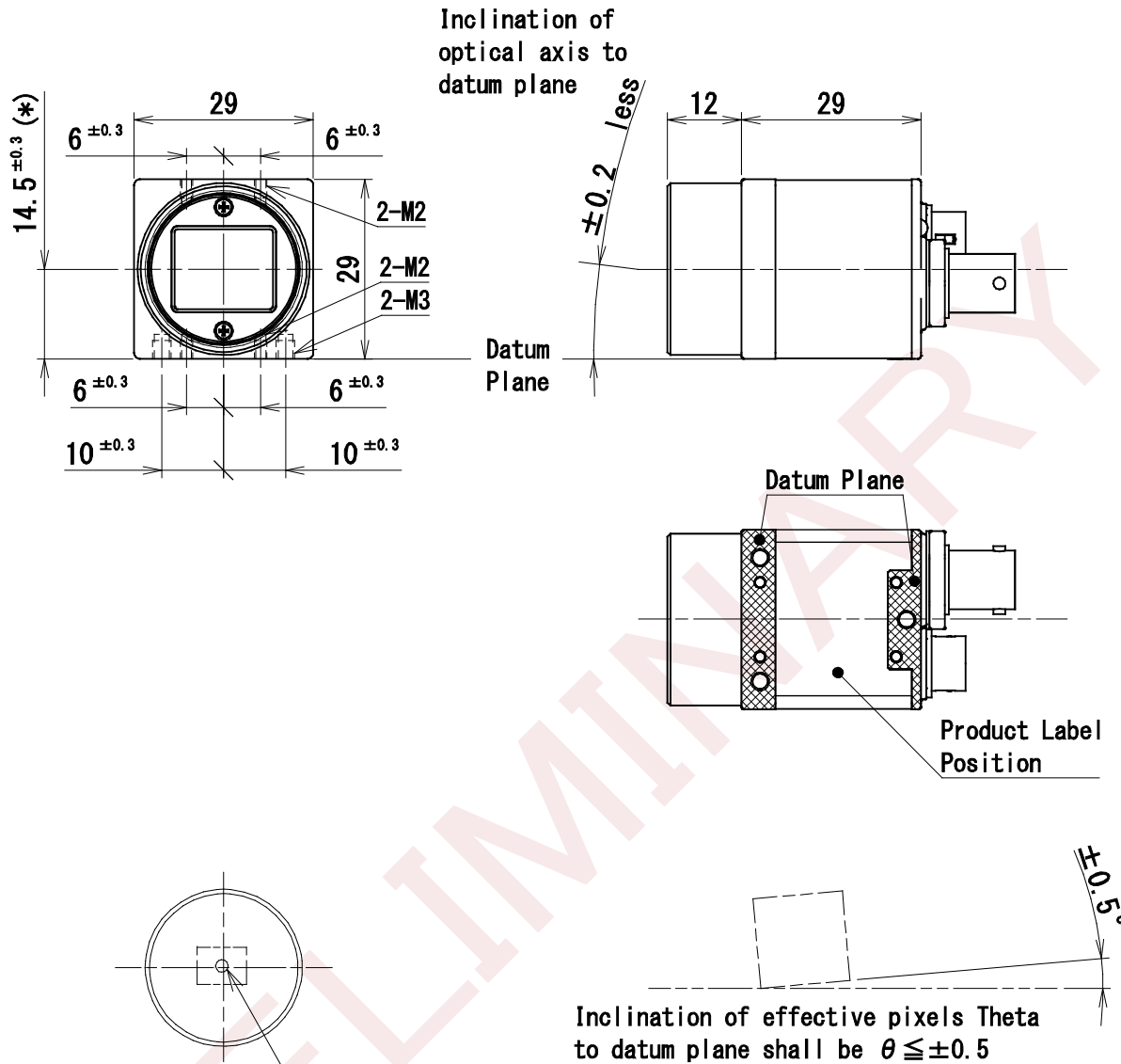

The center of effective pixels shall be within $\Phi 0.6$ to the center of lens mount.

(*Dimension from datum plane to the center of lens mount.

937-0014-00
(Unit:mm)

7 Case for Indemnity (Limited Warranty)

7.1 Product Warranty

The term of warranty of this product is within 3 years from the date of shipping out from our factory.

If you use the product properly and discover a defect during the warranty period, and if that was caused by designing or manufacturing, CIS Corporation, at its option, repairs or replaces it at no charge to you. Products out of warranty period will be subject to charge.

CIS should not hold responsible for damages or losses if;

- damages or losses are caused by earthquake, lightning strike, fire, flood or other acts of God.
- damages or losses are caused by deliberate or accidental misuse by user, or failure to observe the information contained in the instructions in this Product Specification and Operational Manual.
- damages or losses are caused by repair or modification conducted by customer or any unauthorized party.

7.2 CMOS Defective Pixels

CIS applies defective pixel correction prior to shipment of the product. However, the number of defective pixels are subject to increase due primarily to the effect of cosmic rays. Due to this nature, CIS should not hold responsible for the natural increase of defective pixels.

7.3 Product Support

Should you have any problems in function of the product you purchased, and if you need our further analysis and/or repair, please contact your local distributor.