

This information is brought to you by:



**ELECTRONIC GROUP, INC**  
480-635-8400 p \* aegis-g2@aegiselect.com  
<http://www.aegis-elec.com>

# SDI-EV 3G HDSDI interface board for SONY FCB HD cameras

Technical manual

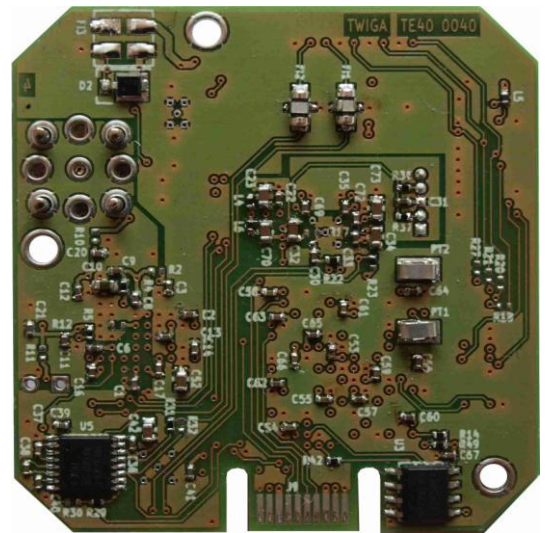
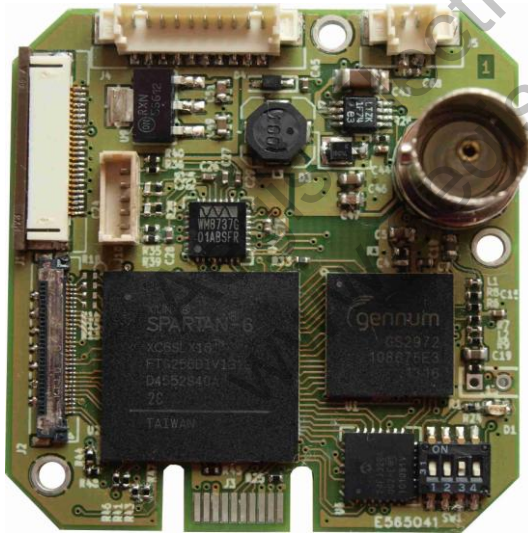

## **Revision History**

<b>Date</b>	<b>Modifications</b>	<b>Pages</b>
Oct, 9th, 2013	Original	All

Aegis Electronic Group  
www.aegiselect.com

# 1 Board description

This board provides a 3G HDSDI output for FCB EV SONY cameras.

In option, two audio inputs with microphone or line level are available.

Depending on camera model, component and SD composite analog video outputs are also available.

Camera video standard is coded with switches and a serial link (RS232 or TTL level) allows control of camera and audio setting.

## 1.1 Block diagram

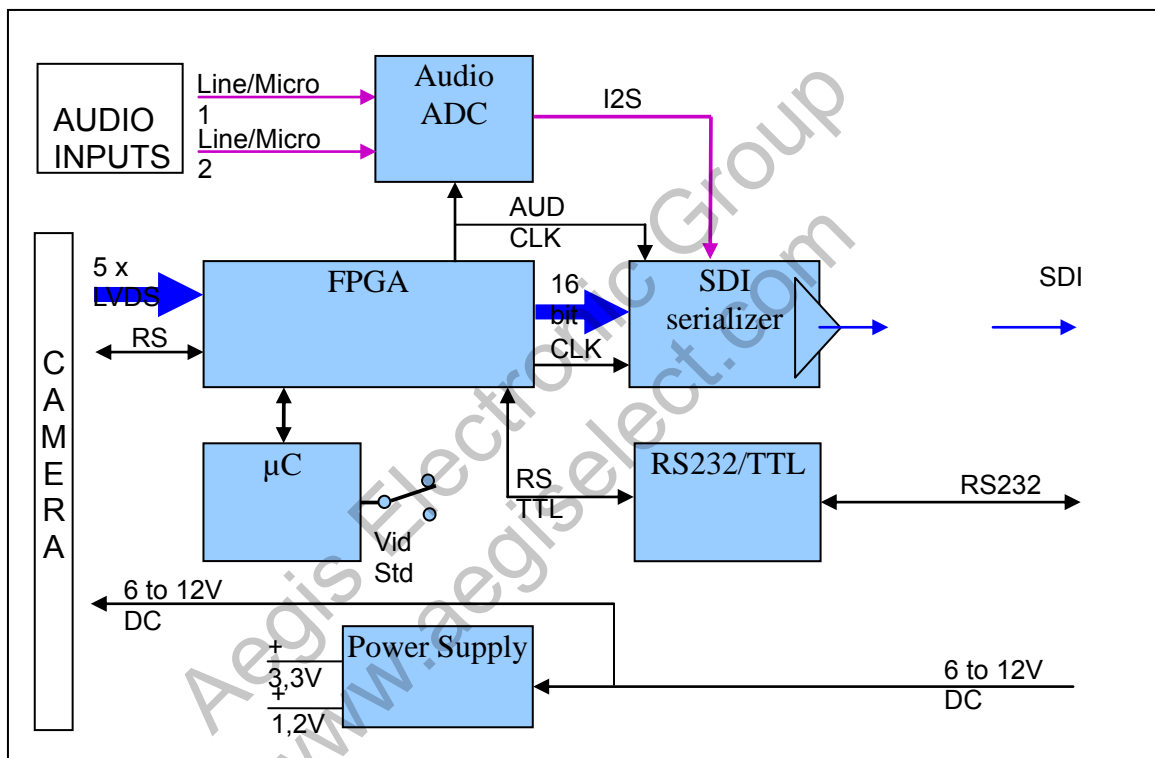

Features :

- LVDS decoding to 16 bit parallel BT656 video bus (FPGA)
- (In Option Audio inputs selection, amplification and analog to digital conversion according I2S format (audio ADC))
- Video and audio multiplexing, serialization and SDI signal generation (SDI serializer)
- At power on, reading of camera video standard and configuration according to DIP switches (RS232 VISCA protocol)
- RS232 to/from TTL conversion for external control
- 6 to 12V DC camera power supply and 1.2V and 3.3V voltage generation

## 1.2 Technical Characteristics

### 1.2.1 LVDS Video Input

- 4 pairs data LVDS signals and 1 pair clock signal (74,25MHz)
- Y Cb/Cr 8 bit coding + HVF synchros
- Video formats : 1080p59,97/50, 1080P29.94/25, 1080i50/60, 720p 50/60, 1080p25/30, 720p25/30 according to camera model
- KEL USL30 pin connector

### 1.2.2 Analog audio inputs ( option)

- Two audio channels : Line or microphone level (RS control)
- Line input (47k ohm impedance) :
  - 0 dBu analog input level for -18dBFS SDI level
  - gain setting from -97dB to + 30dB
- Microphone input :
  - DC bias voltage up to 2.3V for electret microphones
  - maximal gain :+63dB
- Fonctions (RS control) : Constant recording volume - Automatic level control (ALC), 2 channels mixing
- 24bit, 48kHz analog to digital conversion
- Frequency response : 20Hz – 20kHz +/- x.xdB
- Noise: -xxxdB
- Molex 1.25mm 5 pin connector

### 1.2.3 HDSDI video output

- 8 bit SDI signal 800mV pp, 75 ohm impedance compliant to SMPTE 424M and 292M
- Same video format as camera
- Rate : HD = 2.970 Gb/s & 1.485Gb/s.
- Option 2 audio channels embedded on group 1 (SDI)
- BNC, SMB or MCX 75 ohm connector

### 1.2.4 Analog video output

- YPbPr and CVBS according to camera
- Molex 1.25mm 10 pin connector

### 1.2.5 Serial control

- TTL (3V3) or RS232 level
- Molex 1.25mm 10 pin connector

### 1.2.6 Miscellaneous

- 6 to 12V DC power supply, about 5W consumption with camera
- Board dimensions : 45mm x 48mm, 3 mounting holes diam. 2.5mm

## 2 Connections

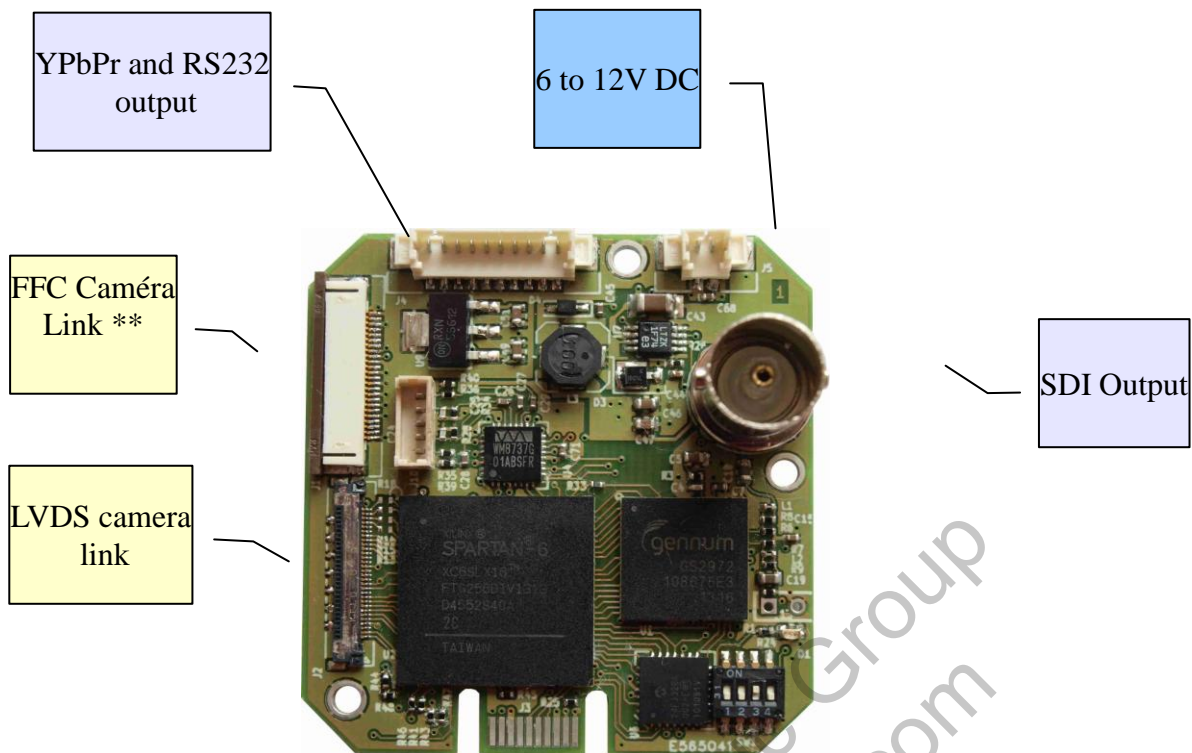

### 2.1.1 Connection to camera

- LVSDS cable : 30 microcoaxial harness KEL ref USL20-30SS-xxx-C
- FFC cable : 0.5mm FFC 24 ways

\*\* FFC link is optional as KEL cable contains LVDS video signals, serial control and power supply

## 2.2 **Connectors pinout**

### 2.2.1 Power supply (J5)

+V	0V
1	2

MOLEX 53398-0271 connector

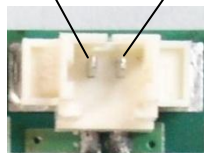

## 2.2.2 Camera FFC (J1)

MOLEX 53398-0271 connector

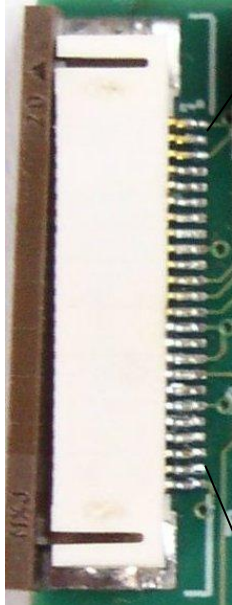

1	0V-GND
2	+V
3	0V-GND
4	+V
5	+V
6	+V
7	+V
8	0V-GND
9	Pr
10	0V-GND
11	Pb
12	0V-GND
13	Y
14	0V-GND
15	CVBS
16	0V-GND
17	NC
18	0V-GND
19	NC
20	0V-GND
21	NC (Reset In camera)
22	RxD (Camera TTL input )
23	TxD (Camera TTL output)
24	0V-GND

## 2.2.3 Video analog outputs (J4)

MOLEX 53398-1071 connector

Y	Gnd	Pb	Gnd	Pr	Gnd	TxD	RxD	Gnd	NC
1	2	3	4	5	6	7	8	9	10

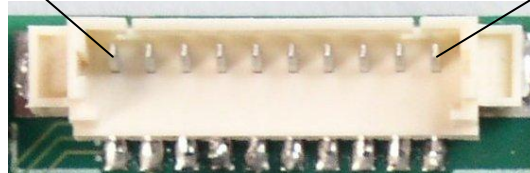

TxD : Board output

RxD : Board input

RS232 or TTL level according resistors configuration

## 2.2.4 Camera LVDS (J2)

KEL USL00-30L connector



	FCB_EH	FCB_SE600
30	TX4-	
29	TX4+	
28	TX5-	
27	TX5+	
26	NC (Camera RESET)	NC (Camera RESET)
25	NC	NC
24	TX6-	0V-GND
23	TX6+	0V-GND
22	TX7-	0V-GND
21	TX7+	0V-GND
20	0V-GND	0V-GND
19	0V-GND	0V-GND
18	+6V à 12V	+5V
17	+6V à 12V	+5V
16	+6V à 12V	+5V
15	+6V à 12V	+5V
14	+6V à 12V	+5V
13	RxD (Camera TTL Input)	RxD (Camera TTL Input)
12	TxD (Camera TTL Output)	TxD (Camera TTL Output)
11	0V-GND	0V-GND
10	TX0-	TX0-
9	TX0+	TX0+
8	TX1-	TX1-
7	TX1+	TX1+
6	TX2-	TX2-
5	TX2+	TX2+
4	TXCLKOUT-	TXCLKOUT-
3	TXCLKOUT+	TXCLKOUT+
2	TX3-	TX3-
1	TX3+	TX3+

## 2.2.5 AUDIO (J10)

Option : Ask for information

## 3 Signalization and configuration

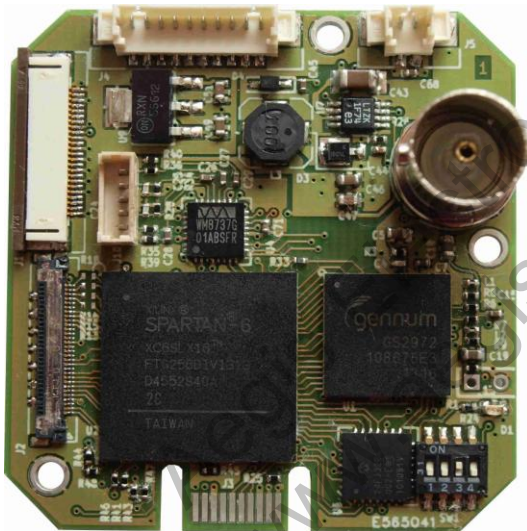

### 3.1 **Signalization LED**

Periodically blinking led . Number of flashes indicates different states of the board :

- 1 flash every 2 seconds : starting
- 2 flashes every 2 seconds : FPGA loading OK
- 3 flashes every 2 seconds : VISCA link with camera OK
- 4 flashes every 2 seconds : camera identification and video format configuration OK
- 5 flashes every 2 seconds : audio ADC configuration OK
- 6 flashes every 2 seconds : video FPGA configuration OK

### 3.2 RS232 Resistors , R29 to R32

These 4 resistors select the serial link voltage level :

#### RS232 voltage level

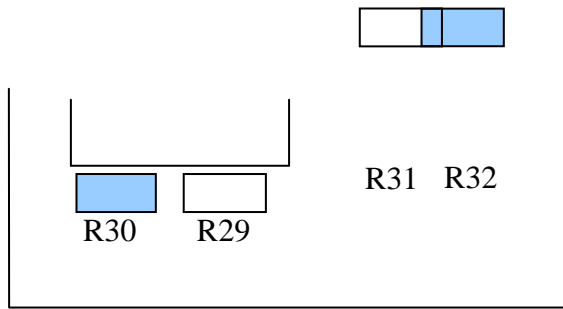

- RS232 voltage level on external side, TTL on camera side

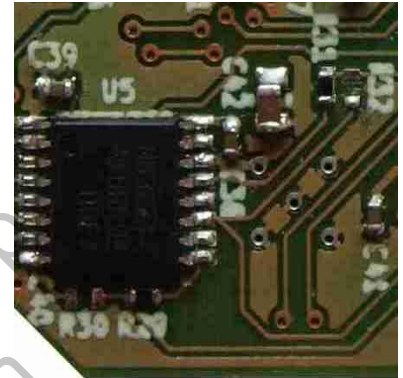

•

R29 et R31 soldered

---

#### TTL voltage level (+3V3, +5V tolerant) on external side

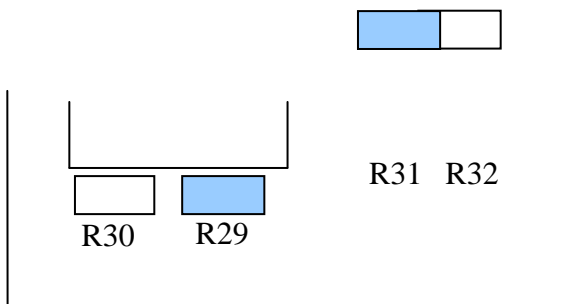

R30 et R32 soldered