



A wide range of sensitivity from visible light to 1700nm
SONY IMX990, IMX991 adopted SWIR camera

NEW

A wide-band and high-sensitivity SWIR camera

GiGE
VISION

USB
VISION

CAMERA
Link

SenSWIR



- Interface
 - GigE Vision
 - USB 3 Vision
 - Camera Link
- 0.3M (640x512)
- 1.3M (1280x1024)
- Lens Mount: C-mount
- Peltier cooling supported

Feature

Sony's SenSWIR image sensor adopted wide-sensitivity SWIR camera with the addition of OMRON SENTECH's heat dissipation design

Adoption of IMX990, 991

IMX990 1/2-inch type (8.2 mm diagonal) approx. 1.34 effective megapixel SWIR image sensor
IMX991 1/4-inch type (4.1 mm diagonal) approx. 0.34 effective megapixel SWIR image sensor

About SenSWIR

SenSWIR

A wide-band and high-sensitivity SWIR image sensor technology implemented by the combination of compound semiconductor InGaAs photodiodes and Si readout circuits through Cu-Cu bonding

Two functions in one camera

The camera with SenSWIR technology is compatible both with the SWIR spectrum and a wide band of 400 to 1,700 nm wavelengths, which includes the visible light spectrum. Inspections that previously required two cameras, one for visible light imaging and the other for SWIR, can now be carried out with one that integrates both functions. This not only widens the scope of items and purposes of inspection, but also helps to reduce system cost and accelerate image processing, improving throughput. Also, one camera means the captured images in two modes are identical to the pixel level, avoiding image shift

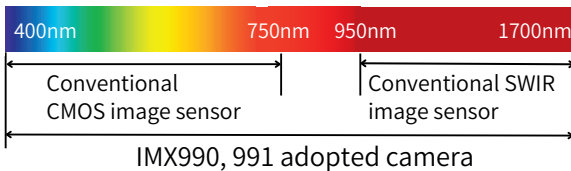

IMX990, IMX991

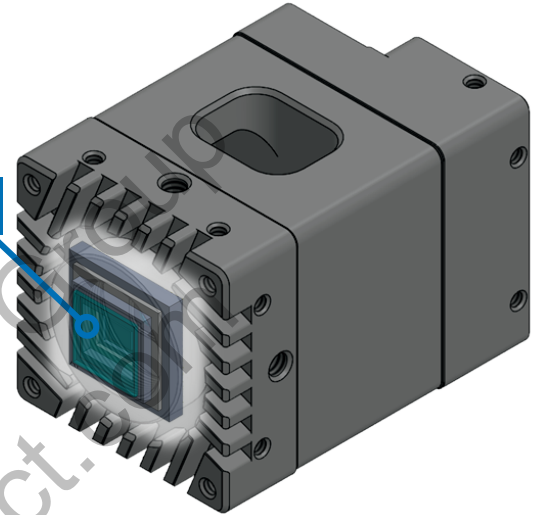

Taking image wavelength from 400nm to 1,700nm is available with just one camera unit!

Pride for Monozukuri
(making)

OMRON SENTECH develops and manufactures cameras with pride in order to provide cameras that customers can choose with confidence and continue to use

GiGE VISION **USB** VISION **Link** CAMERA

Selectable interface

The required interface will vary depending on the concept and purpose of the device. Sometimes frame rate, sometimes stability, long-distance transfer, etc. OMRON SENTECH's SWIR cameras are available in three types of interfaces and are proposed according to customer needs.

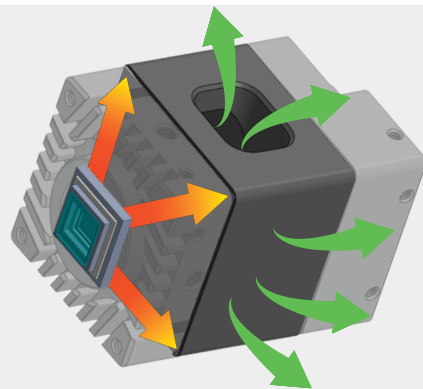

Discerning heat insulation design

Patent pending

The OMRON SENTECH camera has a special heat dissipation design so that it can operate stably even with natural cooling using the heat dissipation of the individual camera without using air cooling or water cooling.

The special heat sink at the tip of the camera prevents heat from being trapped and helps to dissipate heat efficiently, and the heat dissipation block in the center of the individual camera has a mechanism to evenly dissipate heat from the element.

*The note of <patent pending / patented> indicates that the patent is pending or patented in Japan. (As of May 2022)



Integrated thermoelectric cooling element adopted

If the internal temperature of the camera rises, the image quality will deteriorate and cause noise problems. IMX990 and IMX991 adopted cameras with a thermoelectric cooling element to improve image quality and reduce noise problems by performing more efficient heat dissipation.

Application

It makes possible to perform stable inspections that were difficult with visible light cameras by combining the sensitivity characteristics of IMX990 and IMX991 sensors with the external illumination (wavelength)



Emphasis Transparency

It is possible to emphasize what you want to see in the inspection or let the unwanted object transmit by selecting the wavelength of the external illumination which is fit for objects

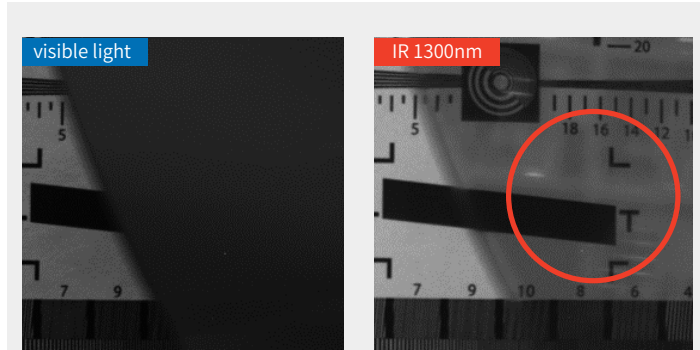

Wafer transmission inspection

Inspecting wafer defects and contamination by passing through the wafer

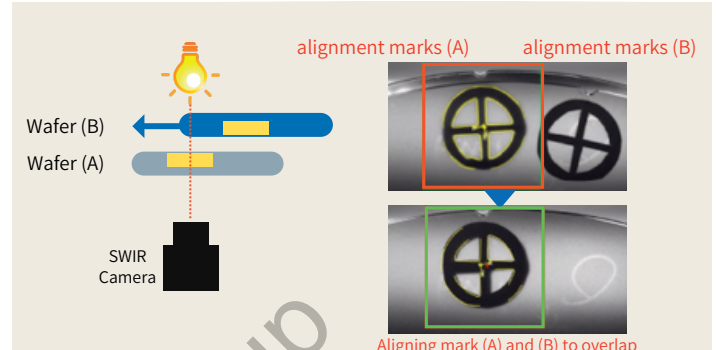

Wafer alignment

Positioning while directly checking alignment marks
Move the wafer (B) against the alignment mark () of the wafer (A) after transmitting the wafer



Content inspection of the package bag

Inspecting chipping and cracking contents by penetrating package

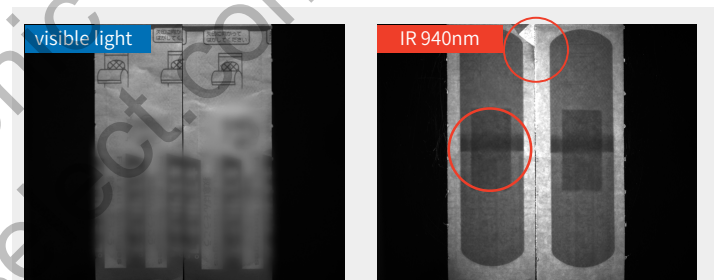

Content inspection of the packing paper

Inspecting packages for breakage, presence of contents and foreign objects by penetrating package



Internal inspection of the air fresheners

Inspecting condition of the filter paper in the liquid by transmitting white turbid liquid using transmission wavelength of liquid



Liquid inspection

stable inspection of transparent liquid volume and liquid leakage by emphasizing the absorption wavelength of the liquid

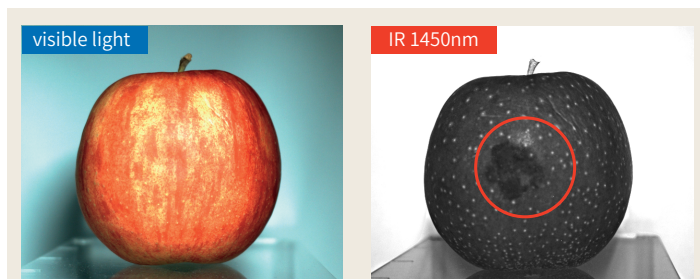

Fruit and vegetable sorting

Inspecting freshness and damaged part of fruits and vegetables that cannot be seen from the appearance

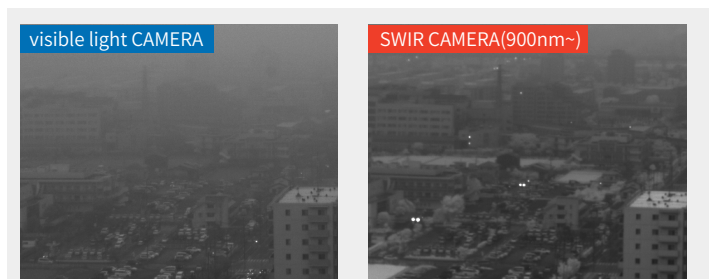

Nature observation & Surveillance

Less affected by fine particles in the atmosphere and reducing the effects of fog, clouds, smoke, etc., due to the longer wavelength than visible light

Specifications

Model	0.3M	STC-LBS34POE-SWIR
	1.3M	STC-LBS132POE-SWIR
Image Sensor	0.3M	1/4" 0.3M Progressive SWIR CMOS (IMX991)
	1.3M	1/2" 1.3M Progressive SWIR CMOS (IMX990)
Shutter mode	Global Shutter	
Effective Pixels	0.3M	656 x 520 (0.3M)
	1.3M	1,280 x 1,024 (1.3M)
Cell size	5.0(H) x 5.0(V) um	
Scan mode	Full scan/ ROI	
Maximum FPS	0.3M	242,2fps(8bit), 167.8fps(10bit) 223.7fps(10bit Packed), 42fps(12bit), 56fps(12bit Packed)
	1.3M	84fps(8bit), 42fps(10bit), 56fps(10bit Packed), 42fps (12bit), 56fps(12bit Packed)
Image format	Mono8 / Mono10 / Mono10Packed / Mono12 /Mono12Packed	
Capable bandwidth	400 nm ~ 1,700nm	
Electronic shutter	8μ sec ~ 16.777 sec	
Analog gain	0 ~ 14.8 dB	
Digital gain	x1 ~ x3	
ROI	0.3M	Horizontal : 8~640pixel/Vertical : 8~512Line image size adjust unit : H 8pixel/ V 8Line image offset adjustment valley : H 8pixel/ V 8Line
	1.3M	Horizontal : 8~1,280pixel/Vertical : 8~1,024Line image size adjust unit : H 8pixel/ V 8Line image offset adjustment valley : H 8pixel/ V 8Line
Gamma	Gamma 0.1~4.0	
Binning	x2 Horizontal • Vertical / Off	
Decimation	x2 Horizontal • Vertical / Off	
Image Flip	Top bottom / right left / top bottom right left / off	
Pixel defect correction	Maximum 8,192 pixels	
Automatic image quality control	Automatic exposure : corresponded Auto Gain : corresponded Auto white balance : N/A	
Operating mode	Edge preset / pulse trigger / free run (continuous mode)	
Interface	PoE : IEEE802.3af CLASS3 (1000BASE-T)	
Protocol	GigE Vision 2.1 GenICam SFNC 2.6 base IEEE1588(PTP)corresponded	
Input/output terminal	1Input (opt isolated) / 1output (opt isolated) 1In/output (non-isolated, open collector)	
Power input voltage	+10.8 ~ 26.4Vdc(power signal connector) Power Over Ethernet (IEEE802.3afbase)	
Power consumption	+12V / +24V : 10.1 W, PoE : 10.2W	
Lens mount	C mount	
Weight	around 465g	
Operating temperature (low limit)	Ambient environment temperature : 0°C, Ambient environment humidity : 20~85%RH (no condensation)	
Operating temperature (high limit)	Ambient environment temperature : +56°C, Ambient environment humidity : 20~85%RH (no condensation) ,boundary temperature : +68°C	

Spectral characteristic table

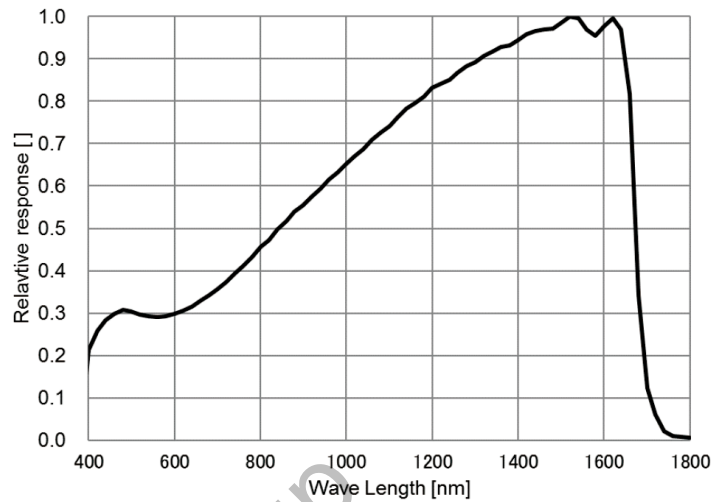

Drawing

