

## CEI Machine Vision Camera Enclosure IP67 88mm Series Round

As a leading innovator in the Machine Vision Industry, CEI is proud to introduce our new line of Machine Vision Camera Enclosures, Cables, and Accessories for demanding vision applications.

### IP67 88mm Series Camera Round Enclosure Key Features

- CEI Integrated Connector Design ( no cord grips )
- IP67 protection
- Universal design for camera models with up to 60mm<sup>2</sup> body
- Also supports Dalsa Genie Nano XL, Nano 5G, Sony Block
- Excellent heat dissipation
- Enclosure tailored for specific Camera & Optics
- Adjustable Mount with 4 tapped holes included
- High quality (easy to replace) windows by Midwest Optical
- Lightweight low-profile design
- Type 2 anodizing
- Options: Mounts, Windows & Filters, Cables
- Options: Custom Sizes, lengths, and focusing solutions.
- Options: Complete Solutions (Camera, Enclosure, Cabling)
- Competitive pricing
- Made in USA, Patent Pending

### Enclosure Specs (See Appendix "A" for part numbers)

Camera Size: up to 60mm square machine vision

Optics: Supports a wide range optics

Window: Midwest Optical 2mm- AR coated  
Borofloat glass

Lens Covers: Available in 79mm and 103mm Diameters  
Lengths in 10mm increments

Interface Connectors: M12 X-Code Ethernet Female

Optional Interface: M12 A-Code I/O Male

Mounting: Qty. 2, M6 and Qty. 2 ¼-20 UNC tapped holes with  
19.05mm (¾") hole spacing  
Adjustable ring mount

Sealing: IP67

Material: 6061 Aluminum

Coating: Type 2 anodized

Overall Length (L): Varies, See Appendix "A"

Body Length (B): Varies, See Appendix "A"

Height / Width (D): 95 mm OD round (body)

Mount diameter: 120 mm

Weight: ~1000g (typical weight fully assembled  
W/ Camera)

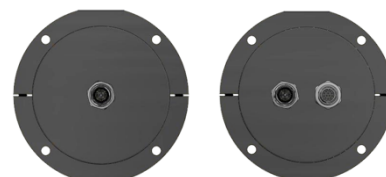
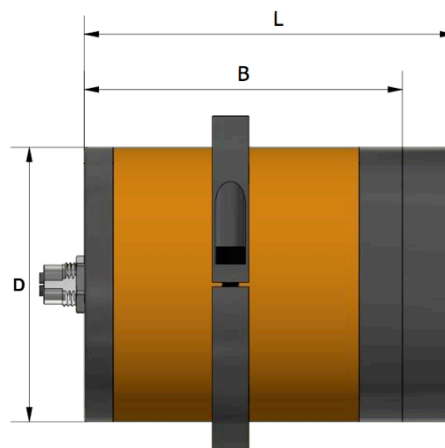

## Appendix "A" CEI IP67 88mm Series Camera Round Enclosure Part Numbers:

PART NUMBER	ENCLOSURE BODY, END CAP, AND ROUND MOUNT
EN-88R-A0-95	88mm x 95mm long enclosure, M12 x-code, no I/O, Fits up to 62mm x 62mm cameras
EN-88R-A1-95	88mm x 95mm long enclosure, M12 x-code, with Nano I/O, Fits up to 62mm x 62mm cameras
EN-88R-B1-160	88mm x 160mm long enclosure, M12 x-code, with M12 8 pin I/O, Fits FCB-8550/8530

PART NUMBER	FRONT BEZEL DIAMETER TO MATCH LENS CAP
EN-88R-FB79-A	Front bezel for 88mm round enclosure, for 79mm lens diameter caps, Type A style cameras
EN-88R-FB103-A	Front bezel for 88mm round enclosure, for 103mm diameter lens caps, Type A style cameras
EN-88R-FB79-B	Front bezel for 88mm round enclosure, Fits FCB-8550/8530 (no lens cover required)
EN-88R-FB79-C	Front bezel for 88mm round enclosure, for 79mm lens diameter caps, Type C style cameras

PART NUMBER	LENS CAPS ONLY 79MM DIAMETER - ENCLOSURE AND FRONT BEZEL REQUIRED
EN-LC79-70	Lens cover for 79mm bezel, 70mm length, borosilicate window
EN-LC79-80	Lens cover for 79mm bezel, 80mm length, borosilicate window

PART NUMBER	LENS CAPS ONLY 103MM DIAMETER - ENCLOSURE AND FRONT BEZEL REQUIRED
EN-LC103-90	Lens cover for 103mm bezel, 90mm length, borosilicate window

PART NUMBER	Accessories
EN-88R-SSB	Sun Shade with Bird Spikes