

CEI Machine Vision Camera Enclosure IP67 55mm Series Round

As a leading innovator in the Machine Vision Industry, CEI is proud to introduce our new line of Machine Vision Camera Enclosures, Cables, and Accessories for demanding vision applications.

IP67 55mm Series Camera Round Enclosure Key Features

- CEI Integrated Connector Design (no cord grips)
- IP67 protection
- Universal design for camera models with up to 42mm² body
- Also supports many popular Dalsa Genie Nano cameras
- Excellent heat dissipation
- Enclosure tailored for specific Camera & Optics
- Adjustable Mount with 4 tapped holes included
- High quality (easy to replace) windows by Midwest Optical
- Lightweight low-profile design
- Type 2 anodizing
- Options: Mounts, Windows & Filters, Cables
- Options: Custom Sizes, lengths, and focusing solutions.
- Options: Complete Solutions (Camera, Enclosure, Cabling)
- Competitive pricing
- Made in USA, Patent Pending

Enclosure Specs (See Appendix "A" for part numbers)

Camera Size: up to 42mm square or 44mm x 29mm machine vision

Optics: Supports a wide range optics

Window: Midwest Optical 2mm- AR coated
Borofloat glass or Acrylic

Lens Covers: Available in 55mm and 60mm Diameters
Lengths in 10mm increments

Interface Connectors: M12 X-Code Ethernet Female

Optional Interface: M12 A-Code I/O Male, HDMI, HD-BNC

Mounting: Qty. 2, M6 and Qty. 2 ¼-20 UNC tapped holes with
19.05mm (¾") hole spacing
Adjustable ring mount

Sealing: IP67

Material: 6061 Aluminum

Coating: Type 2 anodized

Overall Length (L): Varies, See Appendix "A"

Body Length (B): Varies, See Appendix "A"

Height / Width (C): 63.5 mm OD round (body)

Mount diameter: 88.9 mm

Window Diameter: 62 mm

Weight: ~500g (typical weight fully assembled
W/ Camera)

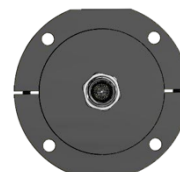
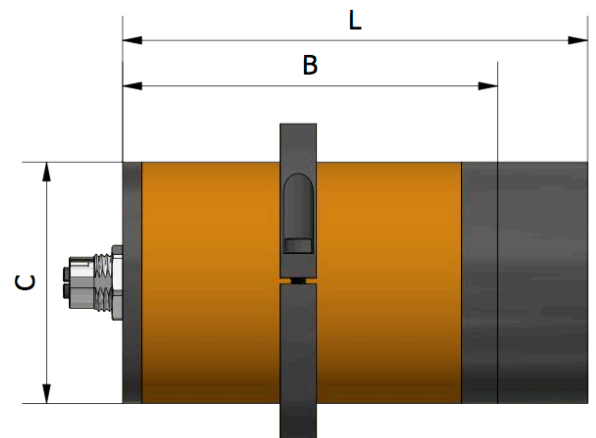

Appendix “A” CEI IP67 55mm Series Camera Round Enclosure Part Numbers:

PART NUMBER	ENCLOSURE BODY, END CAP, AND ROUND MOUNT
EN-55R-A0-90	55mm x 90mm long enclosure, M12 x-code, no I/O, Fits up to 42mm x 42mm cameras
EN-55R-A1-90	55mm x 90mm long enclosure, M12 x-code, with M12 8p male I/O, Fits up to 42mm x 42mm cameras
EN-55R-B0-90	55mm x 90mm long enclosure, HDMI, no I/O, Fits up to 42mm x 42mm cameras
EN-55R-B1-90	55mm x 90mm long enclosure, HDMI, with I/O, Fits up to 42mm x 42mm cameras
EN-55R-C0-90	55mm x 90mm long enclosure, HD-BNC, no I/O, Fits up to 42mm x 42mm cameras
EN-55R-C1-90	55mm x 90mm long enclosure, HD-BNC, M12 12p male I/O, Fits up to 42mm x 42mm cameras
EN-55R-D1-90	55mm x 90mm long enclosure, M12 x-code, with I/O for Nano. Fits up to 42mm x 42mm cameras
EN-55R-E1-110	55mm x 110 long enclosure, M12 x-code, with M12 8p male I/O for MicroScan MicroHawk MV-40
EN-55R-F1-110	55mm x 110 long enclosure, M12 x-code, with M12 12p male I/O for Basler Scout sca640-70gm
EN-55R-G1-110	55mm x 110mm long enclosure, HD-BNC, M12 12p male I/O, Fits CIS Clairvu 3G SDI HD3 Camera
PART NUMBER	FRONT BEZEL DIAMETER TO MATCH LENS CAP
EN-55R-FB55-A	Front bezel for 55mm round enclosure, for 55mm lens diameter caps, Type A style cameras
EN-55R-FB55-B	Front bezel for 55mm round enclosure, for 55mm diameter lens caps, Type B style cameras
EN-55R-FB55-C	Front Bezel for 55mm round enclosure, for 55mm diameter lens caps, Type C style cameras
EN-55R-FB55-D	Front Bezel for 55mm round enclosure, no lens cap required, type D style cameras
EN-55R-FB55-E	Front Bezel for 55mm round enclosure, for 55mm diameter lens caps, Type E style cameras
EN-55R-FB60-C	Front Bezel for 55 mm round enclosure, for 60mm diameter lens caps, Type C style cameras
EN-55R-FB55-F	Front Bezel for 55mm round enclosure, for 55mm diameter lens caps, Type F style cameras
EN-55R-FB55-G	Front Bezel for 55mm round enclosure, for 55mm diameter lens caps, Type G style cameras
PART NUMBER	LENS CAP ONLY 55MM DIAMETER W/ BOROSILICATE GLASS WINDOW - ENCLOSURE AND FRONT BEZEL REQUIRED
EN-LC55-30	Lens cover for 55mm bezel, 30mm length, borosilicate window
EN-LC55-40	Lens cover for 55mm bezel, 40mm length, borosilicate window
EN-LC55-50	Lens cover for 55mm bezel, 50mm length, borosilicate window
EN-LC55-60	Lens cover for 55mm bezel, 60mm length, borosilicate window
EN-LC55-70	Lens cover for 55mm bezel, 70mm length, borosilicate window
EN-LC55-80	Lens cover for 55mm bezel, 80mm length, borosilicate window

Appendix “A” CEI IP67 55mm Series Camera Round Enclosure Part Numbers (Continued):

PART NUMBER	LENS CAP ONLY 55MM DIAMETER W/ ACRYLIC WINDOW - ENCLOSURE AND FRONT BEZEL REQUIRED
EN-LC55-30A	Lens cover for 55mm bezel, 30mm length, acrylic window
EN-LC55-40A	Lens cover for 55mm bezel, 40mm length, acrylic window
EN-LC55-50A	Lens cover for 55mm bezel, 50mm length, acrylic window
EN-LC55-60A	Lens cover for 55mm bezel, 60mm length, acrylic window
EN-LC55-70A	Lens cover for 55mm bezel, 70mm length, acrylic window
EN-LC55-80A	Lens cover for 55mm bezel, 80mm length, acrylic window
EN-LC55-150A	Lens cover for 55mm bezel, 150mm length, acrylic window
PART NUMBER	LENS CAP ONLY 60MM DIAMETER - ENCLOSURE AND FRONT BEZEL REQUIRED
EN-LC60-30	Lens cover for 60mm bezel, 30mm length, borosilicate window
EN-LC60-40	Lens cover for 60mm bezel, 40mm length, borosilicate window
EN-LC60-50	Lens cover for 60mm bezel, 50mm length, borosilicate window
EN-LC60-60	Lens cover for 60mm bezel, 60mm length, borosilicate window
EN-LC60-70	Lens cover for 60mm bezel, 70mm length, borosilicate window
EN-LC60-80	Lens cover for 60mm bezel, 80mm length, borosilicate window
EN-LC60-90	Lens cover for 60mm bezel, 90mm length, borosilicate window
PART NUMBER	CUSTOM MOUNTS
EN-M4	4 AXIS MOUNT
PART NUMBER	Accessories
EN-N	Nitrogen Charge

