

EL3Z0416UCS-MPWIR

3X 4.0mm -10mm F1.6 Day & Night
for 1/1.8 type 5M Cameras, Motorized Control Vari-focal
USB interface, CS-Mount

Optical Specifications

Model No.		EL3Z0416UCS-MPWIR		Min. Objective Distance		0.2m from front of lens	
Focal Length		4.0mm - 10mm		Effective Lens Aperture		Front:φ25mm Rear:φ10mm	
F-Number	Wide	F1.6 - F16C		Back Focal Length	Wide	8.5 mm (in Air)	
	Tele	F2.7 - F16C			Tele	8.5 mm (in Air)	
Max. Image Format		7.1mm x 5.4mm (φ8.9mm)		Flange Back Length		12.5mm (In Air)	
Angle of View	Diagonal	1/1.8 type	138.1°~ 52.9°	1/1.8 type (4:3)	138.1°~ 52.9°	1/2.7 type (16:9)	96.1°~ 39.1°
	Horizontal	(16:9)	115.9°~ 46.0°		104.8°~ 42.2°		82.6°~ 34.1°
	Vertical		61.7°~ 25.8°		76.3°~ 31.6°		45.3°~ 19.1°
	Diagonal	1/2.8 type	92.9°~ 37.9°	1/3 type (4:3)	86.5°~ 35.5°		
	Horizontal	(16:9)	79.9°~ 33.0°		68.1°~ 28.4°		
	Vertical		43.9°~ 18.5°		50.5°~ 21.3°		

Mechanical & Electrical Specifications

Control Interface		USB2.0	Dimensions	As per the attached drawing
Power mode		Bus power (500mA)	Mount	CS mount
Connector		USB TypeA	Weight	161g
Operating Temperature		-20°C - +60°C	Tripod Screw	-
Control	Iris	Motorized	Filter thread	*M55 x P0.75 (With VM0418)
	Focus	Motorized		
	Zoom	Motorized		

(*Adapting for between 6mm and 10mm.

(*For using filters, please attach VM0418 (Sold Separately)

Dimensions

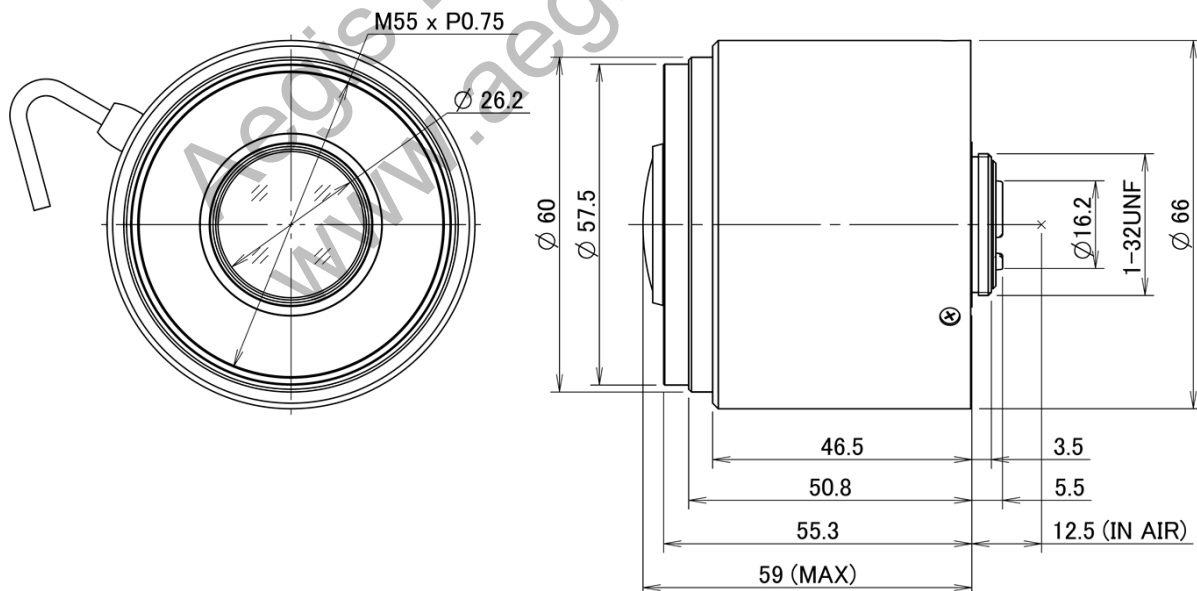

Length of Wire

300±20 (mm)

This specification is subject to change without any notice.

2021.12